

REVISIONS

P	LTR	DESCRIPTION	DATE	DWN	APVD
A1		REVISED	30JUL2013		
A2		ECR-14-008826	13JUL2014	HW	XX
A3		ECR-16-006227	28APR2016	FY	XX
A4		ECR-19-009366	13JUN2019	HH	CW

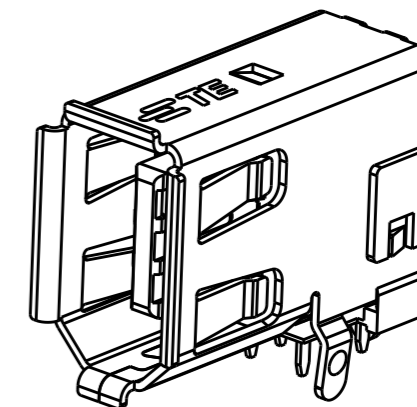
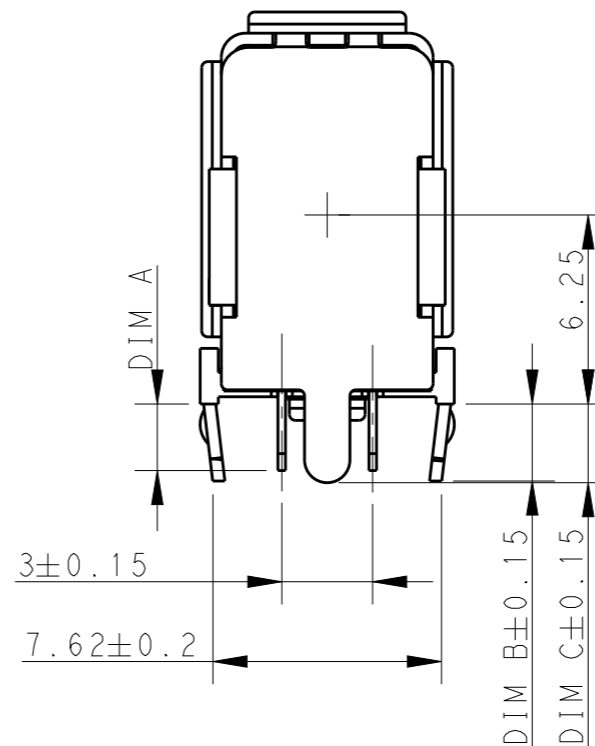
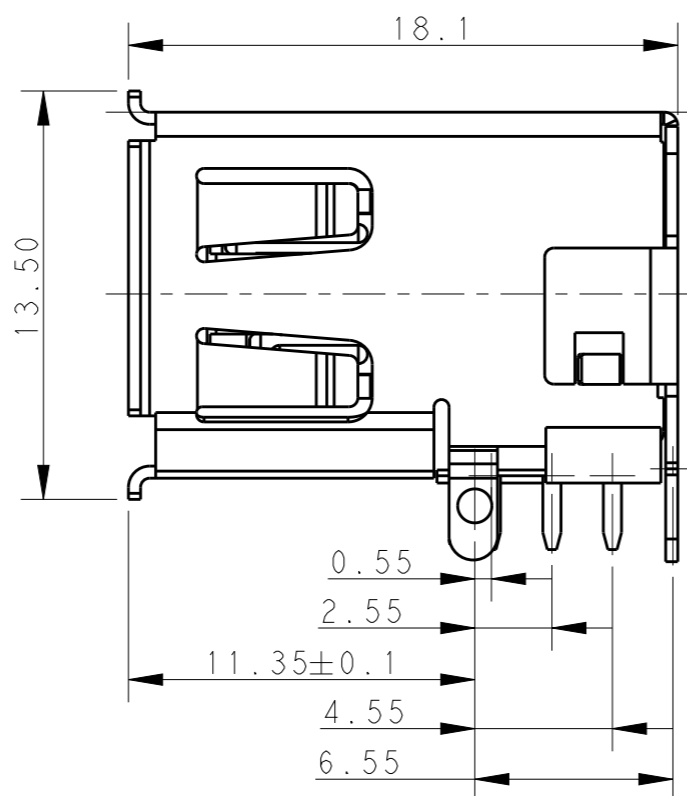
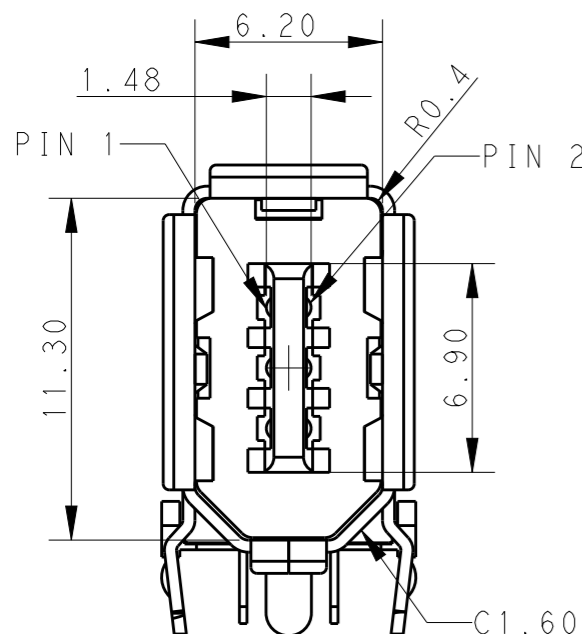
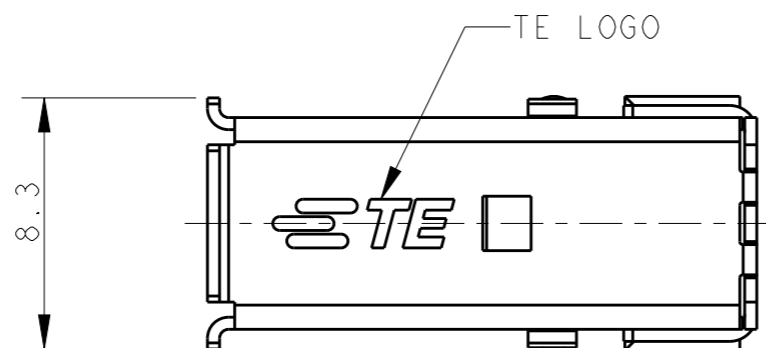

NOTE:

- MATERIAL:
HOUSING: PBT WITH 30% GF, BLACK COLOR
CONTACTS: BRASS
SHELL: PHOSPHOR BRONZE
- FINISH:
CONTACTS: 0.75µm(30u") MIN. GOLD PLATED ON CONTACT AREA
2.54µm(100u") MIN. MATTE-TIN ON SOLDER TAIL, WITH ENTIRE CONTACT UNDERPLATED
1.27µm(50u") MIN. NICKEL PLATED
SHELL: 1.27µm(50u") MIN. BRIGHT-TIN PLATED OVER
1.27µm(50u") MIN. NICKEL PLATED
- WAVE SOLDER CAPABLE TO 265°C PER TE TEST SPEC. 109-202, CONDITION B

2232261-2	2.20	2.60	2.60	108-106127
2232261-1	3.20	3.59	3.70	
PART NUMBER	DIM A	DIM B	DIM C	PRORUCT SPEC

THIS DRAWING IS A CONTROLLED DOCUMENT.

DIMENSIONS:
mm

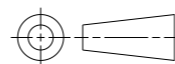

TOLERANCES UNLESS OTHERWISE SPECIFIED:

0 PLC	±-
1 PLC	±0.3
2 PLC	±0.2
3 PLC	±-
4 PLC	±-
ANGLES	±-

MATERIAL

SEE NOTE

FINISH

SEE NOTE

DWN 28APR2016

FENCER YU

CHK 28APR2016

KOBBY ZHAO

APVD 28APR2016

XIANG XU

PRODUCT SPEC

SEE TABLE

APPLICATION SPEC

-

WEIGHT

3.17 g

CUSTOMER DRAWING



TE Connectivity

NAME
1394_A RECEPTACLE UP RIGHT R/A THRU HOLE TYPE

SIZE CAGE CODE DRAWING NO RESTRICTED TO

A3 00779 C-2232261

SCALE 4:1 SHEET 1 OF 6 REV A4

4

3

2

1

THIS DRAWING IS UNPUBLISHED.

RELEASED FOR PUBLICATION

20

© COPYRIGHT 20 BY -

ALL RIGHTS RESERVED.

REVISIONS

P	LTR	DESCRIPTION	DATE	DWN	APVD
-	-	SEE SHEET 1	-	-	-

VIEW F

100pcs/Troy

315±1.0

230±1.0

NOTE:

1. PACKAGING MATERIAL IN PLASTIC, RUBBER, INK, PIGMENT AND PAINT MUST MEET CONTROLLED SUBSTANCES SPEC PER 230-702

1) CADMIUM AND CADMIUM COMPOUNDS NOT TO EXCEED: 5PPM

2) LEAD, CADMIUM, CHROM VI AND MERCURY NOT EXCEED: 100PPM (COMBINED)

28.7

20

VIEW F

THIS DRAWING IS A CONTROLLED DOCUMENT.

DWN 28APR2016

FENCER YU

CHK 28APR2016

KOBBY ZHAO

APVD 28APR2016

XIANG XU

PRODUCT SPEC

SEE TABLE

APPLICATION SPEC

-

WEIGHT

3.17 g

CUSTOMER DRAWING

TE Connectivity

NAME 1394_A RECEPTACLE UP RIGHT R/A THRU HOLE TYPE

SIZE	CAGE CODE	DRAWING NO	RESTRICTED TO
A3	00779	C-2232261	

A3 00779 C-2232261

SCALE 4:1

SHEET 2 OF 6

REV A4

DIMENSIONS:

mm

TOLERANCES UNLESS OTHERWISE SPECIFIED:

0 PLC	±0.3
1 PLC	±0.3
2 PLC	±0.2
3 PLC	±0.2
4 PLC	±0.2
ANGLES	±0.5

MATERIAL

SEE NOTE

FINISH

SEE NOTE

1470-19 (3/13)

Downloaded From Onevac.com

THIS DRAWING IS UNPUBLISHED.

RELEASED FOR PUBLICATION

20

© COPYRIGHT 20 BY -

ALL RIGHTS RESERVED.

REVISIONS

P	LTR	DESCRIPTION	DATE	DWN	APVD
-	-	SEE SHEET 1	-	-	-

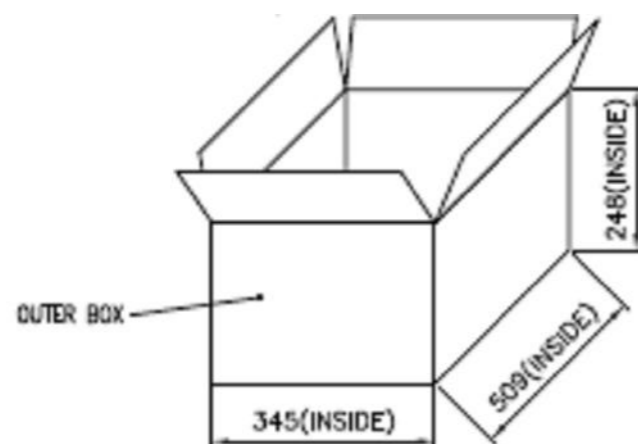
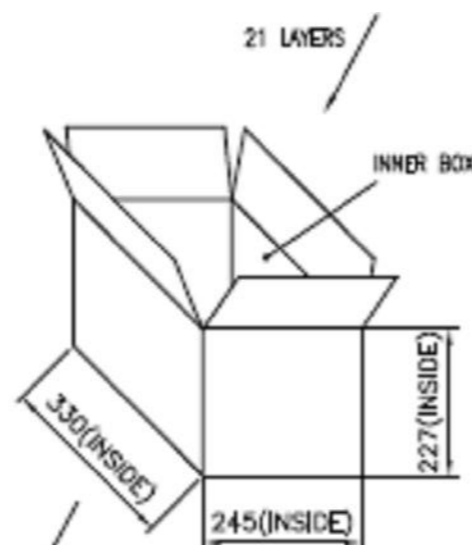
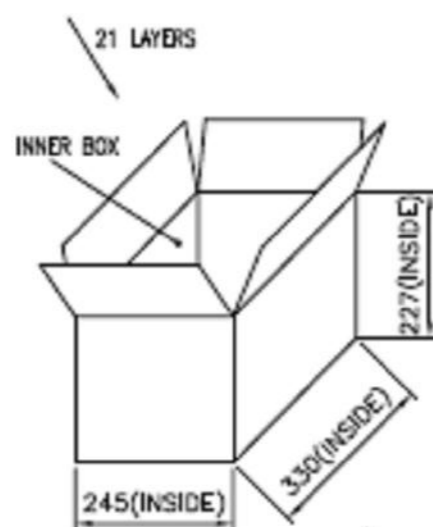
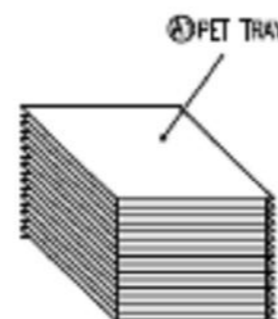
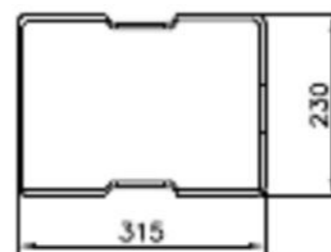
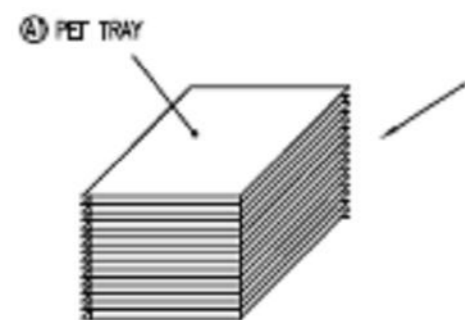

2232261-2	17.42Kg	13.32Kg	100	21	42	4200PCS
2232261-1	17.75Kg	13.65Kg	100	21	42	4200PCS
PART NUMBER	GROSS WEIGHT	NET WEIGHT	PCS/TRAY	TRAYS/ INNER BOX	TRATS /CARTON	QUANTITY

THIS DRAWING IS A CONTROLLED DOCUMENT.

DIMENSIONS: mm

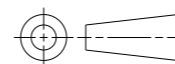

TOLERANCES UNLESS OTHERWISE SPECIFIED:

0 PLC	±-
1 PLC	±0.3
2 PLC	±0.2
3 PLC	±-
4 PLC	±-
ANGLES	±-

MATERIAL: SEE NOTE

FINISH: SEE NOTE

DWN 28APR2016
FENCER YU
CHK 28APR2016
KOBBY ZHAO
APVD 28APR2016
XIANG XU

PRODUCT SPEC: SEE TABLE
APPLICATION SPEC: -
WEIGHT: 3.17 g
CUSTOMER DRAWING



NAME: 1394_A RECEPTACLE UP RIGHT R/A THRU HOLE TYPE

SIZE: A3 CAGE CODE: 00779 DRAWING NO: C-2232261 RESTRICTED TO:

SCALE: 4:1 SHEET: 3 OF 6 REV: A4

P	LTR	DESCRIPTION	DATE	DWN	APVD
-	-	SEE SHEET 1	-	-	-

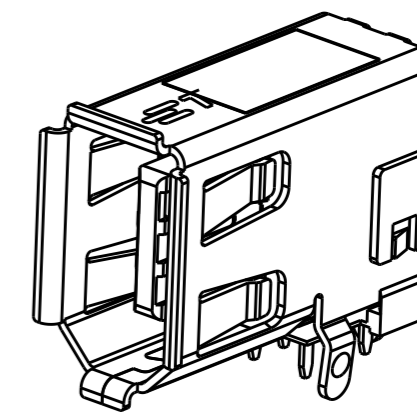
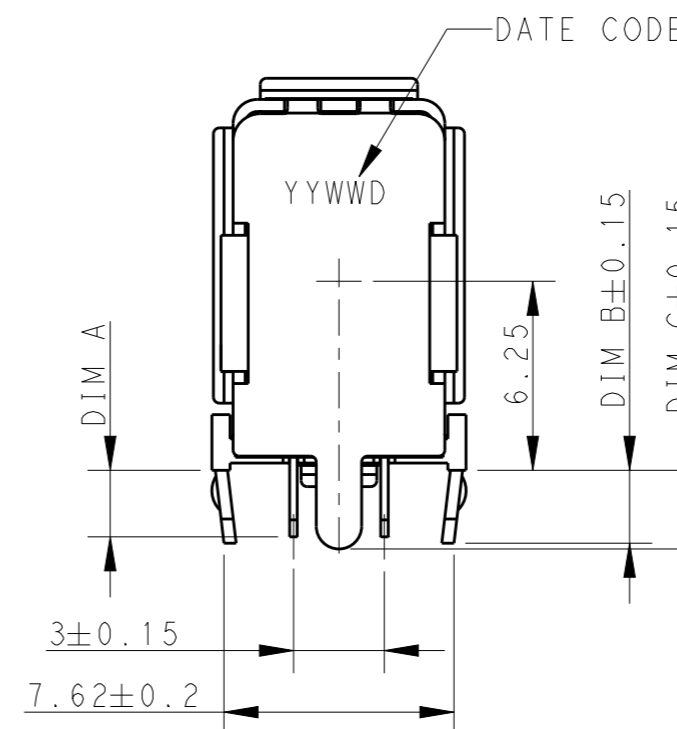
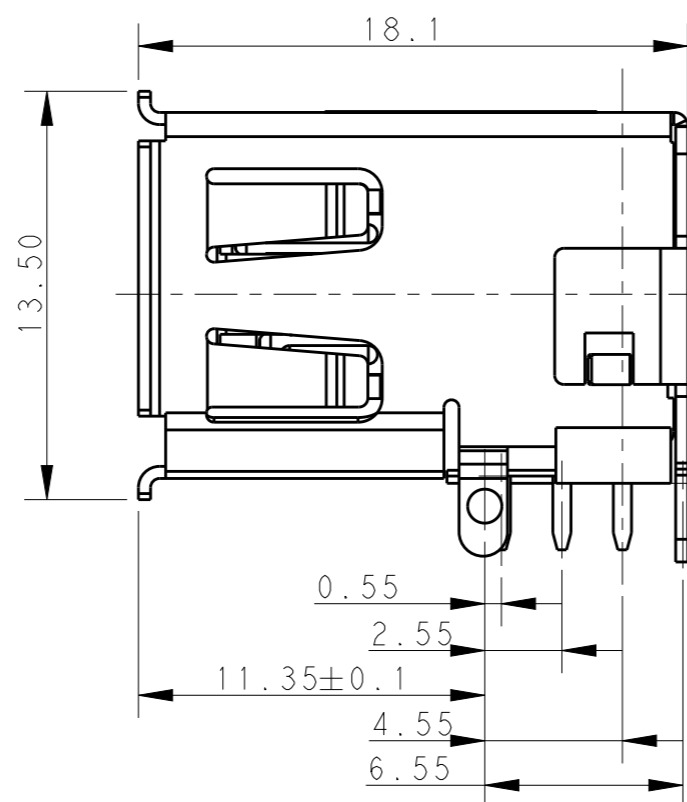
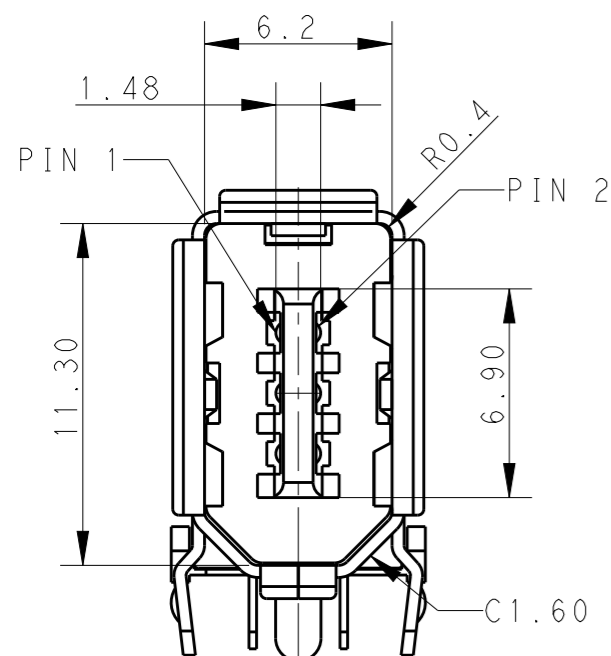
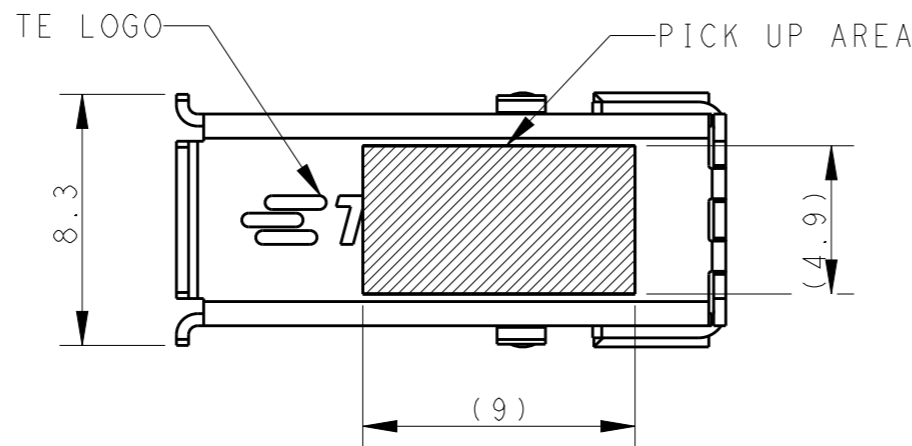

NOTE:

- MATERIAL:
HOUSING: PA9T WITH 33% GF, BLACK COLOR
CONTACTS: BRASS
SHELL: PHOSPHOR BRONZE
MYLAR
- FINISH:
CONTACTS: 0.75µm(30u") MIN. GOLD PLATED ON CONTACT AREA
2.54µm(100u") MIN. MATTE-TIN ON SOLDER TAIL,
WITH ENTIRE CONTACT UNDERPLATED
1.27µm(50u") MIN. NICKEL PLATED
SHELL: 1.27µm(50u") MIN. MATTE TIN PLATED OVER
1.27µm(50u") MIN. NICKEL PLATED
- REFLOW SOLDER CAPABLE TO 260°C MAX PER TE TEST SPEC.
- DATE CODE: YYWWD (YY: YEAR WW: WEEK D: DAY)

A4	2232261-3	2.20	2.60	2.60	108-137412
	PART NUMBER	DIM A	DIM B	DIM C	PRODUCT SPEC

THIS DRAWING IS A CONTROLLED DOCUMENT.		DWN 28APR2016 FENCER YU	TE Connectivity		
DIMENSIONS: mm		CHK 28APR2016 KOBBY ZHAO			
TOLERANCES UNLESS OTHERWISE SPECIFIED:		APVD 28APR2016 XIANG XU	NAME 1394_A RECEPTACLE UP RIGHT R/A THRU HOLE TYPE		
0 PLC ±-		PRODUCT SPEC	-		
1 PLC ±0.3		APPLICATION SPEC	-		
2 PLC ±0.2		WEIGHT	SIZE	CAGE CODE	DRAWING NO
3 PLC ±-		3.17 g	A3	00779	C-2232261
4 PLC ±-		CUSTOMER DRAWING	SCALE	SHEET	REV
ANGLES ±-			4:1	4 OF 6	A4
FINISH					
SEE NOTE					

THIS DRAWING IS UNPUBLISHED. RELEASED FOR PUBLICATION 20
 © COPYRIGHT 20 BY - ALL RIGHTS RESERVED.

REVISIONS

P	LTR	DESCRIPTION	DATE	DWN	APVD
-	-	SEE SHEET 1	-	-	-

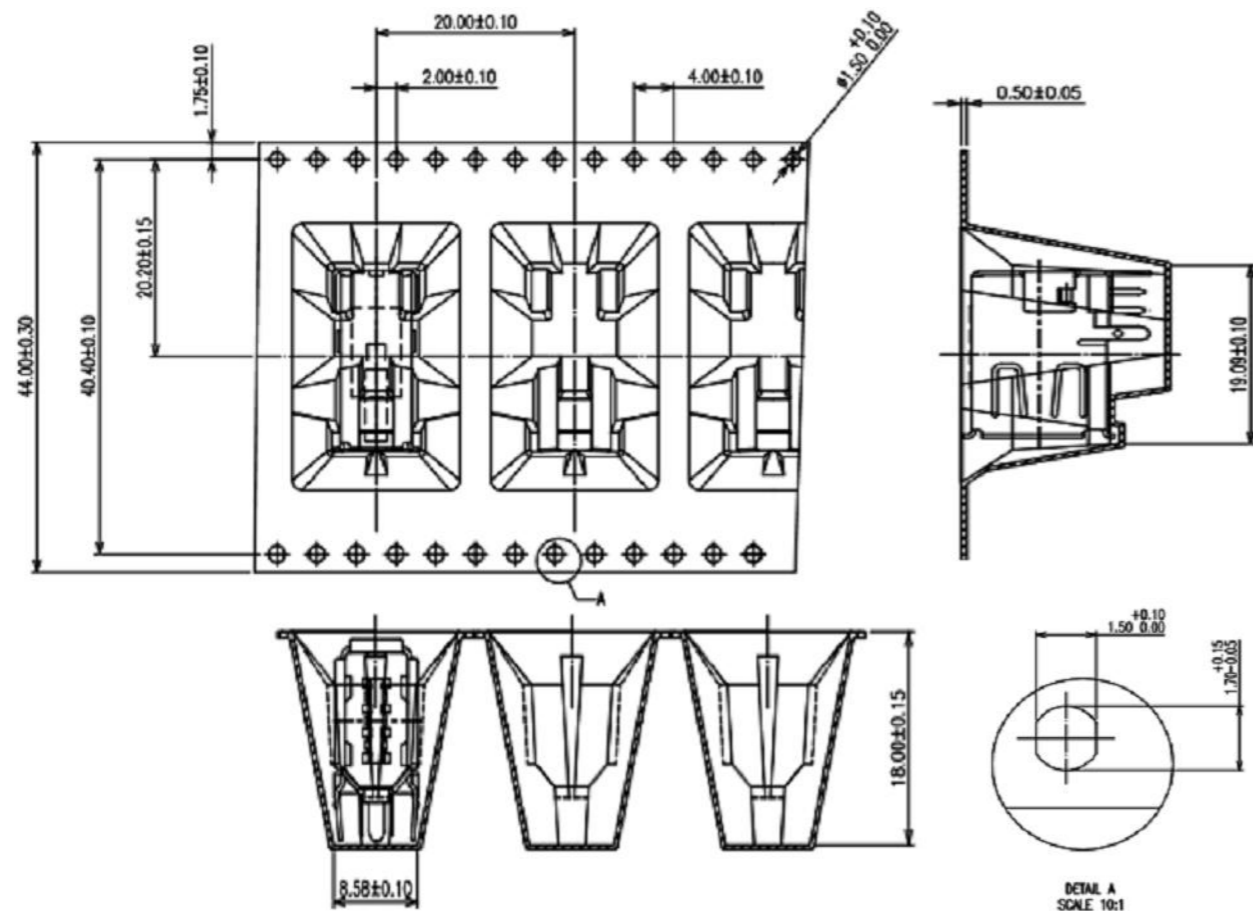

- NOTE:
1. USED ON 1394 SERIES
 2. PACKAGE 150PCS/REEL, 900PCS/BOX
 3. MATERIAL: BLACK CONDUCTIVE POLYSTYRENE
 4. APPLICABLE DOCUMENT: EIA-481-D
 5. BEFORE UNREELING DIRECTION MUST HAVE 20PCS BLANK (400MM MIN)
 6. AFTER UNREELING DIRECTION MUST HAVE 9PCS BLANK (170MM MIN)

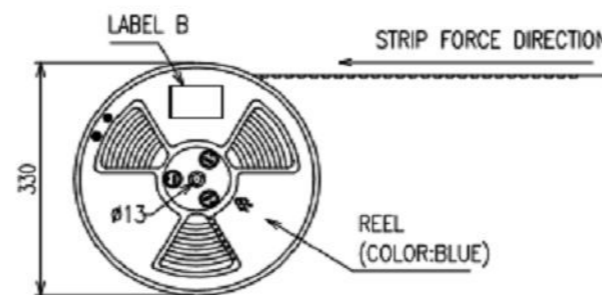
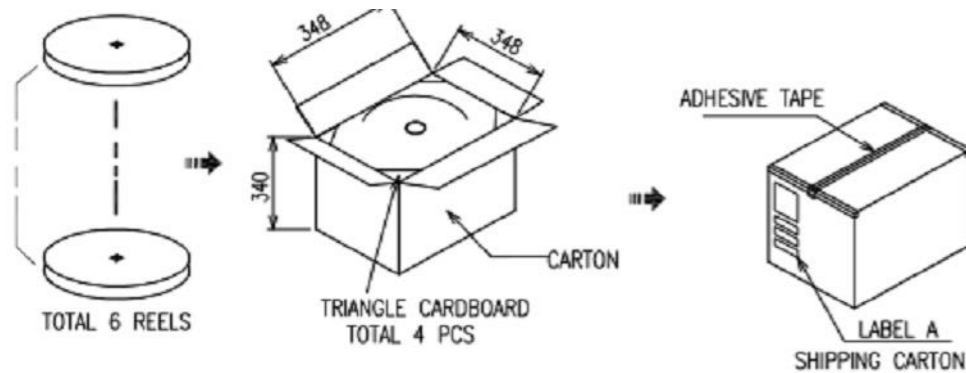
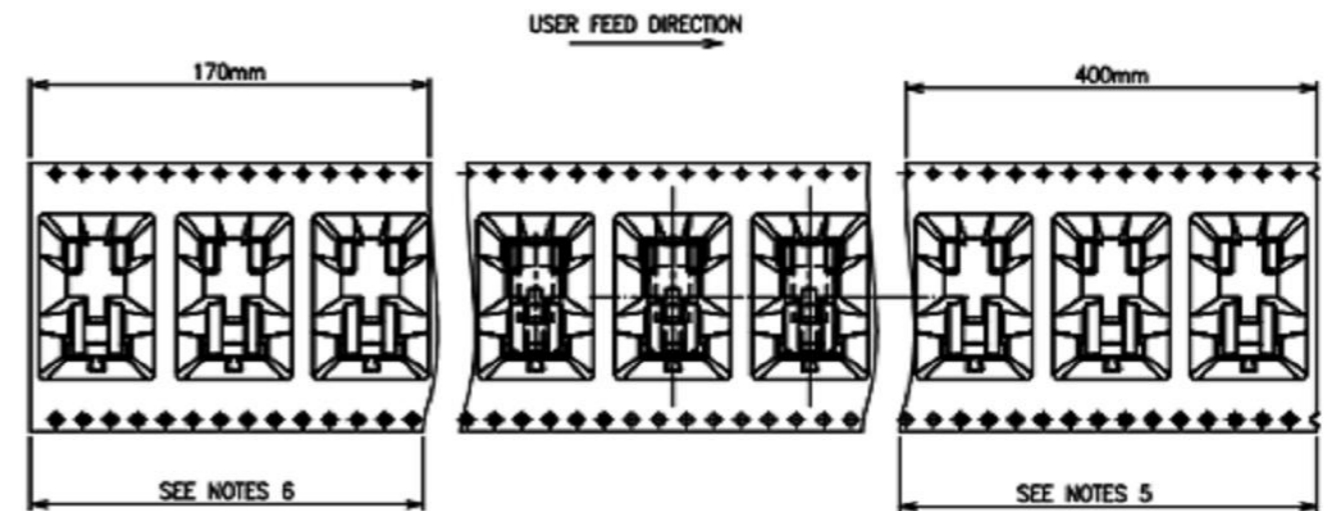

Part number: 2232261-3
 Quantity: 150
 Date code: ****
 Rev: *
 Country of origin: China
 2232261-3

LABEL DETAIL B

Part number: 2232261-3
 Quantity: 900
 Date code: ****
 Rev: *
 Country of origin: China
 2232261-3

LABEL DETAIL A

A4

PART NUMBER	GROSS WEIGHT	NET WEIGHT	PCS/REEL	REEL/ INNER BOX	QUANTITY
2232261-3	4.51Kg	2.92Kg	150	6	900PCS

THIS DRAWING IS A CONTROLLED DOCUMENT.		DWN 28APR2016 FENCER YU	TE Connectivity	
DIMENSIONS: mm		CHK 28APR2016 KOBBY ZHAO		
TOLERANCES UNLESS OTHERWISE SPECIFIED:		APVD 28APR2016 XIANG XU	NAME 1394_A RECEPTACLE UP RIGHT R/A THRU HOLE TYPE	
0 PLC ± 1 PLC ±0.3 2 PLC ±0.2 3 PLC ± 4 PLC ±		PRODUCT SPEC SEE TABLE	SIZE CAGE CODE DRAWING NO RESTRICTED TO	
MATERIAL SEE NOTE		FINISH SEE NOTE	A300779 C-2232261	
SEE NOTE		WEIGHT 3.17 g	SCALE 4:1 SHEET 5 OF 6 REV A4	
SEE NOTE		CUSTOMER DRAWING		

THIS DRAWING IS UNPUBLISHED.

RELEASED FOR PUBLICATION

20

© COPYRIGHT 20 BY -

ALL RIGHTS RESERVED.

REVISIONS

P	LTR	DESCRIPTION	DATE	DWN	APVD
-	-	SEE SHEET 1	-	-	-

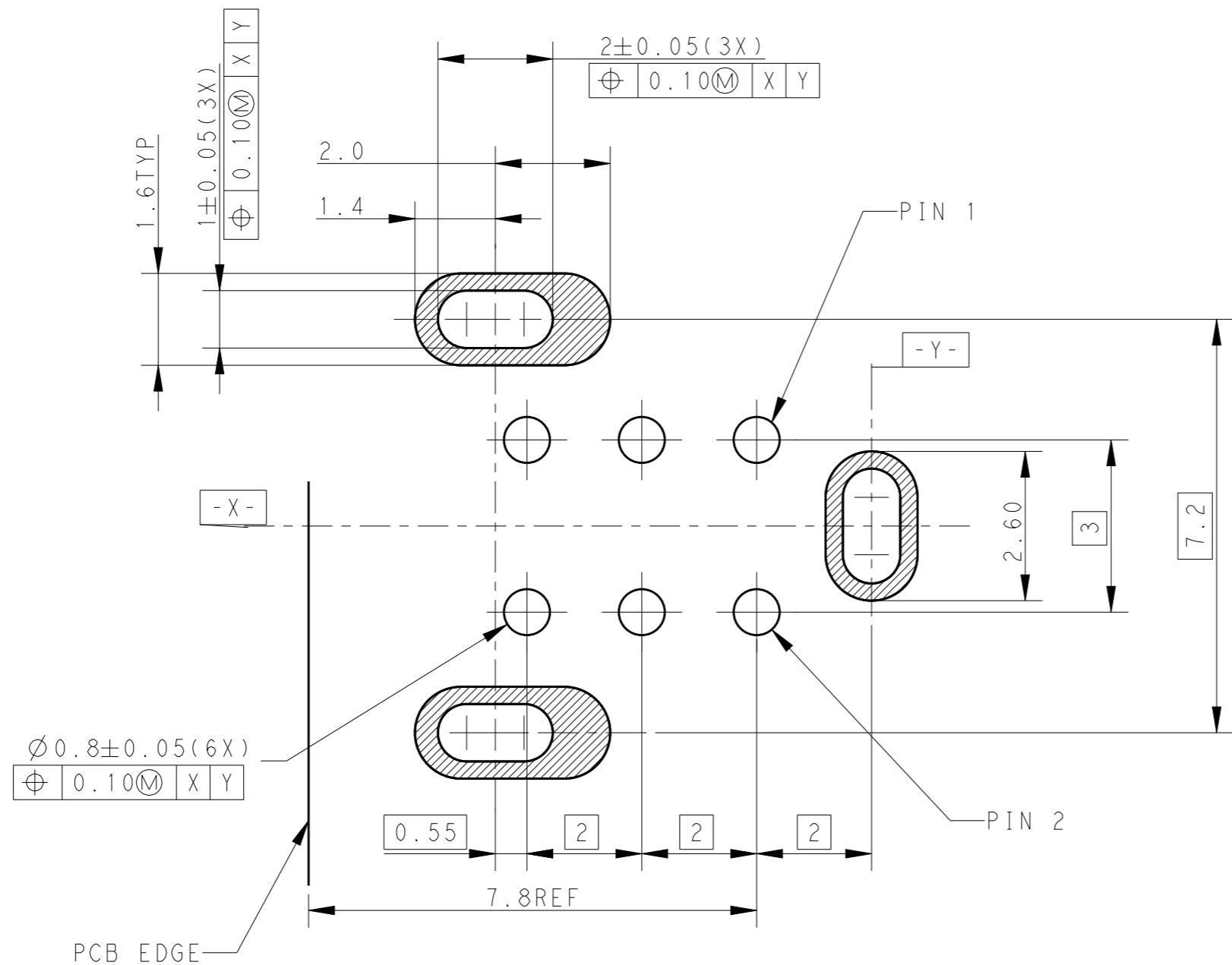

RECOMMENDED PCB LAYOUT

THIS DRAWING IS A CONTROLLED DOCUMENT.		DWN FENCER YU 28APR2016	 TE Connectivity	
DIMENSIONS: mm		CHK KOBBY ZHAO 28APR2016		
TOLERANCES UNLESS OTHERWISE SPECIFIED		APVD XIANG XU 28APR2016	NAME 1394_A RECEPTACLE UP RIGHT R/A THRU HOLE TYPE	
0 PLC ± 1 PLC ±0.3 2 PLC ±0.2 3 PLC ± 4 PLC ± ANGLES ±		PRODUCT SPEC SEE TABLE	RESTRICTED TO	
MATERIAL SEE NOTE		APPLICATION SPEC -	SIZE A3	CAGE CODE 00779
FINISH SEE NOTE		WEIGHT 3.17 g	DRAWING NO C-2232261	SCALE 4:1
		CUSTOMER DRAWING	SHEET 6 OF 6	REV A4

单击下面可查看定价，库存，交付和生命周期等信息

[>>TE Connectivity\(泰科\)](#)