

THIS DRAWING IS UNPUBLISHED.

RELEASED FOR PUBLICATION

© COPYRIGHT - TE Connectivity Ltd.

ALL RIGHTS RESERVED.

REVISIONS

P	LTR	DESCRIPTION	DATE	DWN	APVD
	A	INITIAL DRAWING	26AUG2019	VM	MP

Ordering Information

Sample Part Number ▶

PD350 X B 5 7

Series: _____

Contact Form: _____

X = SPST-NO, Double Make

Coil Voltage: _____

A = 12 Vdc, Stud Terminals

B = 24 Vdc, Stud Terminals

Power Terminals: _____

5 = Stud Terminals

Mounting: _____

7 = Panel Mount, Captive Bolts

Coil Data

Volts, Nominal	12 V	24 V
Pickup, Max. @ 65°C	9.9 Vdc	19.7 Vdc
Hold, Max. @ 65°C	8.5 Vdc	17 Vdc
Dropout, Min. @ -35°C	1.2 Vdc	2.4 Vdc
Coil Power** 25°C		
During Pickup (300 ms)	43 W	43 W
While Holding	8 W	8 W
Energy, Magnetic, Max.***	.26 J	.26 J

**Two coils are employed for power economizing subsequent to pickup. During pickup both coils operate in parallel drawing 43 Watts momentarily. After pickup, the electronic economizing system leaves only the holding coil on, drawing 8 Watts @ 25°C. Economizing system includes transient voltage suppression.

***Coil energy absorbed internally -4x nominal voltage.

Product Facts

- 500 A carry, 1300 A make overload, 3000 A break overload, @ 320 Vdc
- Hydrogen dielectric for power switching high current loads
- Auxiliary contacts
- Coil power economizing — 8 W holding
- Versatile power, voltage, and current operating range
- Excellent for safety disconnect and transfer switch applications
- Suited for circuit protection and control
- Bi-directional power switching
- Hermetically-sealed contacts; can operate in harsh environments
- Fast operate and release time
- Low power consumption

Contact Rating Notes:

1. Maximum continuous current carry = 500A @ 25°C = T_A, derate 5A/°C for higher temp.
2. Maximum interrupt power (break only) = 1 MW @ 200mH inductance.

Product Specifications

- Contact Arrangement — Form X — SPST-NO
- Auxiliary Contact (28 Vdc, 0.1 A) — SPST-NO
- Rated Resistive Load @ 320 Vdc — 300 Amps @85°C
- Continuous Current Carry, Max. @ 50°C — 500 A
- Overload Current @ 320 Vdc — Make — 1,300 A Break — 3,300 A
- Load Life, @ 320 Vdc, Min. — See chart at right
- Contact Resistance, Max. — End of Life — 0.0002 ohm
- Dielectric at Sea Level — Power Terminals to Coil and All Other Points — 1,800 Vrms
- Shock, 11ms, 1/2 Sine (Peak) — 30 g
- Vibration, Sinusoidal (55-2000 Hz, Peak) — 5 g
- Operating Ambient Temperature Range — -40°C to +85°C
- Operate Time, Including Bounce, Max., 25°C — 40 ms
- Release Time, Max. — 20 ms
- Bounce Time, Max. — 5 ms
- Insulation Resistance @ 500 Vdc, Min. — Initial — 100 mohm End of Life — 50 mohm
- Weight, Nominal — 3.4 lb (1.52 kg)

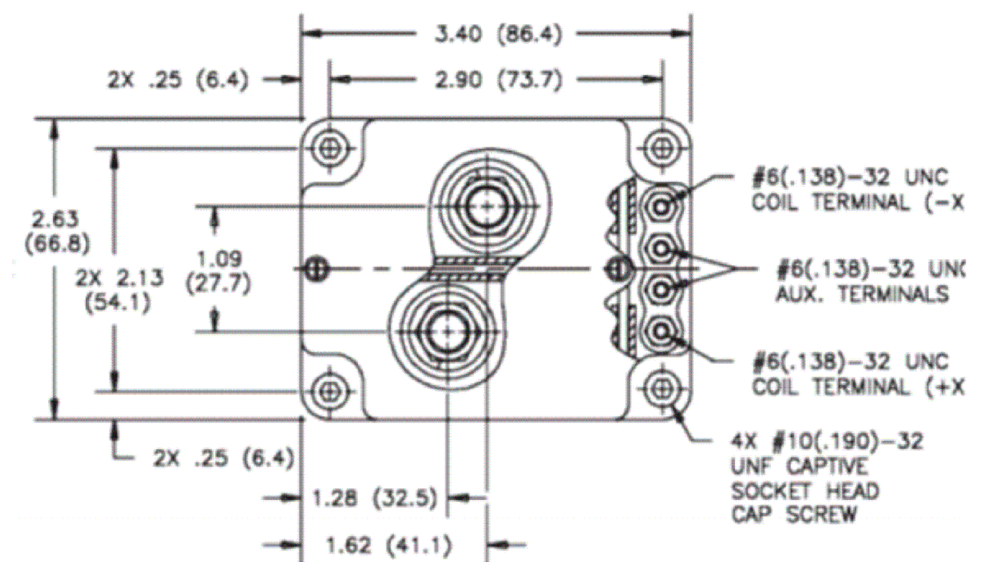

Electrical Life Cycles vs Power Switching

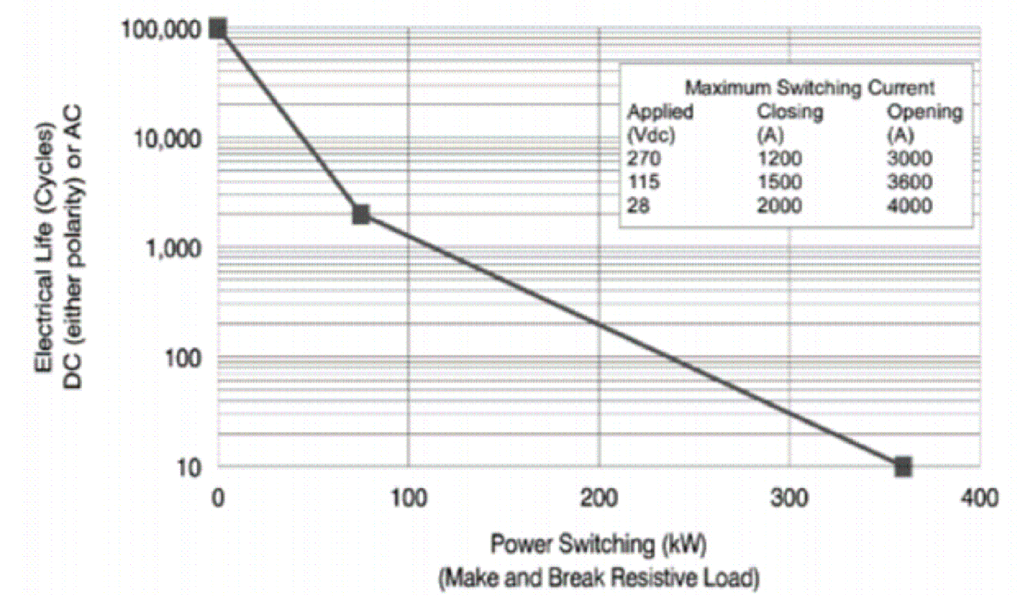

*Failure Mode: Dielectric withstand voltage test @ 2000 Vdc, power terminal to terminal, leakage exceeds 1.0 mA. Current carry: 500 A @ 25°C. Derate 2.5 A/°C to 350 A @ 85°C for still air, no heat sink, AWG# 00 conductor.

ALL DIMENSIONS ARE IN INCHES(MM)

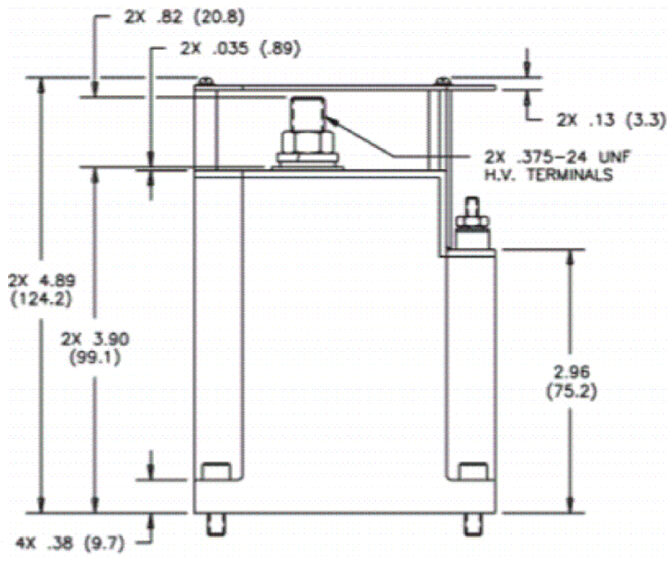

THIS DRAWING IS A CONTROLLED DOCUMENT.		DWN VM 26AUG2019	TE Connectivity		
DIMENSIONS: INCHES		CHK RV 26AUG2019			
TOLERANCES UNLESS OTHERWISE SPECIFIED:		APVD MP 26AUG2019	PD350X-500AMPS CONTACTOR MAKE AND BREAK LOAD SWITCHING		
0 PLC ± -		PRODUCT SPEC	SIZE		
1 PLC ± -		APPLICATION SPEC	CAGE CODE		
2 PLC ± -		—	DRAWING NO		
3 PLC ± -		—	RESTRICTED TO		
4 PLC ± -		—	A3		
ANGLES ± -		—	C-PD350X-CONTACTOR		
MATERIAL		WEIGHT	CUSTOMER DRAWING		
FINISH		—	SCALE	SHEET	REV
—		—	NTS	1 OF 1	A

单击下面可查看定价，库存，交付和生命周期等信息

[>>TE Connectivity\(泰科\)](#)