

PART NUMBER	REVISION	DESCRIPTION	FEED TYPE
2150059-2	F	FINE CRIMP HEIGHT ADJUST	PNEUMATIC
7-2150059-2	F	PNEUMATIC AND CRIMP TOOLING KIT	PNEUMATIC
7-2150059-7	A	CRIMP TOOLING KIT	-

ATLANTIC VERSION TERMINATOR INTERFACE ADAPTER

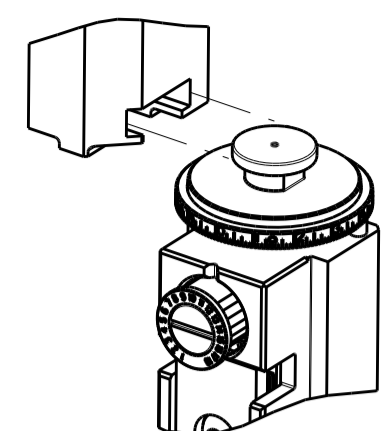

APPLICATOR DATA		
CRIMP	SIZE	TYPE
WIRE	1.57 mm [.062]	F
INSUL	3.30 mm [.130]	F
APPL INSTRUCTIONS 408-35043		

TERMINAL DATA: TE TERMINAL		TE CRIMP SPECIFICATION	
TERMINAL NAME: 187 SERIES POSITIVE LOCK RECEP			
WIRE STRIP LENGTH		INSULATION DIAMETER RANGE	
4.00-5.00 mm [.157-.197 IN]		∅1.50-2.70 mm [.059-.106 IN]	
TERMINAL APPLICATION SPECIFICATION	114-5041		
TERMINALS APPLIED			
TE TERMINAL	TE TERMINAL	TE TERMINAL	TE TERMINAL
170324-1	170324-2	170324-3	170324-5
1-170324-1	173690-1		

WIRE SIZE	CRIMP HEIGHT mm [INCH]	CRIMP HEIGHT REFERENCE SETTING
0.50mm2	1.09+/-0.05 [.043+/-0.002]	4.1
0.30mm2	1.06+/-0.05 [.042+/-0.002]	4.4
0.20mm2	1.00+/-0.05 [.039+/-0.002]	5.0

- RECOMMENDED SPARE PARTS
- REFER TO SUPPLIED INSTRUCTION SHEET FOR CLEANING, LUBRICATION AND STORAGE OF APPLICATOR.
- APPLY PART NUMBER 2-23419-6 LOCTITE TO THREADS OF ITEM 242. APPLY PART NUMBER 1-23419-5 LOCTITE TO THREADS OF ITEM 180.
- CRIMP HEIGHT REFERENCE SETTING WAS THE SETTING USED WHEN THE APPLICATOR WAS QUALIFIED AT THE FACTORY. ADJUSTMENT MAY BE NECESSARY WHEN RUNNING APPLICATOR IN THE FIELD.
- TERMINAL PITCH NOT COMPATIBLE WITH MECHANICAL FEED.
- 6. UNLESS SPECIFIED OTHERWISE TORQUE VALUES SHALL BE USED PER DOCUMENT, 101-35000.

**\*WARNING**  
ON INSTALLATION, SET WIRE DISC TO CRIMP HEIGHT REFERENCE SETTING FOR LARGEST WIRE SIZE. CRIMP HEIGHT REFERENCE SETTINGS GREATER THAN THE VALUE SHOWN MAY CAUSE DAMAGE TO THE CRIMP TOOLING. REFER TO THE INSTRUCTION SHEET FOR PROPER SETUP AND ADJUSTMENTS.

LOC	DIST	REVISIONS					
A	66	REV	LTN	DESCRIPTION	DATE	DWN	APVD
		C		ECR-18-014739	17SEP2018	TB	TE
		D		ECR-19-009342	13JUN2019	LG	TE
		E		ECR-20-003027	02MAR2020	JWC	GB
		F		ECR-20-014644	16OCT2020	FZ	RK

-	1	1	2119641-1	FEED CAM, AIR FEED	248	
-	1	1	2119082-9	CAM, SNAIL, INSULATION ADJUSTMENT	244	
-	1	1	2079764-1	WASHER, WAVE SPRING, CREST-TO-CREST	243	
	-	1	2119083-1	RETAINER, INSULATION DIAL	242	
-	1	1	2844940-3	AIR FEED MODULE	238	
-	1	1	1-18028-0	WASHER, FLAT, REG M8	192	
	-	1	1752354-8	STANDOFF, HOLD-DOWN	180	
-	1	1	6-993111-6	PIN, SLOTTED SPRING 3.0 X 14.0	177	
-	1	1	8-22280-7	SPRING, COMPRESSION	176	
-	1	1	1752353-2	GUIDE PIN, HOLDDOWN	175	
-	1	1	1901680-2	GUIDE PIN, HOLDDOWN	174	
-	REFREF		994970-2	COUNTER, MAGNETIC	164	
-	1	1	455888-5	SPACER, CRIMPER	82	
-	1	1	1803607-4	DOCUMENTATION PACKAGE	71	
-	2	2	2-18032-2	SCR, SET, FLT PNT, M3 X 10.0	70	
-	1	1	2119740-1	TAG, IDENTIFICATION	67	
-	2	2	2168078-1	SCREW, DRIVE, RH, RoHS, 2 x .188	66	
-	1	1	1901681-9	HOLDDOWN, TERMINAL	65	
-	2	2	2168400-5	SHCS, LOW HEAD, RoHS, M4 X 20	64	
-	1	1	2168083-2	SCR, SKT HD CAP, RoHS, M4 X 8.0	60	
-	1	1	5-18022-5	SCR, HEX HD CAP, M4 X 6.0	59	
-	3	3	2168400-4	SHCS, LOW HEAD, RoHS, M4 X 8	57	
-	2	2	2168083-3	SCR, SKT HD CAP, RoHS, M4 X 12.0	56	
-	2	2	5018030-1	NUT, HEX, REG, RoHS, M3	54	
-	2	2	986965-8	NUT, LOCK, HEX, TORQUE (M4)	53	
-	1	1	1-5018030-0	NUT, HEX, REG, RoHS, M3.5	52	
-	1	1	2063961-5	FEED FINGER	51	
-	1	1	18023-9	SCR, SKT HD CAP M4 X 6.0	49	
-	1	1	2119655-5	APPLICATOR BASIC ASSEMBLY, EF	46	
-	1	1	1803517-1	RAM ASSEMBLY, EF ATLANTIC	44	
-	1	1	1803602-1	SCR, BHSC, RoHS (M8 X 25)	41	
-	7	7	1-18028-2	WASHER, FLAT, REG M4	33	
-	2	2	2168083-9	SCR, SKT HD CAP, RoHS, M4 X 20	31	
-	2	2	2168083-2	SCR, SKT HD CAP, RoHS, M4 X 8.0	29	
-	1	1	240639-1	STRIPPER (MACHINING)	27	
-	2	2	1-2168083-5	SCR, SKT HD CAP, RoHS, M4 X 30	25	
-	1	1	3-1752371-9	PLATE, STRIP GUIDE	24	
-	1	1	240825-1	PLATE, STRIP HOLD DOWN	23	
-	2	2	2-22281-3	SPRING, COMPRESSION	22	
-	1	1	1803292-4	DRAG	20	
-	2	2	1901259-4	GUIDE, LOWER STRIP	18	
-	4	4	1-2079383-1	SCR, BHSC, RoHS (M6 X 12)	17	
-	1	1	1752360-1	SPACER, HOLD-DOWN	13	
	-	1	240833-1	PLATE, REAR SHEAR	11	
-	-	-	-	-	10	
	-	1	6-690482-3	PLATE, FRONT SHEAR	9	
	1	2	1333214-2	ANVIL, EF .062	8	
	-	1	1-2217206-0	BLADE, SLUG	7	
-	1	1	7-240641-5	SPACER	5	
-	1	1	238011-2	BLOCK, CRIMPER SPACER	4	
	1	2	2-1633961-6	CRIMPER, INSULATION F PREMIUM	3	
-	1	1	1-455888-0	SPACER, CRIMPER	2	
	1	2	2-456403-1	CRIMPER, WIRE PREMIUM	1	
-	77	72	2	PART NO	DESCRIPTION	ITEM NO

ATLANTIC VERSION  
Shown on sheets 1 of 4 & 2 of 4  
(Pacific version shown on sheets 3 of 4 & 4 of 4)

DIMENSIONS:		TOLERANCES UNLESS OTHERWISE SPECIFIED:		DWN: C. CHEN 25MAY2012		CHK: S. XI 25MAY2012		APVD: J. CRUZ 25MAY2012		NAME: Ocean End Feed Applicator	
mm	0 PLC ±	1 PLC ±	2 PLC ±	3 PLC ±	4 PLC ±	ANGLES	FINISH	WEIGHT	SCALE: 1:1	SHEET 1 OF 4	REV F
MATERIAL:		FINISH:		CAGE CODE: A100779		DRAWING NO: C=2150059		RESTRICTED TO:		Customer Accessible Production Drawing	

LOC	DIST	REVISIONS				
A	66	P. LTR	DESCRIPTION	DATE	DWN	APVD
		-	SEE SHEET 1	-	-	-

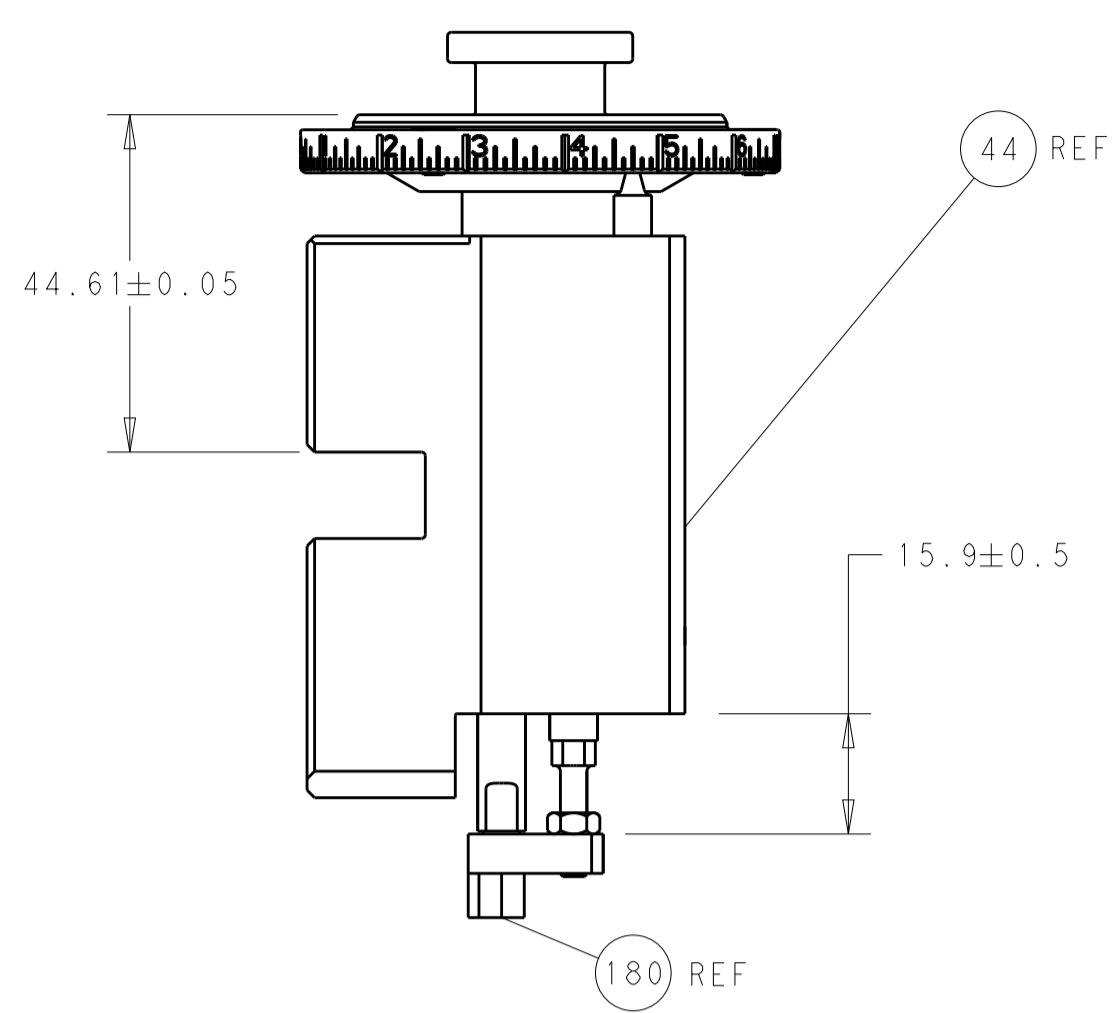

RAM AND HOLDDOWN SET-UP

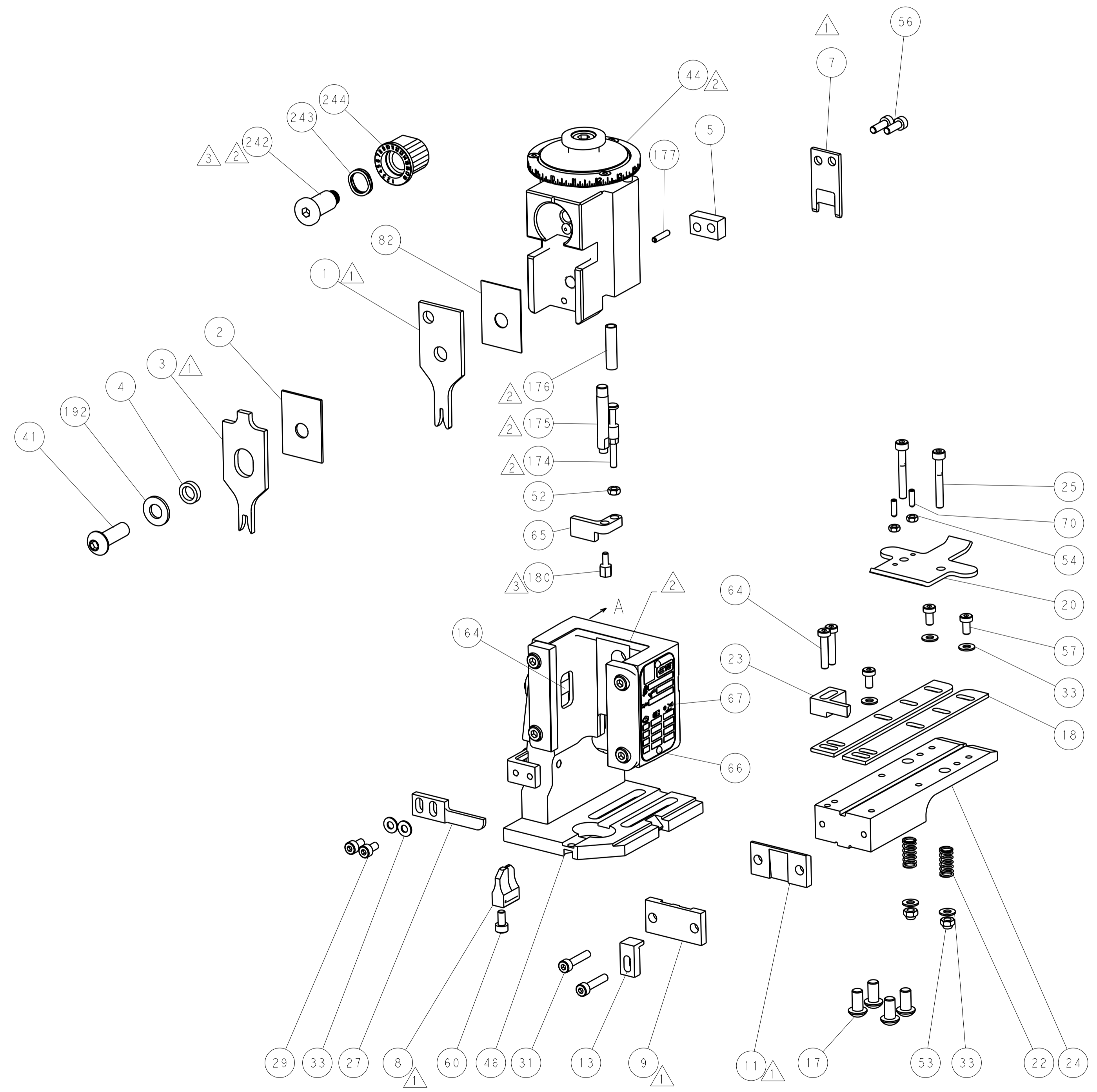

FEED TYPE

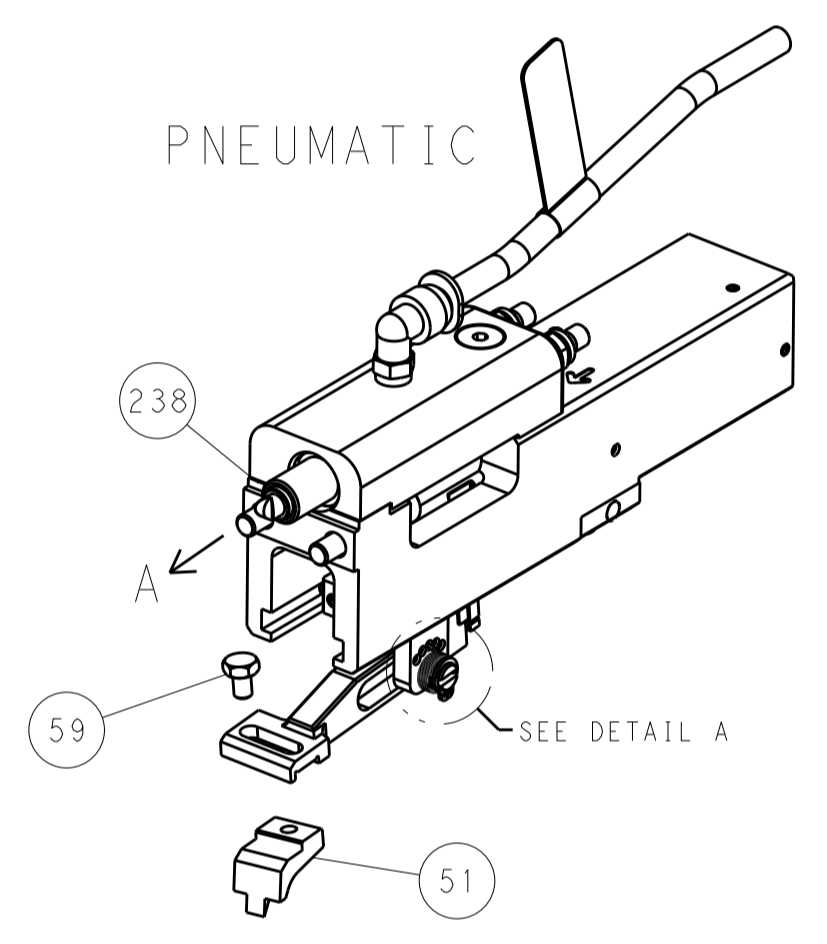

FEED SPRING SETTING POSITION

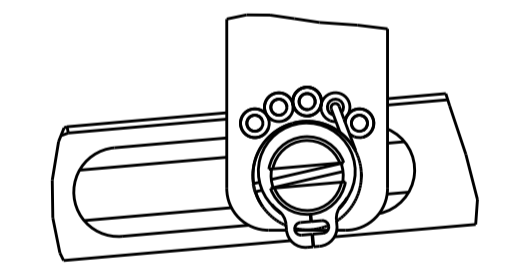

CAM POSITION

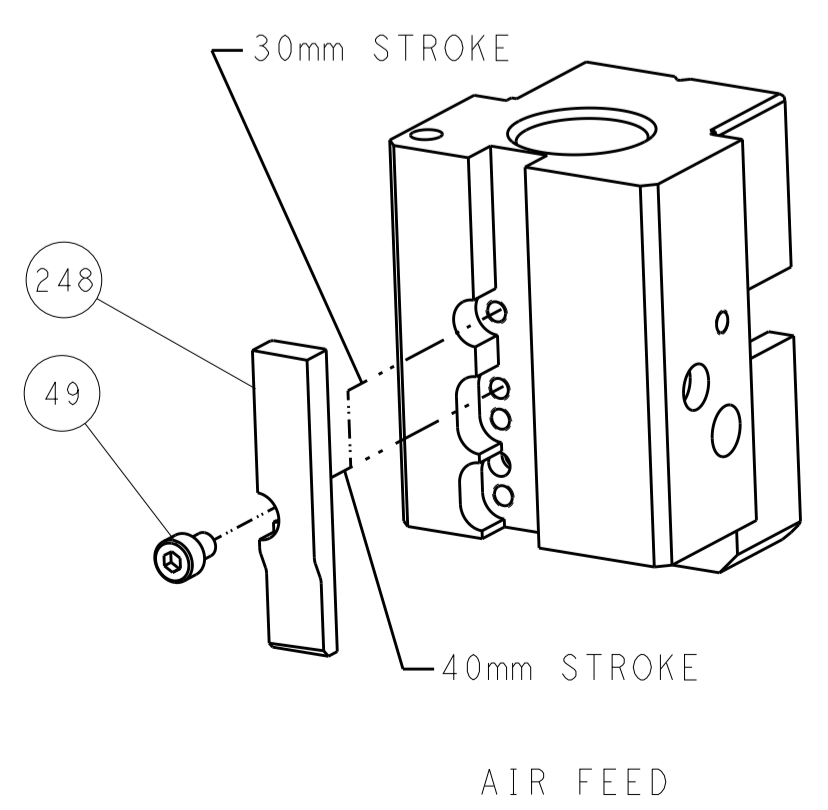

AIR FEED

ATLANTIC VERSION  
 Shown on sheets 1 of 4 & 2 of 4  
 (Pacific version shown on sheets 3 of 4 & 4 of 4)

<small>THIS DRAWING IS UNPUBLISHED. RELEASED FOR PUBLICATION BY TYCO ELECTRONICS CORPORATION. ALL RIGHTS RESERVED.</small>		DWN: C. CHEN 25MAY2012 CHK: S. XI 25MAY2012 APVD: J. CRUZ 25MAY2012	TE Connectivity Harrisburg, PA 17105-3608
DIMENSIONS: mm 		TOLERANCES UNLESS OTHERWISE SPECIFIED: 0 PLC ± 1 PLC ± 2 PLC ± 3 PLC ± 4 PLC ± ANGLES ±	NAME: Ocean End Feed Applier SIZE: A1 CAGE CODE: 00779 DRAWING NO: C=2150059 RESTRICTED TO: -
MATERIAL: - FINISH: -		WEIGHT: - SCALE: 1:1 SHEET: 2 of 4 REV: F	Customer Accessible Production Drawing



PART NUMBER	REVISION	DESCRIPTION	FEED TYPE
2-2150059-2	F	FINE CRIMP HEIGHT ADJUST	PNEUMATIC
7-2150059-7	A	CRIMP TOOLING KIT	-

PACIFIC VERSION TERMINATOR  
 INTERFACE ADAPTER

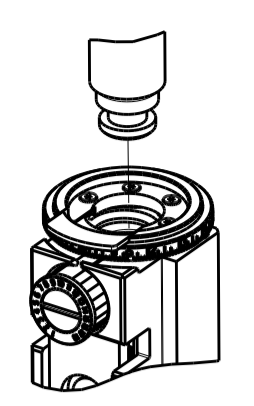

APPLICATOR DATA

CRIMP	SIZE	TYPE
WIRE	1.57 mm (.062)	F
INSUL	3.30 mm (.130)	F

APPL INSTRUCTIONS  
 408-35043

TERMINAL DATA: TE TERMINAL TE CRIMP SPECIFICATION

TERMINAL NAME: 187 SERIES POSITIVE LOCK RECEP

WIRE STRIP LENGTH	INSULATION DIAMETER RANGE
4.00-5.00 mm (.157-.197 IN)	1.50-2.70 mm (.059-.106 IN)

TERMINAL APPLICATION SPECIFICATION

TERMINALS APPLIED

TE TERMINAL	TE TERMINAL	TE TERMINAL	TE TERMINAL
170324-1	170324-2	170324-3	170324-5
1-170324-1	173690-1		

WIRE SIZE	CRIMP HEIGHT mm [INCH]	CRIMP HEIGHT REFERENCE SETTING
0.50mm2	1.09 +/- 0.05 [.043 +/- .002]	4.1
0.30mm2	1.06 +/- 0.05 [.042 +/- .002]	4.4
0.20mm2	1.00 +/- 0.05 [.039 +/- .002]	5.0



- RECOMMENDED SPARE PARTS
- REFER TO SUPPLIED INSTRUCTION SHEET FOR CLEANING, LUBRICATION AND STORAGE OF APPLICATOR.
- APPLY PART NUMBER 2-23419-6 LOCTITE TO THREADS OF ITEM 242. APPLY PART NUMBER 1-23419-5 LOCTITE TO THREADS OF ITEM 180.
- CRIMP HEIGHT REFERENCE SETTING WAS THE SETTING USED WHEN THE APPLICATOR WAS QUALIFIED AT THE FACTORY. ADJUSTMENT MAY BE NECESSARY WHEN RUNNING APPLICATOR IN THE FIELD.
- TERMINAL PITCH NOT COMPATIBLE WITH MECHANICAL FEED.
- UNLESS SPECIFIED OTHERWISE TORQUE VALUES SHALL BE USED PER DOCUMENT, 101-35000.

**\*WARNING**  
 ON INSTALLATION, SET WIRE DISC TO CRIMP HEIGHT REFERENCE SETTING FOR LARGEST WIRE SIZE. CRIMP HEIGHT REFERENCE SETTINGS GREATER THAN THE VALUE SHOWN MAY CAUSE DAMAGE TO THE CRIMP TOOLING. REFER TO THE INSTRUCTION SHEET FOR PROPER SETUP AND ADJUSTMENTS.

LOC	DIST	REV	LTN	DESCRIPTION	DATE	OWN	APVD
A	66	-	-	SEE SHEET 1	-	-	-

-	1	2119082-9	CAM, SNAIL, INSULATION ADJUSTMENT	244
-	1	2079764-1	WASHER, WAVE SPRING, CREST-TO-CREST	243
-	1	2119083-1	RETAINER, INSULATION DIAL	242
-	1	2844940-3	AIR FEED MODULE	238
-	1	1-18028-0	WASHER, FLAT, REG M8	192
-	4	2079383-9	SCR, BHSC, RoHS (M6 X 20)	186
-	1	1752354-8	STANDOFF, HOLD-DOWN	180
-	1	6-993111-6	PIN, SLOTTED SPRING 3.0 X 14.0	177
-	1	8-22280-7	SPRING, COMPRESSION	176
-	1	1752353-2	GUIDE PIN, HOLDDOWN	175
-	1	1901680-2	GUIDE PIN, HOLDDOWN	174
-	REF	994970-2	COUNTER, MAGNETIC	164
-	1	2119641-2	FEED CAM, AIR FEED	152
-	1	2168083-8	SCR, SKT HD CAP, RoHS, M4 X 16	144
-	1	2119655-6	APPLICATOR BASIC ASSEMBLY, EF	141
-	1	1803518-1	RAM ASSEMBLY, EF PACIFIC	140
-	1	455888-5	SPACER, CRIMPER	82
-	1	1803607-4	DOCUMENTATION PACKAGE	71
-	2	2-18032-2	SCR, SET, FLT PNT, M3 X 10.0	70
-	1	2119740-1	TAG, IDENTIFICATION	67
-	2	2168078-1	SCREW, DRIVE, RH, RoHS, 2 x .188	66
-	1	1901681-9	HOLDDOWN, TERMINAL	65
-	2	2168400-5	SHCS, LOW HEAD, RoHS, M4 X 20	64
-	1	5-18022-5	SCR, HEX HD CAP, M4 X 6.0	59
-	3	2168400-4	SHCS, LOW HEAD, RoHS, M4 X 8	57
-	2	2168083-3	SCR, SKT HD CAP, RoHS, M4 X 12.0	56
-	2	5018030-1	NUT, HEX, REG, RoHS, M3	54
-	2	986965-8	NUT, LOCK, HEX, TORQUE (M4)	53
-	1	1-5018030-0	NUT, HEX, REG, RoHS, M3.5	52
-	1	2063961-5	FEED FINGER	51
-	1	18023-9	SCR, SKT HD CAP M4 X 6.0	49
-	1	1803602-1	SCR, BHSC, RoHS (M8 X 25)	41
-	7	1-18028-2	WASHER, FLAT, REG M4	33
-	2	2168083-9	SCR, SKT HD CAP, RoHS, M4 X 20	31
-	2	2168083-2	SCR, SKT HD CAP, RoHS, M4 X 8.0	29
-	1	240639-1	STRIPPER (MACHINING)	27
-	2	1-2168083-5	SCR, SKT HD CAP, RoHS, M4 X 30	25
-	1	3-1752371-9	PLATE, STRIP GUIDE	24
-	1	240825-1	PLATE, STRIP HOLD DOWN	23
-	2	2-22281-3	SPRING, COMPRESSION	22
-	1	1803292-4	DRAG	20
-	2	1901259-4	GUIDE, LOWER STRIP	18
-	1	1752360-1	SPACER, HOLD-DOWN	13
-	1	240833-1	PLATE, REAR SHEAR	11
-	-	-	-	10
-	1	6-690482-3	PLATE, FRONT SHEAR	9
1	1	1333214-2	ANVIL, EF .062	8
-	1	1-2217206-0	BLADE, SLUG	7
-	1	7-240641-5	SPACER	5
-	1	238011-2	BLOCK, CRIMPER SPACER	4
1	1	2-1633961-6	CRIMPER, INSULATION F PREMIUM	3
-	1	1-455888-0	SPACER, CRIMPER	2
1	1	2-456403-1	CRIMPER, WIRE PREMIUM	1

PACIFIC VERSION  
 Shown on sheets 3 of 4 & 4 of 4  
 (Atlantic version shown on sheets 1 of 4 & 2 of 4)

DIMENSIONS: mm 		TOLERANCES UNLESS OTHERWISE SPECIFIED: 0 PLC ± 1 PLC ± 2 PLC ± 3 PLC ± 4 PLC ± ANGLES ± FINISH ±		DWN: C. CHEN 25MAY2012 CHK: S. XI 25MAY2012 APVD: J. CRUZ 25MAY2012		TE Connectivity Harrisburg, PA 17105-3608	
MATERIAL: - FINISH: -		WEIGHT: - SCALE: 1:1		SIZE: A1 CAGE CODE: 00779 DRAWING NO: 2150059		RESTRICTED TO: - SHEET 3 OF 4 REV F	

LOC		DIST		REVISIONS			
A		66		REV	DATE	BY	APPV
				1	SEE SHEET 1		

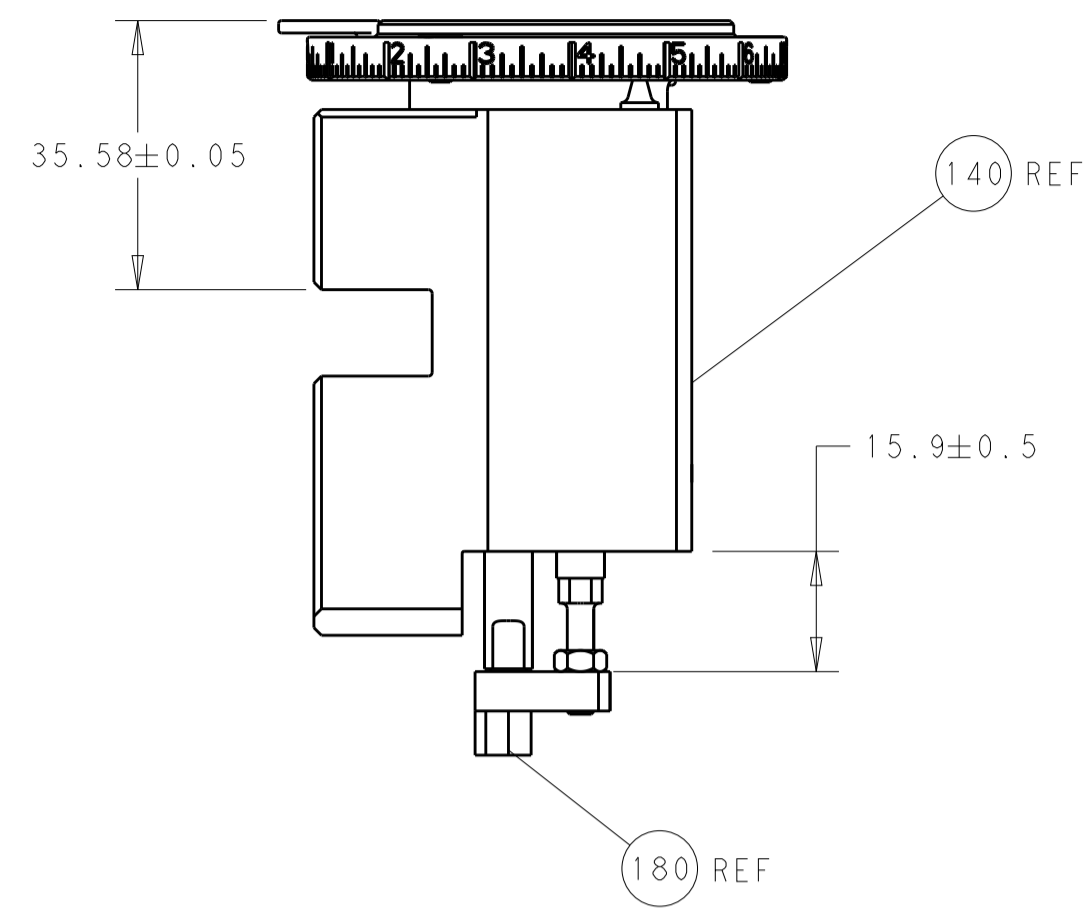

RAM AND HOLDDOWN SET-UP

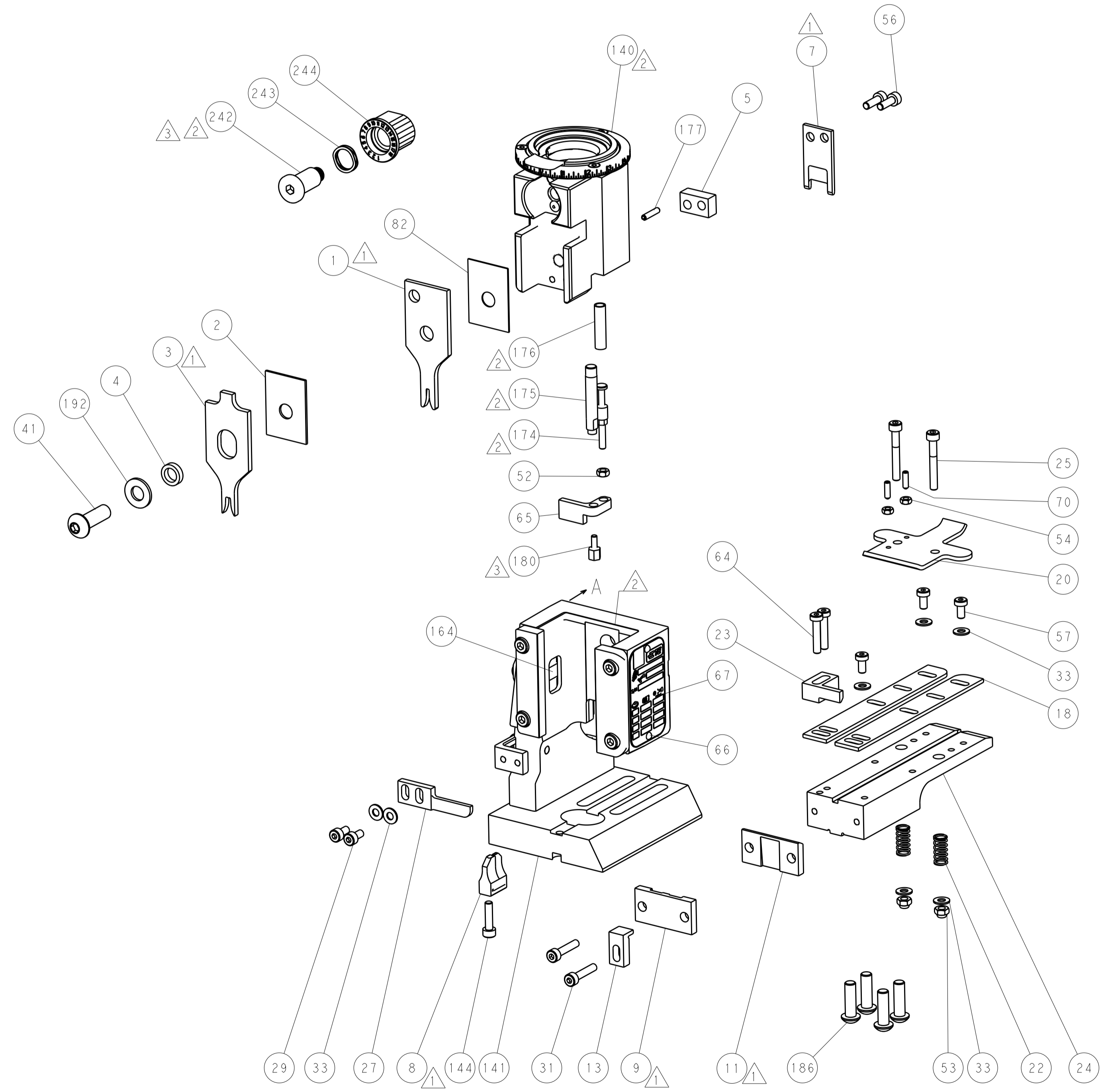

FEED TYPE

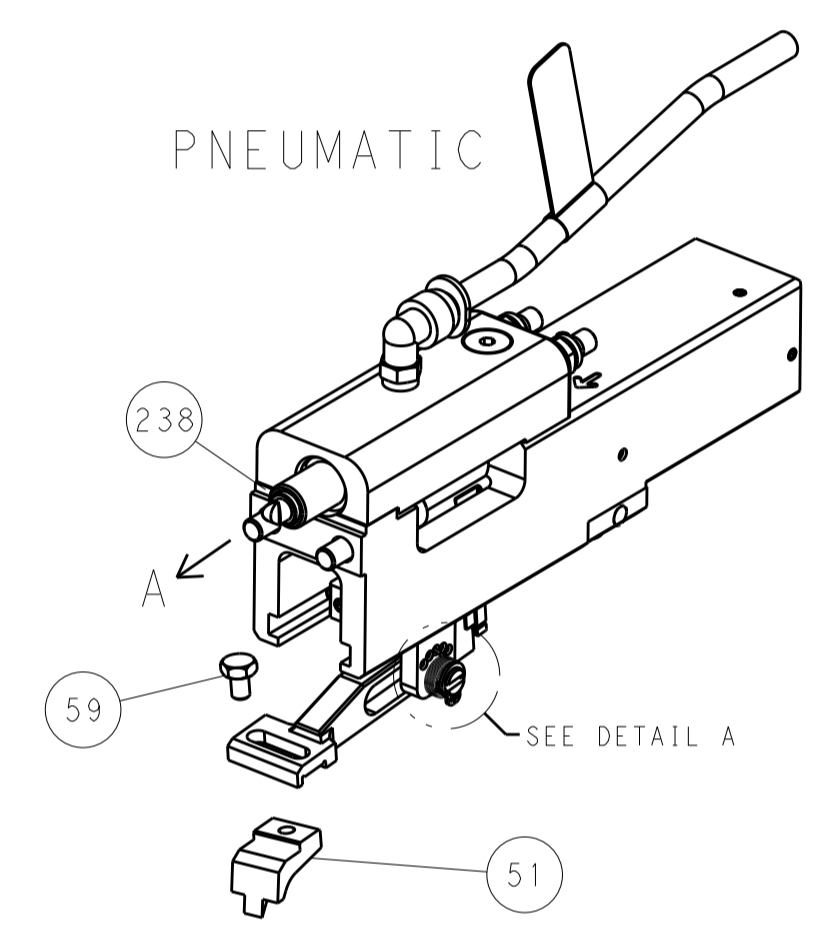

FEED SPRING SETTING POSITION

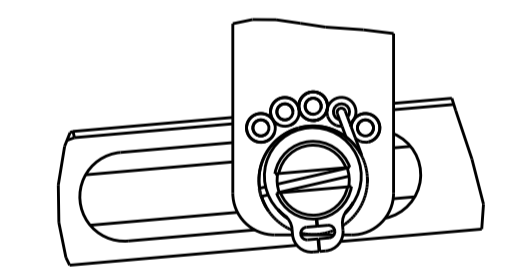

DETAIL A

CAM POSITION

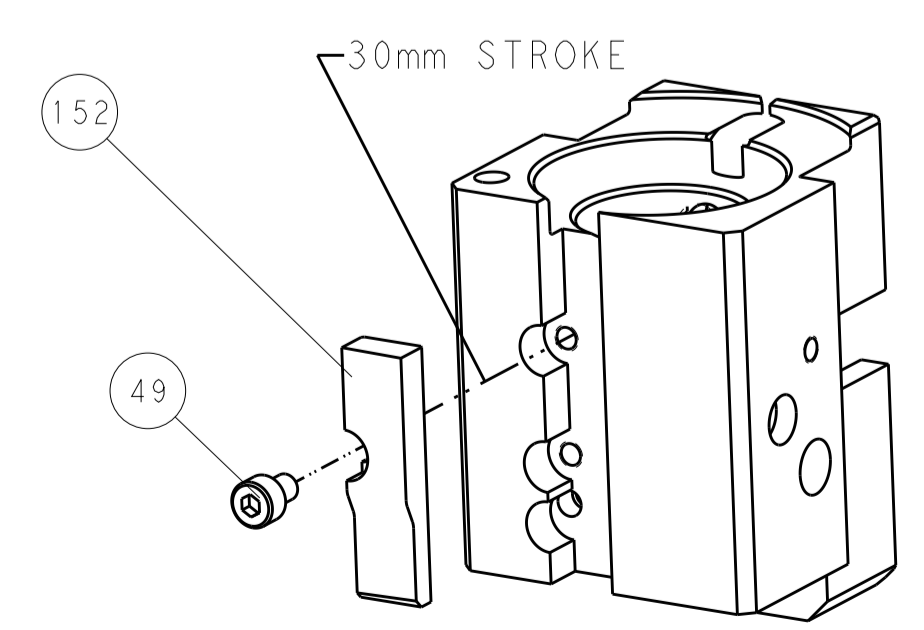

AIR FEED

PACIFIC VERSION  
 Shown on sheets 3 of 4 & 4 of 4  
 (Atlantic version shown on sheets 1 of 4 & 2 of 4)

DIMENSIONS:		TOLERANCES UNLESS OTHERWISE SPECIFIED:		DWN C. CHEN 25MAY2012		STE TE Connectivity	
mm		0 PLC ±		CHK S. XI 25MAY2012		Harrisburg, PA 17105-3608	
HOLE		1 PLC ±		APVD J. CRUZ 25MAY2012		NAME	
MATERIAL		2 PLC ±		PRODUCT SPEC		Ocean End Feed	
		3 PLC ±		APPLICATION SPEC		Applicator	
		4 PLC ±		WEIGHT		SIZE CAGE CODE DRAWING NO RESTRICTED TO	
		ANGLES ±		A 00779 C=2150059		4 of 4 REV F	
		FINISH		Customer Accessible Production Drawing		SCALE 1:1 SHEET 4 OF 4 REV F	

单击下面可查看定价，库存，交付和生命周期等信息

[>>TE Connectivity\(泰科\)](#)