

TPS1H200A-Q1 40-V 200-mΩ Single-Channel Smart High-Side Switch

1 Features

- Qualified for automotive applications
- AEC-Q100 qualified with the following results:
 - Device temperature grade 1: -40°C to $+125^{\circ}\text{C}$ ambient operating temperature range
 - Device HBM ESD Classification Level H2
 - Device CDM ESD Classification Level C4B
- **Functional Safety-Capable**
 - [Documentation available to aid functional safety system design](#)
- Single-channel 200-mW smart high-side switch
- Wide operating voltage: 3.4 V to 40 V
- Ultra-low standby current, < 500 nA
- Adjustable current limit with external resistor
 - $\pm 15\%$ when ≥ 500 mA
 - $\pm 10\%$ when ≥ 1.5 A
- Configurable behavior after current limit
 - Holding mode
 - Latch-off mode with adjustable delay time
 - Auto-retry mode
- Supports stand-alone operation without an MCU
- Protection:
 - Short-to-GND and overload protection
 - Thermal shutdown and thermal swing
 - Negative voltage clamp for inductive loads
 - Loss of GND and loss of battery protection

- Diagnostics:
 - Overload and short-to-GND detection
 - Open-load and short-to-battery detection in ON or OFF state
 - Thermal shutdown and thermal swing

2 Applications

- Body lighting
- Infotainment system
- Advanced Driver Assistance Systems (ADAS)
- Single-channel high-side switch for submodules
- General resistive, inductive, and capacitive loads

3 Description

The TPS1H200A-Q1 device is a fully protected single-channel high-side power switch with an integrated 200-mΩ NMOS power FET.

An adjustable current limit improves system reliability by limiting the inrush or overload current. The high accuracy of the current limit improves overload protection, simplifying the front-stage power design. Configurable features besides current limit provide design flexibility in functionality, cost, and thermal dissipation.

The device supports full diagnostics with the digital status output. Open-load detection is available in ON and OFF states. The device supports operation with or without an MCU. Stand-alone mode allows isolated systems to use the device.

Device Information⁽¹⁾

PART NUMBER	PACKAGE	BODY SIZE (NOM)
TPS1H200A-Q1	HVSSOP (8)	3.00 mm × 3.00 mm

- (1) For all available packages, see the orderable addendum at the end of the data sheet.

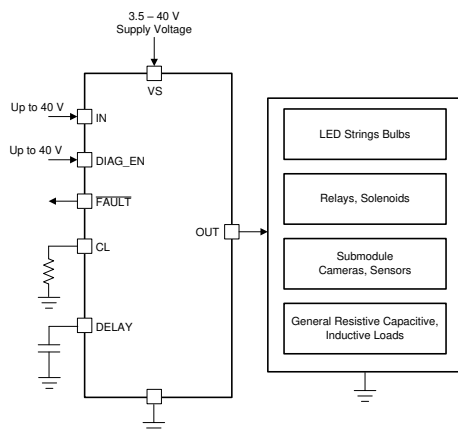

Typical Block Diagram

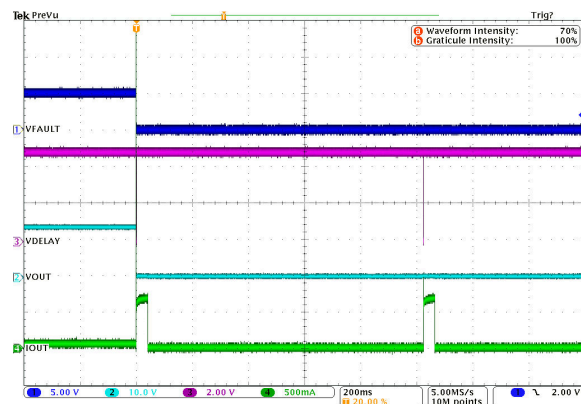

Current Limit Protection in Auto-Retry Mode



Table of Contents

1 Features	1	7.4 Device Functional Modes.....	24
2 Applications	1	8 Application and Implementation	25
3 Description	1	8.1 Application Information.....	25
4 Revision History	2	8.2 Typical Application.....	25
5 Pin Configuration and Functions	3	9 Power Supply Recommendations	27
6 Specifications	4	10 Layout	27
6.1 Absolute Maximum Ratings.....	4	10.1 Layout Guidelines.....	27
6.2 ESD Ratings.....	4	10.2 Layout Example.....	27
6.3 Recommended Operating Conditions.....	5	11 Device and Documentation Support	28
6.4 Thermal Information.....	5	11.1 Documentation Support.....	28
6.5 Electrical Characteristics.....	6	11.2 Receiving Notification of Documentation Updates..	28
6.6 Switching Characteristics.....	8	11.3 Support Resources.....	28
6.7 Typical Characteristics.....	9	11.4 Trademarks.....	28
7 Detailed Description	11	11.5 Electrostatic Discharge Caution.....	28
7.1 Overview.....	11	11.6 Glossary.....	28
7.2 Functional Block Diagram.....	11	12 Mechanical, Packaging, and Orderable Information	29
7.3 Feature Description.....	12		

4 Revision History

NOTE: Page numbers for previous revisions may differ from page numbers in the current version.

Changes from Revision C (December 2019) to Revision D (September 2021)	Page
• Changed the nominal operating current ($I_{(OP)}$) V_{DIAG_EN} variable to "X" for do not care in the <i>Electrical Characteristics</i> table.....	6
Changes from Revision B (December 2019) to Revision C (December 2019)	Page
• Added Functional safety capable to the <i>Features</i> section	1
Changes from Revision A (April 2018) to Revision B (December 2019)	Page
• Changed the Logic high-level voltage from 2 V to 1.8 V in the <i>Electrical Characteristics</i> table.....	6
• Changed the IN and DIAG_EN from high to low in the <i>Standby Mode</i> section.....	24
Changes from Revision * (February 2018) to Revision A (April 2018)	Page
• Changed data sheet status from Advanced Information to Production Data	1

5 Pin Configuration and Functions

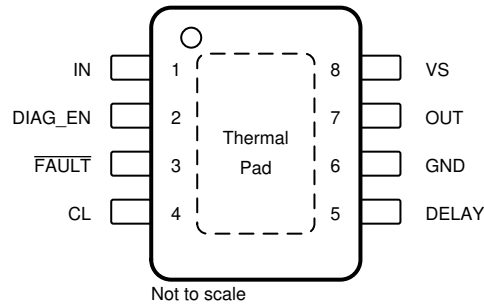

Figure 5-1. DGN PowerPAD™ Package 8-Pin HVSSOP With Exposed Thermal Pad Top View

Table 5-1. Pin Functions

PIN		I/O	DESCRIPTION
NAME	NO.		
CL	4	O	Adjustable current limit. Connect to device GND if external current limit is not used.
DELAY	5	I/O	Function configuration when current limit; internal pullup
DIAG_EN	2	I	Enable the diagnostic function
FAULT	3	O	Open-drain diagnostic status output. Leave floating if not used.
GND	6	—	Ground
IN	1	I	Input control for output activation; internal pulldown
OUT	7	O	Output, source of the high-side switch, connected to the load
VS	8	I	Power supply, drain for the high-side switch
Thermal pad	—	—	Thermal pad. Connect to device GND or leave floating.

6 Specifications

6.1 Absolute Maximum Ratings

over operating ambient temperature range (unless otherwise noted)⁽¹⁾ ⁽²⁾

		MIN	MAX	UNIT
Supply voltage VS pin	t < 400 ms	—	42	V
Reverse polarity voltage ⁽³⁾	t < 1 minute	-36	—	V
Current on GND	t < 2 minutes	-100	250	mA
Voltage on IN and DIAG_EN pins		-0.3	VS	V
Current on IN and DIAG_EN pins		-10	—	mA
Voltage on DELAY pin		-0.3	7	V
Current on DELAY pin		-60	—	mA
Voltage on $\overline{\text{FAULT}}$ pin		-0.3	7	V
Current on $\overline{\text{FAULT}}$ pin		-30	10	mA
Voltage on CL pin		-0.3	7	V
Current on CL pin		—	6	mA
Voltage on OUT pin		—	42	V
Inductive load switch-off energy dissipation single pulse ⁽⁴⁾		—	40	mJ
Operating junction temperature, T _J		-40	150	°C
Storage temperature, T _{stg}		-65	150	°C

- (1) Stresses beyond those listed under *Absolute Maximum Ratings* may cause permanent damage to the device. These are stress ratings only, which do not imply functional operation of the device at these or any other conditions beyond those indicated under *Recommended Operating Conditions*. Exposure to absolute-maximum-rated conditions for extended periods may affect device reliability.
- (2) All voltage values are with respect to ground.
- (3) Reverse polarity condition: V_{IN} = 0 V, reverse current < I_{R(2)}, GND pin 1-kΩ resistor in parallel with diode.
- (4) Test condition: V_{VS} = 13.5 V, L = 8 mH, T_J = 150°C. FR4 2s2p board, 2 × 70-μm Cu, 2 × 35-μm Cu. 600 mm² thermal pad copper area.

6.2 ESD Ratings

		VALUE	UNIT
V _(ESD) Electrostatic discharge	Human-body model (HBM), per AEC Q100-002 ⁽¹⁾	All pins except VS, OUT, and GND	±2000
		Pins VS, OUT, and GND	±3000
	Charged-device model (CDM), per AEC Q100-011	±750	V

- (1) AEC-Q100-002 indicates that HBM stressing shall be in accordance with the ANSI/ESDA/JEDEC JS-001 specifications.

6.3 Recommended Operating Conditions

over operating ambient temperature range (unless otherwise noted)

		MIN	MAX	UNIT
V_S	Operating voltage	4	40	V
	Voltage on IN and DIAG_EN pins	0	40	V
	Voltage on $\overline{\text{FAULT}}$ pin	0	5	V
$I_{o,nom}$	Nominal DC load current	0	2.5	A
T_J	Operating junction temperature	-40	150	°C

6.4 Thermal Information

THERMAL METRIC ⁽¹⁾		TPS1H200A-Q1	UNIT
		DGN (HVSSOP)	
		8 PINS	
$R_{\theta JA}$	Junction-to-ambient thermal resistance	47.4	°C/W
$R_{\theta JC(top)}$	Junction-to-case (top) thermal resistance	49.2	°C/W
$R_{\theta JB}$	Junction-to-board thermal resistance	18.3	°C/W
Ψ_{JT}	Junction-to-top characterization parameter	0.8	°C/W
Ψ_{JB}	Junction-to-board characterization parameter	18.4	°C/W
$R_{\theta JC(bot)}$	Junction-to-case (bottom) thermal resistance	5.6	°C/W

- (1) For more information about traditional and new thermal metrics, see the [Semiconductor and IC Package Thermal Metrics application report](#).

6.5 Electrical Characteristics

over operating ambient temperature range (unless otherwise noted)

PARAMETER		TEST CONDITIONS	MIN	TYP	MAX	UNIT
OPERATING VOLTAGE						
$V_{VS(nom)}$	Nominal operating voltage		4		40	V
$V_{VS(uvr)}$	Undervoltage restart	V_{VS} rising	3.5	3.7	4	V
$V_{VS(uvf)}$	Undervoltage shutdown	V_{VS} falling	3	3.2	3.4	V
$V_{(uv,hys)}$	Undervoltage shutdown, hysteresis			0.5		V
OPERATING CURRENT						
$I_{(op)}$	Nominal operating current	$V_{VS} = 13.5\text{ V}$, $V_{IN} = 5\text{ V}$ $V_{DIAG_EN} = X\text{ V}$, $I_{OUT} = 0.5\text{ A}$ $I_{CL} = 2\text{ A}$			5	mA
$I_{(off)}$	Standby current	$V_{VS} = 13.5\text{ V}$ $V_{IN} = V_{DIAG_EN} = V_{CL} = V_{OUT} = 0\text{ V}$ $T_J = 25^\circ\text{C}$			0.5	μA
		$V_{VS} = 13.5\text{ V}$ $V_{IN} = V_{DIAG_EN} = V_{CL} = V_{OUT} = 0\text{ V}$ $T_J = 125^\circ\text{C}$			3	
$I_{(off,diag)}$	Standby current with diagnostics enabled	$V_{VS} = 13.5\text{ V}$ $V_{IN} = 0\text{ V}$, $V_{DIAG_EN} = 5\text{ V}$			3	mA
$t_{(off,deg)}$	Standby-mode deglitch time ⁽¹⁾	IN from high to low if deglitch time $\geq t_{(off,deg)}$, then the device enters into standby mode.		12.5		ms
$I_{lkg(out)}$	Output leakage current in OFF state	$V_{VS} = 13.5\text{ V}$ $V_{IN} = V_{DIAG_EN} = V_{OUT} = 0\text{ V}$			3	μA
POWER STAGE						
$r_{DS(on)}$	ON state resistance	$V_{VS} \geq 3.5\text{ V}$, $T_J = 25^\circ\text{C}$		200		m Ω
		$V_{VS} \geq 3.5\text{ V}$, $T_J = 150^\circ\text{C}$			400	
$I_{CL(int)}$	Internal current limit	CL pin connected to GND	3.5	4.8	6	A
$I_{CL(TSD)}$	Current-limit value percentage during thermal shutdown			60%		
$V_{DS(clamp)}$	Drain-to-source voltage internally clamped		45		65	V
OUTPUT DIODE CHARACTERISTICS						
V_F	Drain-to-source diode voltage	IN = 0, $I_{OUT} = -0.15\text{ A}$	0.3	0.7	1	V
$I_{R(1)}$	Continuous reverse current from source to drain during a short-to-battery condition ⁽¹⁾	$t < 60\text{ s}$, $V_{IN} = 0\text{ V}$, $T_J = 25^\circ\text{C}$.			2	A
$I_{R(2)}$	Continuous reverse current from source to drain during a reverse-polarity condition ⁽¹⁾	$t < 60\text{ s}$, $V_{IN} = 0\text{ V}$, $T_J = 25^\circ\text{C}$ GND pin 1-k Ω resistor in parallel with diode.			2	A
LOGIC INPUT (IN, DIAG_EN)						
V_{IH}	Logic high-level voltage		1.8			V
V_{IL}	Logic low-level voltage				0.8	V
$R_{pd,in}$	Logic-pin pulldown resistor	IN. $V_{IN} = 5\text{ V}$	150		400	k Ω
		DIAG_EN. $V_{VS} = V_{DIAG_EN} = 5\text{ V}$	350		850	
DIAGNOSTICS						
$I_{lkg(loss,GND)}$	Loss of ground output leakage current				100	μA
$t_{d(ol,on)}$	Open-load deglitch time in ON state	$V_{IN} = 5\text{ V}$, $V_{DIAG_EN} = 5\text{ V}$ when $I_{OUT} < I_{(ol,on)}$, duration longer than $t_{d(ol,on)}$, open load is detected.	200	300	450	μs

6.5 Electrical Characteristics (continued)

over operating ambient temperature range (unless otherwise noted)

PARAMETER		TEST CONDITIONS	MIN	TYP	MAX	UNIT
$I_{(ol,on)}$	Open-load detection threshold in ON state	$V_{IN} = 5\text{ V}$, $V_{DIAG_EN} = 5\text{ V}$ when $I_{OUT} < I_{(ol,on)}$ duration longer than $t_{d(ol,on)}$ open load is detected.		10	20	mA
$V_{(ol,off)}$	Open-load detection threshold in OFF state	$V_{IN} = 0\text{ V}$, $V_{DIAG_EN} = 5\text{ V}$ when $V_{VS} - V_{OUT} < V_{(ol,off)}$ duration longer than $t_{d(ol,off)}$ open load is detected.	1.4		2.6	V
$t_{d(ol,off)}$	Open-load deglitch time in OFF state	$V_{IN} = 0\text{ V}$, $V_{DIAG_EN} = 5\text{ V}$ when $V_{VS} - V_{OUT} < V_{(ol,off)}$ duration longer than $t_{d(ol,off)}$ open load is detected.	200	300	450	μs
$I_{(ol,off)}$	OFF state output sink current	$V_{IN} = 0\text{ V}$, $V_{DIAG_EN} = 5\text{ V}$ $V_{VS} = V_{OUT} = 13.5\text{ V}$	-75			μA
V_{FAULT}	\overline{FAULT} low output voltage	$I_{FAULT} = 2\text{ mA}$			0.2	V
t_{FAULT}	\overline{FAULT} signal holding time ⁽¹⁾			8.5		ms
$T_{(SD)}$	Thermal shutdown threshold ⁽¹⁾			175		$^{\circ}\text{C}$
$T_{(SD,rst)}$	Thermal shutdown status reset ⁽¹⁾			155		$^{\circ}\text{C}$
$T_{(sw)}$	Thermal swing shutdown threshold ⁽¹⁾			60		$^{\circ}\text{C}$
$T_{(hys)}$	Hysteresis for resetting the thermal shutdown and swing ⁽¹⁾			10		$^{\circ}\text{C}$
CURRENT LIMIT AND DELAY CONFIGURATION						
$K_{(CL)}$	Current-limit current ratio ⁽¹⁾			2500		
$V_{CL(th)}$	Current-limit internal threshold voltage ⁽¹⁾			0.8		V
$dK_{(CL)} / K_{(CL)}$	External current limit accuracy ($I_{OUT} - I_{CL} \times K_{(CL)} \times 100 / (I_{CL} \times K_{(CL)})$)	$I_{limit} \geq 0.25\text{ A}$, $V_{VS} - V_{OUT} \geq 2.5\text{ V}$	-20%		20%	
		$I_{limit} \geq 0.5\text{ A}$, $V_{VS} - V_{OUT} \geq 2.5\text{ V}$	-15%		15%	
		$I_{limit} \geq 1.5\text{ A}$, $I_{limit} < 5\text{ A}$ $V_{VS} - V_{OUT} \geq 2.5\text{ V}$	-10%		10%	
$I_{dl(chg)}$	Delay pin charging current in latch-off mode ⁽¹⁾			4.5		μA
$V_{dl(th)}$	Pulling up threshold in auto-retry mode		2.7			V
$V_{dl(ref)}$	Internal reference voltage in latch-off mode			1.45		V
t_{dl1}	Internal fixed delay time ⁽¹⁾		300	400	500	μs
t_{dl2}	Adjustable delay time by external capacitor on DELAY pin ⁽¹⁾	Connect with 3.3 μF capacitor as the maximum value.			1000	ms
$t_{CL(deg)}$	Deglitch time when current limit ⁽¹⁾	IN low to high or IN keeps high but thermal shutdown recovery, $V_{DIAG_EN} = 5\text{ V}$ the deglitch time from IN rising edge to FAULT reporting out.	300		550	μs
		IN keeps high, $V_{DIAG_EN} = 5\text{ V}$ the deglitch time from CL start-point to FAULT reporting out.	80		200	
$t_{hic(on)}$	On-time when in auto-retry mode ⁽¹⁾		35	40	45	ms
$t_{hic(off)}$	Off-time when in auto-retry mode ⁽¹⁾		0.8	1	1.2	s

(1) Value specified by design, not subject to production test.

6.6 Switching Characteristics

PARAMETER		TEST CONDITIONS	MIN	TYP	MAX	UNIT
$t_{d(on)}$	Turnon delay time IN rising edge to 10% of V_{OUT} (1)	$V_{VS} = 13.5\text{ V}$, $V_{DIAG_EN} = 5\text{ V}$, $I_{OUT} = 0.1\text{ A}$	20	50	90	μs
$t_{d(off)}$	Turnoff delay time IN falling edge to 90% of V_{OUT} (1)	$V_{VS} = 13.5\text{ V}$, $V_{DIAG_EN} = 5\text{ V}$, $I_{OUT} = 0.1\text{ A}$	20	50	90	μs
$dV/dt_{(on)}$	Slew rate on V_{OUT} from 10% to 90% (1)	$V_{VS} = 13.5\text{ V}$, $V_{DIAG_EN} = 5\text{ V}$, $I_{OUT} = 0.1\text{ A}$	0.1	0.3	0.6	$\text{V}/\mu\text{s}$
$dV/dt_{(off)}$	Slew rate off V_{OUT} from 90% to 10% (1)	$V_{VS} = 13.5\text{ V}$, $V_{DIAG_EN} = 5\text{ V}$, $I_{OUT} = 0.1\text{ A}$	0.1	0.35	0.6	$\text{V}/\mu\text{s}$

(1) Value specified by design, not subject to production test.

6.7 Typical Characteristics

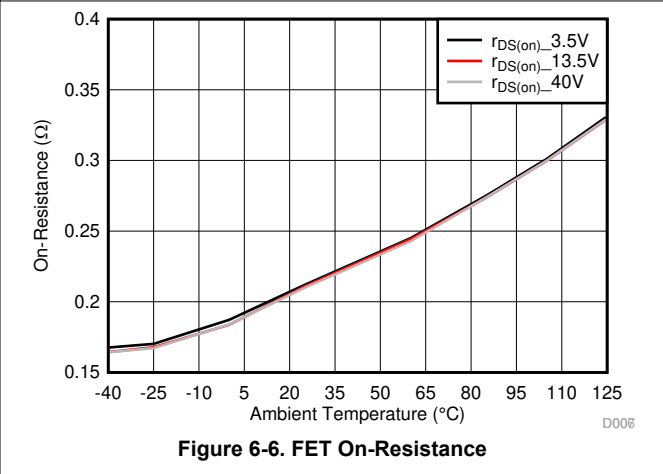
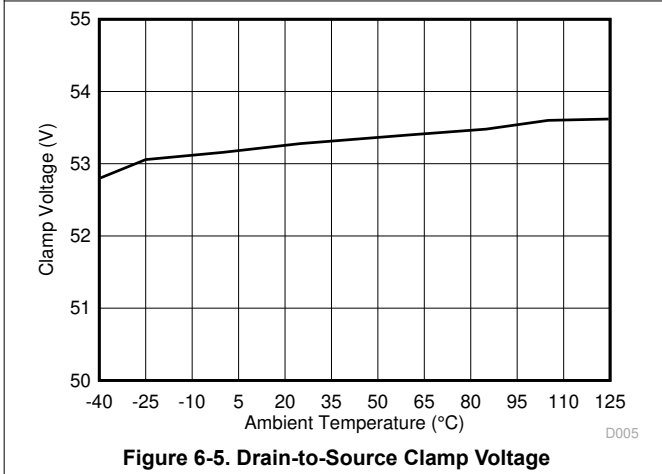
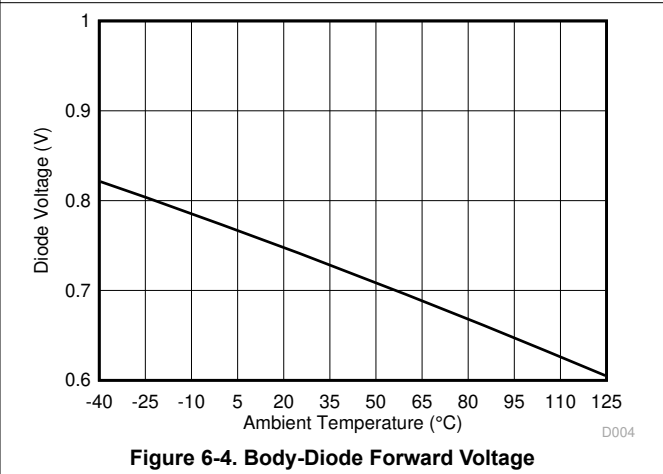
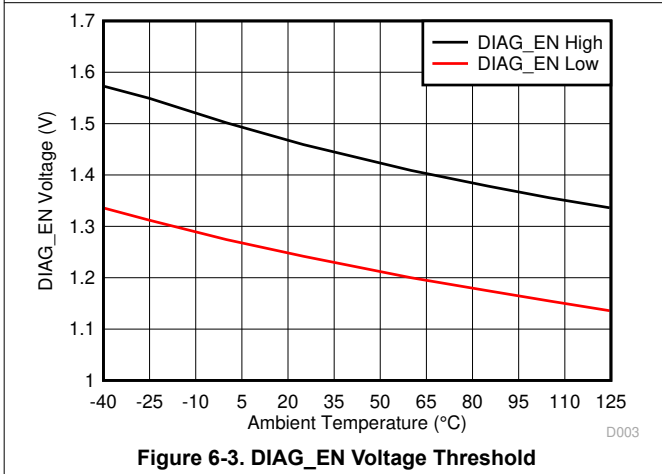
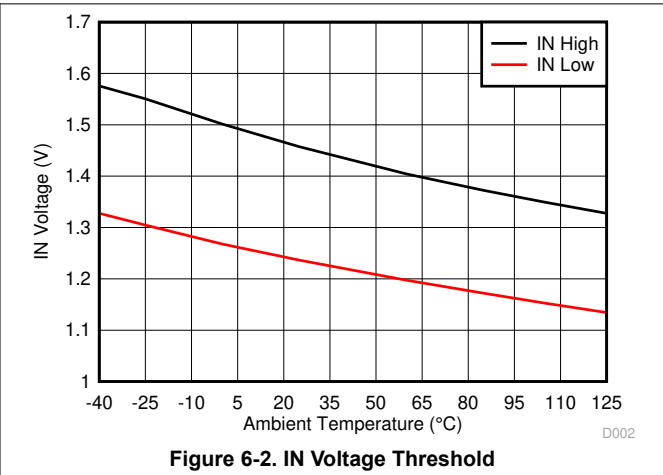
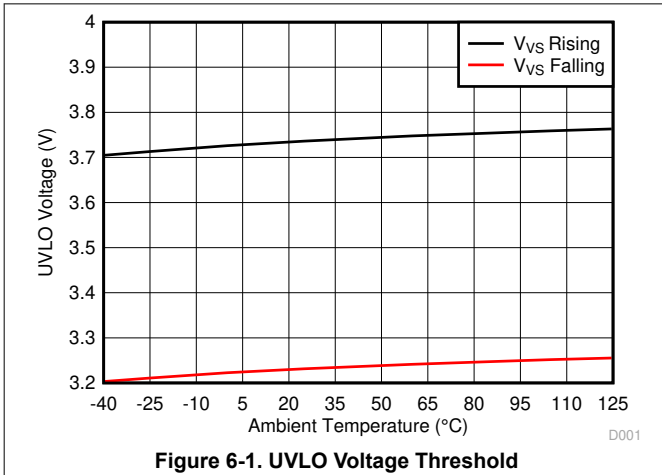

6.7 Typical Characteristics (continued)

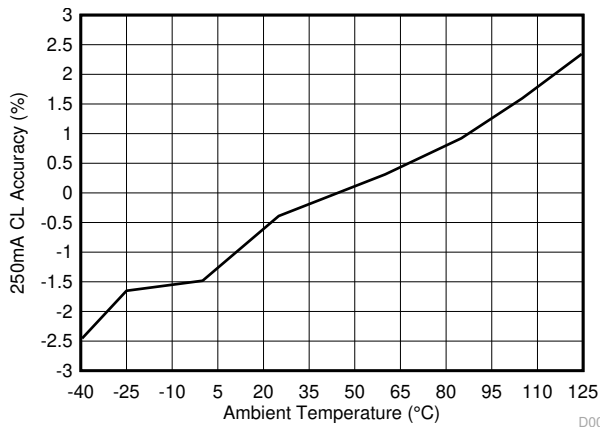

Figure 6-7. Current-Limit Accuracy at 250 mA

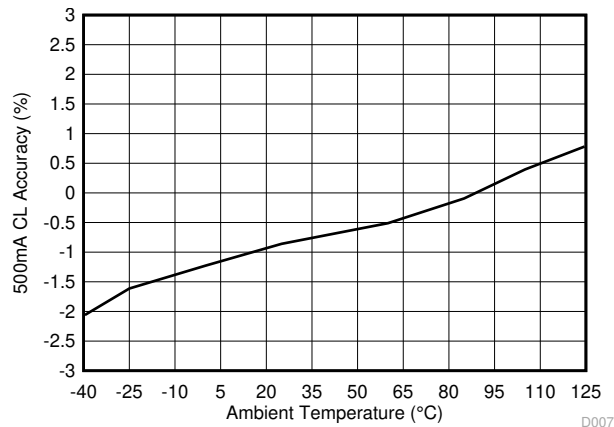

Figure 6-8. Current-Limit Accuracy at 500 mA

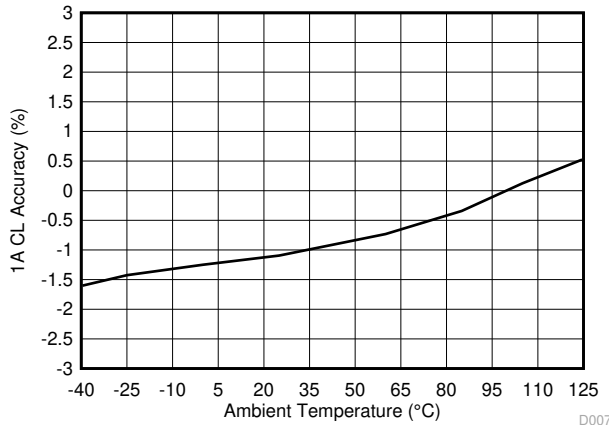

Figure 6-9. Current-Limit Accuracy at 1 A

7 Detailed Description

7.1 Overview

The TPS1H200A-Q1 device is a smart high-side switch with an internal charge pump and single-channel integrated NMOS power FET. The adjustable current limit function improves the reliability of the whole system. Full diagnostic features enable intelligent control of the load.

The external high-accuracy current limit sets the current limit value for the application. When overcurrent occurs, the device improves system reliability by clamping the inrush current effectively. The device saves system cost by reducing the size of PCB traces and connectors, and the capacity of the preceding power stage. The TPS1H200A-Q1 device allows three modes when a current limit occurs. Users can set the output to consistently hold the current, to immediately latch off, or to automatically retry through the configuration on the DELAY pin. The configurable behaviors during a current limit provide design flexibility. This includes functionality, cost, and thermal dissipation.

This device supports full diagnostics with the digital status output. High-accuracy and low-threshold open-load detection enables real-time ON state monitoring. The device supports operation without an MCU (stand-alone mode) which allows the system to locally implement full functionality.

The TPS1H200A-Q1 device is a smart high-side switch for a wide variety of resistive, inductive, and capacitive loads, including LEDs, bulbs, relays, solenoids, and submodules.

7.2 Functional Block Diagram

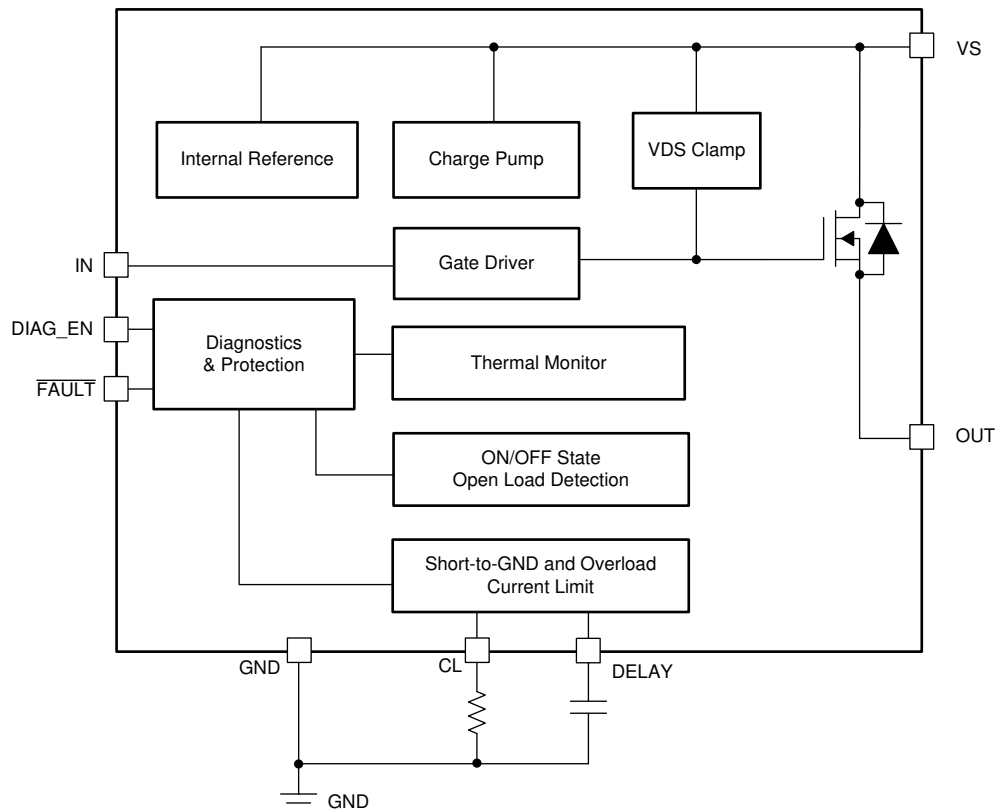

7.3 Feature Description

7.3.1 Current limit

A high-accuracy current limit allows high reliability of the design. The current limit protects the load and the power supply from overstressing during short-circuit-to-GND or power-up conditions. The current limit can also save system cost by reducing the size of PCB traces and connectors, and the capacity of the preceding power stage.

When a current limit threshold is hit, a closed loop immediately activates. The output current is clamped at the set value, and a fault is reported. The device heats up because of high power dissipation on the power FET.

The device has two current limit thresholds.

- **Internal current limit:** The internal current limit is fixed at $I_{CL(int)}$. Tie the CL pin directly to the device GND for large-transient-current applications.
- **External adjustable current limit:** An external resistor is used to set the current limit threshold. Use [Equation 1](#) to calculate $R_{(CL)}$. The external adjustable current limit allows the flexibility to set the current limit value by application.

$$R_{CL} = \frac{V_{CL(th)} \times K_{(CL)}}{I_{OUT}} \quad (1)$$

where

- $V_{CL(th)}$ is the internal band-gap voltage.
- $K_{(CL)}$ is the ratio of the output current and the current limit set value.
- $K_{(CL)}$ is constant across temperature and supply voltage.

Note

When a GND network is used, that causes a level shift between the device GND and board GND, so the CL pin must be connected to the device GND.

For better protection from a hard short-to-GND condition (when the IN pin is enabled, a short-to-GND occurs suddenly), the device will implement a fast-trip protection to turn off the output before the current limit closed loop is set up. Typically, the fast-trip response time is less than 1 μ s. With a fast response like this, the device can achieve a better inrush current-suppression performance.

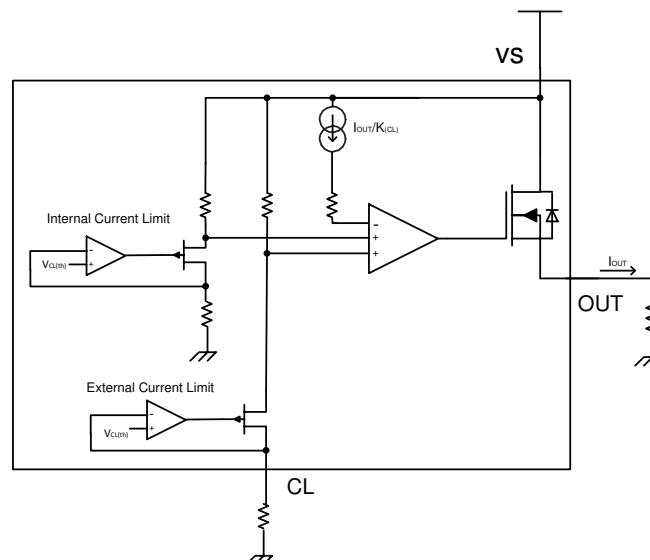

Figure 7-1. Current Limit

7.3.2 DELAY Pin Configuration

When a current limit occurs, the TPS1H200A-Q1 device supports three different outcomes of the output. Table 7-1 lists the current limit configurations and these outcomes behaviors.

Table 7-1. Current Limit Configurations

MODE	DELAY CONFIGURATION	OUTPUT CURRENT BEHAVIOR	FAULT RECOVERY
Holding	Connects to GND directly	When hitting a current limit, the output current holds at the setting current. The device enters into thermal shutdown mode when $T_J > T_{(SD)}$.	FAULT clears when IN turns low for a duration of time longer than t_{FAULT} or when the current limit is removed when IN is high.
Latch-off	Connects to GND through a capacitor	When hitting a current limit, the output current holds at the setting current, but latches off after a preset DELAY time ($t_{dl1} + t_{dl2}$). t_{dl1} is the default delay time, and t_{dl2} is a capacitor-configurable delay time. The output stays latched off regardless of whether the current limit is removed. The output recovers only when IN is toggling.	FAULT clears when IN turns low for a duration of time longer than t_{FAULT} .
Auto-retry	External pullup	When hitting a current limit, the output current holds at the setting current, but periodically comes on for $t_{hic(on)}$ and turns off for $t_{hic(off)}$.	FAULT clears when IN turns low for a duration of time longer than t_{FAULT} OR when the current limit is removed for $t_{hic(on)}$.

7.3.2.1 Holding Mode

Holding mode is active when the DELAY pin connects directly to GND. When a current limit is reached, the output current holds at the setting current. The device then enters thermal shutdown mode when $T_J > T_{(SD)}$.

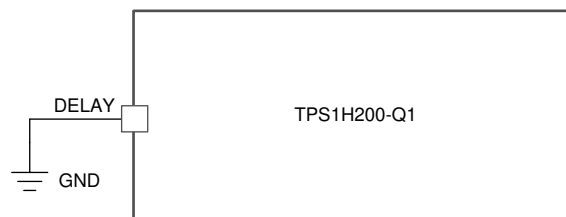

Figure 7-2. Holding Mode Connection

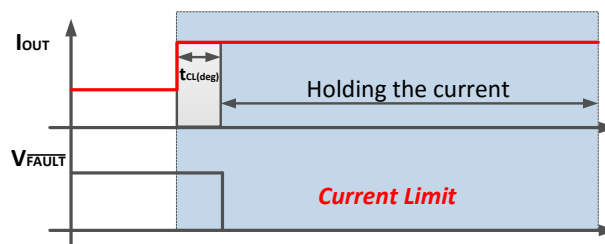

Figure 7-3. Holding Mode Example

7.3.2.2 Latch-Off Mode

Latch-off mode is active when the DELAY pin connects to GND through a capacitor. When a current limit is reached, the output current holds at the setting current, but latches off after a preset DELAY time ($t_{dl1} + t_{dl2}$). t_{dl1} is the default delay time, and t_{dl2} is a configurable delay time set by a capacitor. Regardless of whether the current limit is removed or not, the output remains latched off. The output only recovers when IN is toggling.

t_{dl2} can be calculated by Equation 2.

$$C_{\text{DELAY}} = \frac{I_{\text{dl(chg)}} \times t_{\text{dl2}}}{V_{\text{dl(ref)}}} \quad (2)$$

where

- C_{DELAY} is the capacitor connected on the DELAY pin.
- The $I_{\text{dl(chg)}}$ is the device that charges the current in latch-off mode.
- t_{dl2} is the user-setting delay time.
- $V_{\text{dl(ref)}}$ is the internal reference voltage in latch-off mode.

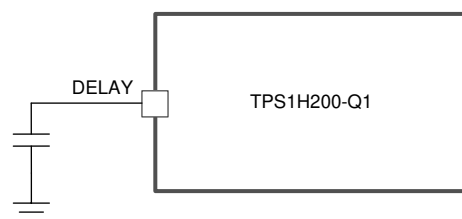

Figure 7-4. Latch-Off-Mode Connection

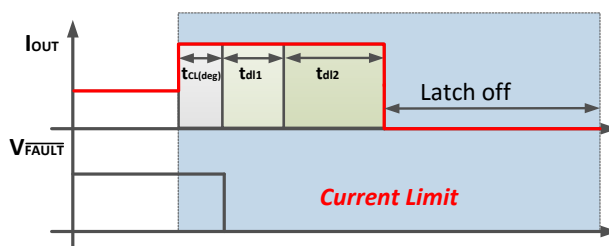

Figure 7-5. Latch-Off-Mode Example

7.3.2.3 Auto-Retry Mode

Auto-retry mode is active when the DELAY pin is externally pulled up. The pullup voltage must be higher than $V_{dI(th)}$. When the current limit is reached, the output current holds at the setting current, but periodically turns on for $t_{hic(on)}$ and turns off for $t_{hic(off)}$. The device checks the current limit status at the falling edge of $t_{hic(on)}$ clock. If current limit status is captured, the device shuts down for $t_{hic(off)}$. If the current limit status is not captured because of the off window during the thermal conditions, the device keeps turning on for additional $t_{hic(on)}$ or more until the current limit status is captured.

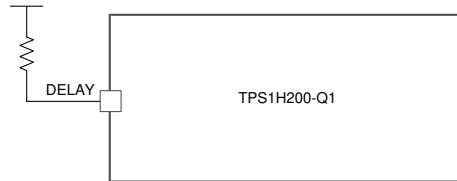

Figure 7-6. Auto-Retry-Mode Connection

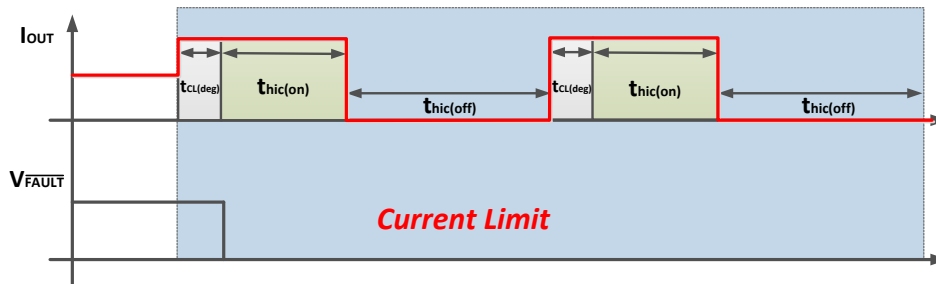

Figure 7-7. Auto-Retry-Mode Example

7.3.3 Stand-alone Operation

In a typical application, the TPS1H200A-Q1 device is controlled by a microcontroller. The device also supports stand-alone operation. IN and DIAG_EN have a 40-V maximum DC rating, and can be connected to the VS pin directly. When in auto-retry mode, the DELAY pin is connected to the VS pin through a 100-kΩ resistor.

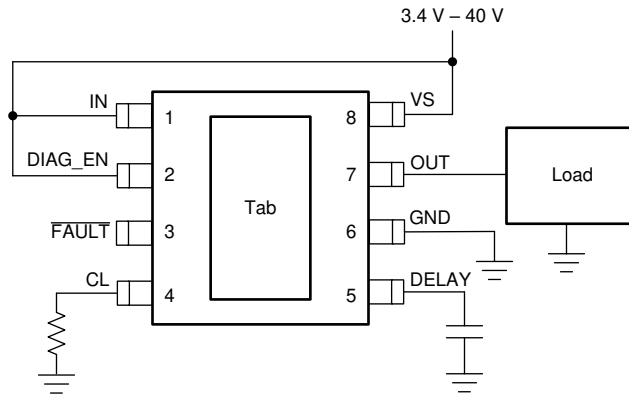

Figure 7-8. Stand-Alone Operation in Latch-Off Mode

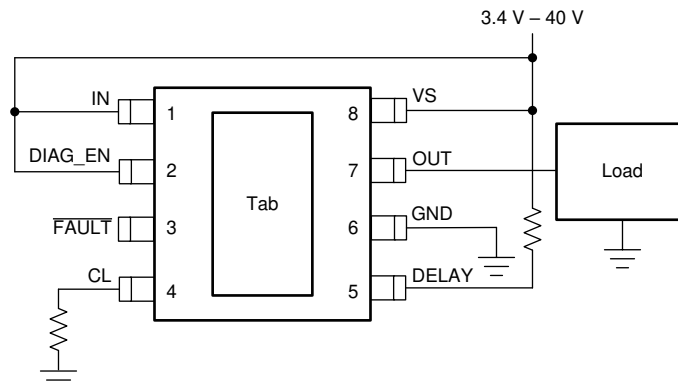

Figure 7-9. Stand-Alone Operation in Auto-Retry Mode

7.3.4 Fault Truth Table

The DIAG_EN pin enables or disables the diagnostic functions. If multiple devices are used, but the ADC resource is limited in the microcontroller, the microcontroller uses GPIOs to set DIAG_EN high to enable the diagnostics of one device, and disables the diagnostics of the other devices by setting DIAG_EN low. Additionally, the device can keep power consumption to a minimum by setting DIAG_EN and IN low.

Table 7-2 applies when the DIAG_EN pin is enabled, and Table 7-3 applies when the DIAG_EN pin is disabled.

Table 7-2. Fault Truth Table

CONDITION	IN	OUT	CRITERION	FAULT	FAULT RECOVERY
Normal	L	L	N/A	H	N/A
	H	H	N/A	H	
Overload or short to GND	H	L	current limit triggered	L	See Table 7-1.
Open load or short to battery	H	H	$I_{OUT} < I_{(ol,on)}$	L	\overline{FAULT} clears when IN turns low for a duration longer than t_{FAULT} . OR \overline{FAULT} clears when the open load is removed.
	L ⁽¹⁾	H	$V_{VS} - V_{OUT} < V_{(ol,off)}$	L	\overline{FAULT} clears when IN is toggling OR \overline{FAULT} clears when the open load is removed.
Thermal shutdown	H	N/A	Thermal shutdown triggered	L	\overline{FAULT} clears when IN turns low for a duration longer than t_{FAULT} . OR \overline{FAULT} clears when thermal shutdown quits.
Thermal swing	H	N/A	Thermal swing triggered	L	\overline{FAULT} clears when IN turns low for a duration longer than t_{FAULT} . OR \overline{FAULT} clears when thermal swing quits.

(1) An external pullup is required for open-load detection.

Table 7-3. DIAG_EN Disabled Condition

DIAG_EN	IN CONDITION	PROTECTIONS AND DIAGNOSTICS
LOW	ON	Diagnostics disabled, full protections
	OFF	Diagnostics disabled, no protection

7.3.5 Full Diagnostics

7.3.5.1 Short-to-GND and Overload Detection

When the output is on, a short-to-GND or overload condition causes an overcurrent. If the overcurrent triggers the internal or external current limit threshold, the fault condition is reported as \overline{FAULT} pin = low.

7.3.5.2 Open-Load Detection

7.3.5.2.1 Output On

When the output is on, the device recognizes an open-load fault if the current flowing through the output $I_{OUT} < I_{(ol,on)}$. For open-load detection when output is on, no external circuitry is required.

7.3.5.2.2 Output Off

When the output is off, the output is pulled down to GND if a load is connected. But if an open load occurs, the output voltage is close to the supply voltage ($V_{VS} - V_{OUT} < V_{(ol,off)}$), and the device recognizes an open-load fault.

There is always a leakage current $I_{(ol,off)}$ on the output due to the internal logic control path or external humidity, corrosion, and so forth. As a result, TI recommends using an external pullup resistor to offset the leakage current when an open load is detected. The recommended pullup resistance is 15 k Ω .

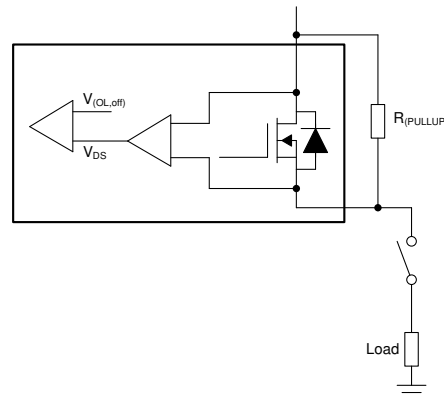

Figure 7-10. Open-Load Detection in Output OFF State

7.3.5.3 Short-to-Battery Detection

Short-to-battery has the same detection mechanism and behavior as open-load detection in the ON state and the OFF state.

7.3.5.4 Thermal Fault Detection

To protect the device in severe power stressing cases, the device implements two types of thermal fault detection, absolute temperature protection (thermal shutdown) and dynamic temperature protection (thermal swing).

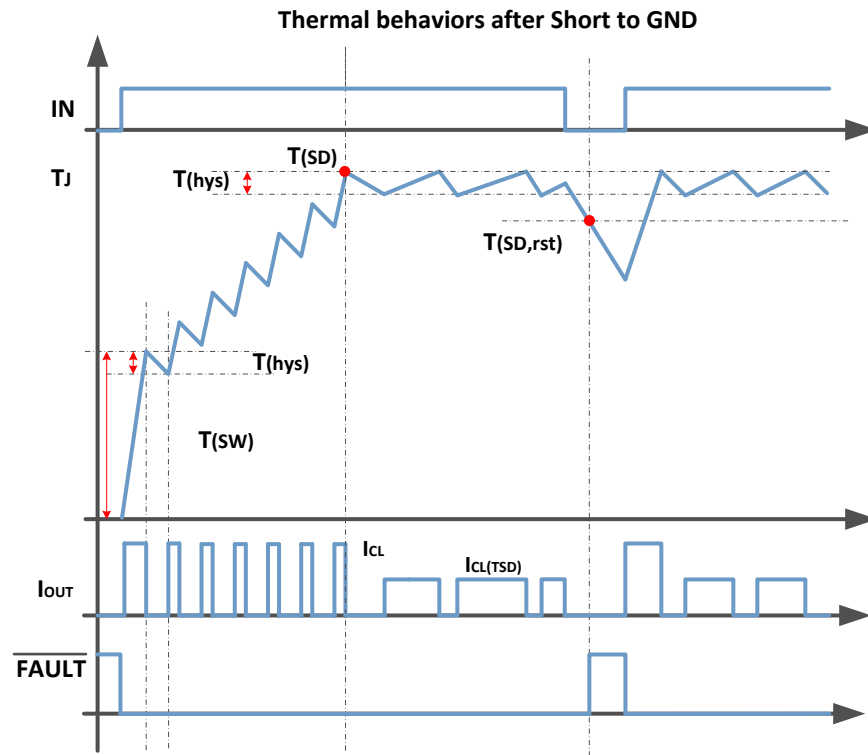

Figure 7-11. Thermal Behavior Diagram

7.3.5.4.1 Thermal Shutdown

Thermal shutdown is active when the absolute temperature $T_J > T_{(SD)}$. When thermal shutdown occurs, the output turns off.

7.3.5.4.2 Thermal Swing

Thermal swing activates when the power FET temperature sharply increases, that is, when $\Delta T = T_{(FET)} - T_{(Logic)} > T_{(sw)}$, then the output turns off. The output automatically recovers and the fault signal clears when $\Delta T = T_{(FET)} - T_{(Logic)} < T_{(sw)} - T_{(hys)}$. The thermal swing function improves the reliability of the device when subjected to repetitively fast thermal variation.

7.3.5.4.3 Fault Report Holding

When using PWM dimming, \overline{FAULT} is easily cleared by the PWM falling edge. Even if the fault condition remains all the time, \overline{FAULT} is discontinuous. To avoid this unexpected fault report behavior, the device implements fault report holding time. Figure 7-12 shows an issue that typically occurs during PWM dimming, the \overline{FAULT} is cleared unexpectedly even when the short-to-GND still exists. The TPS1H200A-Q1 device with fault-report holding function allows the right behavior as shown in Figure 7-13.

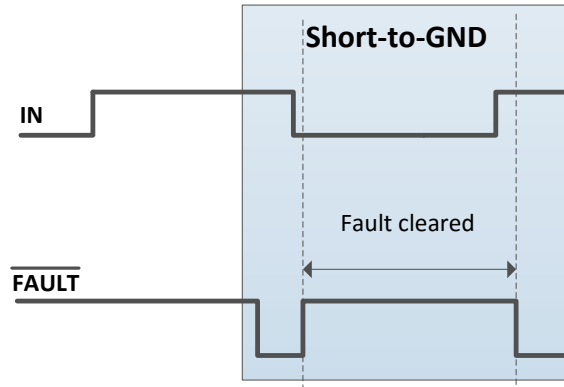

Figure 7-12. Without Fault-Report Holding

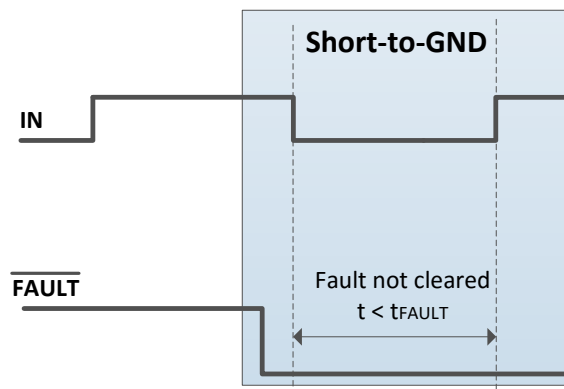

Figure 7-13. With Fault-Report Holding

7.3.6 Full Protections

7.3.6.1 UVLO Protection

The device monitors the supply voltage, V_{VS} , to prevent unpredicted behaviors when V_{VS} is too low. When V_{VS} drops down to $V_{VS(uvf)}$, the device shuts down. When V_{VS} rises up to $V_{VS(uvr)}$, the device turns on.

7.3.6.2 Inductive Load Switching Off Clamp

When an inductive load is switched off, the inductive reactance pulls the output voltage negative. However, excessive negative voltage can cause the power FET to break down. To protect the power FET from breaking down, an internal clamp ($V_{DS(clamp)}$) is implemented.

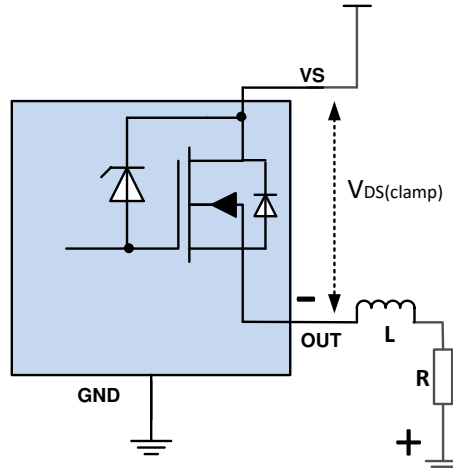

Figure 7-14. Drain-to-Source Clamping Structure

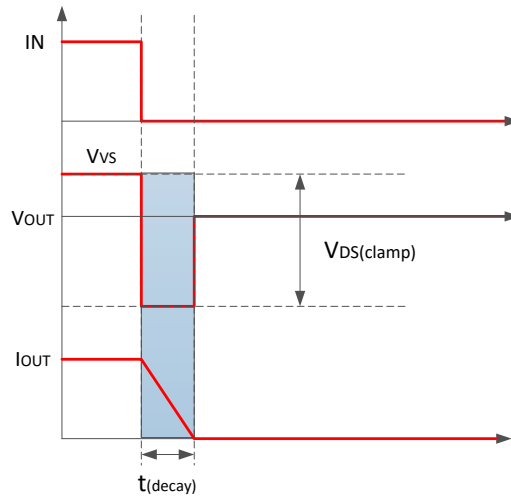

Figure 7-15. Inductive-Load Switching-Off Diagram

7.3.6.3 Loss-of-GND Protection

When a loss-of-GND occurs, the output shuts down, regardless of whether the IN pin is high or low. The device can protect against two ground-loss conditions, loss of device GND and loss of module GND.

7.3.6.4 Loss-of-Power-Supply Protection

When a loss-of-power-supply occurs, the output shuts down, regardless of whether the IN pin is high or low. For a resistive or a capacitive load, the loss-of-power-supply has no risk. But for a charged inductive load, the current is driven from all the logic control pins to maintain the inductance current. To protect the system in this condition, TI recommends protection with an external free-wheeling diode.

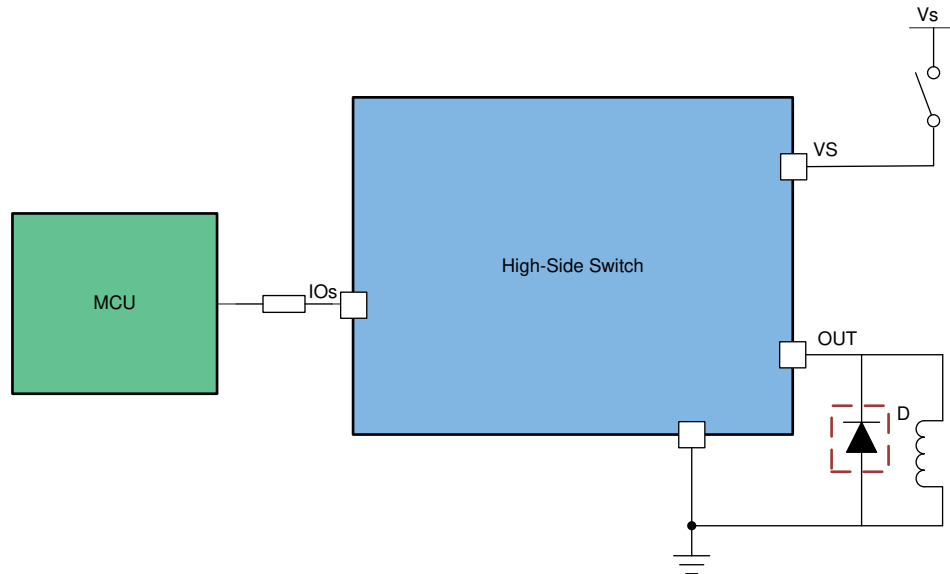

Figure 7-16. Protection for Loss of Power Supply

7.3.6.5 Reverse-Current Protection

Reverse current occurs in two conditions: short to supply and reverse polarity.

- When a short to the supply occurs, there is only reverse current through the body diode. $I_{R(1)}$ specifies the limit of the reverse current.
- In a reverse-polarity condition, there are reverse currents through the body diode and the device GND pin. $I_{R(2)}$ specifies the limit of the reverse current.

To protect the device, TI recommends using two types of external circuitry.

- Adding a blocking diode (method 1). The device and load are protected when in reverse polarity.
- Adding a GND network (method 2). The reverse current through the device GND is blocked. The reverse current through the FET is limited by the load itself. TI recommends a resistor in parallel with the diode as a GND network. The recommended configuration is a 1-kΩ resistor in parallel with a diode that is less than 100 mA.

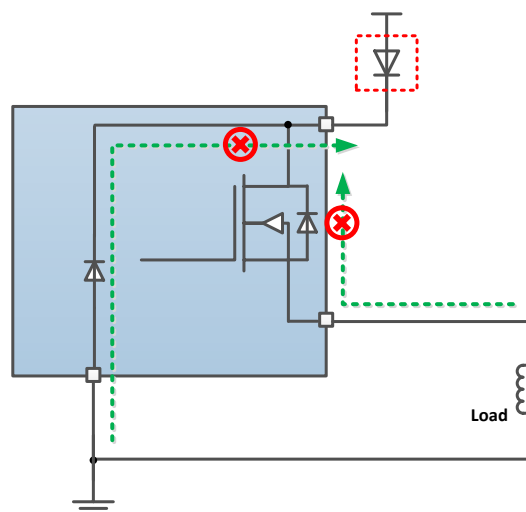

Figure 7-17. Reverse-Current External Protection Method 1

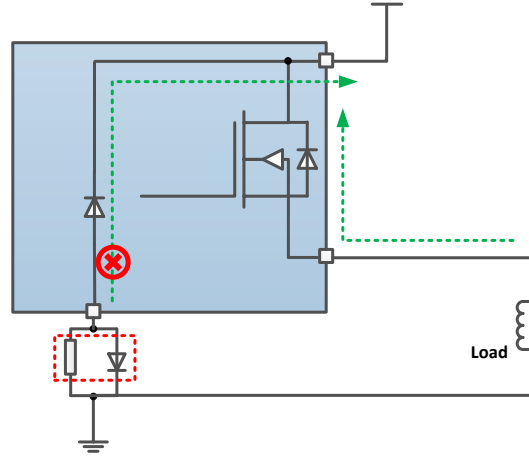

Figure 7-18. Reverse-Current External Protection Method 2

7.3.6.6 MCU I/O Protection

TI recommends using series resistors to protect the microcontroller, for example, 4.7 kΩ when using a 3.3-V microcontroller and 10 kΩ for a 5-V microcontroller.

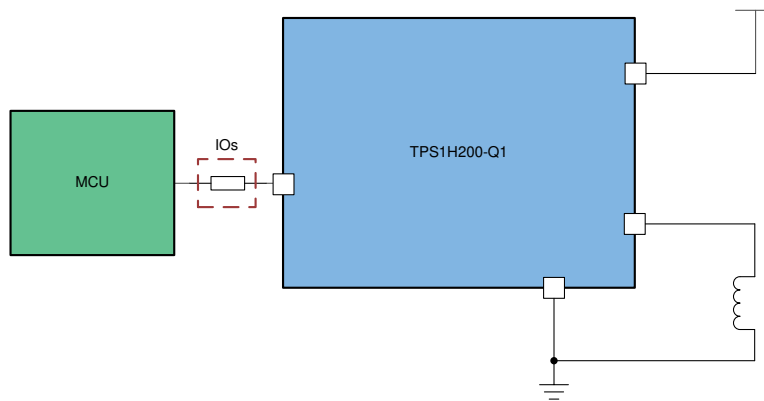

Figure 7-19. MCU I/O External Protection

7.4 Device Functional Modes

7.4.1 Working Modes

The device has three working modes: the normal mode, the standby mode, and the standby mode with diagnostics, as shown in Figure 7-20.

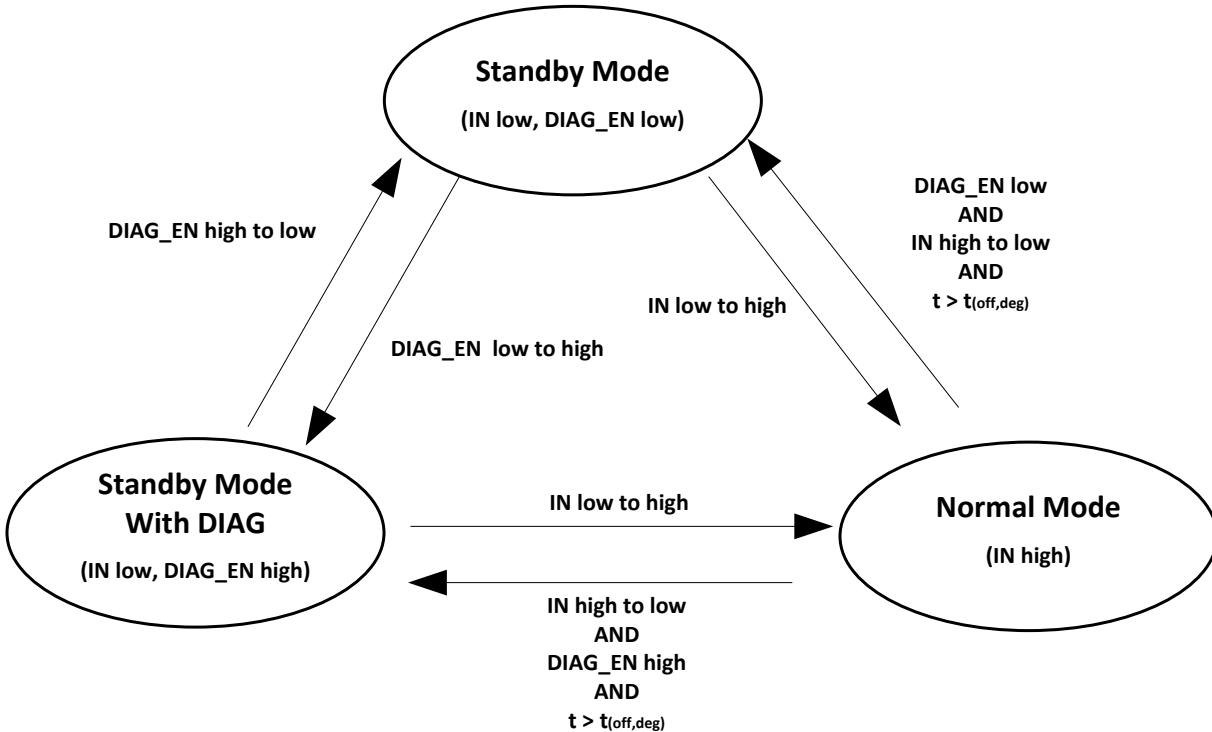

Figure 7-20. Working Modes

7.4.1.1 Normal Mode

When IN is high, the device enters normal mode.

7.4.1.2 Standby Mode

When IN is low and DIAG_EN is low, the device enters standby mode with ultra-low power consumption.

7.4.1.3 Standby Mode With Diagnostics

When IN is low and DIAG_EN is high, the device enters standby mode with diagnostics. The device still supports open-load and short-to-battery detection even when IN is low.

8 Application and Implementation

Note

Information in the following applications sections is not part of the TI component specification, and TI does not warrant its accuracy or completeness. TI's customers are responsible for determining suitability of components for their purposes, as well as validating and testing their design implementation to confirm system functionality.

8.1 Application Information

The TPS1H200A-Q1 device is a smart high-side switch, with an internal charge pump and single-channel integrated NMOS power FET. The adjustable current limit function greatly improves the reliability of the whole system. Full diagnostic features enable intelligent control of the load. The TPS1H200A-Q1 device applies for a wide variety of resistive, inductive, and capacitive loads, including LEDs, relays, and submodules.

8.2 Typical Application

Figure 8-1 shows an example of how to design the external circuitry parameters.

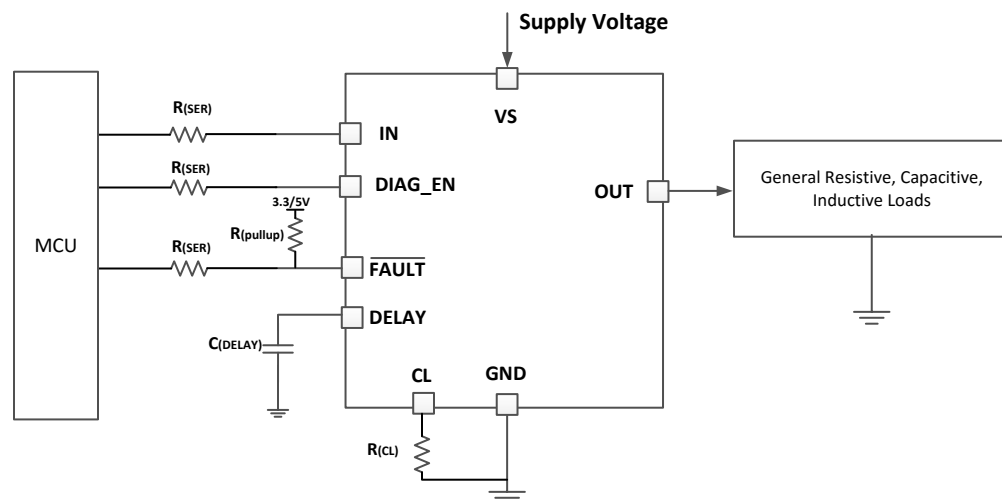

Figure 8-1. Typical Application Circuitry

8.2.1 Design Requirements

- V_{VS} range from 6 V to 18 V
- Nominal current of 500 mA
- Expected current limit value of 2 A
- Thermal sensitive system. When current limit occurs, the output latches off after 0.2 seconds. The 0.2 seconds is to ensure the safe start-up for a capacitive load, clamping the inrush current but without latch-off during start-up.
- Full diagnostics with 5-V MCU, including ON state open-load detection, short-to-GND, or overcurrent detection, and thermal shutdown detection

8.2.2 Detailed Design Procedure

To set the adjustable current limit value at 2 A, calculate $R_{(CL)}$ as follows:

$$R_{(CL)} = \frac{V_{CL(th)} \times K_{(CL)}}{I_{OUT}} = \frac{0.8 \times 2500}{2} = 1000 \Omega \quad (3)$$

To set the adjustable latch-off delay at 0.2 s, calculate $C_{(DELAY)}$ as follows:

$$t_{dl} = t_{CL(deg)} + t_{dl1} + t_{dl2} = 0.2 \gg t_{dl2}$$

$$C_{DELAY} = \frac{I_{dl(chg)} \times t_{dl2}}{V_{dl(ref)}} = \frac{4.5 \times 0.2}{1.45} \times 10^{-6} = 0.62 \mu F \quad (4)$$

TI recommends $R_{(SER)} = 10 \text{ k}\Omega$ for a 5-V MCU, and $R_{(pullup)} = 10 \text{ k}\Omega$ as the pullup resistor.

8.2.3 Application Curves

The following curves are test examples of hard-short conditions. The load is 0.1 A and the current limit value is 0.6 A. [Figure 8-2](#) shows a waveform of the latch-off mode. [Figure 8-3](#) shows a waveform of the auto-retry mode.

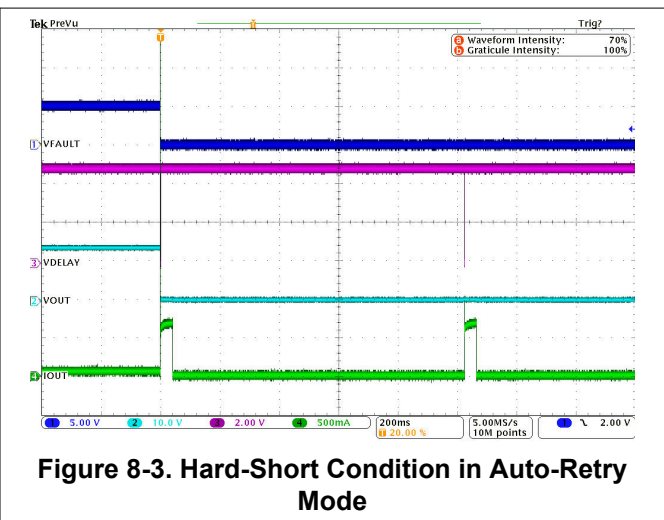
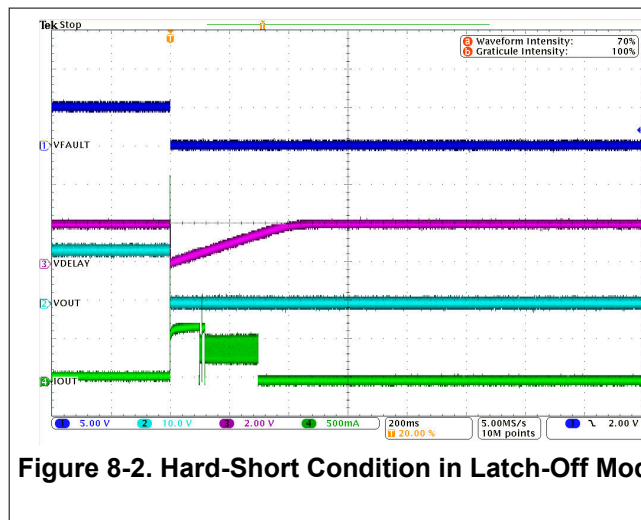

9 Power Supply Recommendations

The device applies to 12-V and 24-V applications. The normal power supply connection is a 12-V or 24-V system.

10 Layout

10.1 Layout Guidelines

To prevent thermal shutdown, T_J must be less than 175°C. If the output current is high, the power dissipation can be large. However, the PCB layout is very important. A good PCB design optimizes heat transfer, which is essential for the long-term reliability of the device.

- Maximize the copper coverage on the PCB to increase the thermal conductivity of the board. The major heat-flow path from the package to the ambient is through the copper on the PCB. Maximum copper is extremely important when no heat sinks are attached to the PCB on the other side of the board opposite the package.
- Add as many thermal vias as possible directly under the package ground pad to optimize the thermal conductivity of the board.
- All thermal vias must either be plated shut or plugged and capped on both sides of the board to prevent solder voids. To ensure reliability and performance, the solder coverage must be at least 85%.

10.2 Layout Example

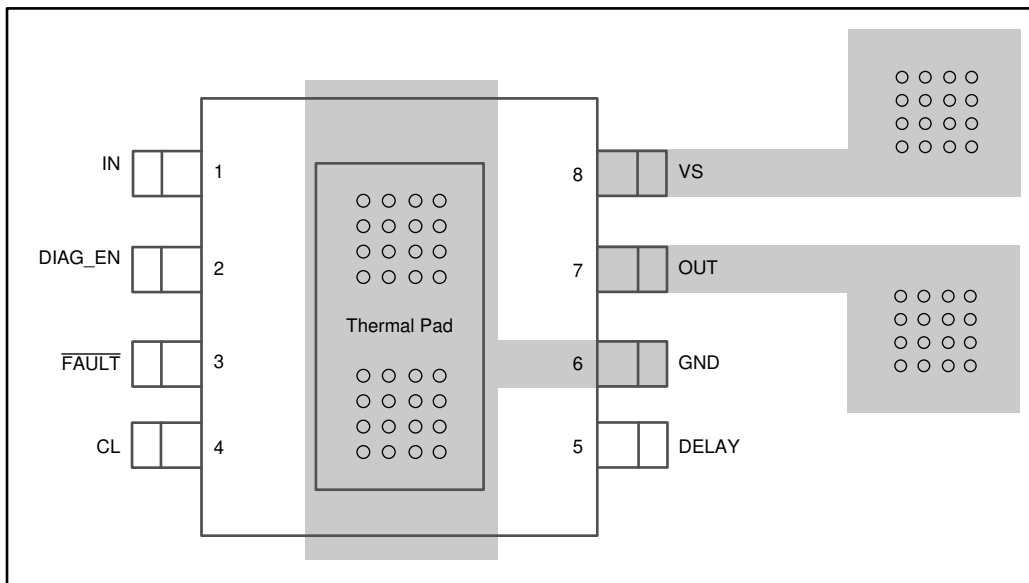

Figure 10-1. Layout Example

11 Device and Documentation Support

11.1 Documentation Support

11.1.1 Related Documentation

For related documentation see the following:

- Texas Instruments, [TPS1H000-Q1 Evaluation Module \(EVM\) User's Guide](#)

11.2 Receiving Notification of Documentation Updates

To receive notification of documentation updates, navigate to the device product folder on [ti.com](#). Click on *Subscribe to updates* to register and receive a weekly digest of any product information that has changed. For change details, review the revision history included in any revised document.

11.3 Support Resources

[TI E2E™ support forums](#) are an engineer's go-to source for fast, verified answers and design help — straight from the experts. Search existing answers or ask your own question to get the quick design help you need.

Linked content is provided "AS IS" by the respective contributors. They do not constitute TI specifications and do not necessarily reflect TI's views; see TI's [Terms of Use](#).

11.4 Trademarks

PowerPAD™ and TI E2E™ are trademarks of Texas Instruments.
All trademarks are the property of their respective owners.

11.5 Electrostatic Discharge Caution



This integrated circuit can be damaged by ESD. Texas Instruments recommends that all integrated circuits be handled with appropriate precautions. Failure to observe proper handling and installation procedures can cause damage.

ESD damage can range from subtle performance degradation to complete device failure. Precision integrated circuits may be more susceptible to damage because very small parametric changes could cause the device not to meet its published specifications.

11.6 Glossary

[TI Glossary](#) This glossary lists and explains terms, acronyms, and definitions.

12 Mechanical, Packaging, and Orderable Information

The following pages include mechanical, packaging, and orderable information. This information is the most current data available for the designated devices. This data is subject to change without notice and revision of this document. For browser-based versions of this data sheet, refer to the left-hand navigation.

PACKAGING INFORMATION

Orderable Device	Status (1)	Package Type	Package Drawing	Pins	Package Qty	Eco Plan (2)	Lead finish/ Ball material (6)	MSL Peak Temp (3)	Op Temp (°C)	Device Marking (4/5)	Samples
TPS1H200AQDGNRQ1	ACTIVE	HVSSOP	DGN	8	2500	RoHS & Green	NIPDAUAG	Level-2-260C-1 YEAR	-40 to 125	1EWX	Samples

(1) The marketing status values are defined as follows:

ACTIVE: Product device recommended for new designs.

LIFEBUY: TI has announced that the device will be discontinued, and a lifetime-buy period is in effect.

NRND: Not recommended for new designs. Device is in production to support existing customers, but TI does not recommend using this part in a new design.

PREVIEW: Device has been announced but is not in production. Samples may or may not be available.

OBSOLETE: TI has discontinued the production of the device.

(2) **RoHS:** TI defines "RoHS" to mean semiconductor products that are compliant with the current EU RoHS requirements for all 10 RoHS substances, including the requirement that RoHS substance do not exceed 0.1% by weight in homogeneous materials. Where designed to be soldered at high temperatures, "RoHS" products are suitable for use in specified lead-free processes. TI may reference these types of products as "Pb-Free".

RoHS Exempt: TI defines "RoHS Exempt" to mean products that contain lead but are compliant with EU RoHS pursuant to a specific EU RoHS exemption.

Green: TI defines "Green" to mean the content of Chlorine (Cl) and Bromine (Br) based flame retardants meet JS709B low halogen requirements of <=1000ppm threshold. Antimony trioxide based flame retardants must also meet the <=1000ppm threshold requirement.

(3) MSL, Peak Temp. - The Moisture Sensitivity Level rating according to the JEDEC industry standard classifications, and peak solder temperature.

(4) There may be additional marking, which relates to the logo, the lot trace code information, or the environmental category on the device.

(5) Multiple Device Markings will be inside parentheses. Only one Device Marking contained in parentheses and separated by a "-" will appear on a device. If a line is indented then it is a continuation of the previous line and the two combined represent the entire Device Marking for that device.

(6) Lead finish/Ball material - Orderable Devices may have multiple material finish options. Finish options are separated by a vertical ruled line. Lead finish/Ball material values may wrap to two lines if the finish value exceeds the maximum column width.

Important Information and Disclaimer:The information provided on this page represents TI's knowledge and belief as of the date that it is provided. TI bases its knowledge and belief on information provided by third parties, and makes no representation or warranty as to the accuracy of such information. Efforts are underway to better integrate information from third parties. TI has taken and continues to take reasonable steps to provide representative and accurate information but may not have conducted destructive testing or chemical analysis on incoming materials and chemicals. TI and TI suppliers consider certain information to be proprietary, and thus CAS numbers and other limited information may not be available for release.

In no event shall TI's liability arising out of such information exceed the total purchase price of the TI part(s) at issue in this document sold by TI to Customer on an annual basis.

TAPE AND REEL INFORMATION

QUADRANT ASSIGNMENTS FOR PIN 1 ORIENTATION IN TAPE

*All dimensions are nominal

Device	Package Type	Package Drawing	Pins	SPQ	Reel Diameter (mm)	Reel Width W1 (mm)	A0 (mm)	B0 (mm)	K0 (mm)	P1 (mm)	W (mm)	Pin1 Quadrant
TPS1H200AQDGNRQ1	HVSSOP	DGN	8	2500	330.0	12.4	5.3	3.4	1.4	8.0	12.0	Q1

TAPE AND REEL BOX DIMENSIONS



*All dimensions are nominal

Device	Package Type	Package Drawing	Pins	SPQ	Length (mm)	Width (mm)	Height (mm)
TPS1H200AQDGNRQ1	HVSSOP	DGN	8	2500	366.0	364.0	50.0

GENERIC PACKAGE VIEW

DGN 8

PowerPAD VSSOP - 1.1 mm max height

3 x 3, 0.65 mm pitch

SMALL OUTLINE PACKAGE

This image is a representation of the package family, actual package may vary.
Refer to the product data sheet for package details.



4225482/A

DGN0008G



PACKAGE OUTLINE

PowerPAD™ VSSOP - 1.1 mm max height

SMALL OUTLINE PACKAGE

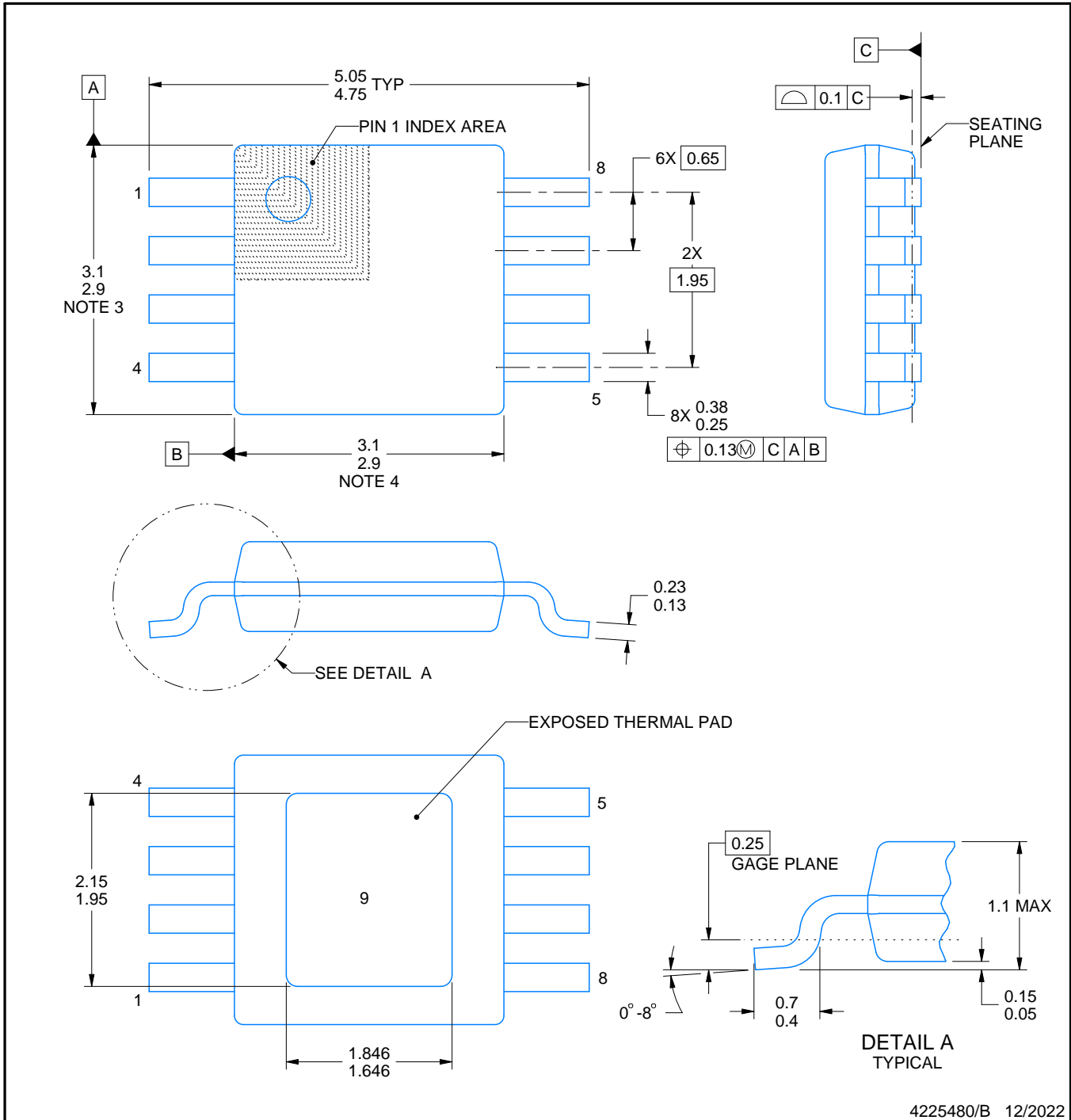

NOTES:

PowerPAD is a trademark of Texas Instruments.

1. All linear dimensions are in millimeters. Any dimensions in parenthesis are for reference only. Dimensioning and tolerancing per ASME Y14.5M.
2. This drawing is subject to change without notice.
3. This dimension does not include mold flash, protrusions, or gate burrs. Mold flash, protrusions, or gate burrs shall not exceed 0.15 mm per side.
4. This dimension does not include interlead flash. Interlead flash shall not exceed 0.25 mm per side.
5. Reference JEDEC registration MO-187.

EXAMPLE BOARD LAYOUT

DGN0008G

PowerPAD™ VSSOP - 1.1 mm max height

SMALL OUTLINE PACKAGE



LAND PATTERN EXAMPLE
EXPOSED METAL SHOWN
SCALE: 15X



SOLDER MASK DETAILS

4225480/B 12/2022

NOTES: (continued)

6. Publication IPC-7351 may have alternate designs.
7. Solder mask tolerances between and around signal pads can vary based on board fabrication site.
8. Vias are optional depending on application, refer to device data sheet. If any vias are implemented, refer to their locations shown on this view. It is recommended that vias under paste be filled, plugged or tented.
9. Size of metal pad may vary due to creepage requirement.

EXAMPLE STENCIL DESIGN

DGN0008G

PowerPAD™ VSSOP - 1.1 mm max height

SMALL OUTLINE PACKAGE

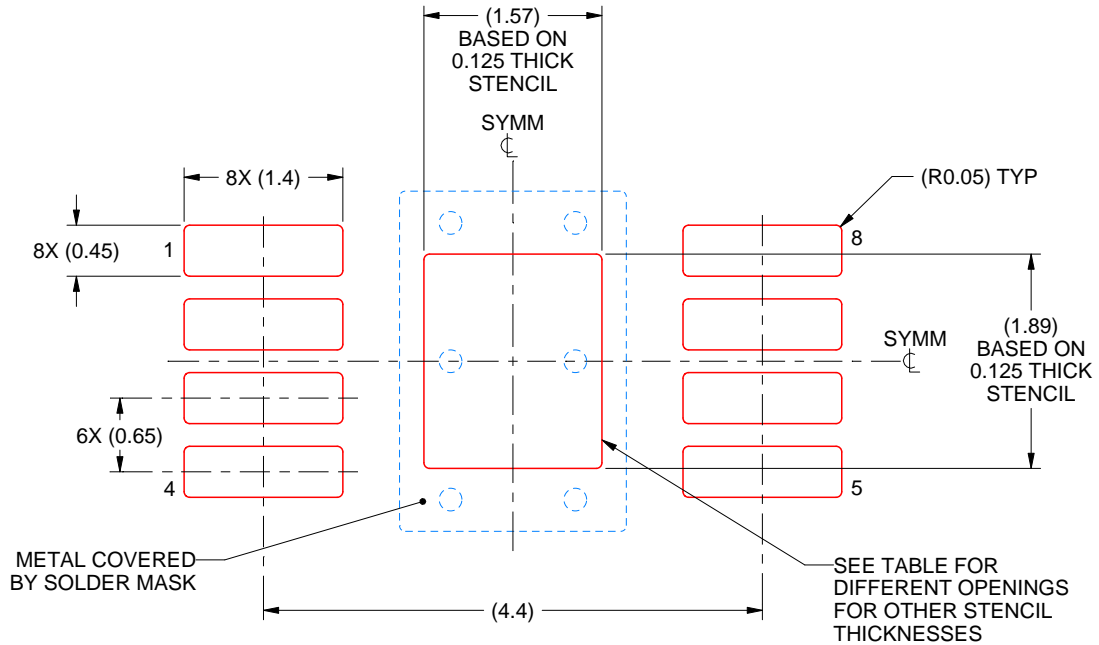

SOLDER PASTE EXAMPLE
EXPOSED PAD 9:
100% PRINTED SOLDER COVERAGE BY AREA
SCALE: 15X

STENCIL THICKNESS	SOLDER STENCIL OPENING
0.1	1.76 X 2.11
0.125	1.57 X 1.89 (SHOWN)
0.15	1.43 X 1.73
0.175	1.33 X 1.60

4225480/B 12/2022

NOTES: (continued)

10. Laser cutting apertures with trapezoidal walls and rounded corners may offer better paste release. IPC-7525 may have alternate design recommendations.
11. Board assembly site may have different recommendations for stencil design.

IMPORTANT NOTICE AND DISCLAIMER

TI PROVIDES TECHNICAL AND RELIABILITY DATA (INCLUDING DATA SHEETS), DESIGN RESOURCES (INCLUDING REFERENCE DESIGNS), APPLICATION OR OTHER DESIGN ADVICE, WEB TOOLS, SAFETY INFORMATION, AND OTHER RESOURCES "AS IS" AND WITH ALL FAULTS, AND DISCLAIMS ALL WARRANTIES, EXPRESS AND IMPLIED, INCLUDING WITHOUT LIMITATION ANY IMPLIED WARRANTIES OF MERCHANTABILITY, FITNESS FOR A PARTICULAR PURPOSE OR NON-INFRINGEMENT OF THIRD PARTY INTELLECTUAL PROPERTY RIGHTS.

These resources are intended for skilled developers designing with TI products. You are solely responsible for (1) selecting the appropriate TI products for your application, (2) designing, validating and testing your application, and (3) ensuring your application meets applicable standards, and any other safety, security, regulatory or other requirements.

These resources are subject to change without notice. TI grants you permission to use these resources only for development of an application that uses the TI products described in the resource. Other reproduction and display of these resources is prohibited. No license is granted to any other TI intellectual property right or to any third party intellectual property right. TI disclaims responsibility for, and you will fully indemnify TI and its representatives against, any claims, damages, costs, losses, and liabilities arising out of your use of these resources.

TI's products are provided subject to [TI's Terms of Sale](#) or other applicable terms available either on ti.com or provided in conjunction with such TI products. TI's provision of these resources does not expand or otherwise alter TI's applicable warranties or warranty disclaimers for TI products.

TI objects to and rejects any additional or different terms you may have proposed.

Mailing Address: Texas Instruments, Post Office Box 655303, Dallas, Texas 75265
Copyright © 2022, Texas Instruments Incorporated

单击下面可查看定价，库存，交付和生命周期等信息

[>>TI\(德州仪器\)](#)