

LM3150 Wide-VIN Synchronous Buck Controller

1 Features

- PowerWise™ Step-Down Controller
- 6-V to 42-V Wide Input Voltage Range
- Adjustable Output Voltage Down to 0.6 V
- Programmable Switching Frequency up to 1 MHz
- No Loop Compensation Required
- Fully WEBENCH® Enabled
- Low External Component Count
- Constant On-Time (COT) Control
- Ultra-Fast Transient Response
- Stable With Low ESR Capacitors
- Output Voltage PreBias Startup
- Valley Current Limit
- Programmable Soft-Start
- Create a Custom Design Using the LM3150 with the [WEBENCH Power Designer](#)

2 Applications

- Telecom
- Networking Equipment
- Routers
- Security Surveillance
- Power Modules

3 Description

The LM3150 SIMPLE SWITCHER® controller is an easy-to-use and simplified step-down power controller capable of providing up to 12 A of output current in a typical application. Operating with an input voltage range of 6 V to 42 V, the LM3150 controller features an adjustable output voltage down to 0.6 V. The switching frequency is adjustable up to 1 MHz and the synchronous architecture provides for highly efficient designs. The LM3150 controller employs a constant on-time (COT) architecture with a proprietary emulated ripple mode (ERM) control that allows for the use of low ESR output capacitors, which reduces overall solution size and output voltage ripple. The COT regulation architecture allows for fast transient response and requires no loop compensation, which reduces external component count and reduces design complexity.

Fault protection features such as thermal shutdown, undervoltage lockout, overvoltage protection, short-circuit protection, current limit, and output voltage prebias start-up allow for a reliable and robust solution.

The LM3150 concept provides for an easy-to-use complete design using a minimum number of external components and TI's WEBENCH online design tool. WEBENCH provides design support for every step of the design process and includes features such as external component calculation with a new MOSFET selector, electrical simulation, thermal simulation, and Build-It boards for prototyping.

Device Information⁽¹⁾

PART NUMBER	PACKAGE	BODY SIZE (NOM)
LM3150	HTSSOP (14)	5.00 mm x 4.40 mm

(1) For all available packages, see the orderable addendum at the end of the datasheet.

4 Typical Application Schematic

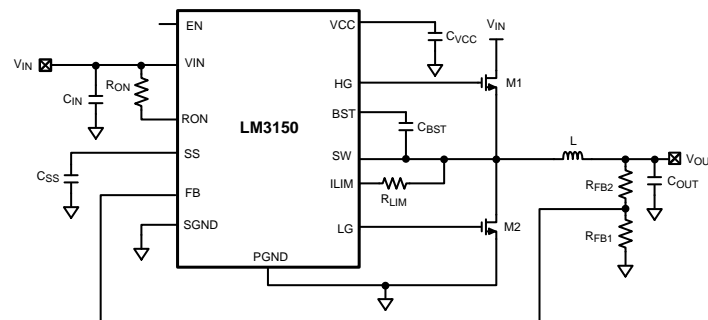

Table of Contents

1 Features	1	8.3 Feature Description	10
2 Applications	1	8.4 Device Functional Modes	13
3 Description	1	9 Application and Implementation	14
4 Typical Application Schematic	1	9.1 Application Information	14
5 Revision History	2	9.2 Typical Application	14
6 Pin Configuration and Functions	3	10 Power Supply Recommendations	25
7 Specifications	4	11 Layout	25
7.1 Absolute Maximum Ratings	4	11.1 Layout Guidelines	25
7.2 ESD Ratings	4	11.2 Layout Example	26
7.3 Recommended Operating Ratings	4	12 Device and Documentation Support	27
7.4 Thermal Information	4	12.1 Documentation Support	27
7.5 Electrical Characteristics	5	12.2 Community Resources	27
7.6 Typical Characteristics	7	12.3 Trademarks	27
8 Detailed Description	9	12.4 Electrostatic Discharge Caution	27
8.1 Overview	9	12.5 Glossary	28
8.2 Functional Block Diagram	10	13 Mechanical, Packaging, and Orderable Information	28

5 Revision History

Changes from Revision F (December 2014) to Revision G Page

- Changed graphic Inductor Current to Current Limit section. **11**

Changes from Revision E (November 2012) to Revision F Page

- Added *ESD Ratings* table, *Feature Description* section, *Device Functional Modes*, *Application and Implementation* section, *Power Supply Recommendations* section, *Layout* section, *Device and Documentation Support* section, and *Mechanical, Packaging, and Orderable Information* section **4**

6 Pin Configuration and Functions

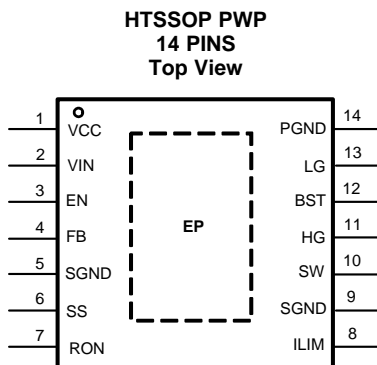

Pin Functions

PIN		I/O	DESCRIPTION	FUNCTION
NAME	NO.			
VCC	1	O	Supply Voltage for FET Drivers	Nominally regulated to 5.95 V. Connect a 1.0- μ F to 4.7- μ F decoupling capacitor from this pin to ground.
VIN	2	I	Input Supply Voltage	Supply pin to the device. Nominal input range is 6 V to 42 V.
EN	3	I	Enable	To enable the IC, apply a logic high signal to this pin greater than 1.26-V typical or leave floating. To disable the part, ground the EN pin.
FB	4	I	Feedback	Internally connected to the regulation, overvoltage, and short-circuit comparators. The regulation setting is 0.6 V at this pin. Connect to feedback resistor divider between the output and ground to set the output voltage.
SGND	5,9	—	Signal Ground	Ground for all internal bias and reference circuitry. Should be connected to PGND at a single point.
SS	6	I	Soft-Start	An internal 7.7- μ A current source charges an external capacitor to provide the soft-start function.
RON	7	I	On-time Control	An external resistor from VIN to this pin sets the high-side switch on-time.
ILIM	8	I	Current Limit	Monitors current through the low-side switch and triggers current limit operation if the inductor valley current exceeds a user defined value that is set by R_{LIM} and the Sense current, I_{LIM-TH} , sourced out of this pin during operation.
SW	10	O	Switch Node	Switch pin of controller and high-gate driver lower supply rail. A boost capacitor is also connected between this pin and BST pin
HG	11	O	High-Side Gate Drive	Gate drive signal to the high-side NMOS switch. The high-side gate driver voltage is supplied by the differential voltage between the BST pin and SW pin.
BST	12	I	Connection for Bootstrap Capacitor	High-gate driver upper supply rail. Connect a 0.33 to 0.47- μ F capacitor from SW pin to this pin. An internal diode charges the capacitor during the high-side switch off-time. Do not connect to an external supply rail.
LG	13	O	Low-Side Gate Drive	Gate drive signal to the low-side NMOS switch. The low-side gate driver voltage is supplied by VCC.
PGND	14	G	Power Ground	Synchronous rectifier MOSFET source connection. Tie to power ground plane. Should be tied to SGND at a single point.
EP	—	—	Exposed Pad	Exposed die attach pad should be connected directly to SGND. Also used to help dissipate heat out of the IC.

7 Specifications

7.1 Absolute Maximum Ratings

over operating free-air temperature range (unless otherwise noted) ⁽¹⁾⁽²⁾

	MIN	MAX	UNIT
V _{IN} , RON to GND	-0.3	47	V
SW to GND	-3	47	V
BST to SW	-0.3	7	V
BST to GND	-0.3	52	V
All Other Inputs to GND	-0.3	7	V
T _{stg} Storage temperature	-65	150	°C

- Stresses beyond those listed under *Absolute Maximum Ratings* may cause permanent damage to the device. These are stress ratings only, which do not imply functional operation of the device at these or any other conditions beyond those indicated under *Recommended Operating Ratings*. Exposure to absolute-maximum-rated conditions for extended periods may affect device reliability.
- If Military/Aerospace specified devices are required, please contact the Texas Instruments Sales Office/ Distributors for availability and specifications.

7.2 ESD Ratings

	VALUE	UNIT
V _(ESD) Electrostatic discharge Human body model (HBM), per ANSI/ESDA/JEDEC JS-001, all pins ⁽¹⁾	±2000	V

- JEDEC document JEP155 states that 500-V HBM allows safe manufacturing with a standard ESD control process.

7.3 Recommended Operating Ratings

over operating free-air temperature range (unless otherwise noted)

	MIN	NOM	MAX	UNIT
V _{IN}	6		42	V
Junction Temperature Range (T _J)	-40		125	°C
EN	0		5	V

7.4 Thermal Information

THERMAL METRIC ⁽¹⁾	LM3150	UNIT
	PWP	
	14 PINS	
R _{θJA} Junction-to-ambient thermal resistance	42.5	°C/W
R _{θJC(top)} Junction-to-case (top) thermal resistance	28.7	
R _{θJB} Junction-to-board thermal resistance	24.2	
ψ _{JT} Junction-to-top characterization parameter	0.9	
ψ _{JB} Junction-to-board characterization parameter	23.9	
R _{θJC(bot)} Junction-to-case (bottom) thermal resistance	4.4	

- For more information about traditional and new thermal metrics, see the *IC Package Thermal Metrics* application report, [SPRA953](#).

7.5 Electrical Characteristics

over operating free-air temperature range (unless otherwise noted)

PARAMETER		TEST CONDITIONS	T _J = 25°C			T _J = -40°C to 125°C			UNIT
			MIN	TYP	MAX	MIN	TYP	MAX	
START-UP; REGULATOR, VCC									
VCC		C _{VCC} = 1 μF, 0 mA to 40 mA	5.95			5.65	6.25	V	
VIN - VCC	VIN - VCC Dropout Voltage	I _{VCC} = 2 mA, V _{IN} = 5.5 V	40						mV
		I _{VCC} = 30 mA, V _{IN} = 5.5 V	330						
I _{VCC} L	VCC Current Limit ⁽¹⁾	VCC = 0V	100			65			mA
VCC _{UVLO}	VCC Undervoltage Lockout Threshold (UVLO)	VCC Increasing	5.1			4.75	5.40	V	
VCC _{UVLO-HYS}	VCC UVLO Hysteresis	VCC Decreasing	475						mV
t _{CC-UVLO-D}	VCC UVLO Filter Delay		3						μs
I _{IN}	Input Operating Current	No Switching, V _{FB} = 1 V	3.5			5			mA
I _{IN-SD}	Input Operating Current, Device Shutdown	V _{EN} = 0 V	32			55			μA
GATE DRIVE									
I _{Q-BST}	Boost Pin Leakage	V _{BST} - V _{SW} = 6 V	2						nA
R _{DS-HG-Pull-Up}	HG Drive Pullup On-Resistance	I _{HG} Source = 200 mA	5						Ω
R _{DS-HG-Pull-Down}	HG Drive Pulldown On-Resistance	I _{HG} Sink = 200 mA	3.4						Ω
R _{DS-LG-Pull-Up}	LG Drive Pullup On-Resistance	I _{LG} Source = 200 mA	3.4						Ω
R _{DS-LG-Pull-Down}	LG Drive Pulldown On-Resistance	I _{LG} Sink = 200 mA	2						Ω
SOFT-START									
I _{SS}	SS Pin Source Current	V _{SS} = 0 V	7.7			5.9	9.5	μA	
I _{SS-DIS}	SS Pin Discharge Current	Current Limit	200						μA
I _{LIM-TH}	Current Limit Sense Pin Source Current		75	85	95				μA
ON/OFF TIMER									
t _{ON}	ON Timer Pulse Width	V _{IN} = 10V, R _{ON} = 100 kΩ, V _{FB} = 0.6V	1.02						μs
		V _{IN} = 18V, R _{ON} = 100 kΩ, V _{FB} = 0.6 V	0.62						
		V _{IN} = 42 V, R _{ON} = 100 kΩ, V _{FB} = 0.6 V	0.36						
t _{ON-MIN}	ON Timer Minimum Pulse Width	See ⁽²⁾	200						ns
t _{OFF}	OFF Timer Minimum Pulse Width		370			525			ns
ENABLE INPUT									
V _{EN}	EN Pin Input Threshold Trip Point	V _{EN} Rising	1.20			1.14	1.26	V	
V _{EN-HYS}	EN Pin Threshold Hysteresis	V _{EN} Falling	120						mV
REGULATION AND OVERVOLTAGE COMPARATOR									
V _{FB}	In-Regulation Feedback Voltage	V _{SS} > 0.6 V	0.600			0.588	0.612	V	
V _{FB-OV}	Feedback Overvoltage Threshold		0.720			0.690	0.748	V	
I _{FB}	Feedback Bias Current		20						nA

(1) VCC provides self bias for the internal gate drive and control circuits. Device thermal limitations limit external loading.

(2) See [Detailed Description](#) section for minimum on-time when using MOSFETs connected to gate drivers.

Electrical Characteristics (continued)

over operating free-air temperature range (unless otherwise noted)

PARAMETER		TEST CONDITIONS	T _J = 25°C			T _J = -40°C to 125°C			UNIT
			MIN	TYP	MAX	MIN	TYP	MAX	
BOOST DIODE									
V _f	Forward Voltage	I _{BST} = 2 mA	0.7						V
		I _{BST} = 30 mA	1						
THERMAL CHARACTERISTICS									
T _{SD}	Thermal Shutdown	Rising	165						°C
	Thermal Shutdown Hysteresis	Falling	15						°C

7.6 Typical Characteristics

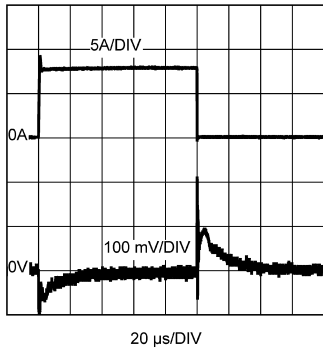

Figure 1. 500-kHz Full Load Transient

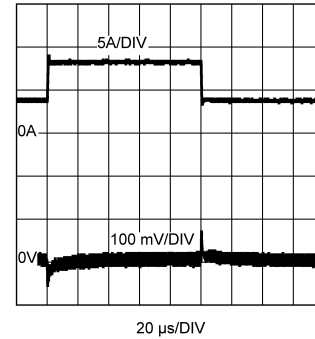

Figure 2. 500-kHz Partial Load Transient

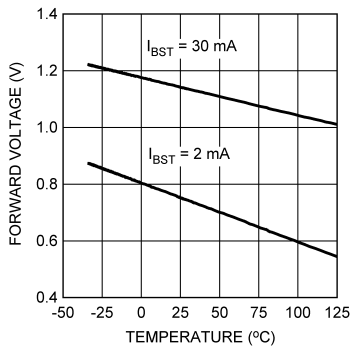

Figure 3. Boost Diode Forward Voltage vs Temperature

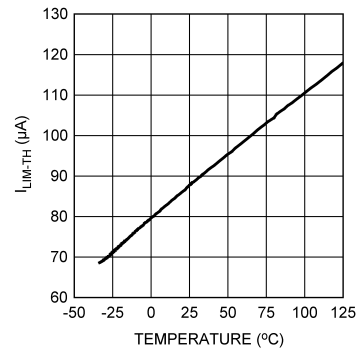

Figure 4. I_{LIM-TH} vs Temperature

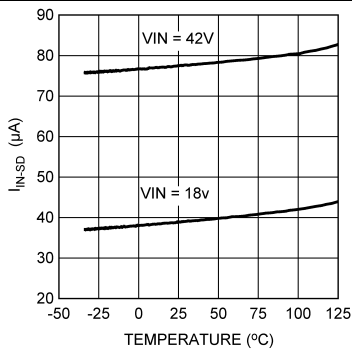

Figure 5. Quiescent Current vs Temperature

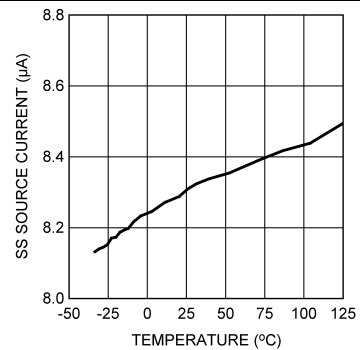

Figure 6. Soft-Start Current vs Temperature

Typical Characteristics (continued)

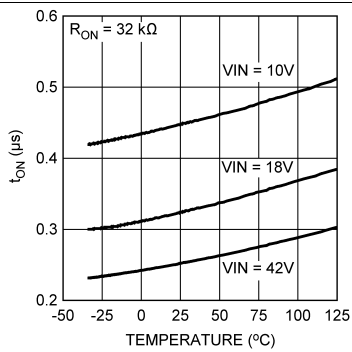

Figure 7. t_{ON} vs Temperature

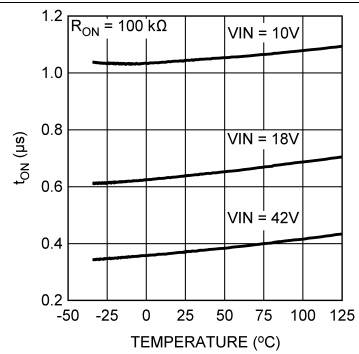

Figure 8. t_{ON} vs Temperature

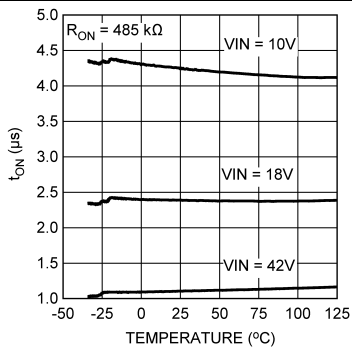

Figure 9. t_{ON} vs Temperature

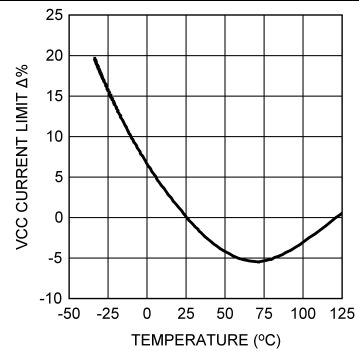

Figure 10. VCC Current Limit vs Temperature

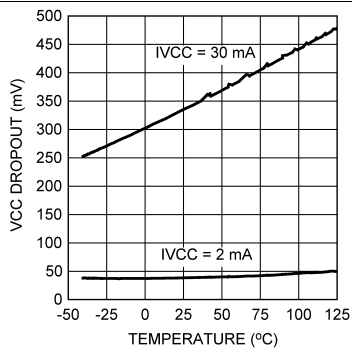

Figure 11. VCC Dropout vs Temperature

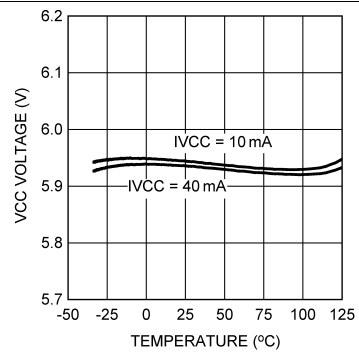

Figure 12. VCC vs Temperature

8 Detailed Description

8.1 Overview

The LM3150 synchronous step-down controller uses a COT architecture which is a derivative of the hysteretic control scheme. COT relies on a fixed switch on-time to regulate the output. The on-time of the high-side switch can be set manually by adjusting the size of an external resistor (R_{ON}). To maintain a relatively constant switching frequency as V_{IN} varies, the LM3150 controller automatically adjusts the on-time inversely with the input voltage. Assuming an ideal system and V_{IN} is much greater than 1 V, the following approximations can be made:

The on-time, t_{ON} :

$$t_{ON} = \frac{K \times R_{ON}}{V_{IN}}$$

where

- constant $K = 100 \text{ pC}$ (1)

The R_{ON} resistance value can be calculated as follows:

$$R_{ON} = \frac{V_{OUT}}{K \times f_s}$$

where

- f_s is the desired switching frequency (2)

Control is based on a comparator and the on-timer, with the output voltage feedback (FB) compared with an internal reference of 0.6 V. If the FB level is below the reference, the high-side switch is turned on for a fixed time, t_{ON} , which is determined by the input voltage and the resistor R_{ON} . Following this on-time, the switch remains off for a minimum off-time, t_{OFF} , as specified in the [Electrical Characteristics](#) table or until the FB pin voltage is below the reference, then the switch turns on again for another on-time period. The switching will continue in this fashion to maintain regulation. During continuous conduction mode (CCM), the switching frequency ideally depends on duty-cycle and on-time only. In a practical application however, there is a small delay in the time that the HG goes low and the SW node goes low that also affects the switching frequency that is accounted for in the typical application curves. The duty-cycle and frequency can be approximated as:

$$D = \frac{t_{ON}}{t_{ON} + t_{OFF}} = t_{ON} \times f_s \approx \frac{V_{OUT}}{V_{IN}} \quad (3)$$

$$f_s = \frac{V_{OUT}}{K \times R_{ON}} \quad (4)$$

Typical COT hysteretic controllers need a significant amount of output capacitor ESR to maintain a minimum amount of ripple at the FB pin in order to switch properly and maintain efficient regulation. The LM3150 controller, however, uses a proprietary Emulated Ripple Mode control scheme (ERM) that allows the use of low ESR output capacitors. Not only does this reduce the need for high output capacitor ESR, but also significantly reduces the amount of output voltage ripple seen in a typical hysteretic control scheme. The output ripple voltage can become so low that it is comparable to voltage-mode and current-mode control schemes.

8.2 Functional Block Diagram

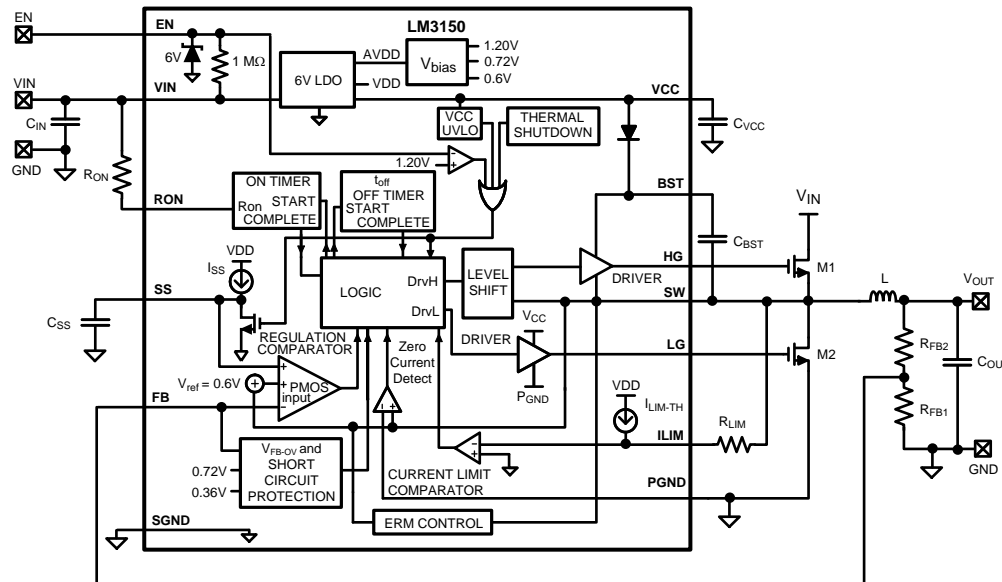

8.3 Feature Description

8.3.1 Programming the Output Voltage

The output voltage is set by two external resistors (R_{FB1} , R_{FB2}). The regulated output voltage is calculated as follows:

$$V_{OUT} = V_{FB} \times \frac{(R_{FB1} + R_{FB2})}{R_{FB1}}$$

where

- R_{FB2} is the top resistor connected between V_{OUT} and FB
- R_{FB1} is the bottom resistor connected between FB and GND

(5)

8.3.2 Regulation Comparator

The feedback voltage at FB is compared to the internal reference voltage of 0.6 V. In normal operation (the output voltage is regulated), an on-time period is initiated when the voltage at FB falls below 0.6 V. The high-side switch stays on for the on-time, causing the FB voltage to rise above 0.6 V. After the on-time period, the high-side switch stays off until the FB voltage falls below 0.6 V.

8.3.3 Overvoltage Comparator

The overvoltage comparator is provided to protect the output from overvoltage conditions due to sudden input line voltage changes or output loading changes. The overvoltage comparator continuously monitors the voltage at the FB pin and compares it to a 0.72 V internal reference. If the voltage at FB rises above 0.72 V, the on-time pulse is immediately terminated. This condition can occur if the input or the output load changes suddenly. Once the overvoltage protection is activated, the HG and LG signals remain off until the voltage at FB pin falls below 0.72 V.

8.3.4 Current Limit

Current limit detection occurs during the off-time by monitoring the current through the low-side switch using an external resistor, R_{LIM} . If during the off-time the current in the low-side switch exceeds the user defined current limit value, the next on-time cycle is immediately terminated. Current sensing is achieved by comparing the voltage across the low side FET with the voltage across the current limit set resistor R_{LIM} . If the voltage across R_{LIM} and the voltage across the low-side FET are equal then the current limit comparator will terminate the next on-time cycle.

Feature Description (continued)

The R_{LIM} value can be approximated as follows:

$$I_{CL} = I_{OCL} - \frac{\Delta I_L}{2} \quad (6)$$

$$R_{LIM} = \frac{I_{CL} \times R_{DS(ON)max}}{I_{LIM-TH}}$$

where

- I_{OCL} is the user-defined average output current limit value
- $R_{DS(ON)max}$ is the resistance value of the low-side FET at the expected maximum FET junction temperature
- I_{LIM-TH} is an internal current supply of 85 μ A typical

Figure 13 illustrates the inductor current waveform. During normal operation, the output current ripple is dictated by the switching of the FETs. The current through the low-side switch, I_{valley} , is sampled at the end of each switching cycle and compared to the current limit, I_{CL} , current. The valley current can be calculated as follows:

$$I_{valley} = I_{OUT} - \frac{\Delta I_L}{2}$$

where

- I_{OUT} is the average output current
- ΔI_L is the peak-to-peak inductor ripple current

If an overload condition occurs, the current through the low-side switch will increase which will cause the current limit comparator to trigger the logic to skip the next on-time cycle. The IC will then try to recover by checking the valley current during each off-time. If the valley current is greater than or equal to I_{CL} , then the IC will keep the low-side FET on and allow the inductor current to further decay.

Throughout the whole process, regardless of the load current, the on-time of the controller will stay constant and thereby the positive ripple current slope will remain constant. During each on-time the current ramps-up an amount equal to:

$$\Delta I_L = \frac{(V_{IN} - V_{OUT}) \times t_{ON}}{L} \quad (9)$$

The valley current limit feature prevents current runaway conditions due to propagation delays or inductor saturation because the inductor current is forced to decay following any overload conditions.

Current sensing is achieved by either a low value sense resistor in series with the low-side FET or by utilizing the $R_{DS(ON)}$ of the low-side FET. The $R_{DS(ON)}$ sensing method is the preferred choice for a more simplified design and lower costs. The $R_{DS(ON)}$ value of a FET has a positive temperature coefficient and will increase in value as the temperature of the FET increases. The LM3150 controller will maintain a more stable current limit that is closer to the original value that was set by the user, by positively adjusting the I_{LIM-TH} value as the IC temperature increases. This does not provide an exact temperature compensation but allows for a more tightly controlled current limit when compared to traditional $R_{DS(ON)}$ sensing methods when the $R_{DS(ON)}$ value can change typically 140% from room to maximum temperature and cause other components to be over-designed. The temperature compensated I_{LIM-TH} is shown below where T_J is the die temperature of the LM3150 controller in Celsius:

$$I_{LIM-TH}(T_J) = I_{LIM-TH} \times [1 + 3.3 \times 10^{-3} \times (T_J - 27)] \quad (10)$$

To calculate the R_{LIM} value with temperature compensation, substitute [Equation 10](#) into I_{LIM-TH} in [Equation 7](#).

Feature Description (continued)

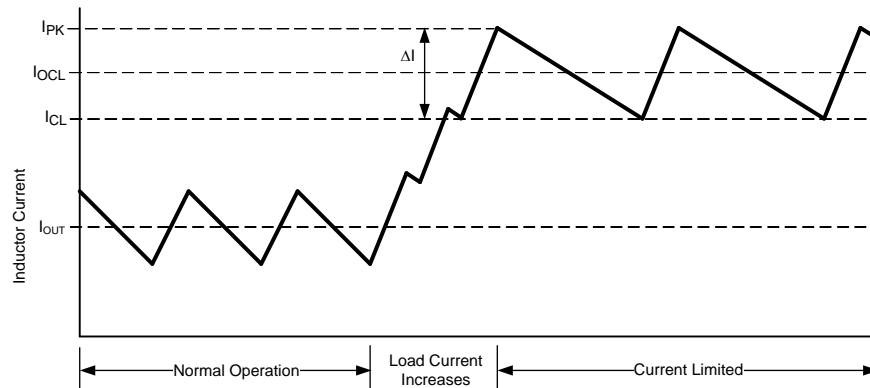

Figure 13. Inductor Current - Current Limit Operation

8.3.5 Short-Circuit Protection

The LM3150 controller will sense a short-circuit on the output by monitoring the output voltage. When the feedback voltage has fallen below 60% of the reference voltage, $V_{ref} \times 0.6$ (≈ 0.36 V), short-circuit mode of operation will start. During short-circuit operation, the SS pin is discharged and the output voltage will fall to 0 V. The SS pin voltage, V_{SS} , is then ramped back up at the rate determined by the SS capacitor and I_{SS} until V_{SS} reaches 0.7 V. During this re-ramp phase, if the short-circuit fault is still present the output current will be equal to the set current limit. Once the soft-start voltage reaches 0.7 V, the output voltage is sensed again and if the V_{FB} is still below $V_{ref} \times 0.6$ then the SS pin is discharged again and the cycle repeats until the short-circuit fault is removed.

8.3.6 Soft-Start

The soft-start (SS) feature allows the regulator to gradually reach a steady-state operating point, which reduces start-up stresses and current surges. At turnon, while VCC is below the undervoltage threshold, the SS pin is internally grounded and V_{OUT} is held at 0 V. The SS capacitor is used to slowly ramp V_{FB} from 0 V to 0.6 V. By changing the capacitor value, the duration of start-up can be changed accordingly. The start-up time can be calculated using the following equation:

$$t_{SS} = \frac{V_{ref} \times C_{SS}}{I_{SS}}$$

where

- t_{SS} is measured in seconds
- $V_{ref} = 0.6$ V
- I_{SS} is the soft-start pin source current, which is typically 7.7 μ A (refer to [Electrical Characteristics](#)) (11)

An internal switch grounds the SS pin if VCC is below the undervoltage lockout threshold, if a thermal shutdown occurs, or if the EN pin is grounded. By using an externally controlled switch, the output voltage can be shut off by grounding the SS pin.

During startup the LM3150 controller will operate in diode emulation mode, where the low-side gate LG will turn off and remain off when the inductor current falls to zero. Diode emulation mode will allow start-up into a pre-biased output voltage. When soft-start is greater than 0.7 V, the LM3150 controller will remain in continuous conduction mode. During diode emulation mode at current limit the low-gate will remain off when the inductor current is off.

The soft-start time should be greater than the input voltage rise time and also satisfy the following equality to maintain a smooth transition of the output voltage to the programmed regulation voltage during start-up.

$$t_{SS} \geq (V_{OUT} \times C_{OUT}) / (I_{OCL} - I_{OUT}) \quad (12)$$

Feature Description (continued)

8.3.7 Thermal Protection

The LM3150 controller should be operated such that the junction temperature does not exceed the maximum operating junction temperature. An internal thermal shutdown circuit, which activates at 165°C (typical), takes the controller to a low-power reset state by disabling the buck switch and the on-timer, and grounding the SS pin. This feature helps prevent catastrophic failures from accidental device overheating. When the junction temperature falls back below 150°C the SS pin is released and device operation resumes.

8.4 Device Functional Modes

The EN pin can be activated by either leaving the pin floating due to an internal pullup resistor to VIN or by applying a logic high signal to the EN pin of 1.26 V or greater. The LM3150 controller can be remotely shut down by taking the EN pin below 1.02 V. Low quiescent shutdown is achieved when VEN is less than 0.4 V. During low quiescent shutdown the internal bias circuitry is turned off.

The LM3150 controller has certain fault conditions that can trigger shutdown, such as short circuit, undervoltage lockout, or thermal shutdown. During shutdown, the soft-start capacitor is discharged. Once the fault condition is removed, the soft-start capacitor begins charging, allowing the part to start-up in a controlled fashion. In conditions where there may be an open drain connection to the EN pin, it may be necessary to add a 1-nF bypass capacitor to this pin. This will help decouple noise from the EN pin and prevent false disabling.

9 Application and Implementation

NOTE

Information in the following applications sections is not part of the TI component specification, and TI does not warrant its accuracy or completeness. TI's customers are responsible for determining suitability of components for their purposes. Customers should validate and test their design implementation to confirm system functionality.

9.1 Application Information

The LM3150 controller employs a COT architecture with ERM (emulated ripple mode) control. This allows for fast transient response, reduction in output voltage ripple, and low external component count. A typical application of this part is described in the following section.

9.2 Typical Application

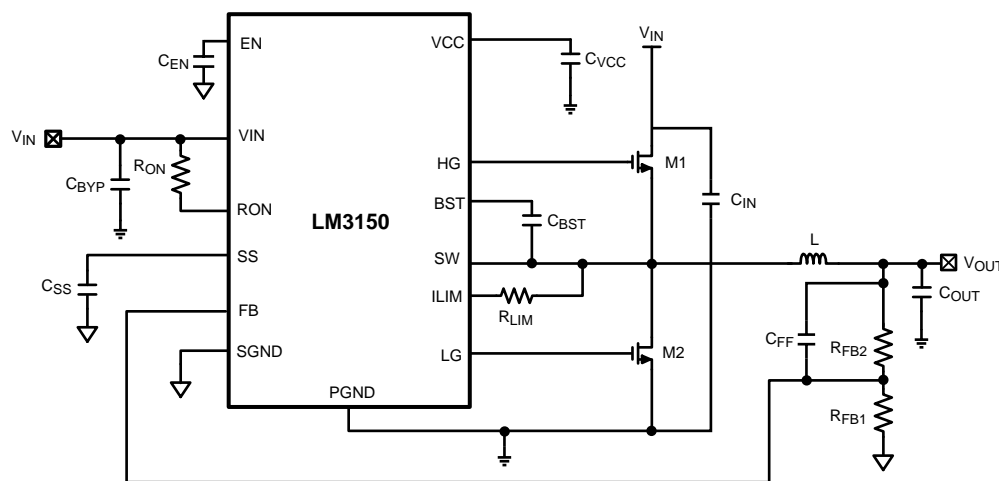

Figure 14. Design Example Schematic

9.2.1 Design Requirements

To properly size the components for the application, the designer needs the following parameters: Input voltage range, output voltage, output current range and required switching frequency. To summarize briefly, these four main parameters will affect the choices of component available to achieve a proper system behavior.

For the power supply, the input impedance of the supply rail should be low enough that the input current transient does not cause drop below the UVLO value. To maintain a relatively constant switching frequency as the input voltage varies, the LM3150 controller automatically adjusts the on-time inversely with the input voltage. The available frequency range for a given input voltage range, is determined by the duty-cycle, $D = V_{OUT}/V_{IN}$, and the minimum t_{ON} and t_{OFF} times. The feedback resistor values can be calculated based on the value of required output and feedback voltage. Regarding the output capacitor, its voltage rating must be greater than or equal to the output voltage. Similarly, the voltage rating for the input capacitor must be greater than the input voltage to be used in the application. Also, a feed-forward capacitor may be required for improved stability, based on the application.

The following sections describe in detail the design requirements for a typical LM3150 application.

Typical Application (continued)

9.2.2 Detailed Design Procedure

9.2.2.1 Custom Design with WEBENCH Tools

Click [here](#) to create a custom design using the LM3150 device with the WEBENCH® Power Designer.

1. Start by entering your V_{IN} , V_{OUT} and I_{OUT} requirements.
2. Optimize your design for key parameters like efficiency, footprint and cost using the optimizer dial and compare this design with other possible solutions from Texas Instruments.
3. WEBENCH Power Designer provides you with a customized schematic along with a list of materials with real time pricing and component availability.
4. In most cases, you will also be able to:
 - Run electrical simulations to see important waveforms and circuit performance,
 - Run thermal simulations to understand the thermal performance of your board,
 - Export your customized schematic and layout into popular CAD formats,
 - Print PDF reports for the design, and share your design with colleagues.
5. Get more information about WEBENCH tools at www.ti.com/webench.

9.2.2.2 LM3150 Design Procedure

To properly size the components for the application, the designer needs the following parameters: Input voltage range, output voltage, output current range and required switching frequency. These four main parameters will affect the choices of component available to achieve a proper system behavior.

Table 1. Bill of Materials

DESIGNATOR	VALUE	PARAMETERS	MANUFACTURER	PART NUMBER
C_{BST}	0.47 μ F	Ceramic, X7R, 16 V, 10%	TDK	C2012X7R1C474K
C_{BYP}	0.1 μ F	Ceramic, X7R, 50 V, 10%	TDK	C2012X7R1H104K
C_{EN}	1000 pF	Ceramic, X7R, 50 V, 10%	TDK	C1608X7R1H102K
C_{FF}	270 pF	Ceramic, C0G, 50 V, 5%	Vishay-Bccomponents	VJ0805A271JXACW1BC
C_{IN1}, C_{IN2}	10 μ F	Ceramic, X5R, 35 V, 20%	Taiyo Yuden	GMK325BJ106KN-T
C_{OUT1}, C_{OUT2}	150 μ F	Polymer Aluminum, 6.3 V, 20%	Panasonic	EEF-UE0J151R
C_{SS}	0.068 μ F	Ceramic, 0805, 25 V, 10%	Vishay	VJ0805Y683KXXA
C_{VCC}	4.7 μ F	Ceramic, X7R, 16 V, 10%	Murata	GRM21BR71C475KA73L
L1	1.65 μ H	Shielded Drum Core, 2.53 m Ω	Coilcraft	HA3778-AL
M1, M2	30 V	8 nC, $R_{DS(ON)}$ @4.5 V=10 m Ω	Renesas	RJK0305DPB
R_{FB1}	4.99 k Ω	1%, 0.125 W	Vishay-Dale	CRCW08054k99FKEA
R_{FB2}	22.6 k Ω	1%, 0.125 W	Vishay-Dale	CRCW080522k6FKEA
R_{LIM}	1.91 k Ω	1%, 0.125 W	Vishay-Dale	CRCW08051K91FKEA
R_{ON}	56.2 k Ω	1%, 0.125 W	Vishay-Dale	CRCW080556K2FKEA
U1	LM3150		Texas Instruments	LM3150

1. Define Power Supply Operating Conditions

- (a) $V_{OUT} = 3.3$ V
- (b) $V_{IN-MIN} = 6$ V, $V_{IN-TYP} = 12$ V, $V_{IN-MAX} = 24$ V
- (c) Typical Load Current = 12 A, Max Load Current = 15 A
- (d) Soft-Start time $t_{SS} = 5$ ms

2. Set Output Voltage with Feedback Resistors

$$R_{FB2} = R_{FB1} \left(\frac{V_{OUT}}{V_{FB}} - 1 \right) \quad (13)$$

$$R_{FB2} = 4.99 \text{ k}\Omega \left(\frac{3.3\text{V}}{0.6\text{V}} - 1 \right) \quad (14)$$

$$R_{FB2} = 22.455 \text{ k}\Omega \quad (15)$$

$R_{FB2} = 22.6 \text{ k}\Omega$, nearest 1% standard value.

3. Determine R_{ON} and f_S

$$D_{\min} = V_{OUT}/V_{IN-MAX} \quad (16)$$

$$D_{\min} = 3.3V/24V = 0.137 \quad (17)$$

$$D_{\max} = 3.3V / 6V = 0.55 \quad (18)$$

$$f_{S\max} = 0.137 / 200 \text{ ns} = 687 \text{ kHz} \quad (19)$$

$$D_{\max} = V_{OUT}/V_{IN-MIN} \quad (20)$$

$$t_{OFF} = (1-0.55)/687 \text{ kHz} = 654 \text{ ns} \quad (21)$$

t_{OFF} should meet the following criteria:

$$t_{OFF} > t_{OFF-MIN} + 200 \text{ ns} \quad (22)$$

$$t_{OFF} > 725 \text{ ns} \quad (23)$$

At the maximum switching frequency of 687 kHz, which is limited by the minimum on-time, the off-time of 654 ns is less than 725 ns. Therefore the switching frequency should be reduced and meet the following criteria:

$$f_S < (1 - D)/725 \text{ ns} \quad (24)$$

$$f_S < (1 - 0.55)/725 \text{ ns} = 620 \text{ kHz} \quad (25)$$

A switching frequency is arbitrarily chosen at 500 kHz which should allow for reasonable size components and satisfies the requirements above.

$$f_S = 500 \text{ kHz}$$

Using $f_S = 500 \text{ kHz}$ R_{ON} can be calculated as follows:

$$R_{ON} = [(V_{OUT} \times V_{IN}) - V_{OUT}] / (V_{IN} \times K \times f_S) + R_{OND} \quad (26)$$

$$R_{OND} = - [(V_{IN} - 1) \times (V_{IN} \times 16.5 + 100)] - 1000 \quad (27)$$

$$R_{OND} = - [(12 - 1) \times (12 \times 16.5 + 100)] - 1000 \quad (28)$$

$$R_{OND} = -4.3 \text{ k}\Omega \quad (29)$$

$$R_{ON} = [(3.3 \times 12) - 3.3] / (12 \times 100 \text{ pC} \times 500 \text{ kHz}) - 4.3 \text{ k}\Omega \quad (30)$$

$$R_{ON} = 56.2 \text{ k}\Omega \quad (31)$$

Next, check the desired minimum input voltage for R_{ON} using [Figure 15](#). This design will meet the desired minimum input voltage of 6 V.

4. Determine Inductor Required

(a) $ET = (24-3.3) \times (3.3/24) \times (1000/500) = 5.7 \text{ V } \mu\text{s}$

(b) From the inductor nomograph a 12-A load and 5.7 V μs calculation corresponds to a L44 type of inductor.

(c) Using the inductor designator L44 in [Table 2](#) the Coilcraft HA3778–AL 1.65- μH inductor is chosen.

5. Determine Output Capacitance

The voltage rating on the output capacitor should be greater than or equal to the output voltage. As a rule of thumb most capacitor manufacturers suggests not to exceed 90% of the capacitor rated voltage. In the case of multilayer ceramics the capacitance will tend to decrease dramatically as the applied voltage is increased towards the capacitor rated voltage. The capacitance can decrease by as much as 50% when the applied voltage is only 30% of the rated voltage. The chosen capacitor should also be able to handle the rms current which is equal to:

$$I_{rmsco} = I_{OUT} \times \frac{r}{\sqrt{12}} \quad (32)$$

For this design the chosen ripple current ratio, $r = 0.3$, represents the ratio of inductor peak-to-peak current to load current I_{OUT} . A good starting point for ripple ratio is 0.3 but it is acceptable to choose r between 0.25 to 0.5. The nomographs in this datasheet all use 0.3 as the ripple current ratio.

$$I_{rmsco} = 12 \times \frac{0.3}{\sqrt{12}} \quad (33)$$

$$I_{rmsco} = 1 \text{ A} \quad (34)$$

$$t_{ON} = (3.3V/12V)/500 \text{ kHz} = 550 \text{ ns} \quad (35)$$

Minimum output capacitance is:

$$C_{Omin} = 70 / (f_s^2 \times L) \quad (36)$$

$$C_{Omin} = 70 / (500 \text{ kHz}^2 \times 1.65 \text{ } \mu\text{H}) = 169 \text{ } \mu\text{F} \quad (37)$$

The maximum ESR allowed to prevent overvoltage protection during normal operation is:

$$ESR_{max} = (80 \text{ mV} \times L \times A_f) / ET \quad (38)$$

$$A_f = V_{OUT} / 0.6 \text{ without a feed-forward capacitor} \quad (39)$$

$$A_f = 1 \text{ with a feed-forward capacitor} \quad (40)$$

For this design a feed-forward capacitor will be used to help minimize output ripple.

$$ESR_{max} = (80 \text{ mV} \times 1.65 \text{ } \mu\text{H} \times 1) / 5.7 \text{ V } \mu\text{s} \quad (41)$$

$$ESR_{max} = 23 \text{ m}\Omega \quad (42)$$

The minimum ESR must meet both of the following criteria:

$$ESR_{min} \geq (15 \text{ mV} \times L \times A_f) / ET \quad (43)$$

$$ESR_{min} \geq [ET / (V_{IN} - V_{OUT})] \times (A_f / C_o) \quad (44)$$

$$ESR_{min} \geq (15 \text{ mV} \times 1.65 \text{ } \mu\text{H} \times 1) / 5.7 \text{ V } \mu\text{s} = 4.3 \text{ m}\Omega \quad (45)$$

$$ESR_{min} \geq [5.7 \text{ V } \mu\text{s} / (12 - 3.3)] \times (1 / 169 \text{ } \mu\text{F}) = 3.9 \text{ m}\Omega \quad (46)$$

Based on the above criteria two 150- μF polymer aluminum capacitors with a ESR = 12 m Ω each for a effective ESR in parallel of 6 m Ω was chosen from Panasonic. The part number is EEF-UE0J101P.

6. Determine Use of Feed-Forward Capacitor

From Step 5 the capacitor chosen in ESR is small enough that we should use a feed-forward capacitor. This is calculated from:

$$C_{ff} = \frac{V_{OUT}}{V_{IN-MIN} \times f_s} \times \frac{R_{FB1} + R_{FB2}}{R_{FB1} \times R_{FB2}}$$

$$C_{ff} = \frac{3.3\text{V}}{6\text{V} \times 500 \text{ kHz}} \times \frac{4.99 \text{ k}\Omega + 22.6 \text{ k}\Omega}{4.99 \text{ k}\Omega \times 22.6 \text{ k}\Omega} = 269 \text{ pF} \quad (47)$$

Let $C_{ff} = 270 \text{ pF}$, which is the closest next standard value.

7. MOSFET and R_{LIM} Selection

The LM3150 controller is designed to drive N-channel MOSFETs. For a maximum input voltage of 24 V we should choose N-channel MOSFETs with a maximum drain-source voltage, V_{DS} , greater than $1.2 \times 24 \text{ V} = 28.8 \text{ V}$. FETs with maximum V_{DS} of 30 V will be the first option. The combined total gate charge Q_{gtotal} of the high-side and low-side FET should satisfy the following:

$$Q_{gtotal} \leq I_{VCCCL} / f_s \quad (48)$$

$$Q_{gtotal} \leq 65 \text{ mA} / 500 \text{ kHz} \quad (49)$$

$$Q_{gtotal} \leq 130 \text{ nC} \quad (50)$$

Where I_{VCCCL} is the minimum current limit of VCC, over the temperature range, specified in the [Electrical Characteristics](#) table. The MOSFET gate charge Q_g is gathered from reading the V_{GS} vs Q_g curve of the MOSFET datasheet at the $V_{GS} = 5 \text{ V}$ for the high-side, M1, MOSFET and $V_{GS} = 6 \text{ V}$ for the low-side, M2, MOSFET.

The Renesas MOSFET RJK0305DPB has a gate charge of 10 nC at $V_{GS} = 5 \text{ V}$, and 12 nC at $V_{GS} = 6 \text{ V}$. This combined gate charge for a high-side, M1, and low-side, M2, MOSFET $12 \text{ nC} + 10 \text{ nC} = 22 \text{ nC}$ is less than 130 nC calculated Q_{gtotal} .

The calculated MOSFET power dissipation must be less than the max allowed power dissipation, P_{dmax} , as specified in the MOSFET data sheet. An approximate calculation of the FET power dissipated P_d , of the high-side and low-side FET is given by:

High-Side MOSFET

$$P_{\text{cond}} = I_{\text{out}}^2 \times R_{\text{DS(ON)}} \times D$$

$$P_{\text{sw}} = \frac{1}{2} \times V_{\text{in}} \times I_{\text{out}} \times Q_{\text{gd}} \times f_{\text{s}} \times \left(\frac{8.5}{V_{\text{CC}} - V_{\text{th}}} + \frac{6.8}{V_{\text{th}}} \right)$$

$$P_{\text{dh}} = P_{\text{cond}} + P_{\text{sw}}$$

$$P_{\text{cond}} = 12^2 \times 0.01 \times 0.275 = 0.396\text{W}$$

$$P_{\text{sw}} = \frac{1}{2} \times 12 \times 12 \times 1.5 \text{ nC} \times 500 \text{ kHz} \times \left(\frac{8.5}{6 - 2.5} + \frac{6.8}{2.5} \right) = 0.278\text{W}$$

$$P_{\text{dh}} = 0.396 + 0.278 = 0.674\text{W} \quad (51)$$

The max power dissipation of the RJK0305DPB is rated as 45 W for a junction temperature that is 125°C higher than the case temperature and a thermal resistance from the FET junction to case, θ_{JC} , of 2.78°C/W. When the FET is mounted onto the PCB, the PCB will have some additional thermal resistance such that the total system thermal resistance of the FET package and the PCB, θ_{JA} , is typically in the range of 30°C/W for this type of FET package. The max power dissipation, P_{dmax} , with the FET mounted onto a PCB with a 125°C junction temperature rise above ambient temperature and $\theta_{\text{JA}} = 30^\circ\text{C/W}$, can be estimated by:

$$P_{\text{dmax}} = 125^\circ\text{C} / 30^\circ\text{C/W} = 4.1 \text{ W} \quad (52)$$

The system calculated P_{dh} of 0.674 W is much less than the FET P_{dmax} of 4.1 W and therefore the RJK0305DPB max allowable power dissipation criteria is met.

Low-Side MOSFET

Primary loss is conduction loss given by:

$$P_{\text{dl}} = I_{\text{out}}^2 \times R_{\text{DS(ON)}} \times (1-D) = 12^2 \times 0.01 \times (1-0.275) = 1 \text{ W} \quad (53)$$

P_{dl} is also less than the P_{dmax} specified on the RJK0305DPB MOSFET data sheet.

However, it is not always necessary to use the same MOSFET for both the high-side and low-side. For most applications it is necessary to choose the high-side MOSFET with the lowest gate charge and the low-side MOSFET is chosen for the lowest allowed $R_{\text{DS(ON)}}$. The plateau voltage of the FET V_{GS} vs Q_{g} curve must be less than $V_{\text{CC}} - 750 \text{ mV}$.

The current limit resistor, R_{LIM} , is calculated by estimating the $R_{\text{DS(ON)}}$ of the low-side FET at the maximum junction temperature of 100°C. By choosing to go into current limit when the average output load current is 20% higher than the output load current of 12A while the inductor ripple current ratio is 1/3 of the load current will make $I_{\text{CL}} = 10.4 \text{ A}$. Then the following calculation of R_{LIM} is:

$$R_{\text{LIM}} = (10.4 \times 0.014) / (75 \times 10^{-6}) = 1.9 \text{ k}\Omega \quad (54)$$

Let $R_{\text{LIM}} = 1.91 \text{ k}\Omega$ which is the next standard value.

8. Calculate Input Capacitance

The input capacitor should be chosen so that the voltage rating is greater than the maximum input voltage which for this example is 24 V. Similar to the output capacitor, the voltage rating needed will depend on the type of capacitor chosen. The input capacitor should also be able to handle the input rms current, which is a maximum of approximately $0.5 \times I_{\text{OUT}}$. For this example the rms input current is approximately $0.5 \times 12 \text{ A} = 6 \text{ A}$.

The minimum capacitance with a maximum 5% input ripple $\Delta V_{\text{IN-MAX}} = (0.05 \times 12) = 0.6 \text{ V}$:

$$C_{\text{IN}} = [12 \times 0.275 \times (1-0.275)] / [500 \text{ kHz} \times 0.6] = 8 \mu\text{F} \quad (55)$$

To handle the large input rms current 2 ceramic capacitors are chosen at 10 μF each with a voltage rating of 50 V and case size of 1210. Each ceramic capacitor is capable of handling 3 A of rms current. A aluminum electrolytic of 5 times the combined input capacitance, $5 \times 20 \mu\text{F} = 100 \mu\text{F}$, is chosen to provide input voltage filter damping because of the low ESR ceramic input capacitors.

$C_{\text{BYP}} = 0.1 \mu\text{F}$ ceramic with a voltage rating greater than maximum V_{IN}

9. Calculate Soft-Start Capacitor

The soft start-time should be greater than the input voltage rise time and also satisfy the following equality to maintain a smooth transition of the output voltage to the programmed regulation voltage during startup. The desired soft-start time, t_{SS} , of 5 ms also must satisfy the equality in [Equation 12](#), by using the chosen component values through the previous steps as shown below:

$$5 \text{ ms} > (3.3\text{V} \times 300 \text{ }\mu\text{F}) / (1.2 \times 12\text{A} - 12\text{A}) \quad (56)$$

$$5 \text{ ms} > 0.412 \text{ ms} \quad (57)$$

Because the desired soft-start time satisfies the equality in [Equation 12](#), the soft start capacitor is calculated as:

$$C_{SS} = (7.7 \text{ }\mu\text{A} \times 5 \text{ ms}) / 0.6\text{V} = 0.064 \text{ }\mu\text{F} \quad (58)$$

Let $C_{SS} = 0.068 \text{ }\mu\text{F}$, which is the next closest standard value. This should be a ceramic cap with a voltage rating greater than 10 V.

10. C_{VCC} , C_{EN} , and C_{BST}

$C_{VCC} = 4.7\text{-}\mu\text{F}$ ceramic with a voltage rating greater than 10 V

$C_{EN} = 1000\text{-pF}$ ceramic with a voltage rating greater than 10 V

$C_{BST} = 0.47\text{-}\mu\text{F}$ ceramic with a voltage rating greater than 10 V

9.2.2.3 Design Guide

The design guide provides the equations required to design with the LM3150 controller. WEBENCH design tool can be used with or in place of this section for a more complete and simplified design process.

1. Define Power Supply Operating Conditions

- (a) Required Output Voltage
- (b) Maximum and Minimum DC Input Voltage
- (c) Maximum Expected Load Current during Normal Operation
- (d) Soft-Start Time

2. Set Output Voltage With Feedback Resistors

$$V_{OUT} = V_{FB} \times \frac{(R_{FB1} + R_{FB2})}{R_{FB1}}$$

where

- R_{FB1} is the bottom resistor
- R_{FB2} is the top resistor

(59)

3. Determine R_{ON} and f_s

The available frequency range for a given input voltage range, is determined by the duty-cycle, $D = V_{OUT}/V_{IN}$, and the minimum t_{ON} and t_{OFF} times as specified in the *Electrical Characteristics* table. The maximum frequency is thus, $f_{smax} = D_{min}/t_{ON-MIN}$. Where $D_{min} = V_{OUT}/V_{IN-MAX}$, is the minimum duty-cycle. The off-time will need to be less than the minimum off-time t_{OFF} as specified in the *Electrical Characteristics* table plus any turnoff and turnon delays of the MOSFETs which can easily add another 200 ns. The minimum off-time will occur at maximum duty cycle D_{max} and will determine if the frequency chosen will allow for the minimum desired input voltage. The requirement for minimum off-time is $t_{OFF} = (1 - D_{max})/f_s \geq (t_{OFF-MIN} + 200 \text{ ns})$. If t_{OFF} does not meet this requirement it will be necessary to choose a smaller switching frequency f_s .

Choose R_{ON} so that the switching frequency at your typical input voltage matches your f_s chosen above using the following formula:

$$R_{ON} = [(V_{OUT} \times V_{IN}) - V_{OUT}] / (V_{IN} \times K \times f_s) + R_{OND} \tag{60}$$

$$R_{OND} = - [(V_{IN} - 1) \times (V_{IN} \times 16.5 + 100)] - 1000 \tag{61}$$

Use [Figure 15](#) to determine if the calculated R_{ON} will allow for the minimum desired input voltage. If the minimum desired input voltage is not met, recalculate R_{ON} for a lower switching frequency.

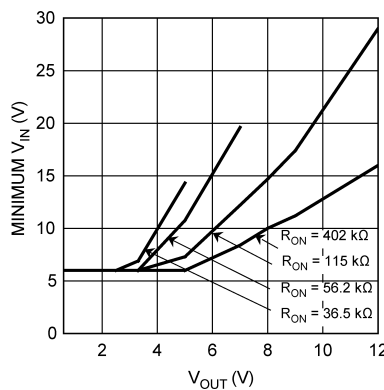

Figure 15. Minimum V_{IN} vs. V_{OUT}
 $I_{OUT} = 10 \text{ A}$

4. Determine Inductor Required Using [Figure 16](#)

To use the nomograph in [Figure 16](#), calculate the inductor volt-microsecond constant ET from the following formula:

$$ET = (V_{inmax} - V_{OUT}) \times \frac{V_{OUT}}{V_{inmax}} \times \frac{1000}{f_s} \text{ (V} \times \mu\text{s)}$$

where

- f_s is in kHz units (62)

The intersection of the Load Current and the Volt-microseconds lines on the chart below will determine which inductors are capable for use in the design. Figure 16 shows a sample of parts that can be used. The offline calculator tools and WEBENCH will fully calculate the requirements for the components needed for the design.

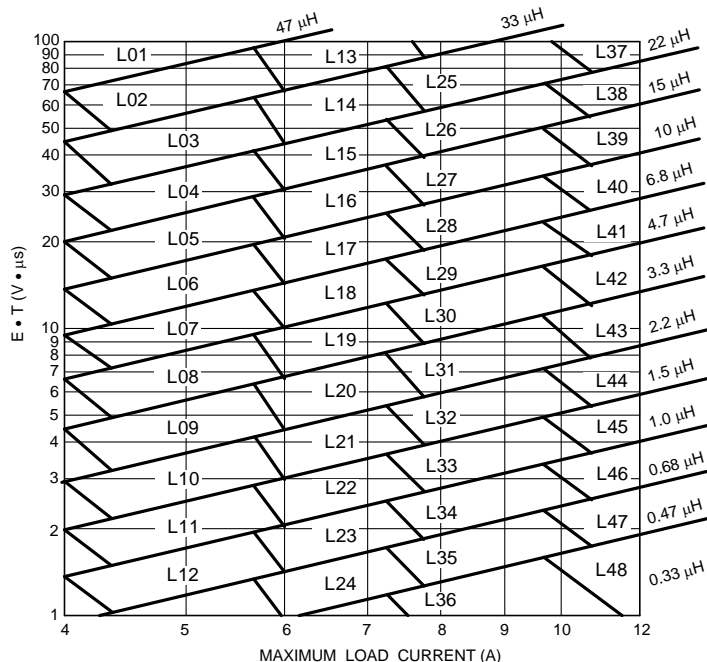

Figure 16. Inductor Nomograph

Table 2. Inductor Selection Table

INDUCTOR DESIGNATOR	INDUCTANCE (μH)	CURRENT (A)	PART NAME	VENDOR
L01	47	7-9		
L02	33	7-9	SER2817H-333KL	COILCRAFT
L03	22	7-9	SER2814H-223KL	COILCRAFT
L04	15	7-9	7447709150	WURTH
L05	10	7-9	RLF12560T-100M7R5	TDK
L06	6.8	7-9	B82477-G4682-M	EPCOS
L07	4.7	7-9	B82477-G4472-M	EPCOS
L08	3.3	7-9	DR1050-3R3-R	COOPER
L09	2.2	7-9	MSS1048-222	COILCRAFT
L10	1.5	7-9	SRU1048-1R5Y	BOURNS
L11	1	7-9	DO3316P-102	COILCRAFT
L12	0.68	7-9	DO3316H-681	COILCRAFT
L13	33	9-12		
L14	22	9-12	SER2918H-223	COILCRAFT
L15	15	9-12	SER2814H-153KL	COILCRAFT
L16	10	9-12	7447709100	WURTH
L17	6.8	9-12	SPT50H-652	COILCRAFT
L18	4.7	9-12	SER1360-472	COILCRAFT
L19	3.3	9-12	MSS1260-332	COILCRAFT
L20	2.2	9-12	DR1050-2R2-R	COOPER

Table 2. Inductor Selection Table (continued)

INDUCTOR DESIGNATOR	INDUCTANCE (μH)	CURRENT (A)	PART NAME	VENDOR
L21	1.5	9-12	DR1050-1R5-R	COOPER
L22	1	9-12	DO3316H-102	COILCRAFT
L23	0.68	9-12		
L24	0.47	9-12		
L25	22	12-15	SER2817H-223KL	COILCRAFT
L26	15	12-15		
L27	10	12-15	SER2814L-103KL	COILCRAFT
L28	6.8	12-15	7447709006	WURTH
L29	4.7	12-15	7447709004	WURTH
L30	3.3	12-15		
L31	2.2	12-15		
L32	1.5	12-15	MLC1245-152	COILCRAFT
L33	1	12-15		
L34	0.68	12-15	DO3316H-681	COILCRAFT
L35	0.47	12-15		
L36	0.33	12-15	DR73-R33-R	COOPER
L37	22	15-		
L38	15	15-	SER2817H-153KL	COILCRAFT
L39	10	15-	SER2814H-103KL	COILCRAFT
L40	6.8	15-		
L41	4.7	15-	SER2013-472ML	COILCRAFT
L42	3.3	15-	SER2013-362L	COILCRAFT
L43	2.2	15-		
L44	1.5	15-	HA3778-AL	COILCRAFT
L45	1	15-	B82477-G4102-M	EPCOS
L46	0.68	15-		
L47	0.47	15-		
L48	0.33	15-		

5. Determine Output Capacitance

Typical hysteretic COT converters similar to the LM3150 controller require a certain amount of ripple that is generated across the ESR of the output capacitor and fed back to the error comparator. Emulated Ripple Mode control built into the LM3150 controller will recreate a similar ripple signal and thus the requirement for output capacitor ESR will decrease compared to a typical Hysteretic COT converter. The emulated ripple is generated by sensing the voltage signal across the low-side FET and is then compared to the FB voltage at the error comparator input to determine when to initiate the next on-time period.

$$C_{Omin} = 70 / (f_s^2 \times L) \quad (63)$$

The maximum ESR allowed to prevent overvoltage protection during normal operation is:

$$ESR_{max} = (80 \text{ mV} \times L \times A_f) / ET_{min} \quad (64)$$

ET_{min} is calculated using V_{IN-MIN}

$A_f = V_{OUT} / 0.6$ if there is no feed-forward capacitor used

$A_f = 1$ if there is a feed-forward capacitor used

The minimum ESR must meet both of the following criteria:

$$ESR_{min} \geq (15 \text{ mV} \times L \times A_f) / ET_{max} \quad (65)$$

$$ESR_{min} \geq [ET_{max} / (V_{IN} - V_{OUT})] \times (A_f / C_O) \quad (66)$$

ET_{max} is calculated using V_{IN-MAX} .

Any additional parallel capacitors should be chosen so that their effective impedance will not negatively attenuate the output ripple voltage.

6. Determine The Use of Feed-Forward Capacitor

Certain applications may require a feed-forward capacitor for improved stability and easier selection of available output capacitance. Use the following equation to calculate the value of C_{ff} .

$$Z_{FB} = (R_{FB1} \times R_{FB2}) / (R_{FB1} + R_{FB2}) \quad (67)$$

$$C_{ff} = V_{OUT} / (V_{IN-MIN} \times f_s \times Z_{FB}) \quad (68)$$

7. MOSFET and R_{LIM} Selection

The high-side and low-side FETs must have a drain to source (V_{DS}) rating of at least $1.2 \times V_{IN}$.

Use the following equations to calculate the desired target value of the low-side FET $R_{DS(ON)}$ for current limit.

$$R_{LIM}(T_j) = \frac{I_{CL} \times R_{DS(ON)max}}{I_{LIM-TH}(T_j)} \quad (69)$$

$$I_{LIM-TH}(T_j) = I_{LIM-TH} \times [1 + 3.3 \times 10^{-3} \times (T_j - 27)] \quad (70)$$

The gate drive current from VCC must not exceed the minimum current limit of VCC. The drive current from VCC can be calculated with:

$$I_{VCCdrive} = Q_{gtotal} \times f_s$$

where

- Q_{gtotal} is the combined total gate charge of the high-side and low-side FETs (71)

The plateau voltage of the FET V_{GS} vs Q_g curve, as shown in [Figure 17](#), must be less than $VCC - 750 \text{ mV}$.

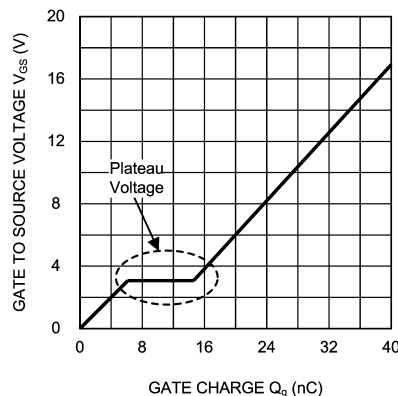

Figure 17. Typical MOSFET Gate Charge Curve

See following design example for estimated power dissipation calculation.

8. Calculate Input Capacitance

The main parameters for the input capacitor are the voltage rating, which must be greater than or equal to the maximum DC input voltage of the power supply, and its rms current rating. The maximum rms current is approximately 50% of the maximum load current.

$$C_{IN} = \frac{I_{omax} \times D \times (1-D)}{f_s \times \Delta V_{IN-MAX}}$$

where

- ΔV_{IN-MAX} is the maximum allowable input ripple voltage. A good starting point for the input ripple voltage is 5% of V_{IN} (72)

When using low ESR ceramic capacitors on the input of the LM3150 controller, a resonant circuit can be formed with the impedance of the input power supply and parasitic impedance of long leads/PCB traces to the LM3150 input capacitors. TI recommends using a damping capacitor under these circumstances, such as aluminum electrolytic that will prevent ringing on the input. The damping capacitor should be chosen to be approximately five times greater than the parallel ceramic capacitors combination. The total input capacitance should be greater than 10 times the input inductance of the power supply leads/PCB trace. The damping capacitor should also be chosen to handle its share of the rms input current which is shared proportionately with the parallel impedance of the ceramic capacitors and aluminum electrolytic at the LM3150 switching frequency.

The C_{BYP} capacitor should be placed directly at the VIN pin. The recommended value is 0.1 μF .

9. Calculate Soft-Start Capacitor

$$C_{SS} = \frac{I_{SS} \times t_{SS}}{V_{ref}}$$

where

- t_{SS} is the soft-start time in seconds
- $V_{ref} = 0.6V$

(73)

10. C_{VCC} , C_{BST} , and C_{EN}

C_{VCC} should be placed directly at the VCC pin with a recommended value of 1 μF to 4.7 μF . C_{BST} creates a voltage used to drive the gate of the high-side FET. It is charged during the SW off-time. The recommended value for C_{BST} is 0.47 μF . The EN bypass capacitor, C_{EN} , recommended value is 1000 pF when driving the EN pin from open-drain type of signal.

9.2.3 Application Curves

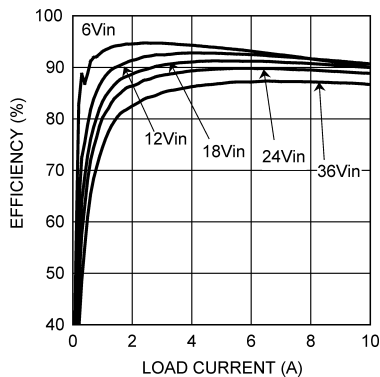

Figure 18. 250-kHz Efficiency vs Load

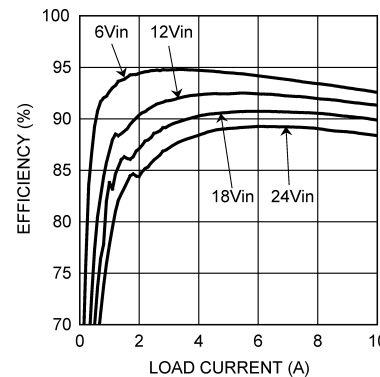

Figure 19. 500-kHz Efficiency vs Load

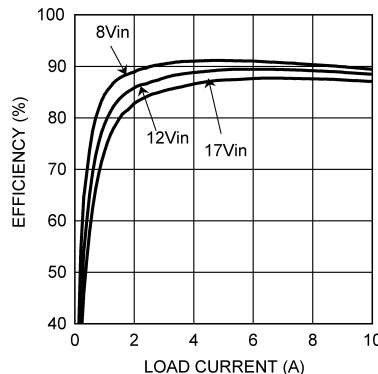

Figure 20. 750-kHz Efficiency vs Load

10 Power Supply Recommendations

The LM3150 controller is designed to operate from various DC power supplies. VIN input should be protected from reversal voltage and voltage dump over 42 volts. The impedance of the input supply rail should be low enough that the input current transient does not cause drop below VIN UVLO level. If the input supply is connected by using long wires, additional bulk capacitance may be required in addition to normal input capacitor.

11 Layout

11.1 Layout Guidelines

It is good practice to layout the power components first, such as the input and output capacitors, FETs, and inductor. The first priority is to make the loop between the input capacitors and the source of the low-side FET to be very small and tie the grounds of the low-side FET and input capacitor directly to each other and then to the ground plane through vias. As shown in Figure 21 when the input capacitor ground is tied directly to the source of the low-side FET, parasitic inductance in the power path, along with noise coupled into the ground plane, are reduced.

The switch node is the next item of importance. The switch node should be made only as large as required to handle the load current. There are fast voltage transitions occurring in the switch node at a high frequency, and if the switch node is made too large it may act as an antennae and couple switching noise into other parts of the circuit. For high power designs, it is recommended to use a multilayer board. The FETs are going to be the largest heat generating devices in the design, and as such, care should be taken to remove the heat. On multilayer boards using exposed-pad packages for the FETs such as the power-pak SO-8, vias should be used under the FETs to the same plane on the interior layers to help dissipate the heat and cool the FETs. For the typical single FET Power-Pak type FETs, the high-side FET DAP is VIN. The VIN plane should be copied to the other interior layers to the bottom layer for maximum heat dissipation. Likewise, the DAP of the low-side FET is connected to the SW node and the SW node shape should be duplicated to the other PCB layers for maximum heat dissipation.

See the Evaluation Board application note AN-1900 (SNVA371) for an example of a typical multilayer board layout, and the Demonstration Board Reference Design Application Note for a typical 2-layer board layout. Each design allows for single-sided component mounting.

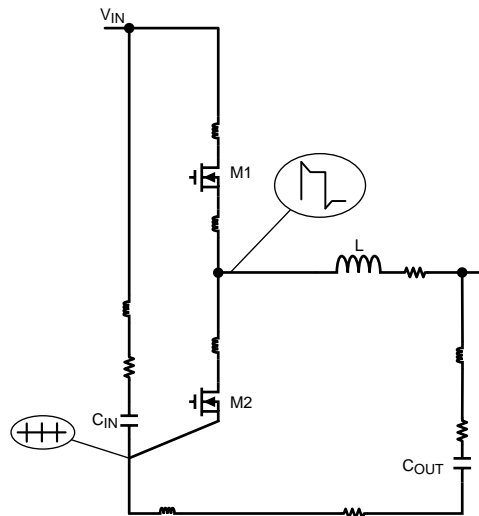

Figure 21. Schematic of Parasitics

11.2 Layout Example

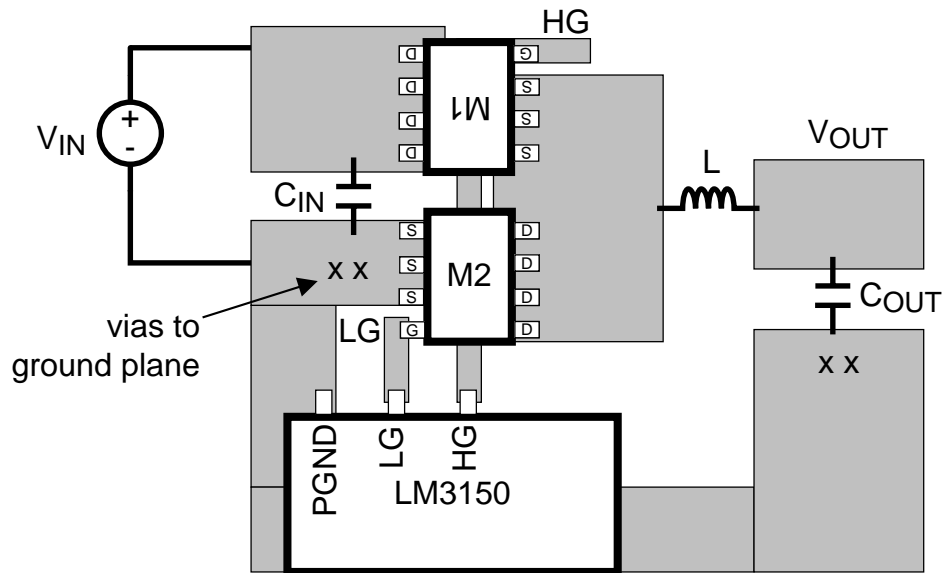

Figure 22. PCB Placement of Power Stage

12 Device and Documentation Support

12.1 Documentation Support

12.1.1 Custom Design with WEBENCH Tools

[Click here](#) to create a custom design using the LM3150 device with the WEBENCH® Power Designer.

1. Start by entering your V_{IN} , V_{OUT} and I_{OUT} requirements.
2. Optimize your design for key parameters like efficiency, footprint and cost using the optimizer dial and compare this design with other possible solutions from Texas Instruments.
3. WEBENCH Power Designer provides you with a customized schematic along with a list of materials with real time pricing and component availability.
4. In most cases, you will also be able to:
 - Run electrical simulations to see important waveforms and circuit performance,
 - Run thermal simulations to understand the thermal performance of your board,
 - Export your customized schematic and layout into popular CAD formats,
 - Print PDF reports for the design, and share your design with colleagues.
5. Get more information about WEBENCH tools at www.ti.com/webench.

12.1.2 Receiving Notification of Documentation Updates

To receive notification of documentation updates, navigate to the device product folder on ti.com. In the upper right corner, click on *Alert me* to register and receive a weekly digest of any product information that has changed. For change details, review the revision history included in any revised document.

12.1.3 Third-Party Products Disclaimer

TI'S PUBLICATION OF INFORMATION REGARDING THIRD-PARTY PRODUCTS OR SERVICES DOES NOT CONSTITUTE AN ENDORSEMENT REGARDING THE SUITABILITY OF SUCH PRODUCTS OR SERVICES OR A WARRANTY, REPRESENTATION OR ENDORSEMENT OF SUCH PRODUCTS OR SERVICES, EITHER ALONE OR IN COMBINATION WITH ANY TI PRODUCT OR SERVICE.

12.1.4 Related Documentation

For related documentation see the following:

- *AN-1900 LM3150 Evaluation Boards* [SNVA371](#)

12.2 Community Resources

The following links connect to TI community resources. Linked contents are provided "AS IS" by the respective contributors. They do not constitute TI specifications and do not necessarily reflect TI's views; see TI's [Terms of Use](#).

TI E2E™ Online Community *TI's Engineer-to-Engineer (E2E) Community*. Created to foster collaboration among engineers. At e2e.ti.com, you can ask questions, share knowledge, explore ideas and help solve problems with fellow engineers.

Design Support *TI's Design Support* Quickly find helpful E2E forums along with design support tools and contact information for technical support.

12.3 Trademarks

PowerWise, E2E are trademarks of Texas Instruments.

WEBENCH, SIMPLE SWITCHER are registered trademarks of Texas Instruments.

All other trademarks are the property of their respective owners.

12.4 Electrostatic Discharge Caution



These devices have limited built-in ESD protection. The leads should be shorted together or the device placed in conductive foam during storage or handling to prevent electrostatic damage to the MOS gates.

12.5 Glossary



[SLYZ022](#) — *TI Glossary*.

This glossary lists and explains terms, acronyms, and definitions.

13 Mechanical, Packaging, and Orderable Information

The following pages include mechanical, packaging, and orderable information. This information is the most current data available for the designated devices. This data is subject to change without notice and revision of this document. For browser-based versions of this data sheet, refer to the left-hand navigation.

PACKAGING INFORMATION

Orderable Device	Status (1)	Package Type	Package Drawing	Pins	Package Qty	Eco Plan (2)	Lead finish/ Ball material (6)	MSL Peak Temp (3)	Op Temp (°C)	Device Marking (4/5)	Samples
LM3150MH/NOPB	ACTIVE	HTSSOP	PWP	14	94	RoHS & Green	SN	Level-1-260C-UNLIM	-40 to 125	LM3150 MH	
LM3150MHE/NOPB	ACTIVE	HTSSOP	PWP	14	250	RoHS & Green	SN	Level-1-260C-UNLIM	-40 to 125	LM3150 MH	
LM3150MHX/NOPB	ACTIVE	HTSSOP	PWP	14	2500	RoHS & Green	SN	Level-1-260C-UNLIM	-40 to 125	LM3150 MH	

(1) The marketing status values are defined as follows:

ACTIVE: Product device recommended for new designs.

LIFEBUY: TI has announced that the device will be discontinued, and a lifetime-buy period is in effect.

NRND: Not recommended for new designs. Device is in production to support existing customers, but TI does not recommend using this part in a new design.

PREVIEW: Device has been announced but is not in production. Samples may or may not be available.

OBSELETE: TI has discontinued the production of the device.

(2) **RoHS:** TI defines "RoHS" to mean semiconductor products that are compliant with the current EU RoHS requirements for all 10 RoHS substances, including the requirement that RoHS substance do not exceed 0.1% by weight in homogeneous materials. Where designed to be soldered at high temperatures, "RoHS" products are suitable for use in specified lead-free processes. TI may reference these types of products as "Pb-Free".

RoHS Exempt: TI defines "RoHS Exempt" to mean products that contain lead but are compliant with EU RoHS pursuant to a specific EU RoHS exemption.

Green: TI defines "Green" to mean the content of Chlorine (Cl) and Bromine (Br) based flame retardants meet JS709B low halogen requirements of <=1000ppm threshold. Antimony trioxide based flame retardants must also meet the <=1000ppm threshold requirement.

(3) MSL, Peak Temp. - The Moisture Sensitivity Level rating according to the JEDEC industry standard classifications, and peak solder temperature.

(4) There may be additional marking, which relates to the logo, the lot trace code information, or the environmental category on the device.

(5) Multiple Device Markings will be inside parentheses. Only one Device Marking contained in parentheses and separated by a "~" will appear on a device. If a line is indented then it is a continuation of the previous line and the two combined represent the entire Device Marking for that device.

(6) Lead finish/Ball material - Orderable Devices may have multiple material finish options. Finish options are separated by a vertical ruled line. Lead finish/Ball material values may wrap to two lines if the finish value exceeds the maximum column width.

Important Information and Disclaimer:The information provided on this page represents TI's knowledge and belief as of the date that it is provided. TI bases its knowledge and belief on information provided by third parties, and makes no representation or warranty as to the accuracy of such information. Efforts are underway to better integrate information from third parties. TI has taken and continues to take reasonable steps to provide representative and accurate information but may not have conducted destructive testing or chemical analysis on incoming materials and chemicals. TI and TI suppliers consider certain information to be proprietary, and thus CAS numbers and other limited information may not be available for release.

In no event shall TI's liability arising out of such information exceed the total purchase price of the TI part(s) at issue in this document sold by TI to Customer on an annual basis.

TAPE AND REEL INFORMATION

QUADRANT ASSIGNMENTS FOR PIN 1 ORIENTATION IN TAPE

*All dimensions are nominal

Device	Package Type	Package Drawing	Pins	SPQ	Reel Diameter (mm)	Reel Width W1 (mm)	A0 (mm)	B0 (mm)	K0 (mm)	P1 (mm)	W (mm)	Pin1 Quadrant
LM3150MHE/NOPB	HTSSOP	PWP	14	250	178.0	12.4	6.95	5.6	1.6	8.0	12.0	Q1
LM3150MHX/NOPB	HTSSOP	PWP	14	2500	330.0	12.4	6.95	5.6	1.6	8.0	12.0	Q1

TAPE AND REEL BOX DIMENSIONS



*All dimensions are nominal

Device	Package Type	Package Drawing	Pins	SPQ	Length (mm)	Width (mm)	Height (mm)
LM3150MHE/NOPB	HTSSOP	PWP	14	250	208.0	191.0	35.0
LM3150MHX/NOPB	HTSSOP	PWP	14	2500	367.0	367.0	35.0

TUBE

*All dimensions are nominal

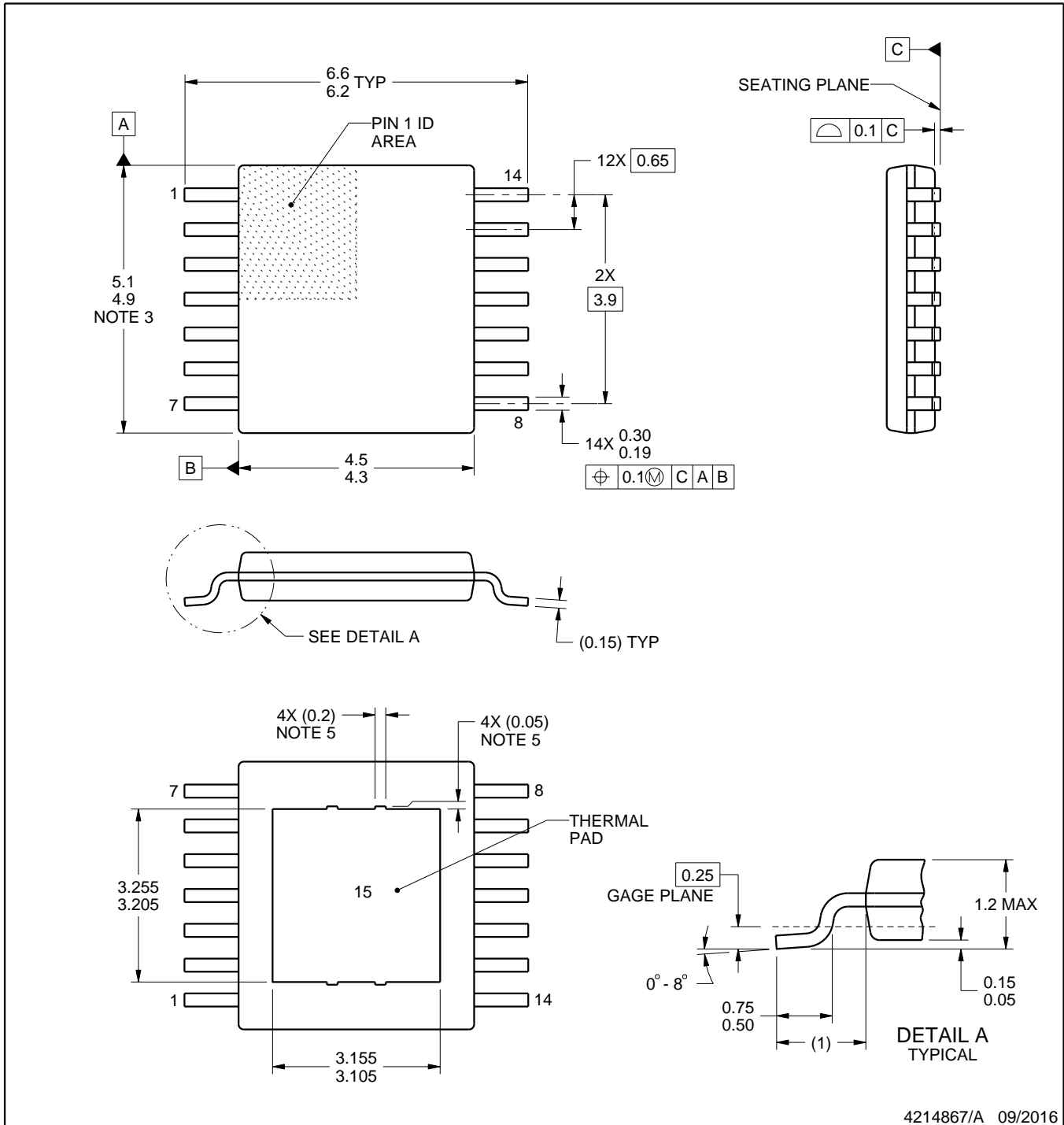
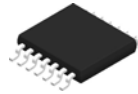
Device	Package Name	Package Type	Pins	SPQ	L (mm)	W (mm)	T (μm)	B (mm)
LM3150MH/NOPB	PWP	HTSSOP	14	94	495	8	2514.6	4.06



4214867/A 09/2016

NOTES:

PowerPAD is a trademark of Texas Instruments.

1. All linear dimensions are in millimeters. Any dimensions in parenthesis are for reference only. Dimensioning and tolerancing per ASME Y14.5M.
2. This drawing is subject to change without notice.
3. This dimension does not include mold flash, protrusions, or gate burrs. Mold flash, protrusions, or gate burrs shall not exceed 0.15 mm per side.
4. Reference JEDEC registration MO-153.
5. Features may differ and may not be present.

EXAMPLE STENCIL DESIGN

PWP0014A

PowerPAD™ TSSOP - 1.2 mm max height

PLASTIC SMALL OUTLINE

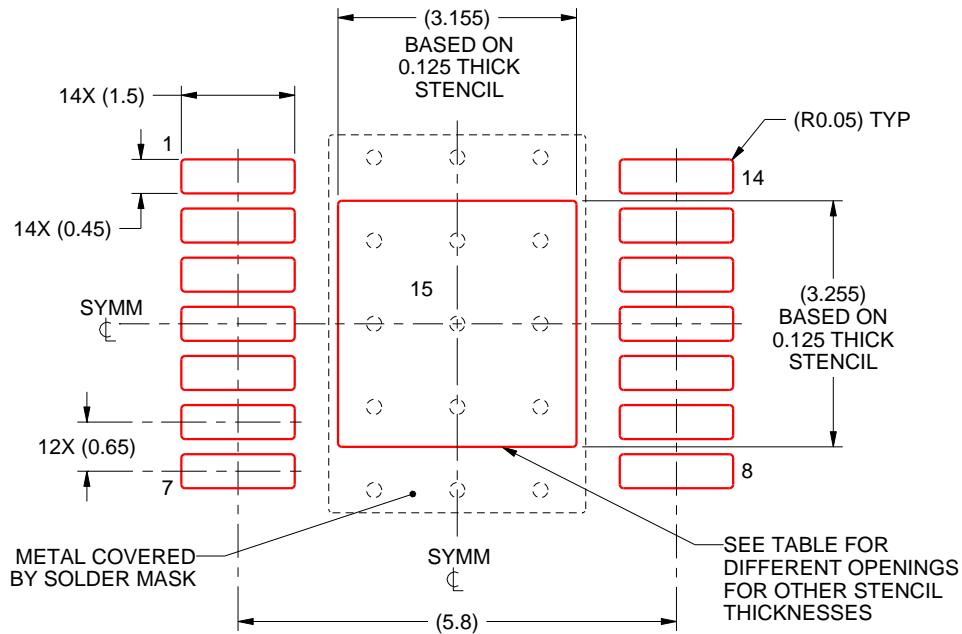

SOLDER PASTE EXAMPLE
 EXPOSED PAD
 100% PRINTED SOLDER COVERAGE BY AREA
 SCALE:10X

STENCIL THICKNESS	SOLDER STENCIL OPENING
0.1	3.53 X 3.64
0.125	3.155 X 3.255 (SHOWN)
0.15	2.88 X 2.97
0.175	2.67 X 2.75

4214867/A 09/2016

NOTES: (continued)

10. Laser cutting apertures with trapezoidal walls and rounded corners may offer better paste release. IPC-7525 may have alternate design recommendations.
11. Board assembly site may have different recommendations for stencil design.

IMPORTANT NOTICE AND DISCLAIMER

TI PROVIDES TECHNICAL AND RELIABILITY DATA (INCLUDING DATA SHEETS), DESIGN RESOURCES (INCLUDING REFERENCE DESIGNS), APPLICATION OR OTHER DESIGN ADVICE, WEB TOOLS, SAFETY INFORMATION, AND OTHER RESOURCES "AS IS" AND WITH ALL FAULTS, AND DISCLAIMS ALL WARRANTIES, EXPRESS AND IMPLIED, INCLUDING WITHOUT LIMITATION ANY IMPLIED WARRANTIES OF MERCHANTABILITY, FITNESS FOR A PARTICULAR PURPOSE OR NON-INFRINGEMENT OF THIRD PARTY INTELLECTUAL PROPERTY RIGHTS.

These resources are intended for skilled developers designing with TI products. You are solely responsible for (1) selecting the appropriate TI products for your application, (2) designing, validating and testing your application, and (3) ensuring your application meets applicable standards, and any other safety, security, regulatory or other requirements.

These resources are subject to change without notice. TI grants you permission to use these resources only for development of an application that uses the TI products described in the resource. Other reproduction and display of these resources is prohibited. No license is granted to any other TI intellectual property right or to any third party intellectual property right. TI disclaims responsibility for, and you will fully indemnify TI and its representatives against, any claims, damages, costs, losses, and liabilities arising out of your use of these resources.

TI's products are provided subject to [TI's Terms of Sale](#) or other applicable terms available either on ti.com or provided in conjunction with such TI products. TI's provision of these resources does not expand or otherwise alter TI's applicable warranties or warranty disclaimers for TI products.

TI objects to and rejects any additional or different terms you may have proposed.

Mailing Address: Texas Instruments, Post Office Box 655303, Dallas, Texas 75265
Copyright © 2022, Texas Instruments Incorporated

单击下面可查看定价，库存，交付和生命周期等信息

[>>TI\(德州仪器\)](#)