

1.0MHz, 2A Synchronous Step-Down Converter

FEATURES

- High Efficiency: Up to 96% (@3.3V)
- 1.0MHz Constant Frequency Operation
- 2A Output Current
- No Schottky Diode Required
- 2.5V to 6.0V Input Voltage Range
- Output Voltage as Low as 0.6V
- PFM Mode for High Efficiency in Light Load
- 100% Duty Cycle in Dropout Operation
- Low Quiescent Current: 40 μ A
- Short Circuit Protection
- Thermal Fault Protection
- Inrush Current Limit and Soft Start
- Input over voltage protection (OVP)
- <1 μ A Shutdown Current
- SOT23-5 Package

APPLICATIONS

- Cellular and Smart Phones
- Wireless and DSL Modems
- PDAs
- Portable Instruments
- Digital Still and Video Cameras
- PC Cards

TYPICAL APPLICATION

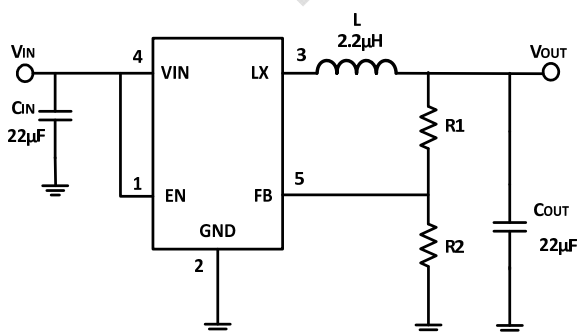

Figure 1. Basic Application Circuit

GENERAL DESCRIPTION

The TMI3411 is a 1.0MHz constant frequency, current mode step-down converter. It is ideal for portable equipment requiring very high current up to 2A from single-cell Lithium-ion batteries while still achieving over 90% efficiency during peak load conditions. The TMI3411 also can run at 100% duty cycle for low dropout operation, extending battery life in portable systems while light load operation provides very low output ripple for noise sensitive applications. The TMI3411 can supply up to 2A output load current from a 2.5V to 6V input voltage and the output voltage can be regulated as low as 0.6V. The high switching frequency minimizes the size of external components while keeping switching losses low. The internal slope compensation setting allows the device to operate with smaller inductor values to optimize size and provide efficient operation. The TMI3411 is offered in a 5-pin, SOT package, and is available in an adjustable version.

This device offers two operation modes, PWM control and PFM Mode switching control, which allows a high efficiency over the wider range of the load.

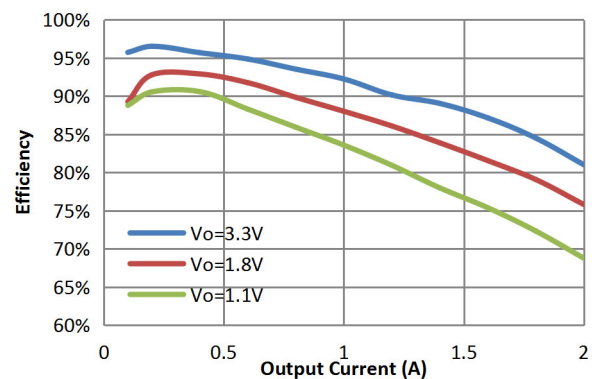
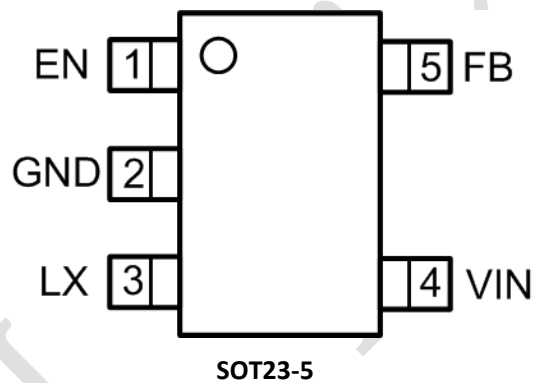

Figure 2. Efficiency ($V_{IN}=5V$, $I_o=0.1A$ to $2A$)

ABSOLUTE MAXIMUM RATINGS (Note 1)

Parameter	Value	Unit
Input Supply Voltage	-0.3~6.5	V
LX Voltages	-0.3~6.5	V
EN, FB Voltage	-0.3~6.5	V
Storage Temperature Range	-65~150	°C
Junction Temperature <small>(Note2)</small>	160	°C
Power Dissipation	600	mW
Lead Temperature (Soldering,10s)	260	°C

PACKAGE/ORDER INFORMATION



Top Mark: T26AXXX (T26A: Device Code, XXX: Inside Code)

Part Number	Package	Top mark	Quantity/ Reel
TMI3411	SOT23-5	T26AXXX	3000

TMI3411 devices are Pb-free and RoHS compliant.

PIN DESCRIPTION

Pin	Name	Function
1	EN	Chip Enable Pin. Drive EN above 1.5V to turn on the part. Drive EN below 0.3V to turn it off. Do not leave EN floating.
2	GND	Ground pin.
3	LX	Power Switch Output. It is the switch node connection to Inductor. This pin connects to the drains of the internal P-ch and N-ch MOSFET switches.
4	VIN	Power supply input pin.
5	FB	Output Voltage Feedback Pin.

ESD RATING

Items	Description	Value	Unit
V _{ESD}	Human Body Model for all pins	±2000	V

JEDEC specification JS-001
RECOMMENDED OPERATING CONDITIONS

Items	Description	Min	Max	Unit
Voltage Range	IN	2.5	6	V
T _J	Operating Junction Temperature Range	-40	125	°C

ELECTRICAL CHARACTERISTICS (Note 3)

($V_{IN}=3.6V$, $V_{OUT}=1.8V$, $T_A=25^{\circ}C$, unless otherwise noted.)

Parameter	Test Conditions	Min	Typ	Max	Unit
Input Voltage Range		2.5		6.0	V
OVP Threshold			6.2	6.5	V
UVLO Rising Threshold			2.3		V
UVLO Hysteresis			300		mV
Quiescent Current	$V_{EN}=2.0V$, $I_{OUT}=0$, $V_{FB}=V_{REF} * 105\%$		40	75	μA
Shutdown Current	$V_{EN}=0V$		0.1	1.0	μA
Regulated Feedback Voltage	$T_A=25^{\circ}C$	0.588	0.600	0.612	V
	$T_A=0^{\circ}C \leq T_A \leq 85^{\circ}C$	0.586	0.600	0.613	V
	$T_A=-40^{\circ}C \leq T_A \leq 85^{\circ}C$	0.585	0.600	0.615	V
Reference Voltage Line Regulation	$V_{IN}=2.5V$ to $5.5V$		0.1		%/V
Output Voltage Accuracy	$V_{IN}=2.5V$ to $5.5V$, $I_{OUT}=10mA$ to $2000mA$	-3		+3	%V
Output Voltage Load Regulation	$I_{OUT}=10mA$ to $2000mA$		0.2		%
Oscillation Frequency	$V_{OUT}=100\%$	0.8	1.0	1.3	MHz
	$V_{OUT}=0V$	200	300	350	kHz
On Resistance of PMOS	$I_{LX}=100mA$		150	190	m Ω
On Resistance of NMOS	$I_{LX}=-100mA$		70	90	m Ω
Peak Current Limit	$V_{IN}=5V$, $V_{OUT}=90\%$		2.5	3.5	A
EN High Level Input Voltage		1.5			V
EN Low Level Input Voltage				0.5	V
EN Leakage Current			± 0.01	± 1.0	μA
LX Leakage Current	$V_{EN}=0V$, $V_{IN}=V_{LX}=5V$		± 0.01	± 1.0	μA

Note 1: Absolute Maximum Ratings are those values beyond which the life of a device may be impaired.

Note 2: T_J is calculated from the ambient temperature T_A and power dissipation P_D according to the following formula: $T_J = T_A + (P_D) \times (250^{\circ}C/W)$.

Note 3: 100% production test at $+25^{\circ}C$. Specifications over the temperature range are guaranteed by design and characterization.

FUNCTION DESCRIPTION

The TMI3411 is a high output current monolithic switch mode step-down DC-DC converter. The device operates at a fixed 1.0MHz switching frequency, and uses a slope compensated current mode architecture.

This step-down DC-DC converter can supply up to 2A output current at $V_{IN} = 5.0V$ and has an input voltage range from 2.5V to 6V. It minimizes external component size and optimizes efficiency at the heavy load range. The slope compensation allows the device to remain stable over a wider range of inductor values so that smaller values ($2.2\mu H$ to $10\mu H$) with lower DCR can be used to achieve higher efficiency. Only a small bypass input capacitor is required at the output.

The adjustable output voltage can be programmed with external feedback to any voltage, ranging from 0.6V to near the input voltage. It uses internal MOSFETs to achieve high efficiency and can generate very low output voltages by using an internal reference of 0.6V. At dropout operation condition, the converter duty cycle increases to 100% and the output voltage tracks the input voltage minus the low $R_{DS(ON)}$ drop of the P-channel high-side MOSFET and the inductor DCR. The internal error amplifier and compensation provides excellent transient response, load and line regulation. Internal soft start eliminates any output voltage overshoot when the enable or the input voltage is applied.

FUNCTIONAL BLOCK DIAGRAM

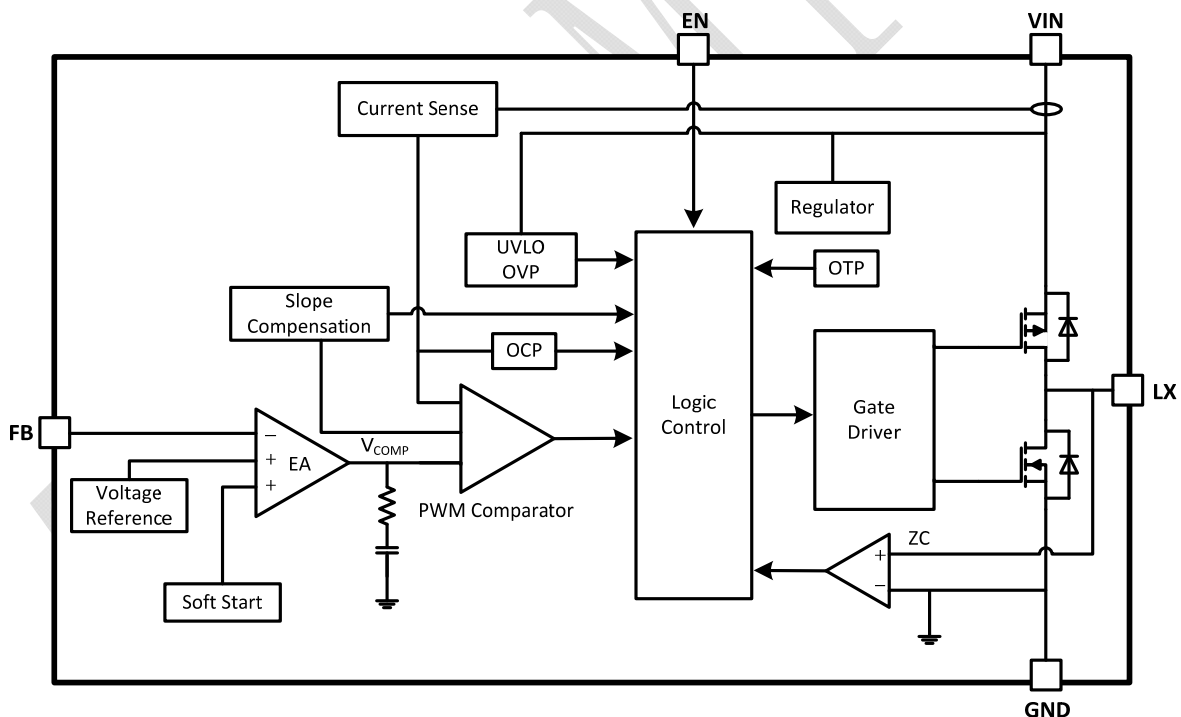

Figure 3. TMI3411 Block Diagram

FUNCTIONAL TEST

Test condition: $V_{IN}=5V$, $V_{OUT}=1.8V$;

1. Load Dynamic Response

10%~90% load

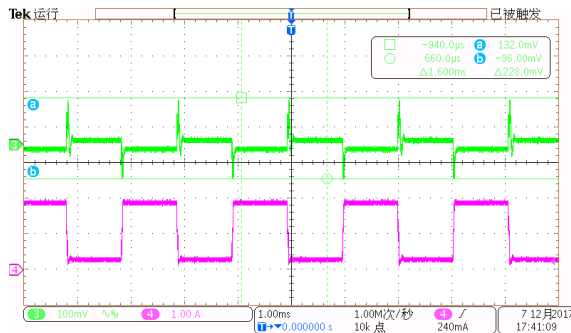

50%~100% load

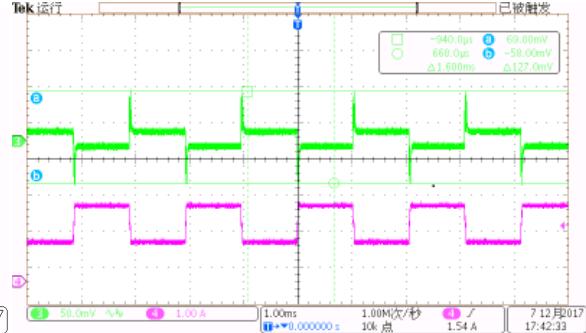

$V_{in}=5V$, $V_{out}=1.8V$ Load transient((0.2A-1.8A-0.2A) $V_{in}=5V$, $V_{out}=1.8V$ Loadtransient((0.2A-1.8A-0.2A)

2. Input/output ripple, Iout=full load

CH1:VIN(AC); CH2:SW; CH3:VOUT(AC); CH4:Isw

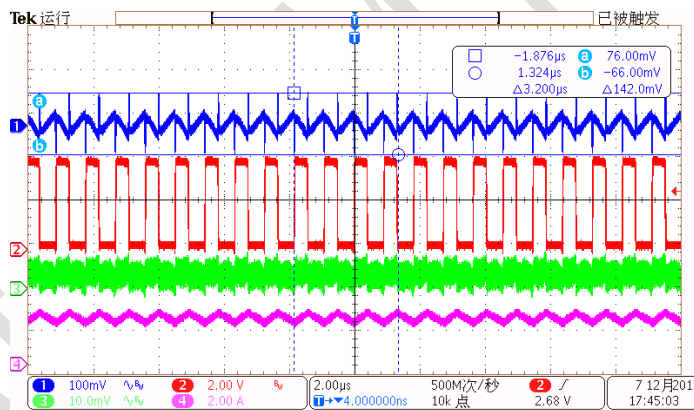

3. Vout ripple and Switching waveform

CH3:VOUT(AC); CH2:SW; CH4:Iout

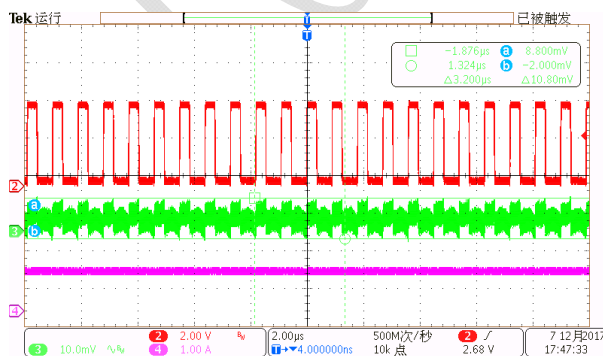

Iout=50% load

CH3:VOUT(AC); CH2:SW; CH4:Iout

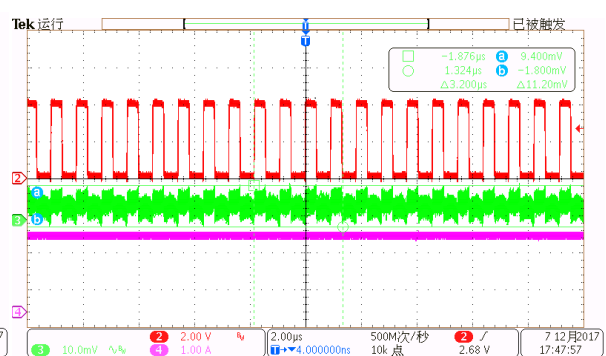

Iout=100% load

4. Power on/off: CH1:VIN;CH2:SW;CH3:VOUT;CH4:lsww

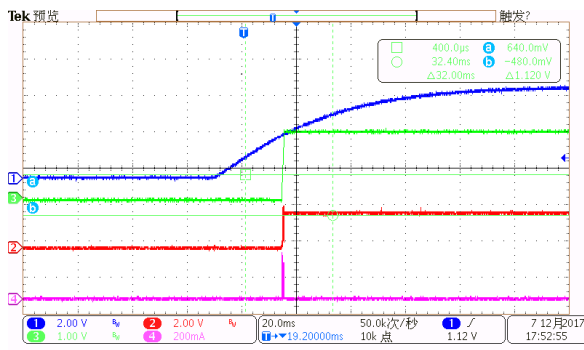

Power on, Iout=0A

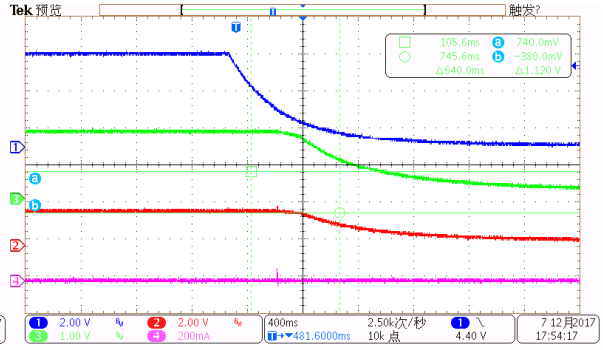

Power off, Iout=0A

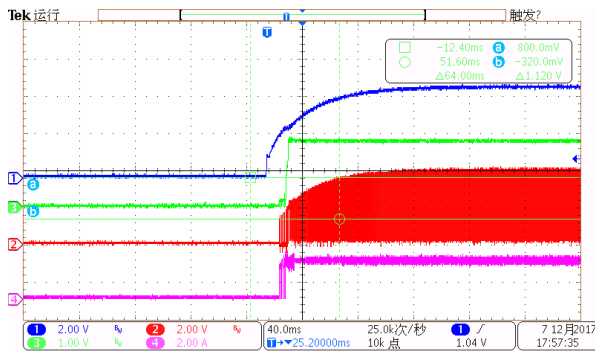

Power on, Iout= 2A

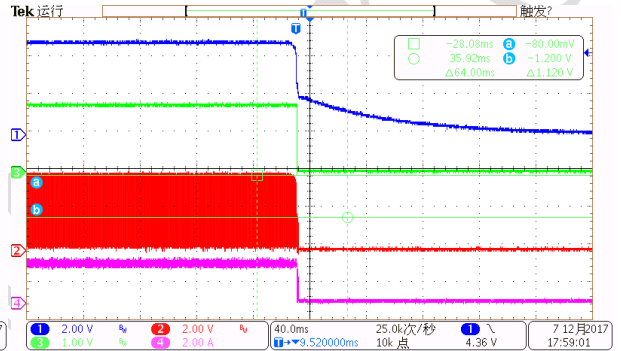

Power off, Iout= 2A

5. EN (5V) on/off:CH1:EN;CH2:SW;CH3:VOUT;CH4:lsww

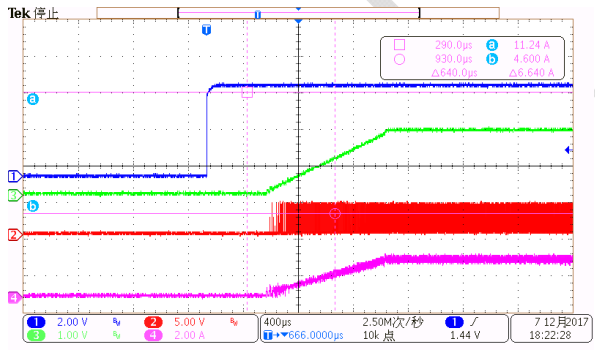

EN on, Iout= 2A

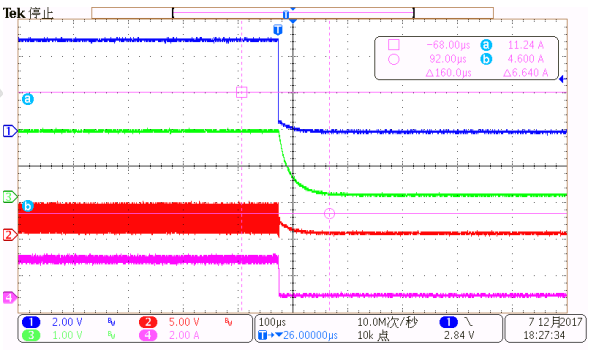

EN off, Iout= 2A

APPLICATION INFORMATION

Setting the Output Voltage

Figure 1 shows the basic application circuit for the TMI3411. The TMI3411 can be externally programmed. Resistors R1 and R2 in Figure 1 program the output to regulate at a voltage higher than 0.6V. To limit the bias current required for the external feedback resistor string while maintaining good noise immunity, the minimum suggested value for R2 is 59kΩ. Although a larger value will further reduce quiescent current, it will also increase the impedance of the feedback node, making it more sensitive to external noise and interference.

The external resistor sets the output voltage according to the following equation:

$$V_{OUT} = 0.6 \times \left(1 + \frac{R_1}{R_2}\right)$$

$$R_1 = (V_{OUT} / 0.6 - 1) \times R_2$$

Inductor Selection

For most designs, the TMI3411 operates with inductors of 1μH to 4.7μH. Low inductance values are physically smaller but require faster switching, which results in some efficiency loss. The inductor value can be derived from the following equation:

$$L = \frac{V_{OUT} \times (V_{IN} - V_{OUT})}{V_{IN} \times \Delta I_L \times f_{OSC}}$$

Where ΔI_L is inductor Ripple Current. Large value inductors result in lower ripple current and small value inductors result in high ripple current. For optimum voltage-positioning load transients, choose an inductor with DC series resistance in the 50mΩ to 150mΩ range.

Input Capacitor Selection

The input capacitor reduces the surge current drawn from the input and switching noise from the device. The input capacitor impedance at the switching frequency should be less than input source impedance to prevent high frequency switching current passing to the input. A low ESR input capacitor sized for maximum RMS current must be used. Ceramic capacitors with X5R or X7R dielectrics are highly recommended because of their low ESR and small temperature coefficients. A 22μF ceramic capacitor for most applications is sufficient. A large value may be used for improved input voltage filtering.

Output Capacitor Selection

The output capacitor is required to keep the output voltage ripple small and to ensure regulation loop stability. The output capacitor must have low impedance at the switching frequency. Ceramic capacitors with X5R or X7R dielectrics are recommended due to their low ESR and high ripple current ratings. The output ripple ΔV_{OUT} is determined by:

$$\Delta V_{OUT} \leq \frac{V_{OUT} \times (V_{IN} - V_{OUT})}{V_{IN} \times f_{OSC} \times L} \times \left(ESR + \frac{1}{8 \times f_{osc} \times C3} \right)$$

A 22μF ceramic can satisfy most applications.

Layout Consideration

When laying out the printed circuit board, the following checking should be used to ensure proper operation of the TMI3411. Check the following in your layout:

1. The power traces, consisting of the GND trace, the LX trace and the VIN trace should be kept short, direct and wide.
2. Does the (+) plates of Cin connect to Vin as closely as possible. This capacitor provides the AC current to the internal power MOSFETs.
3. Keep the switching node, LX, away from the sensitive VOUT node.
4. Keep the (-) plates of Cin and Cout as close as possible

TOLL MICRO

PACKAGE INFORMATION

SOT23-5

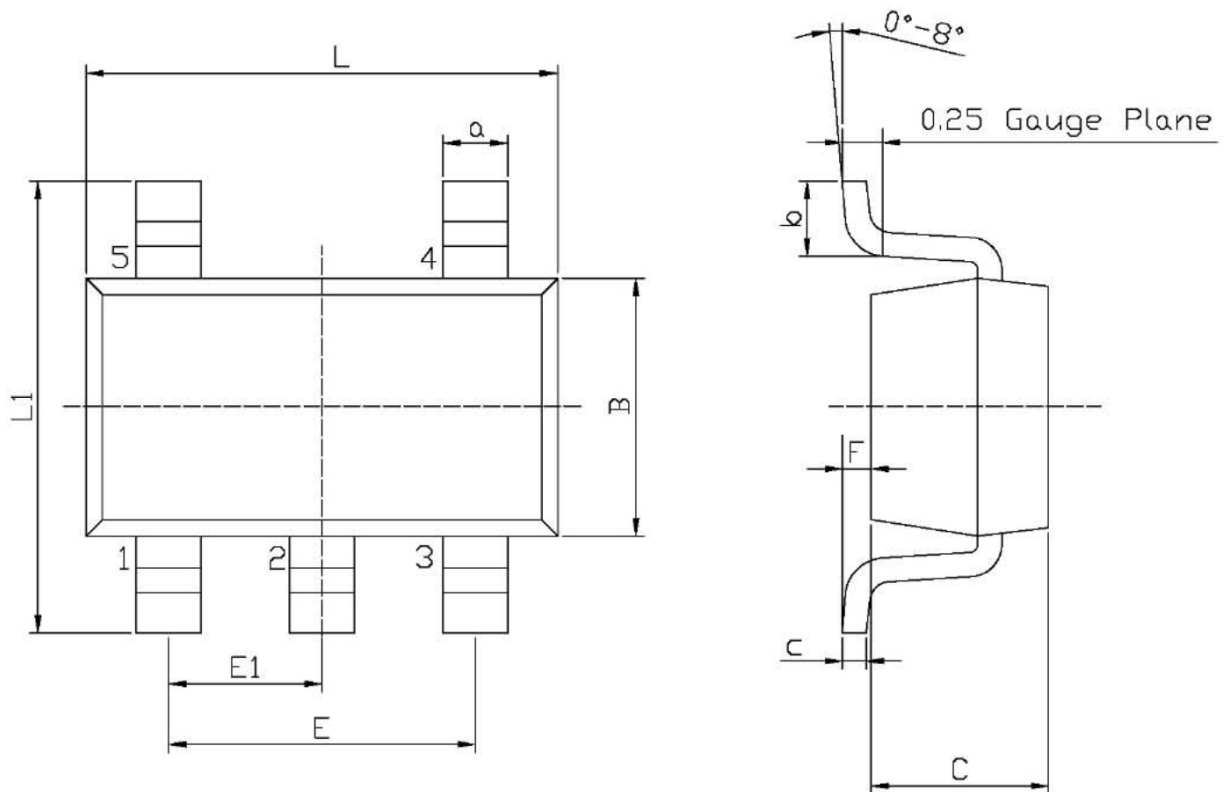

Unit: mm

Symbol	Dimensions In Millimeters		Symbol	Dimensions In Millimeters	
	Min	Max		Min	Max
L	2.82	3.02	E1	0.85	1.05
B	1.50	1.70	a	0.35	0.50
C	0.90	1.30	c	0.10	0.20
L1	2.60	3.00	b	0.35	0.55
E	1.80	2.00	F	0	0.15

Note:

- 1) All dimensions are in millimeters.
- 2) Package length does not include mold flash, protrusion or gate burr.
- 3) Package width does not include inter lead flash or protrusion.
- 4) Lead popularity (bottom of leads after forming) shall be 0.10 millimeters max.
- 5) Pin 1 is lower left pin when reading top mark from left to right.

TAPE AND REEL INFORMATION

TAPE DIMENSIONS:

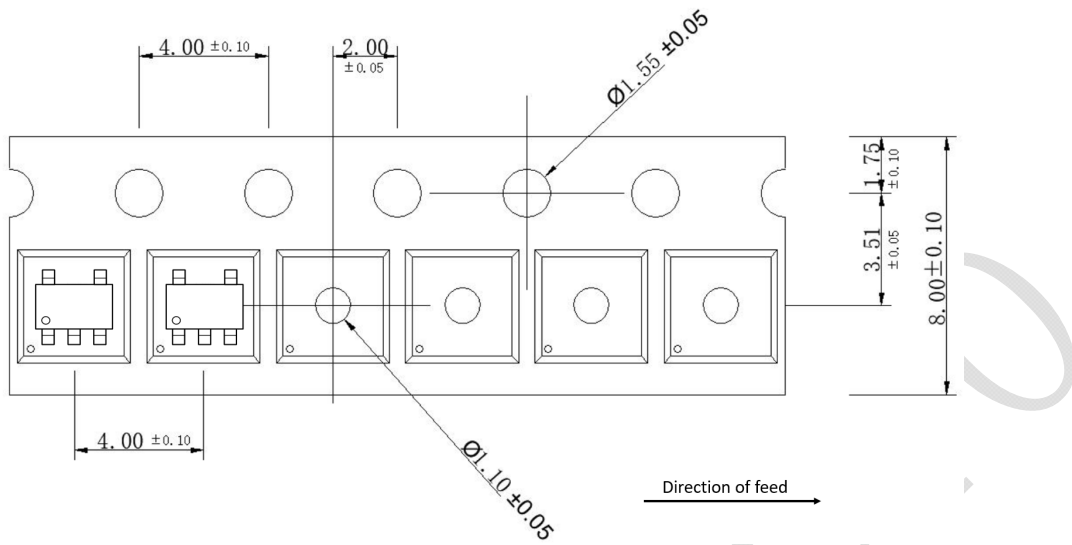

REEL DIMENSIONS:

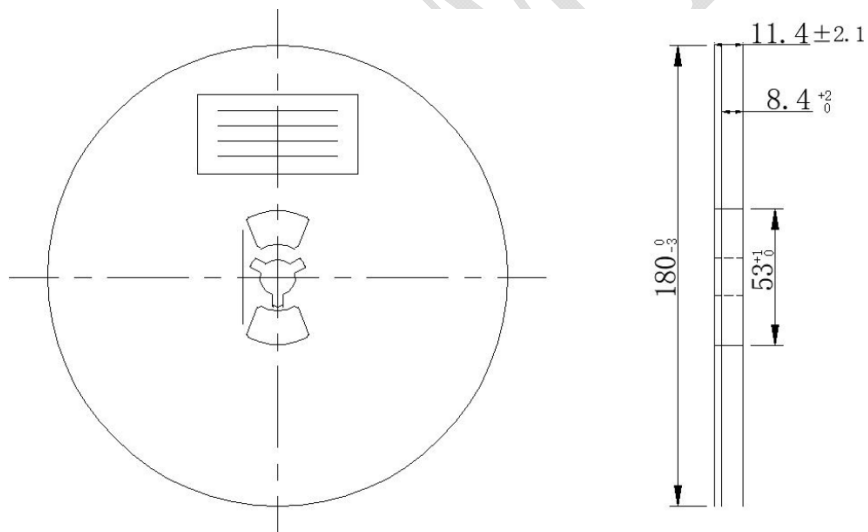

Note:

- 1) All Dimensions are in Millimeter
- 2) Quantity of Units per Reel is 3000
- 3) MSL level is level 3.

单击下面可查看定价，库存，交付和生命周期等信息

[>>TMI](#)