

TMI8340 30V 4A H-Bridge DC Motor Driver

FEATURES

- H-Bridge DC Motor Driver
- 5.0-V to 30-V Operating Supply Voltage Range
- Low Power Standby Mode
- High Output Current Capability
 - SOP8: 4.0-A DC, 8-A Peak
- $R_{\text{dson}}(\text{HS}+\text{LS}): 91\sim 98\text{m}\Omega$
- Protection Features
 - VCC Undervoltage Lockout (UVLO)
 - Overcurrent Protection (OCP)
 - Thermal Shutdown (TSD)
 - Integrated Fast Stop Function
- Package and Footprint:
 - SOP8 (TMI8340SP)

APPLICATIONS

- Electronic locks
- Electric toys
- Massager
- Robots

TYPICAL APPLICATION

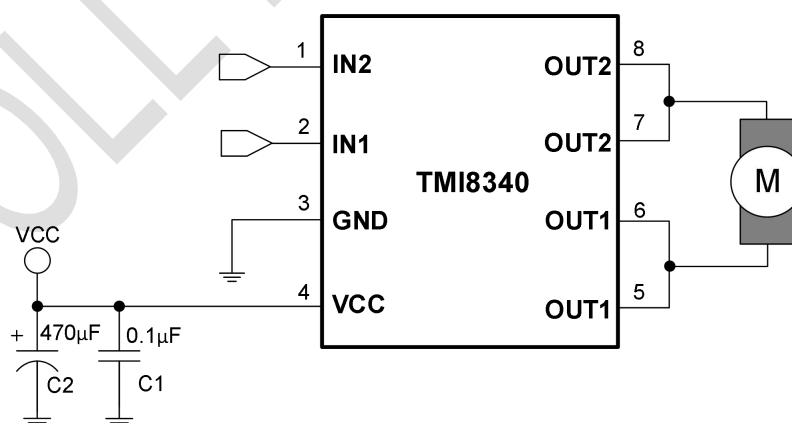

Figure 1. Basic Application Circuit

GENERAL DESCRIPTION

The TMI8340 is a DC bidirectional motor driver, suitable for medium and large current motors.

The two logic input terminals(IN1/IN2) are used as the input of PWM control mode to control the direction of current flow through the H-bridge, and hence the direction of rotation of a DC motor.

This circuit has good anti-interference, tiny standby current, ultra-low output internal resistance, using BCD process, strong withstand voltage, and strong reverse surge current capability to release inductive load.

The package form of TMI8340SP is SOP8, and is comply with ROHS specifications, and the lead frame is 100% lead-free.

ABSOLUTE MAXIMUM RATINGS (Note 1)

Parameter	Value	Unit
Power supply voltage (VCC)	-0.3~30	V
Logic input voltage (IN2, IN1)	-0.3~VCC	V
Output continuous current (I _{OUT}) (SOP8) ^(Note 2)	0~4.0	A
Operating temperature (T _{OP})	-25~85	°C
Power consumption (P _D)	2.5	W
Operating junction temperature ^(Note 3)	-40~150	°C
Storage temperature	-55~150	°C

PACKAGE/ORDER INFORMATION

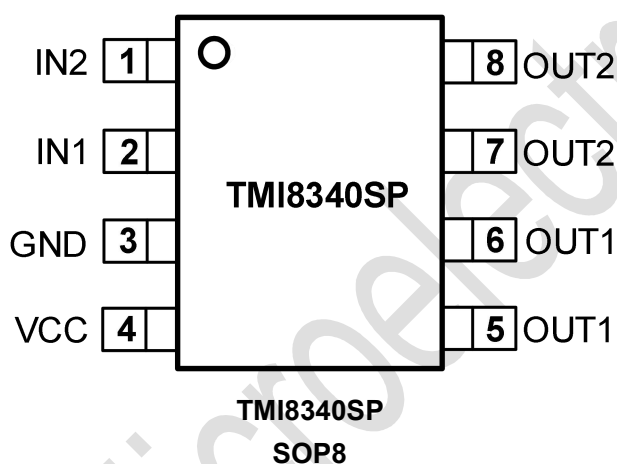

Part Number	Package	Top mark	Quantity/ Reel
TMI8340SP	SOP8	T8340SP XXXXXX	3000

TMI8340SP devices are Pb-free and RoHS compliant.

PIN FUNCTIONS

Pin	Name	I/O	Description
1	IN2	Input	Reverse logic control.
2	IN1	Input	Forward logic control.
3	GND	Ground	Device ground.
4	VCC	Power	Power supply.
5/6	OUT1	Output	Forward output.
7/8	OUT2	Output	Reverse output.

ESD RATING

Items	Description	Value	Unit
V _{ESD}	Human body model for all pins	±2000	V

JEDEC specification JS-001

RECOMMENDED OPERATING CONDITIONS

Parameter	Symbol	Min	Max	Units
Power supply voltage range	VCC	5	30	V
Logic input voltage range	V _{IN_X}	-0.3	6	V
Output continuous current (SOP8)	I _{OUT_X}	0	4	A
Logic input frequency	F _{IN_X}	0	50	kHz

ELECTRICAL CHARACTERISTICS

(T_A = 25°C, over recommended operating conditions unless otherwise noted.)

Parameter	Symbol	Conditions	Min	Typ.	Max	Unit
Power supply (VCC)						
Operation voltage	V _{VCC}		5.0		30	V
Shutdown current	I _{SDT}	VCC=12V, IN1=IN2=0V, no load			1	μA
Standby current	I _{BRAKE}	VCC=12V, IN1=IN2=5V or IN1=5V & IN2=0V or IN1=0V & IN2=5V, no	0.3	0.6	1	mA
PWM current	I _{PWM}	VCC=12V, IN1=5V, IN2=50kHz, no load	1	1.5	3	mA
Undervoltage lockout	UVLO	VCC rising	4.6	4.7	4.9	V
Logic inputs						
Input logic high	V _{INH}		1.5		6	V
Input logic low voltage	V _{INL}				1.2	V
Input logic high	I _{INH}	VCC = 12V, VIN = 5V		50	100	μA
Input logic low current	I _{INL}	VCC = 12V, VIN= 0V			1	μA
H-bridge FETs (SOP8)						
FETs on resistance	R _{ds(on)}	I _{LOAD} =1A, HS+LS		91		mΩ
FETs on resistance	R _{ds(on)}	I _{LOAD} =3A, HS+LS		98		mΩ
Over temperature protection						
Thermal shutdown	T _{OTP}			170		°C
Thermal shutdown hysteresis (Note4)				40		°C
Over current protection						
Overcurrent	I _{OCP}	SOP8		10		
Overcurrent deglitch	t _{OCP}			2.5		μs
Overcurrent retry time	t _{RETRY}			2.4		ms

Note 1: Absolute Maximum Ratings are those values beyond which the life of a device may be impaired.

Note 2: Power dissipation and thermal limits must be observed.

Note 3: T_J is calculated from the ambient temperature T_A and power dissipation P_D according to the following formula: T_J = T_A + P_D × θ_{JA}. The maximum allowable continuous power dissipation at any ambient temperature is calculated by P_{D (MAX)} = (T_{J (MAX)} - T_A) / θ_{JA}.

Note 4: Thermal shutdown threshold and hysteresis are guaranteed by design.

OPERATION

Bridge Control

The TMI8340 output consists of 4 internal P+N channel MOSFETs that are designed to drive high current. These outputs are controlled by the two logic inputs IN1 and IN2 as listed in Table 1.

Table 1. H-Bridge Control

IN1	IN2	OUT1	OUT2	DESCRIPTION
L	L	High-Z	High-Z	Coast; H-bridge disabled to High-Z
L	H	L	H	Reverse (Current OUT2 →OUT1)
H	L	H	L	Forward (Current OUT1 →OUT2)
H	H	L	L	Brake; low-side slow decay

Output Timing Diagram

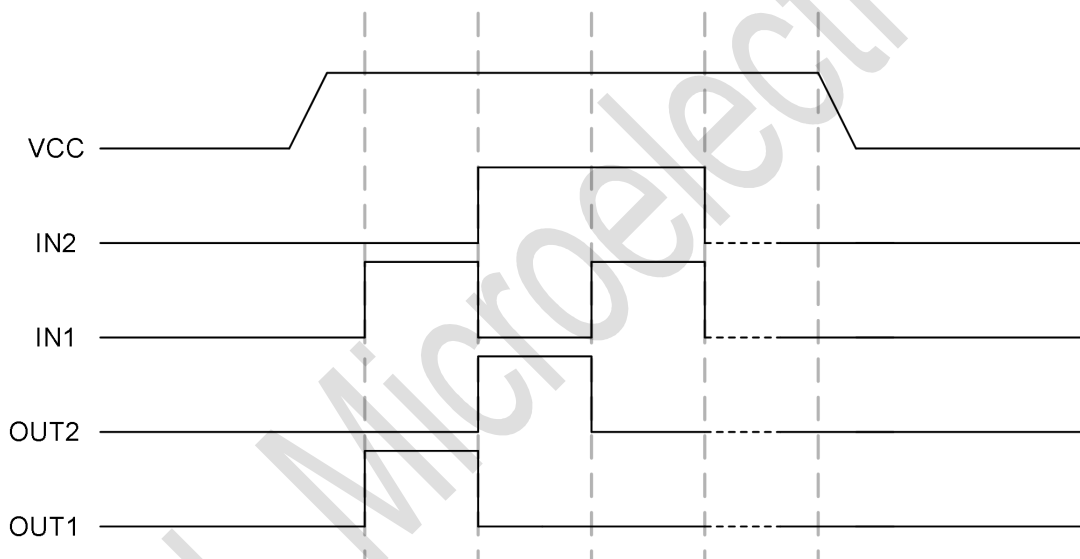

Figure 2. TMI8340 Output Timing Diagram

Application Directions

The peripheral components on the typical application circuit as shown in Figure 1 are described as follows:

C1 and C2 are VCC input capacitors, the main functions are as follows:

1. Absorb the energy released by the motor to the power supply, stabilize the VCC power supply voltage, prevent the IC from being directly broken down due to the high surge voltage, and have the function of filtering ripple and interference noise.
2. At the moment when the motor starts, it can release current to help the motor start quickly.
3. The selection of the VCC input capacitor C2 needs to be based on the voltage stability of the VCC and the motor load current. If the VCC voltage wave is large or the motor load current is large, a larger capacitor value must be selected.
4. C1 and C2 capacitors need to be as close to VCC as possible on the PCB configuration.

Work Mode Directions

Basic working mode:

1. Forward mode, defined as: IN2=L, IN1=H, then OUT2=L, OUT1=H;
2. Reverse mode, defined as: IN2=H, IN1=L, then OUT2=H, OUT1=L;
3. Brake mode, defined as: IN2=H, IN1=H, then OUT2=L, OUT1=L;
4. Coast mode, defined as: IN2=L, IN1=L, at this time OUT2=Open, OUT1=Open.

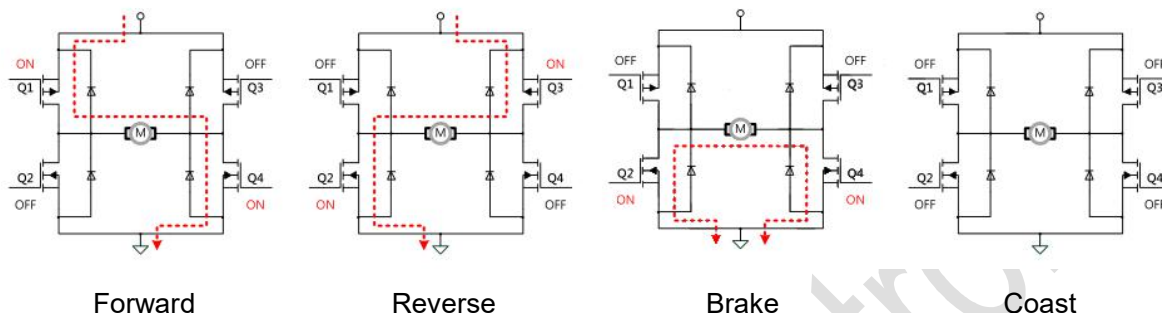

Figure 3. TMI8340SP Work Modes

Thermal Shutdown (TSD) and Over Current Protection (OCP)

When the IC temperature exceeds 170°C (typical value), the overheating protection circuit of the built-in IC will forcibly turn off part of the driving MOS transistors to ensure the safety of customer products.

When the temperature of the IC drops to 130°C (typical), the IC will automatically resume to work quickly.

An analog current limit circuit on each MOSFET limits the peak current out of the device even in hard short circuit events. If the output current exceeds the overcurrent threshold I_{OCP} for longer than t_{OCP} , all MOSFETs in the H-bridge will be disabled for a duration of t_{RETRY} . After t_{RETRY} , the MOSFETs will be re-enabled again.

Block Diagram

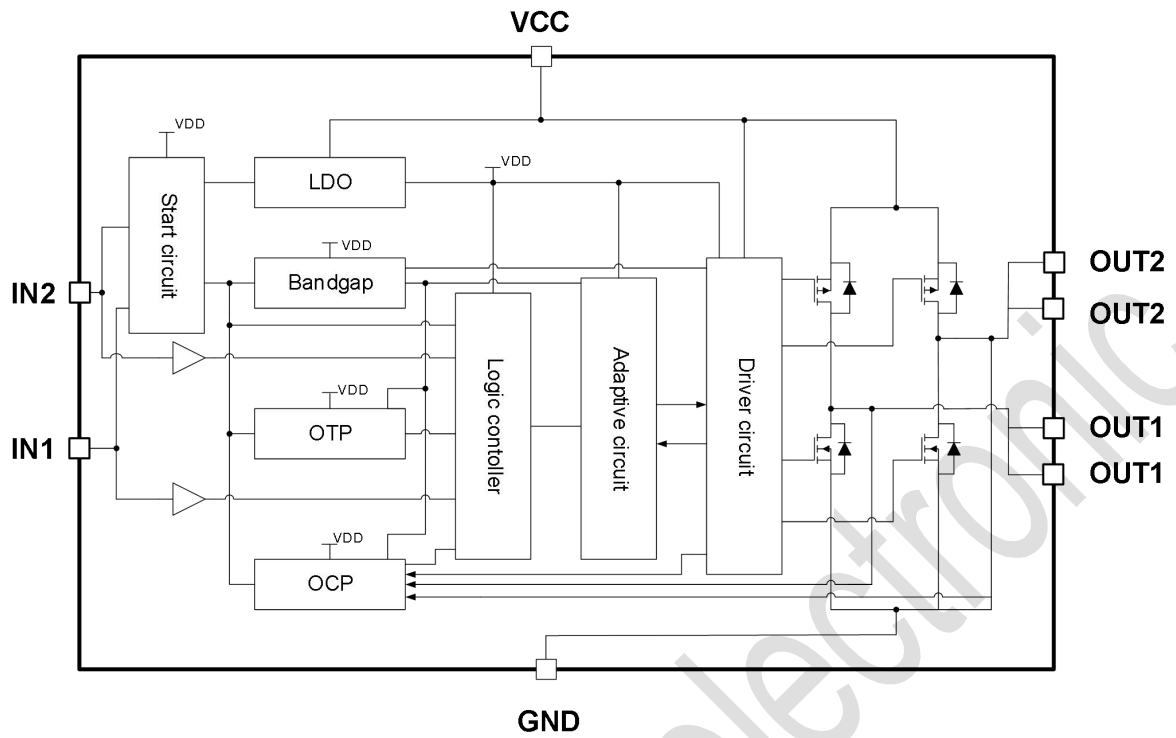
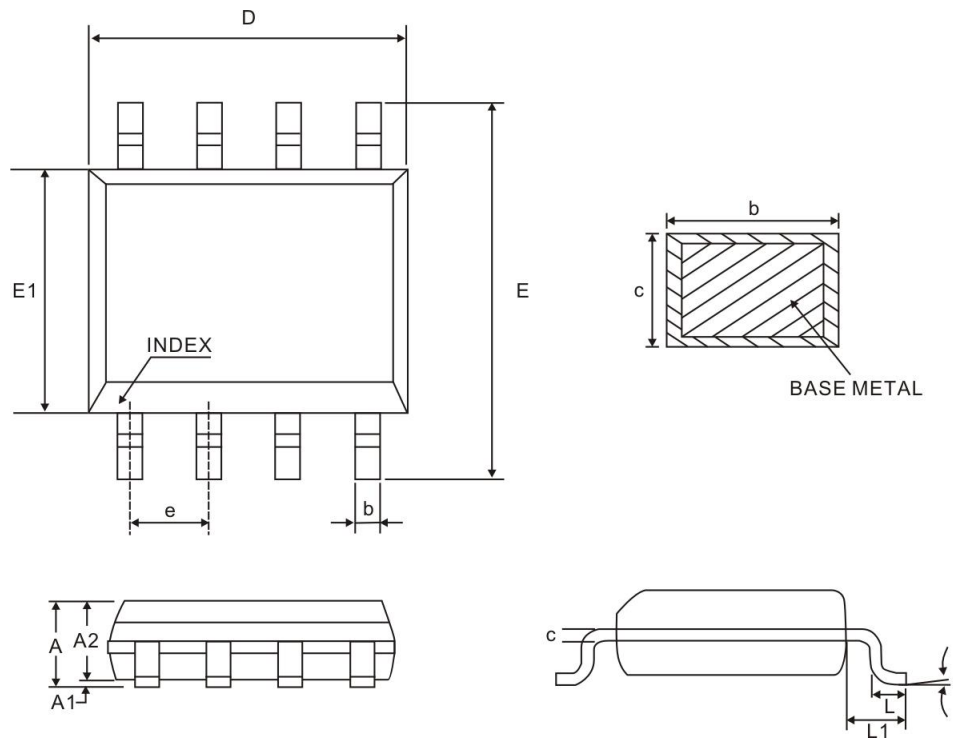

Figure 4. TMI8340 Block Diagram

TOLL Microelectronic

PACKAGE INFORMATION

SOP8



Symbol	Millimeter		
	Min.	Nom.	Max.
A	-	-	1.75
A1	0.10	-	0.25
A2	1.25	-	-
b	0.31	-	0.51
c	0.10	-	0.25
D	4.90 BSC		
E	6.00 BSC		
E1	3.90 BSC		
e	1.27BSC		
L	0.40	-	1.27
θ	0°	-	8°

Notes:

1. Refer to JEDEC MS-012AA
2. All dimensions are in millimeter

单击下面可查看定价，库存，交付和生命周期等信息

[>>TMI](#)