

1.0MHz, 3A Synchronous Step-Down Converter

FEATURES

- High Efficiency: Up to 95%
- 1.0MHz Constant Frequency Operation
- Up to 3A Output Current
- No Schottky Diode Required
- 2.7V to 5.5V Input Voltage Range
- Output Voltage as Low as 0.6V
- PFM Mode for High Efficiency in Light Load
- 100% Duty Cycle in Dropout Operation
- Low Quiescent Current: 50 μ A
- Short Circuit Protection
- Thermal Fault Protection
- Power Good Output Function (TMI3113 only)
- Inrush Current Limit and Soft Start
- Input overvoltage protection (OVP)
- <1 μ A Shutdown Current
- TSOT23-6 package for TMI3113
- SOT23-5 package for TMI3113B

APPLICATIONS

- Cellular and Smart Phones
- Wireless and DSL Modems
- Portable Instruments
- Digital and Video Cameras
- PC Cards

GENERAL DESCRIPTION

The TMI3113 and TMI3113B are 1.0MHz constant frequency, current mode step-down converter. It is ideal for portable equipment requiring high output current up to 3A from single-cell Lithium-ion batteries. They also can run at 100% duty cycle for low dropout operation, extending battery life in portable systems while light load operation provides very low output ripple for noise sensitive applications. The high switching frequency of TMI3113/TMI3113B could minimize the size of external components while keeping switching losses low. The internal slope compensation setting allows the device to operate with smaller inductor values to optimize size and provide efficient operation. TMI3113 has power good function and it is offered in 6 pin, TSOT23-6 package. The TMI3113B is offered in 5-pin, SOT23-5 package with adjustable output voltage without PG pin.

These devices offer two operation modes, PWM control and PFM Mode switching control, which allow a high efficiency over the wider range of the load.

TYPICAL APPLICATION

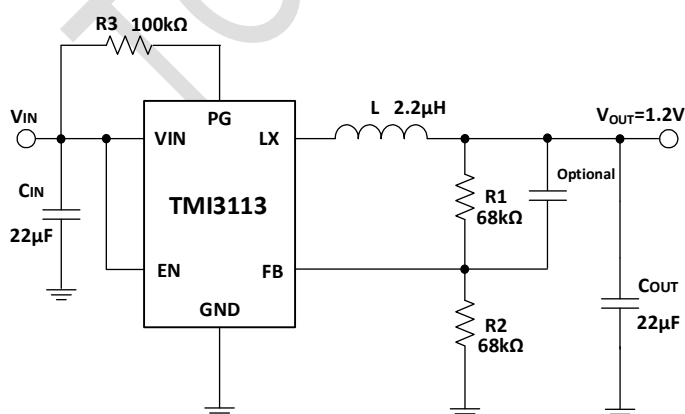

Efficiency

$V_{OUT}=1.2V$, $I_{OUT}=0.01A$ to $3A$, $T_A=25^\circ C$, TMI3113.

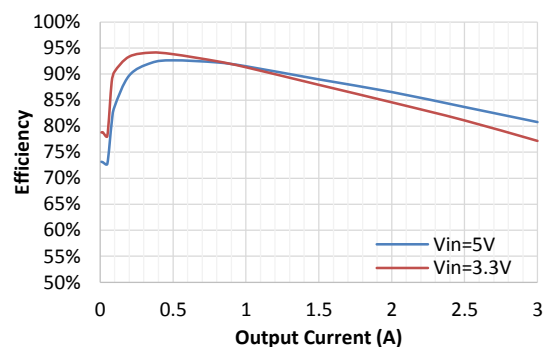

ABSOLUTE MAXIMUM RATINGS (Note 1)

Parameter	Min	Max	Unit
Input Supply Voltage,	-0.3	7	V
LX Voltages	-0.3	7	V
LX Voltage (<10ns transient)	-2.5	7.5	V
LX Voltage (<5ns transient)	-3.5	8.5	V
EN, FB, PG Voltage	-0.3	7	V
Storage Temperature Range	-65	150	°C
Junction Temperature (Note2)	-	160	°C
Power Dissipation (TSOT23-6)	-	1200	mW
Power Dissipation (SOT23-5)	-	1000	mW
Lead Temperature (Soldering,10s)	-	260	°C

PACKAGE/ORDER INFORMATION

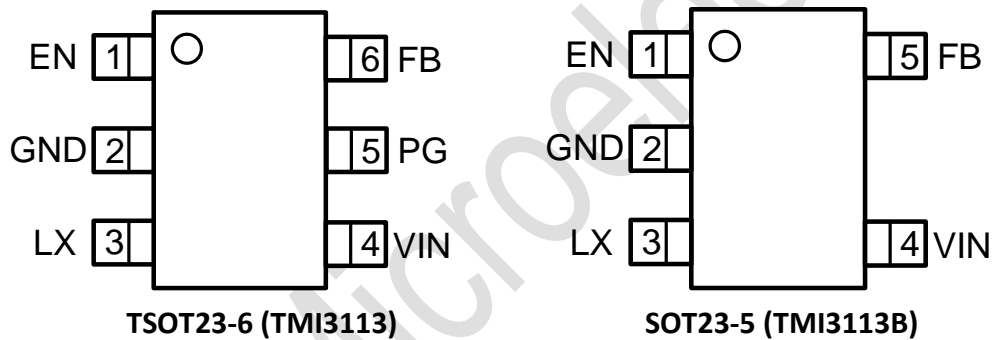

Top Mark: TCBXXX (TCB: Device Code, XXX: Inside Code) For TMI3113
TCCXXX (TCC: Device Code, XXX: Inside Code) For TMI3113B

Part Number	Package	Top mark	Quantity/ Reel
TMI3113	TSOT23-6	TCBXXX	3000
TMI3113B	SOT23-5	TCCXXX	3000

TMI3113 and TMI3113B devices are Pb-free and RoHS compliant.

PIN DESCRIPTIONS

Pin		Name	Function
TMI3113	TMI3113B		
1	1	EN	Enable Pin. Drive EN above 1.5V to turn on the part. Drive EN below 0.4V to turn it off. Do not leave EN floating.
2	2	GND	Ground pin.
3	3	LX	Power Switch Output. It is the switch node connection to Inductor. This pin connects to the drains of the internal P-ch and N-ch MOSFET switches.
4	4	VIN	Analog Supply Input Pin.
5	-	PG	Power Good Open Drain Output Pin for TMI3113.
6	5	FB	Output Voltage Feedback Pin. An internal resistive divider divides the output voltage down for comparison to the internal reference voltage.

ESD RATING

Items	Description	Value	Unit
V _{ESD}	Human Body Model for all pins	±2000	V

JEDEC specification JS-001

RECOMMENDED OPERATING CONDITIONS

Items	Description	Min	Max	Unit
Voltage Range	IN	2.7	5.5	V
T _J	Operating Junction Temperature Range	-40	125	°C
T _A	Operating Ambient Temperature Range	-40	85	°C

THERMAL RESISTANCE

Items	Description	Value	Unit
θ _{JA}	Junction-to-ambient thermal resistance (TSOT23-6)	112	°C/W
θ _{JC}	Junction-to-case(top) thermal resistance (TSOT23-6)	45	°C/W
ψ _{JC}	Junction-to-case(top) characterization parameter (TSOT23-6)	7.5	°C/W
θ _{JA}	Junction-to-ambient thermal resistance (SOT23-5)	135	°C/W
θ _{JC}	Junction-to-case(top) thermal resistance (SOT23-5)	55	°C/W
ψ _{JC}	Junction-to-case(top) characterization parameter (SOT23-5)	12	°C/W

ELECTRICAL CHARACTERISTICS

($V_{IN}=V_{EN}=5V$, $V_{OUT}=1.8V$, $T_A = 25^\circ C$, unless otherwise noted.)

Parameter	Conditions	Min	Typ	Max	Unit
Input Voltage Range		2.7		5.5	V
Input OVP Threshold	V_{IN} Rising		6.1		V
Input UVLO Threshold	V_{IN} Rising	2.35	2.5	2.65	V
Input UVLO Hysteresis		0.4	0.5	0.6	V
Quiescent Current	$V_{EN}=2.0V$, $I_{OUT}=0A$, $V_{FB}=V_{REF} \times 105\%$		50	85	μA
Shutdown Current	$V_{EN} = 0V$		0.1	1.0	μA
Regulated Feedback Voltage V_{FB}	PWM operation, $T_A = 25^\circ C$	0.588	0.600	0.612	V
	PFM operation, No Load, $T_A = 25^\circ C$		0.609		V
Reference Voltage Line Regulation	$V_{IN}=2.7V$ to $5.5V$		0.1		%/V
Output Voltage Accuracy	$V_{IN} = 2.7V$ to $5.5V$, $I_{OUT}=10mA$ to $3000mA$	-3		+3	$\%V_{OUT}$
Oscillation Frequency	$V_{OUT}=100\%$	0.7	1.0	1.3	MHz
	$V_{OUT}=0V$	150	300	450	kHz
On Resistance of PMOS	$I_{LX}=100mA$		95		m Ω
On Resistance of NMOS	$I_{LX}=-100mA$		50		m Ω
Peak Current Limit	$V_{IN}= 5V$, $V_{OUT}=90\%$		3.5		A
EN High Level Input Voltage		1.5			V
EN Low Level Input Voltage				0.4	V
EN Leakage Current				1.0	μA
Power Good Threshold (TMI3113)	Reference to V_{REF} voltage		91%		
Power Good Sink Current (TMI3113)				2	mA
LX Leakage Current	$V_{EN}=0V$, $V_{IN}=V_{LX}=5V$			1.0	μA
Thermal Shutdown Threshold <small>(Note 3)</small>			155		$^\circ C$
Thermal Shutdown Hysteresis <small>(Note 3)</small>			20		$^\circ C$

Note 1: Absolute Maximum Ratings are those values beyond which the life of a device may be impaired.

Note 2: T_j is calculated from the ambient temperature T_A and power dissipation P_D according to the following formula: $T_j = T_A + (P_D) \times \theta_{JA}$.

Note 3: Thermal shutdown threshold and hysteresis are guaranteed by design.

OPERATION

Overview

The TMI3113 and TMI3113B are high output current monolithic switch mode step-down DC-DC converter. The devices operate at a fixed 1.0MHz switching frequency, and uses a slope compensated current mode architecture.

The step-down DC-DC converter can supply up to 3A output current and has an input voltage range from 2.7V to 5.5V. It minimizes external component size and optimizes efficiency at the heavy load range. The slope compensation allows the device to remain stable over a wider range of inductor values so that smaller values with lower DCR can be used to achieve higher efficiency. Only a small bypass input capacitor is required at the output.

In light and no load condition, TMI3113 and TMI3113B are operating in PFM mode for power saving. In PFM mode, the device ramps up its output voltage with several SW switching pulse, while the error amplifier output voltage V_{COMP} drops. The device stops switching when V_{COMP} voltage drops down the inner threshold, so the FB voltage in PFM mode is a little bit higher than normal 0.6V reference voltage in PWM operation. In no load condition, FB voltage is typically 1.5% higher than normal 0.6V reference voltage.

The adjustable output voltage can be programmed with external feedback dividers, ranging from 0.6V to near the input voltage. It uses internal MOSFETs to achieve high efficiency and can generate very low output voltages by using an internal reference of 0.6V. At dropout operation, the converter duty cycle increases to 100% and the output voltage tracks the input voltage minus the low $R_{DS(ON)}$ drop of the P-channel high-side MOSFET and the inductor DCR. The internal error amplifier and compensation provides excellent transient response, load and line regulation. Internal soft start eliminates any output voltage overshoot when the device is enabled or the input voltage is applied.

Input Over Voltage Protection

TMI3113 and TMI3113B have input side over voltage protection function. When input voltage is higher than input OVP threshold 6.1V typical, TMI3113 and TMI3113B stop switching operation to protect device works with high input voltage. When input voltage is recovered from OVP and drops down input OVP threshold with OVP hysteresis typical 180mV, the device starts to switch as normal operation automatically. This function protects device from switching in abnormal high input voltage and input surge condition.

Input Under Voltage Lockout

TMI3113 and TMI3113B implements input under voltage lockout function to avoid mis-operation at low input voltages. When the input voltage is lower than input UVLO threshold with UVLO hysteresis, the device is shut down. The typical 500mV input UVLO hysteresis value of TMI3113 and TMI3113B is useful to prevent device from abnormal switching caused by input voltage oscillation around UVLO threshold during input voltage power-up and power-down with high load condition.

Soft Start

TMI3113 and TMI3113B have built-in soft-start circuits to control output voltage rise rate to avoids excessive inrush current during IC start up. The typical soft-start time is 0.8ms.

Over Current Limit and Output Short Protection

TMI3113 and TMI3113B have high side switching current limit function and prevents the device from high load current condition. The typical high side peak current limit value is 4A. When output load current increases and inductor current peak value reaches peak current limit value, high side MOSFET is turned off immediately and the output voltage drops down according to load condition. If output voltage keeps falling down, once the V_{FB} voltage is lower than 300mV typical, the device enters into output short protection condition. In output short protection condition, the switching frequency of TMI3113 and TMI3113B decreases from 1MHz to 300kHz and the peak current limit value reduces from 4A to 3.6A typically in order to reduce power consumption and device thermal rise in the condition of output short to GND.

Thermal Shutdown

TMI3113 and TMI3113B enter thermal shutdown once the junction temperature exceeds thermal shutdown threshold 155°C typically. Once the device junction temperature falls below the threshold with hysteresis, TMI3113 and TMI3113B return to normal operation automatically.

Power Good

TMI3113 also has power good open drain output to indicate output voltage status. When input voltage is higher than UVLO and EN is enabled, PG status is determined by output voltage. The PG pin goes high impedance when the output is above 91% of regulated nominal voltage and PG pin is pulled low once output voltage falls below the threshold. When the device is shut down by EN pulling low, the PG is pulled low as well.

FUNCTIONAL BLOCK DIAGRAM

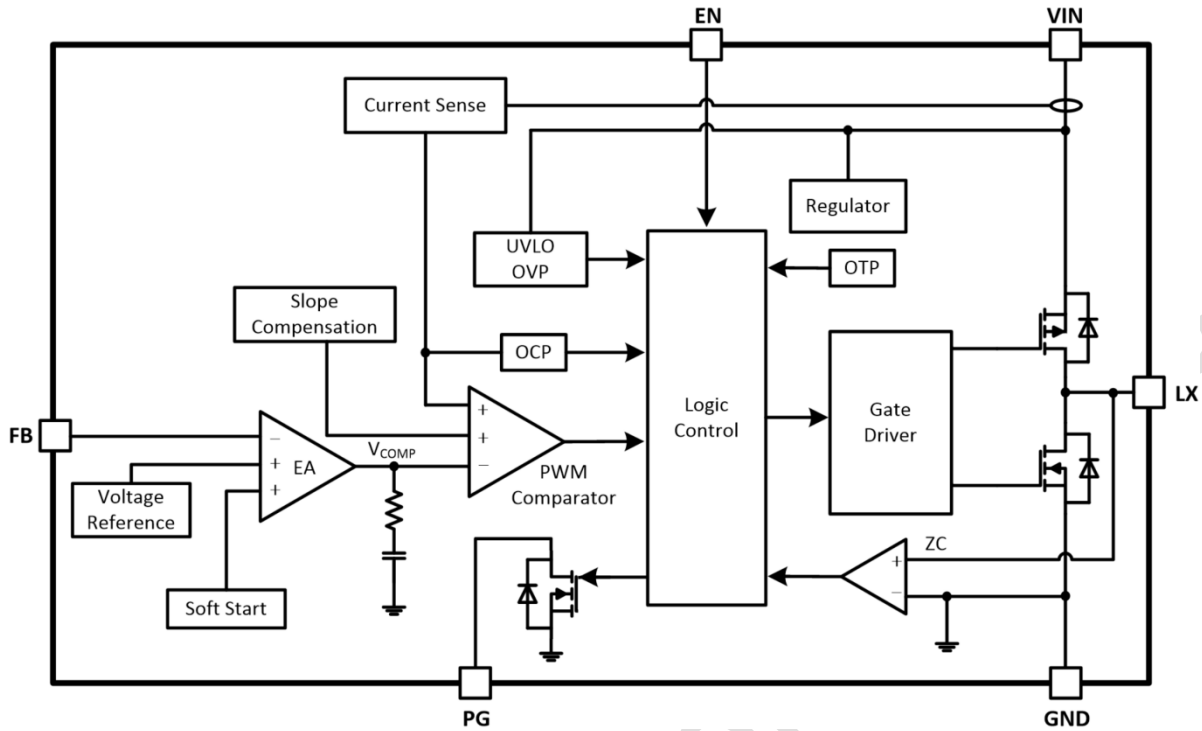

Figure 1. TMI3113 Block Diagram

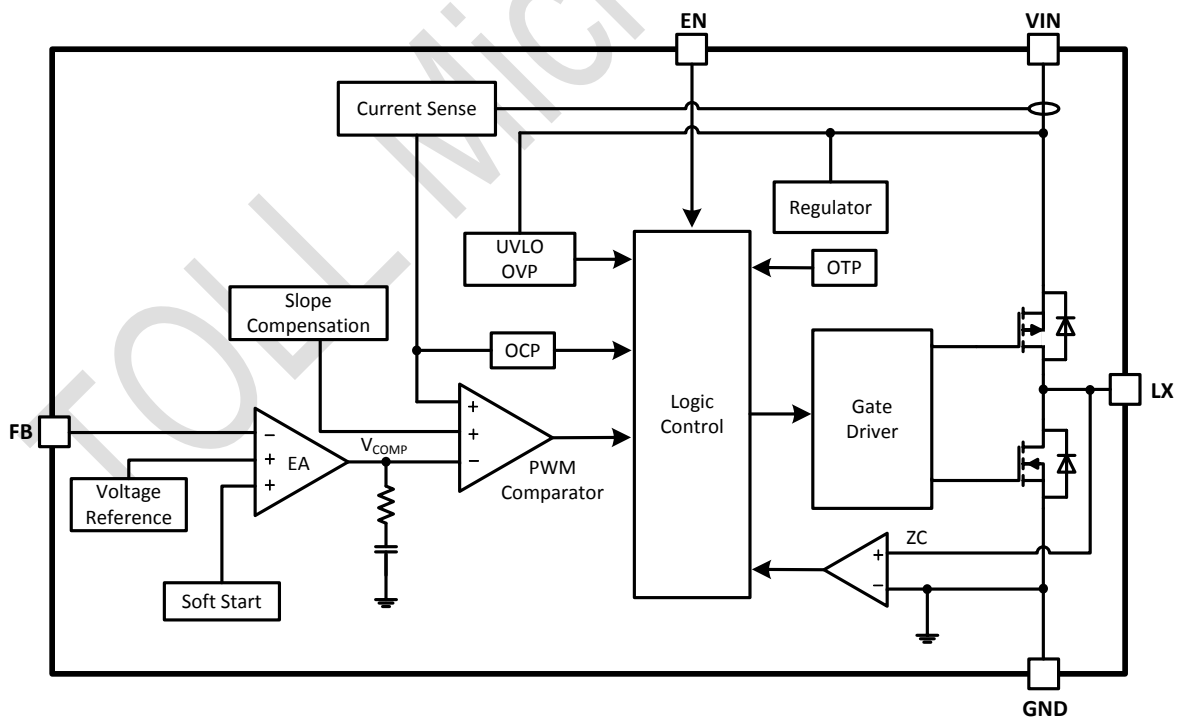

Figure 2. TMI3113B Block Diagram

APPLICATION INFORMATION

Setting the Output Voltage

In the first page, the typical application circuit for the TMI3113/TMI3113B is shown. The output voltage of TMI3113/TMI3113B can be externally programmed. Resistors R1 and R2 in typical application program the output to regulate at a voltage higher than 0.6V.

The external resistor sets the output voltage according to the following equation:

$$V_{OUT} = 0.6 \times \left(1 + \frac{R_1}{R_2}\right)$$

$$R_1 = (V_{OUT} / 0.6 - 1) \times R_2$$

Inductor Selection

For most designs, 2.2μH inductance can satisfy most application conditions. Inductance value is related to inductor ripple current value, input voltage, output voltage setting and switching frequency. The inductor value can be derived from the following equation:

$$L = \frac{V_{OUT} \times (V_{IN} - V_{OUT})}{V_{IN} \times \Delta I_L \times f_{OSC}}$$

Where ΔI_L is inductor ripple current. Large value inductors result in lower ripple current and small value inductors result in high ripple current, so inductor value has effect on output voltage ripple value. DC resistance of inductor which has impact on efficiency of DC/DC converter should be taken into account when selecting the inductor.

Input Capacitor Selection

The input capacitor reduces the surge current drawn from the input and switching noise from the device. The input capacitor impedance at the switching frequency should be less than input source impedance to prevent high frequency switching current passing to the input. A low ESR input capacitor sized for maximum RMS current must be used. Ceramic capacitors with X5R or X7R dielectrics are highly recommended because of their low ESR and small temperature coefficients. A 22μF effective capacitance value ceramic capacitor for most applications is sufficient. A large value of input capacitance may be used for improved input voltage filtering.

Output Capacitor Selection

The output capacitor is required to keep the output voltage ripple small and to ensure regulation loop stability. The output capacitor must have low impedance at the switching frequency. Ceramic capacitors with X5R or X7R dielectrics are recommended due to their low ESR and high ripple current ratings. The output ripple ΔV_{OUT} is determined by:

$$\Delta V_{OUT} \leq \frac{V_{OUT} \times (V_{IN} - V_{OUT})}{V_{IN} \times f_{OSC} \times L} \times \left(ESR + \frac{1}{8 \times f_{osc} \times C3} \right)$$

A 22μF effective capacitance value ceramic capacitor can satisfy most applications. DC voltage derating of ceramic capacitor must be considered in applications, especially for 5V and 3.3V output voltage. A large value of output capacitance is helpful to reduce output ripple during transient load conditions.

Layout Consideration

When laying out the printed circuit board, the following checking should be used to ensure proper operation of the TMI3113/TMI3113B. Check the following in your layout:

1. The power traces, consisting of the GND trace, the LX trace and the VIN trace should be kept short, direct and wide.
2. Does the (+) plates of C_{IN} connect to V_{in} as closely as possible. This capacitor provides the AC current to the internal power MOSFETs.
3. Keep the switching node, LX, away from the sensitive FB node.
4. Keep the (-) plates of C_{IN} and C_{OUT} as close as possible.

TYPICAL PERFORMANCE CHARACTERISTICS

$V_{IN}=5V$, $V_{OUT}=3.3V$, $C_{IN}=22\mu F$, $C_{OUT}=22\mu F$, $L=2.2\mu H$, $T_A=25^\circ C$, TMI3113, unless otherwise noted

Efficiency at $V_{IN} = 5V$

$V_{IN} = 5V$, $L=2.2\mu H$, $DCR=20m\Omega$

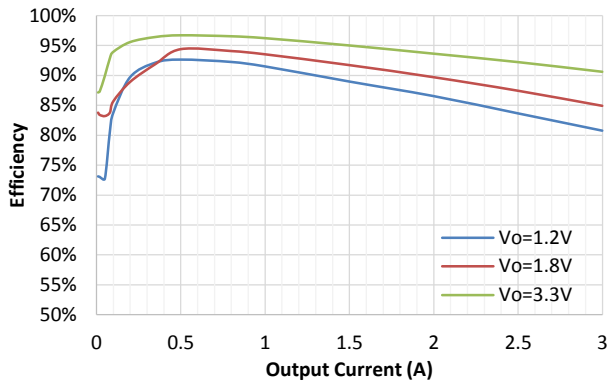

Efficiency at $V_{IN} = 3.3V$

$V_{IN} = 3.3V$, $L=2.2\mu H$, $DCR=20m\Omega$

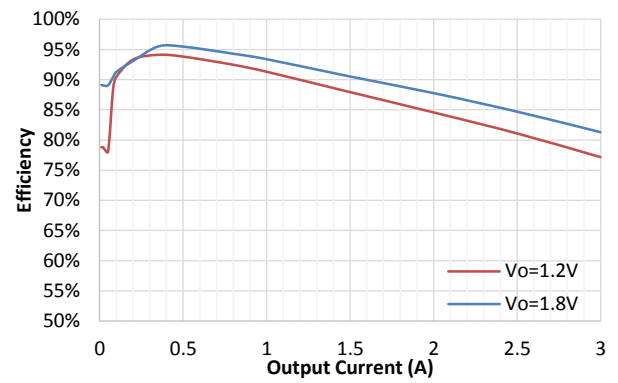

Line Regulation at $V_{OUT}=1.2V$

$V_{OUT}=1.2V$, $T_A=25^\circ C$

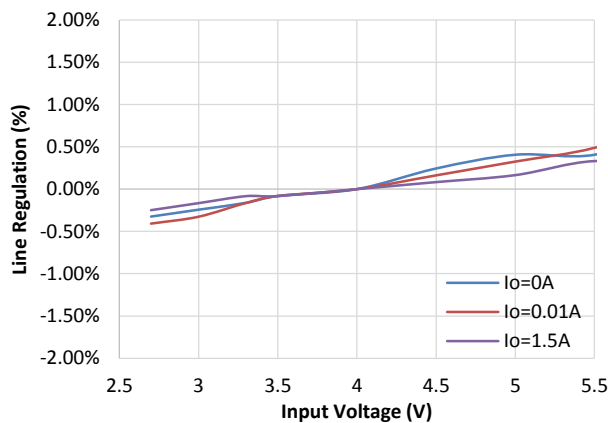

Load Regulation at $V_{IN} = 5V$

$V_{IN}=5V$, $T_A=25^\circ C$

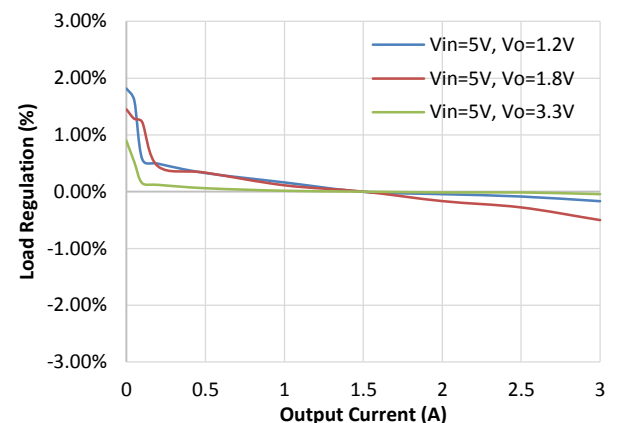

Steady State Operation

$V_{IN} = 5V$, $V_{OUT} = 3.3V$, No Load

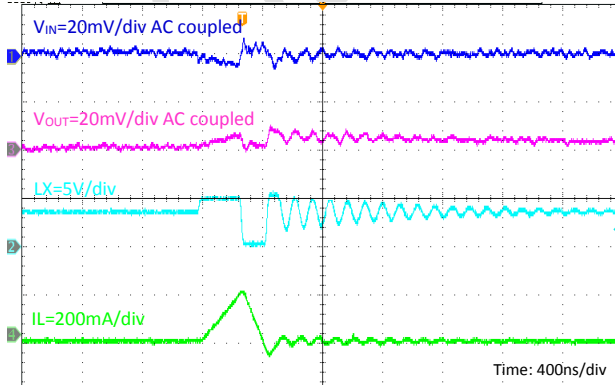

Steady State Operation

$V_{IN} = 5V$, $V_{OUT} = 3.3V$, $I_o=3A$

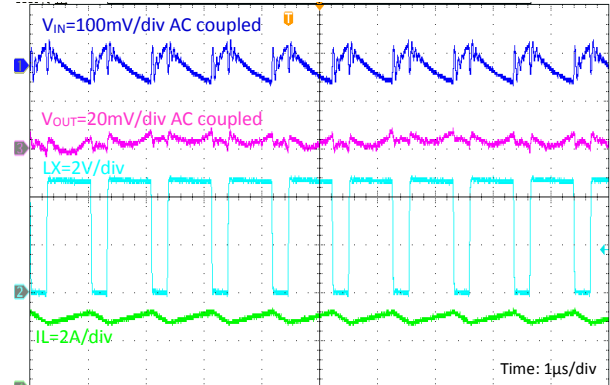

TYPICAL PERFORMANCE CHARACTERISTICS (continued)

Load Transient

$V_{IN} = 5V, V_{OUT} = 3.3V, I_o = 0A \text{ to } 1.5A$

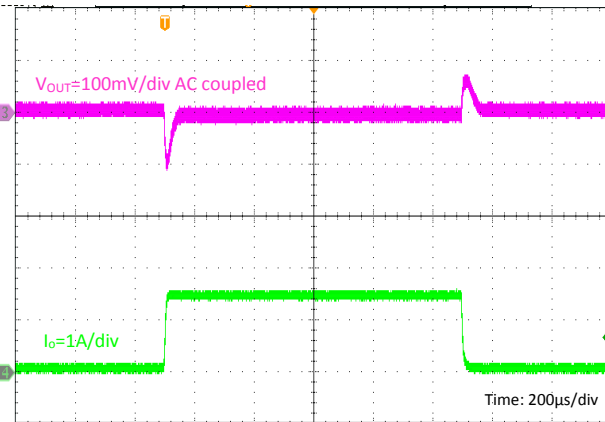

Load Transient

$V_{IN} = 5V, V_{OUT} = 3.3V, I_o = 1.5A \text{ to } 3A$

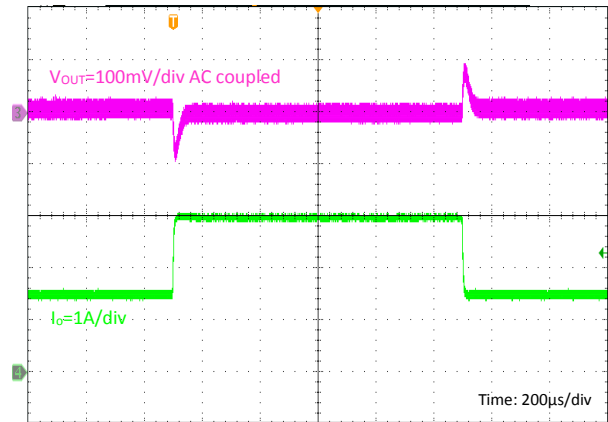

Output Short Entry

$V_{IN} = 5V, V_{OUT} = 3.3V, \text{No Load}$

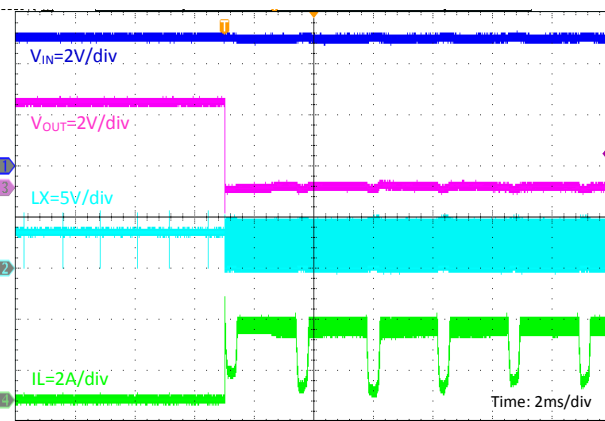

Output Short Recovery

$V_{IN} = 5V, V_{OUT} = 3.3V, \text{No Load}$

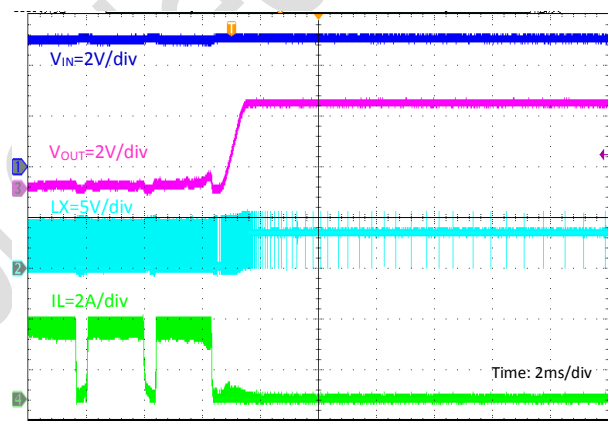

Output Short Entry

$V_{IN} = 5V, V_{OUT} = 3.3V, I_o = 3A$

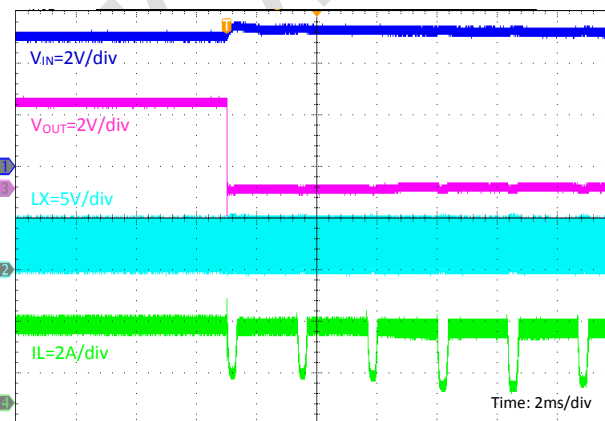

Output Short Recovery

$V_{IN} = 5V, V_{OUT} = 3.3V, I_o = 3A$

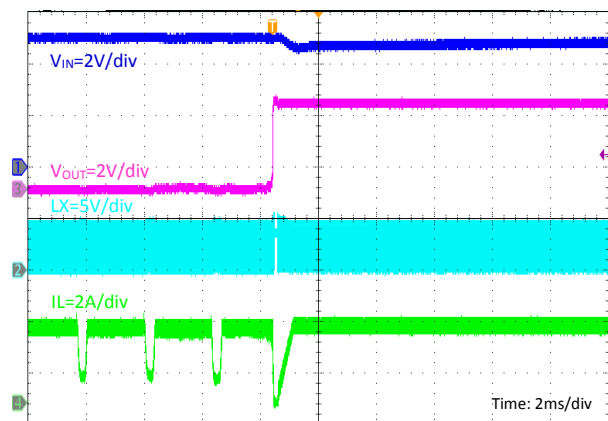

TYPICAL PERFORMANCE CHARACTERISTICS (continued)

EN Enable Power On

$V_{IN} = 5V, V_{OUT} = 3.3V, I_o = 3A$

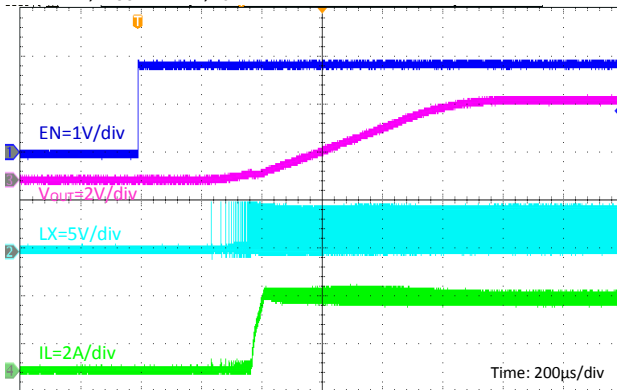

EN Disable Power down

$V_{IN} = 5V, V_{OUT} = 3.3V, I_o = 3A$

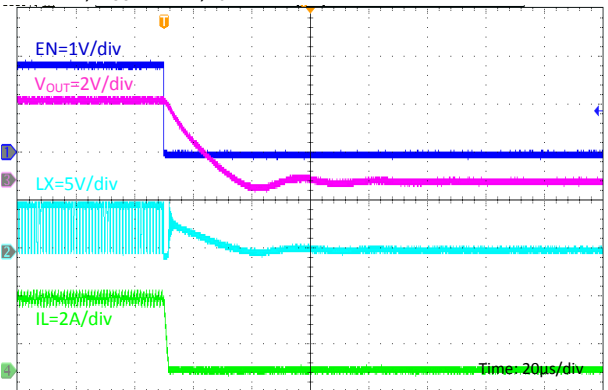

Input Power On

$V_{IN} = 5V, V_{OUT} = 3.3V, \text{No Load}$

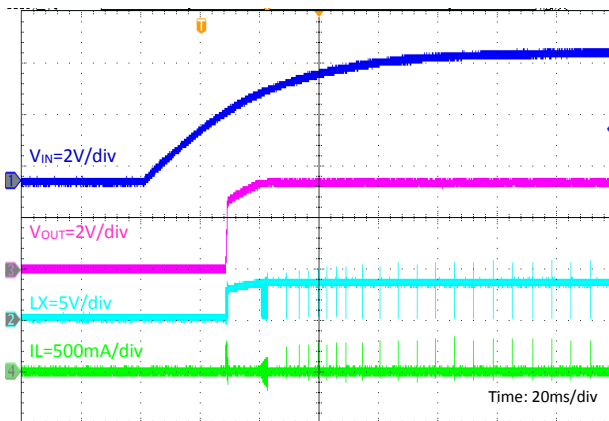

Input Power Down

$V_{IN} = 5V, V_{OUT} = 3.3V, \text{No Load}$

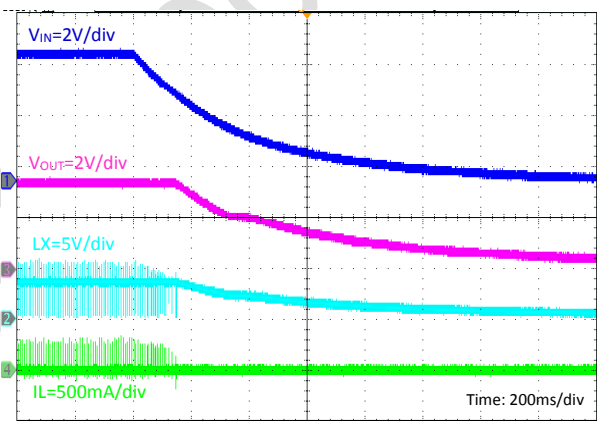

PG when EN Enable

$V_{IN} = 5V, V_{OUT} = 3.3V, I_o = 3A$

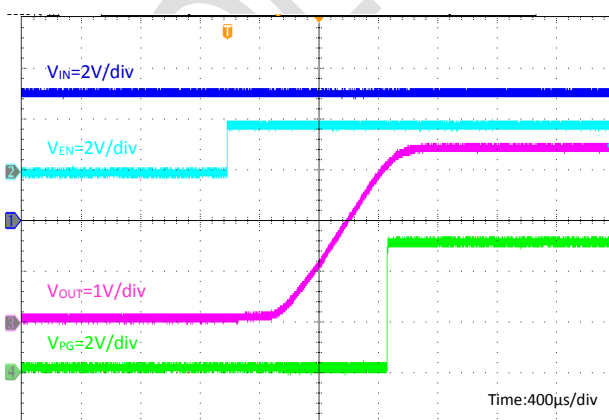

PG when EN Disable

$V_{IN} = 5V, V_{OUT} = 3.3V, I_o = 3A$

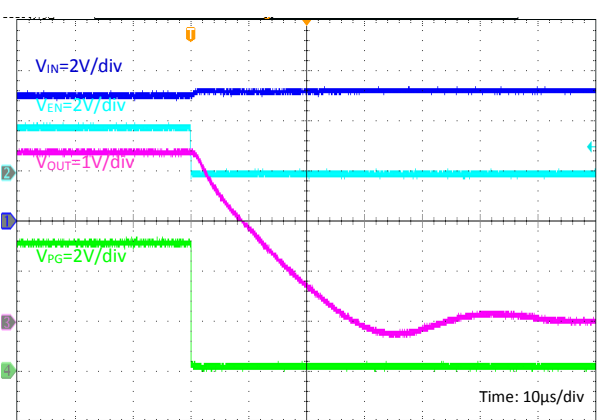

PACKAGE INFORMATION

SOT23-5

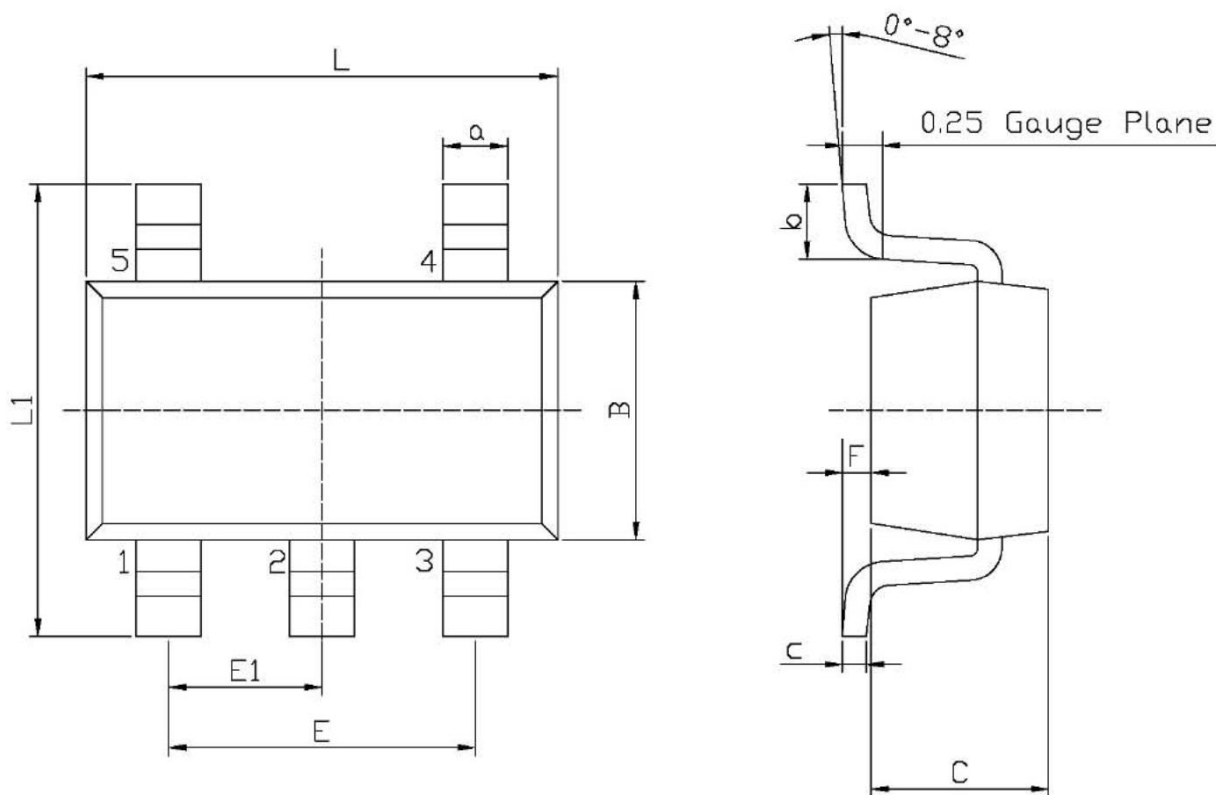

Unit: mm

Symbol	Dimensions In Millimeters		Symbol	Dimensions In Millimeters	
	Min	Max		Min	Max
L	2.82	3.02	E1	0.85	1.05
B	1.50	1.70	a	0.35	0.50
C	0.90	1.30	c	0.10	0.20
L1	2.60	3.00	b	0.35	0.55
E	1.80	2.00	F	0	0.15

Note:

- 1) All dimensions are in millimeters.
- 2) Package length does not include mold flash, protrusion or gate burr.
- 3) Package width does not include interlead flash or protrusion.
- 4) Lead popularity (bottom of leads after forming) shall be 0.10 millimeters max.
- 5) Pin 1 is lower left pin when reading top mark from left to right.

TAPE AND REEL INFORMATION

TAPE DIMENSIONS: SOT23-5

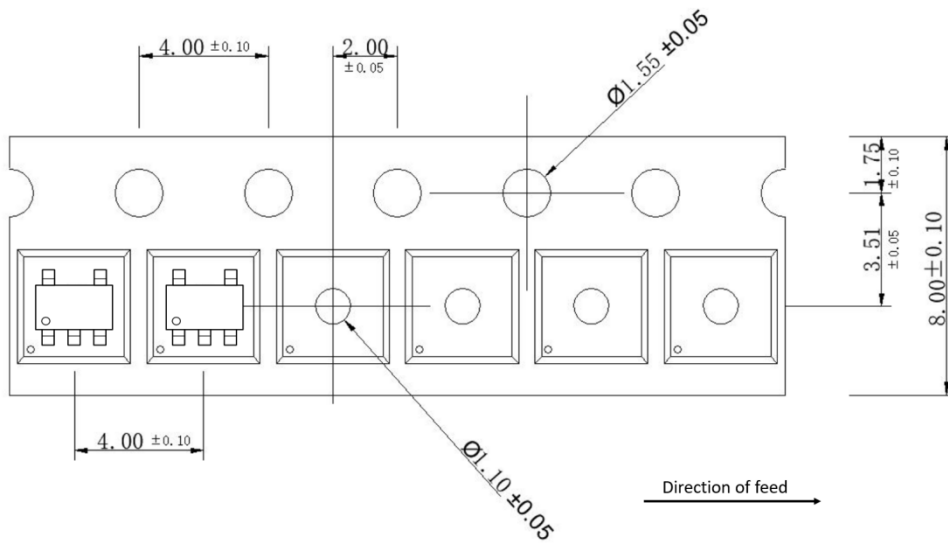

REEL DIMENSIONS: SOT23-5

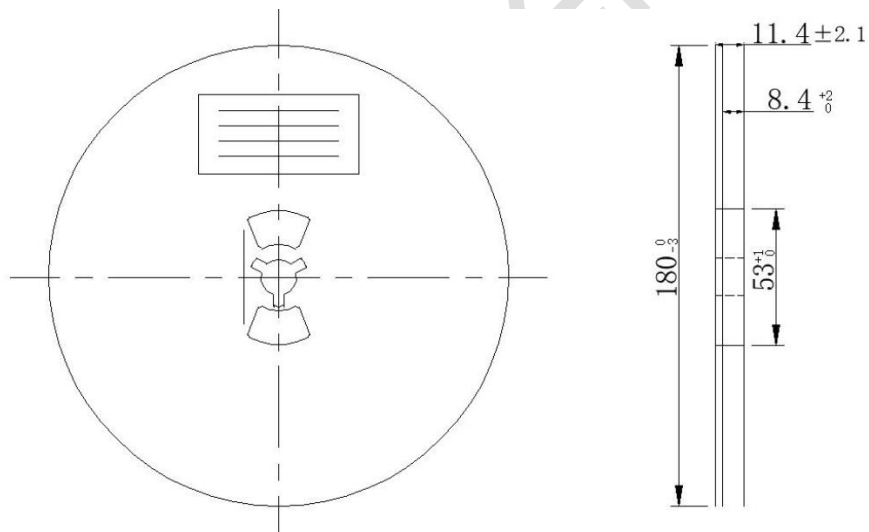

Note:

- 1) All Dimensions are in Millimeter
- 2) Quantity of Units per Reel is 3000
- 3) MSL level is level 3.

PACKAGE INFORMATION

TSOT23-6

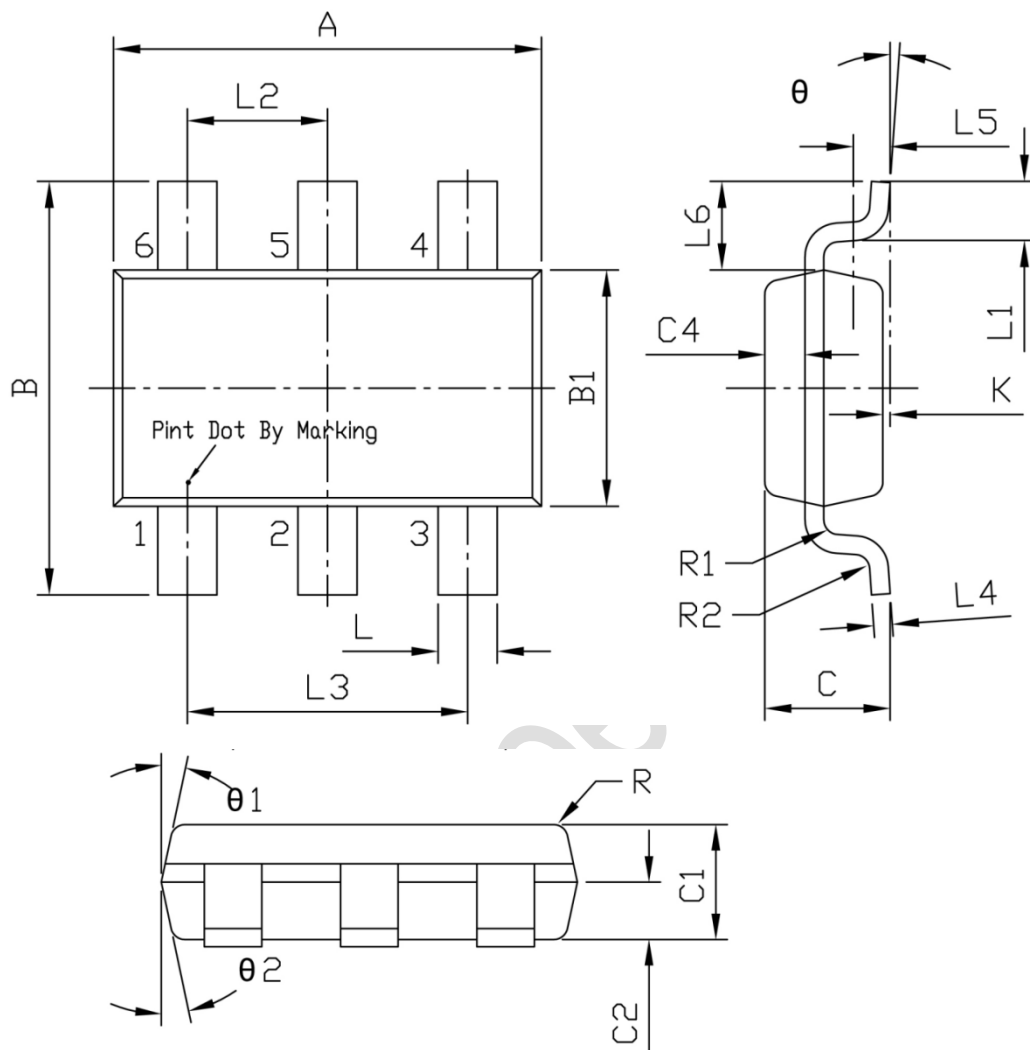

Unit: mm

Symbol	Dimensions In Millimeters			Symbol	Dimensions In Millimeters		
	Min	Typ	Max		Min	Typ	Max
A	2.80	2.90	3.00	L3	1.800	1.900	2.000
B	2.60	2.80	3.00	L4	0.077	0.127	0.177
B1	1.50	1.60	1.70	L5	-	0.250	-
C	-	-	1.05	L6	-	0.600	-
C1	0.60	0.80	1.00	θ	0°		0°
C2	0.35	0.40	0.45	$\theta 1$	10°	12°	14°
C4	0.223	0.273	0.323	$\theta 2$	10°	12°	14°
K	0.000	0.075	0.150	R	-	0.100	-
L	0.325	0.400	0.475	R1	-	0.100	-
L1	0.325	0.450	0.550	R2	-	0.100	-
L2	0.850	0.950	1.050				

TAPE AND REEL INFORMATION

TAPE DIMENSIONS: TSOT23-6

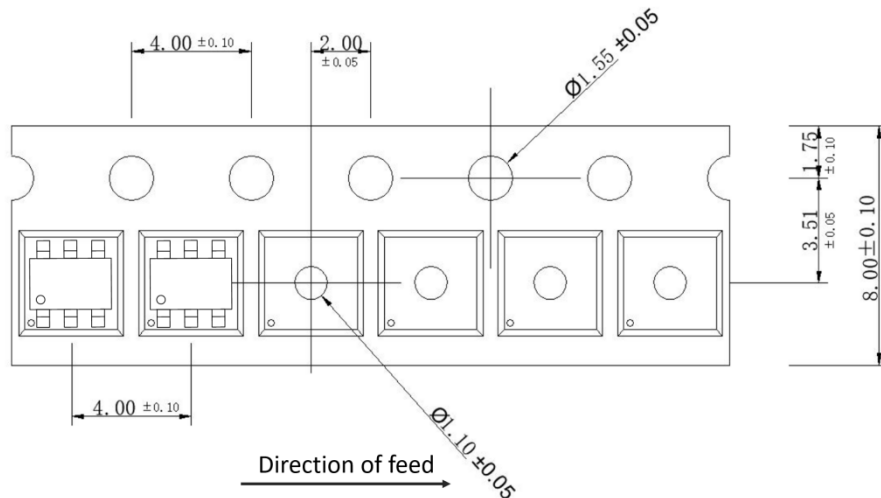

REEL DIMENSIONS: TSOT23-6

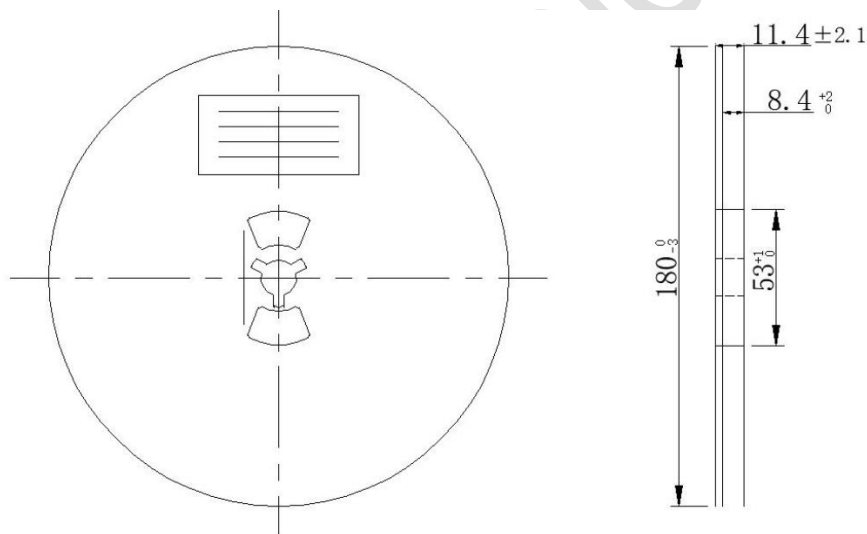

Note:

- 4) All Dimensions are in Millimeter
- 5) Quantity of Units per Reel is 3000
- 6) MSL level is level 3.

单击下面可查看定价，库存，交付和生命周期等信息

[>>TMI](#)