

1.5MHz, 1.2A Synchronous Step-Down Converter

FEATURES

- High Efficiency: Up to 96%
- 1.5MHz Constant Frequency Operation
- 1.2A Output Current
- No Schottky Diode Required
- 2.5V to 6V Input Voltage Range
- Output Voltage as Low as 0.6V
- 100% Duty Cycle in Dropout
- Low Quiescent Current: 40 μ A
- Slope Compensated Current Mode Control for Excellent Line and Load Transient Response
- Short Circuit Protection
- Thermal Fault Protection
- Inrush Current Limit and Soft Start
- Input over voltage protection(OVP)
- <1 μ A Shutdown Current
- DFN2*2-6 Package

GENERAL DESCRIPTION

The TMI3408D is a constant frequency, current mode PWM step-down converter. The device integrates a main switch and a synchronous rectifier for high efficiency without an external Schottky diode. It is ideal for powering portable equipment that runs from a single cell Lithium-Ion (Li+) battery. The output voltage can be regulated as low as 0.6V. The TMI3408D can also run at 100% duty cycle for low dropout operation, extending battery life in portable system. This device offers two operation modes, PWM control and PFM Mode switching control, which allows a high efficiency over the wider range of the load.

APPLICATIONS

- Cellular and Smart Phones
- Wireless and DSL Modems
- PDA/MID/PAD
- Digital Still and Video Cameras

TYPICAL APPLICATION

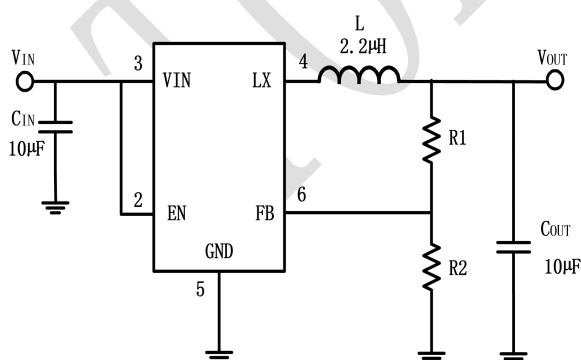

Figure 1. Basic Application Circuit

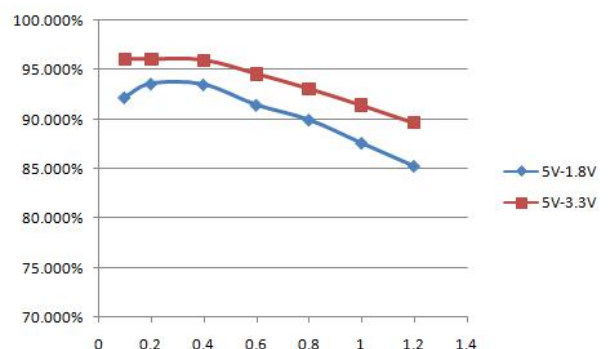
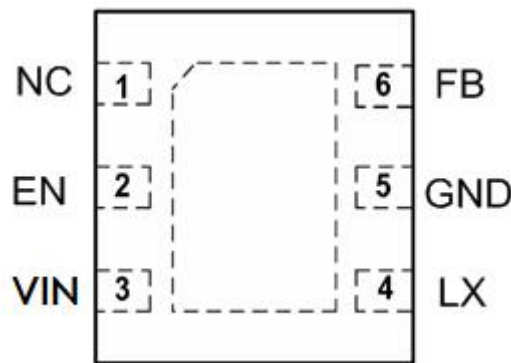

Figure 2. Efficiency(%) vs. Load Current(A)

ABSOLUTE MAXIMUM RATINGS (Note 1)

Parameter	Value	Unit
Input Supply Voltage	-0.3~6.5	V
LX Voltages	-0.3~6.5	V
EN,FB Voltage	-0.3~6.5	V
Storage Temperature Range	-65~150	°C
Junction Temperature(Note2)	155	°C
Lead Temperature(Soldering,10s)	260	°C

PACKAGE/ORDER INFORMATION



DFN2*2-6

Top Mark: T25XXX (T25: Device Code, XXX: Inside Code)

Part Number	Package	Top mark	Quantity/ Reel
TMI3408D	DFN2*2-6	T25XXX	3000

PIN DESCRIPTION

Pin	Name	Function
1	NC	Not connected
2	EN	Chip Enable Pin. Drive EN above 1.5V to turn on the part. Drive EN below 0.3V to turn it off. Do not leave EN floating.
3	VIN	Power Supply Input. Must be closely decoupled to GND with a 10 μ F or greater ceramic capacitor.
4	LX	Power Switch Output. It is the switch node connection to Inductor.
5	GND	Ground Pin
6	FB	Output Voltage Feedback Pin.

ESD RATING

Items	Description	Value	Unit
V _{ESD}	Human Body Model for all pins	\pm 2000	V

JEDEC specification JS-001

RECOMMENDED OPERATING CONDITIONS

Items	Description	Min	Max	Unit
Voltage Range	IN	2.5	6.0	V
TA	Operating Temperature Range	-40	85	$^{\circ}$ C

ELECTRICAL CHARACTERISTICS (Note 3)

($V_{IN}=V_{EN}=3.6V$, $V_{OUT}=1.8V$, $T_A = 25^{\circ}C$, unless otherwise noted.)

Parameter	Conditions	Min	Typ	Max	Unit
Input Voltage Range		2.5		6.0	V
OVP Threshold			6.0		V
UVLO Threshold			2.3		V
Input DC Supply Current	(Note 4)				μA
PWM Mode	$V_{OUT} = 90\%$, $I_{LOAD}=0mA$		140	300	μA
PFM Mode	$V_{OUT} = 105\%$, $I_{LOAD}=0mA$		40	65	μA
Shutdown Mode	$V_{EN} = 0V$, $V_{IN}=4.2V$		0.1	1.0	μA
Regulated Feedback Voltage	$T_A = 25^{\circ}C$	0.588	0.600	0.612	V
	$T_A = 0^{\circ}C \leq T_A \leq 85^{\circ}C$	0.586	0.600	0.613	V
	$T_A = -40^{\circ}C \leq T_A \leq 85^{\circ}C$	0.585	0.600	0.615	V
Reference Voltage Line Regulation	$V_{IN}=2.5V$ to $6.0V$		0.04	0.40	%/V
Output Voltage Line Regulation	$V_{IN} = 2.5V$ to $6.0V$		0.04	0.4	%
Output Voltage Load Regulation			0.5		%
Oscillation Frequency	$V_{OUT}=100\%$		1.5		MHz
	$V_{OUT}=0V$		300		KHz
On Resistance of PMOS	$I_{LX}=100mA$		0.25	0.30	Ω
ON Resistance of NMOS	$I_{LX}=-100mA$		0.10	0.15	Ω
Peak Current Limit	$V_{IN}=5V, V_{OUT}=1.2V, L=4.7\mu H/2A$	1.2			A
RUN Threshold		0.30	1.0	1.50	V
RUN Leakage Current			± 0.01	± 1.0	μA
LX Leakage Current	$V_{EN}=0V, V_{IN}=V_{LX}=5V$		± 0.01	± 1.0	μA

Note 1: Absolute Maximum Ratings are those values beyond which the life of a device may be impaired.

Note 2: T_j is calculated from the ambient temperature T_A and power dissipation P_D

Note 3: 100% production test at $+25^{\circ}C$. Specifications over the temperature range are guaranteed by design and characterization.

Note 4: Dynamic supply current is higher due to the gate charge being delivered at the switching frequency

FUNCTIONAL DESCRIPTION

The TMI3408D is a high performance 1.2A 1.5MHz monolithic step-down converter. The TMI3408D requires only three external power components (C_{in}, C_{out} and L). The adjustable version can be programmed with external feedback to any voltage, ranging from 0.6V to the input voltage.

At dropout, the converter duty cycle increases to 100% and the output voltage tracks the input voltage minus the R_{ds(on)} drop of the high-side MOSFET.

The internal error amplifier and compensation provides excellent transient response, load, and line regulation. Soft start function prevents input inrush current and output overshoot during start up.

FUNCTIONAL BLOCK DIAGRAM

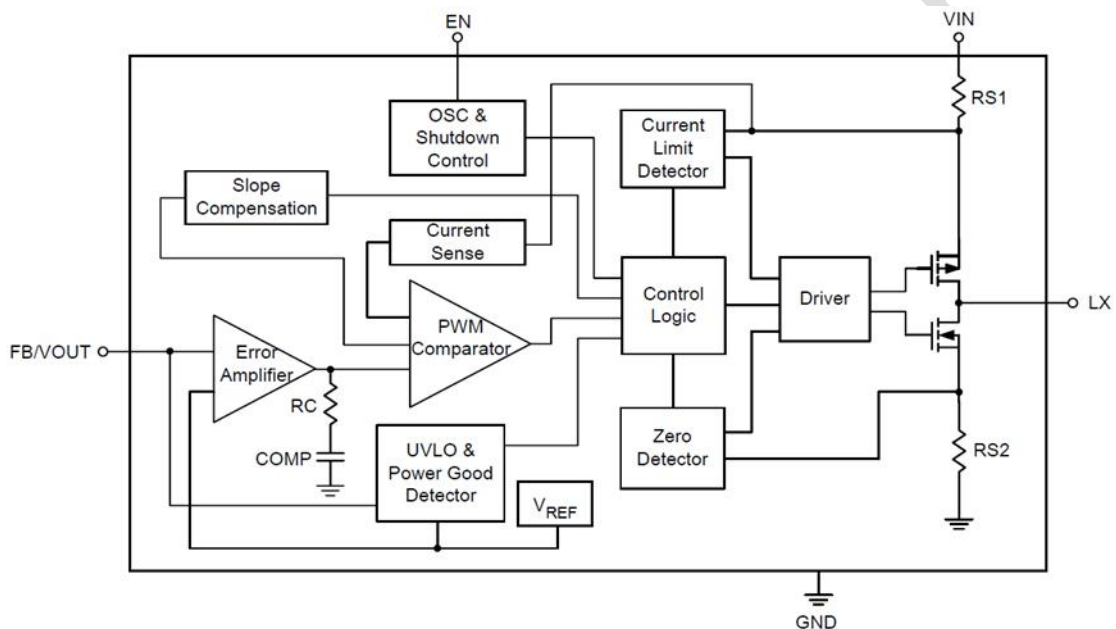

Figure 3. TMI3408D Block Diagram

APPLICATION INFORMATION

Setting the Output Voltage

Figure 1 shows the basic application circuit for the TMI3408D. The TMI3408D can be externally programmed. Resistors R1 and R2 in Figure 1 program the output to regulate at a voltage higher than 0.6V. To limit the bias current required for the external feedback resistor string while maintaining good noise immunity, the minimum suggested value for R2 is 59kΩ. Although a larger value will further reduce quiescent current, it will also increase the impedance of the feedback node, making it more sensitive to external noise and interference. The external resistor sets the output voltage according to the following equation:

$$V_{OUT} = 0.6 \times \left(1 + \frac{R_1}{R_2}\right) \quad R_1 = (V_{OUT} / 0.6 - 1) \times R_2$$

Inductor Selection

For most designs, the TMI3408D operates with inductors of 2.2μH to 10μH. Low inductance values are physically smaller but require faster switching, which results in some efficiency loss. The inductor value can be derived from the following equation:

$$L = \frac{V_{OUT} \times (V_{IN} - V_{OUT})}{V_{IN} \times \Delta I_L \times f_{OSC}}$$

Where ΔI_L is inductor Ripple Current. Large value inductors result in lower ripple current and small value inductors result in high ripple current. For optimum voltage-positioning load transients, choose an inductor with DC series resistance in the 50mΩ to 150mΩ range.

Input Capacitor Selection

The input capacitor reduces the surge current drawn from the input and switching noise from the device.

The input capacitor impedance at the switching frequency should be less than input source impedance to prevent high frequency switching current passing to the input.

A low ESR input capacitor sized for maximum RMS current must be used. Ceramic capacitors with X5R or X7R dielectrics are highly recommended because of their low ESR and small temperature coefficients.

A 10μF ceramic capacitor for most applications is sufficient. A large value may be used for improved input voltage filtering.

Output Capacitor Selection

The output capacitor is required to keep the output voltage ripple small and to ensure regulation loop stability. The output capacitor must have low impedance at the switching frequency. Ceramic capacitors with X5R or X7R dielectrics are recommended due to their low ESR and high ripple current ratings. The output ripple V_{OUT} is determined by:

$$\Delta V_{OUT} \leq \frac{V_{OUT} \times (V_{IN} - V_{OUT})}{V_{IN} \times f_{OSC} \times L} \times \left(ESR + \frac{1}{8 \times f_{osc} \times C3} \right)$$

A 10 μ F ceramic can satisfy most applications.

Layout Consideration

When laying out the printed circuit board, the following checking should be used to ensure proper operation of the TMI3408D. Check the following in your layout:

1. The power traces, consisting of the GND trace, the LX trace and the VIN trace should be kept short, direct and wide.
2. Does the (+) plates of Cin connect to Vin as closely as possible. This capacitor provides the AC current to the internal power MOSFETs.
3. Keep the switching node, LX, away from the sensitive VOUT node.
4. Keep the (-) plates of Cin and Cout as close as possible.

PACKAGE INFORMATION

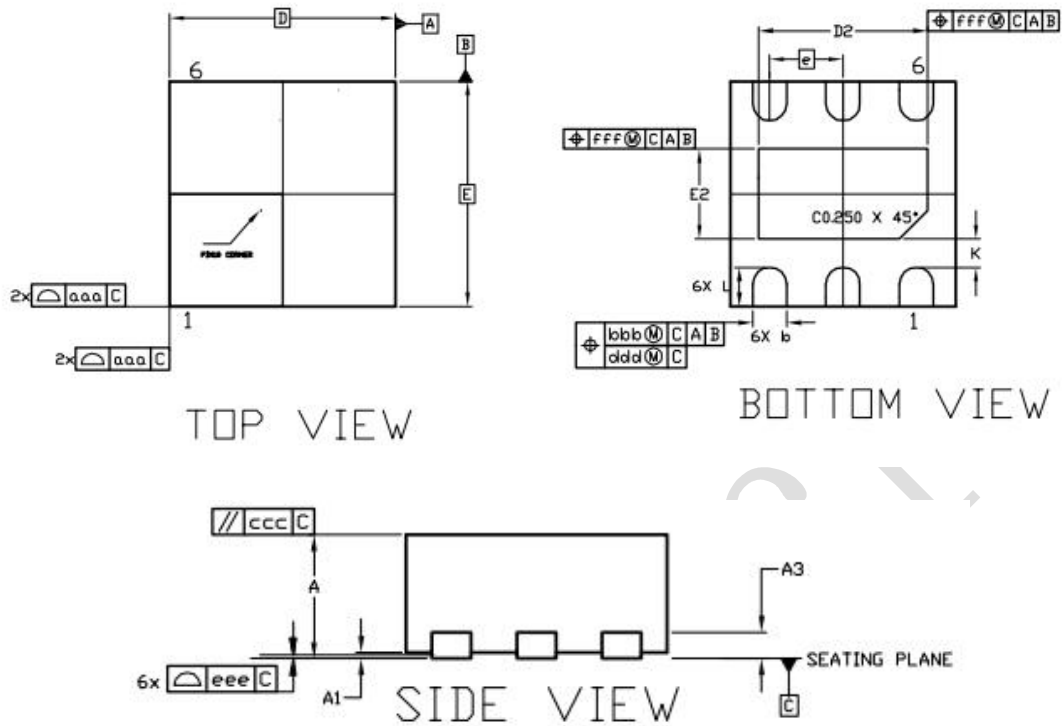

DIM SYMBOL	MIN.	NOM.	MAX.
	0.70	0.75	0.80
A	0.80	0.85	0.90
A1	0	0.02	0.05
A3	-	0.20 REF	-
b	0.25	0.30	0.35
D	2.00BSC		
E	2.00BSC		
D2	1.45	1.50	1.55
E2	0.75	0.80	0.85
e	0.65BSC		
L	0.30	0.35	0.40
K	0.20	-	-
aaa	0.15		
bbb	0.10		
ccc	0.10		
ddd	0.05		
eee	0.08		
fff	0.10		

DFN2*2-6

单击下面可查看定价，库存，交付和生命周期等信息

[>>TMI](#)