

# XCA204A0K1MR

CTR05092-001

## 18V Operation 3.0A Synchronous Step-Down DC/DC Converters

### ■ GENERAL DESCRIPTION

The XCA204A0K1MR is 18V bootstrap synchronous step-down DC/DC converter with built-in Nch-Nch driver FET, the operating voltage range is 4.5V to 18.0V, designed to allow the use of ceramic capacitors.

0.765V reference voltage source is incorporated in the IC, and the output voltage can be set to a value from 0.8V to  $0.65 \times V_{IN}$  or 7.0V (Max) using external resistors (R1, R2).

Switching frequency is 700kHz. In PWM/PFM automatic switchover control, IC can change the control method between PWM and PFM based on the output current requirement and as a result IC can achieve high efficiency over the full load range.

XCA204A0K1MR has a fixed internal soft-start time which is 1.3ms, with the built-in UVLO function, the driver FET is forced OFF when input voltage goes down to 4.1V or lower. Over current protection and thermal shutdown are embedded and they secure a safety operation.

### ■ APPLICATIONS

- Set Top Box
- Portable TV
- LCD TV
- AP Router

### ■ FEATURES

Input Voltage Range	:	4.5V ~ 18V (Absolute Max 20V)
Output Voltage Range	:	0.8V ~ $0.65 \times V_{IN}$ or 7V Max
FB Voltage	:	0.765V $\pm$ 3.0%
Output Current	:	3.0A
Oscillation Frequency	:	700kHz
Control Method	:	PWM/PFM Automatic
Efficiency	:	Up to 92%
Internal Power MOSFET	:	High-side : 85m $\Omega$ Low-side : 45m $\Omega$
Soft-start Time	:	1.3ms
Protection	:	UVLO Current Limit Thermal Shutdown
Low ESR Ceramic Capacitor	:	Ceramic Capacitor
Operating Ambient Temperature	:	-40°C ~ 85°C
Package	:	SOT23-6
Environmentally Friendly	:	EU RoHS Compliant

### ■ TYPICAL APPLICATION CIRCUIT

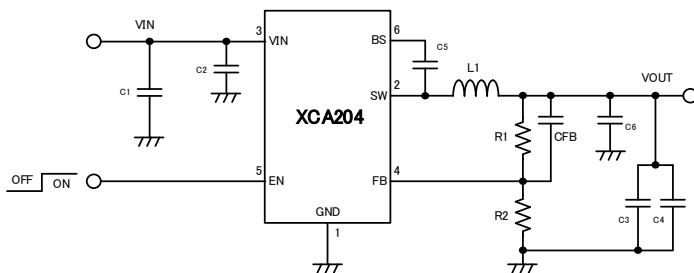

### ■ TYPICAL PERFORMANCE CHARACTERISTICS

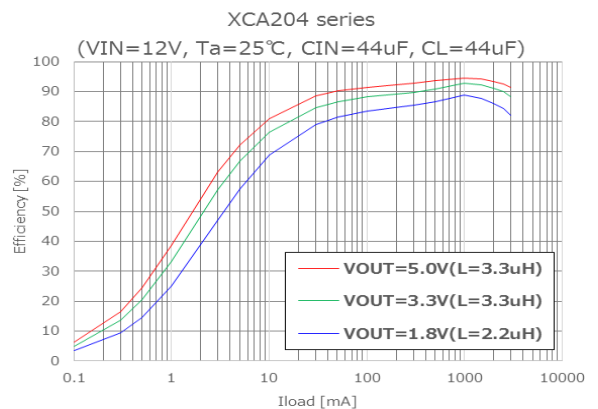

Name	Number	Value	Model number
CIN	2	22uF	TMK212BBJ226MG (TAIYO YUDEN)
CL	2	22uF	LMK212BBJ226MG (TAIYO YUDEN)
L	1	2.2uH	CLF6045NIT-2R2N (TDK)
	1	3.3uH	CLF6045NIT-3R3N (TDK)

## ■ BLOCK DIAGRAM

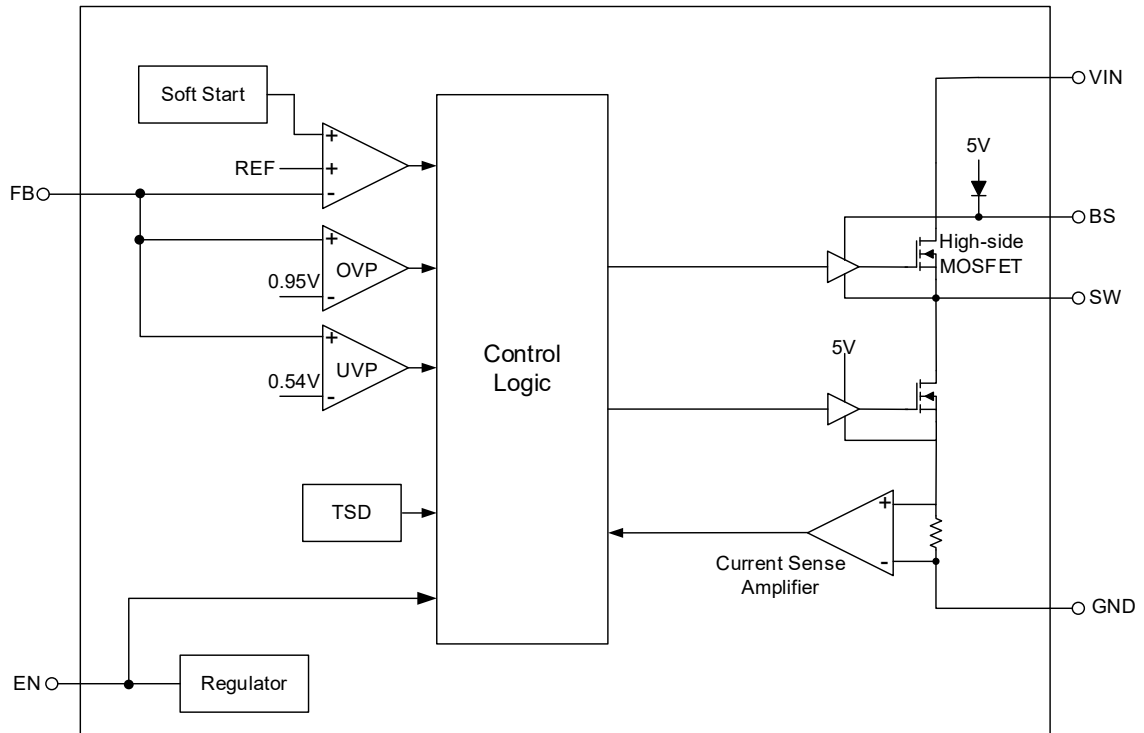

## ■ PRODUCT CLASSIFICATION

### ● Ordering Information

Product Name	Package Name	Order Unit	Shipment
XCA204A0K1MR	SOT23-6	3,000pcs/Reel	Tape & Reel

### ● Selection Guide

Chip Enable	Over Voltage Protection	Thermal Shutdown	Soft Start	UVLO	Current Limit
YES	YES	YES	YES	YES	YES

## ■ PIN CONFIGURATION

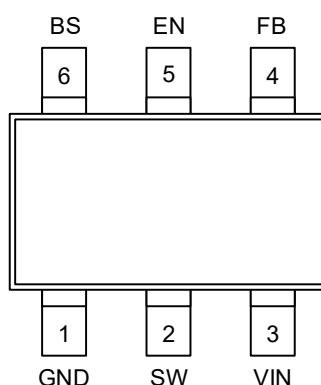

## ■ PIN ASSIGNMENT

PIN NUMBER	PIN NAME	FUNCTION
1	GND	Ground. This pin is the voltage reference for the regulated output voltage. For this reason care must be taken in its layout.
2	SW	Switch Output. Connect this pin to the switching end of the inductor.
3	VIN	Power Supply Input. Drive 4.5V to 18V voltage to this pin to power on this chip. Connecting a 10 $\mu$ F~22 $\mu$ F ceramic bypass capacitor between VIN and GND to eliminate noise.
4	FB	Feedback. An external resistor divider from the output to GND, tapped to the FB pin sets the output voltage.
5	EN	ON/OFF Control Input. Pull EN above 1.8V to turn the device on.
6	BS	Bootstrap. A 100nF capacitor is connected between SW and BS pins to drive the power switch's gate above the supply voltage.

## ■ FUNCTION CHART

PIN NAME	SIGNAL	STATUS
EN	L or OPEN	Stand-by
	H	Active

## ■ ABSOLUTE MAXIMUM RATINGS<sup>(\*)</sup>

Ta=25°C

PARAMETER	SYMBOL	RATINGS	UNITS
Input Supply Voltage Pin	V <sub>IN</sub>	-0.3 ~ 20	V
EN Voltage Pin	V <sub>EN</sub>	-0.3 ~ 20	V
SW Voltage Pin	V <sub>SW</sub>	-0.3 ~ 20	V
Boost Voltage Pin	V <sub>BS</sub>	V <sub>SW</sub> - 0.3 ~ V <sub>SW</sub> + 5.8	V
FB Voltage Pin	V <sub>FB</sub>	-0.3 ~ 5.6	V
Maximum Junction Temperature	T <sub>j</sub>	150	°C
Thermal resistance(Junction-Air)	θ <sub>JA</sub>	88	°C/W
Thermal resistance(Junction-Case)	θ <sub>JC</sub>	45	°C/W
Operating Ambient Temperature	T <sub>opr</sub>	-40 ~ 85	°C
Storage Temperature	T <sub>stg</sub>	-65 ~ 150	°C

(\*) Stresses exceed those ratings may damage the device.

## ■ ELECTRICAL CHARACTERISTICS

Ta=25°C

PARAMETER	SYMBOL	CONDITIONS	MIN.	TYP.	MAX.	UNIT
Input Voltage Range	V <sub>IN</sub>		4.5	-	18.0	V
Supply Current (Quiescent)	I <sub>Q</sub>	V <sub>EN</sub> = V <sub>IN</sub> , No switching	-	300	-	μA
Supply Current (Shutdown)	I <sub>STBY</sub>	V <sub>EN</sub> = 0V	-	3	10	μA
Feedback Voltage	V <sub>FB</sub>		0.742	0.765	0.788	V
Feedback Current	I <sub>FB</sub>	V <sub>FB</sub> = 1V	-0.1	0	0.1	μA
Switch-On High-Side Resistance <sup>(*)</sup>	R <sub>D<sub>SH</sub>(ON)</sub>		-	85	-	mΩ
Switch-On Low-Side Resistance <sup>(*)</sup>	R <sub>D<sub>SL</sub>(ON)</sub>		-	45	-	mΩ
Switch Leakage	I <sub>SW</sub>	V <sub>EN</sub> = 0V, V <sub>SW</sub> = 0V	-	-	10	μA
Current Limit <sup>(*)</sup>	I <sub>OC</sub>	DC current, V <sub>OUT</sub> = 1.8V	3.1	4.0	-	A
Oscillator Frequency	f <sub>SW</sub>	V <sub>OUT</sub> = 5V@1A Load	560	700	880	kHz
Soft-start time <sup>(*)</sup>	t <sub>SS</sub>	V <sub>FB</sub> = 0V to 0.7V	-	1.3	-	ms
Minimum ON-Time <sup>(*)</sup>	t <sub>ON</sub>		-	150	-	ns
Minimum OFF-Time <sup>(*)</sup>	t <sub>OFF</sub>		-	250	360	ns
Under Voltage Lockout Threshold	V <sub>UVLOR</sub>	V <sub>IN</sub> Rising, V <sub>OUT</sub> = 1V	-	4.1	4.4	V
Under Voltage Lockout Threshold Hysteresis	V <sub>UVLOH</sub>	V <sub>OUT</sub> = 1V	-	250	-	mV
EN pin resistance to GND	R <sub>EN</sub>		0.7	1.2	1.8	MΩ
EN Up Threshold Voltage	V <sub>ENH</sub>		1.8	-	18.0	V
EN Down Threshold Voltage	V <sub>ENL</sub>		GND	-	0.4	V
Thermal Shutdown <sup>(*)</sup>	T <sub>TSD</sub>		-	150	-	°C

Test Condition: Unless otherwise stated, V<sub>IN</sub>=9V, V<sub>EN</sub>=2V

<sup>(\*)</sup> Design reference value.

## TYPICAL APPLICATION CIRCUIT

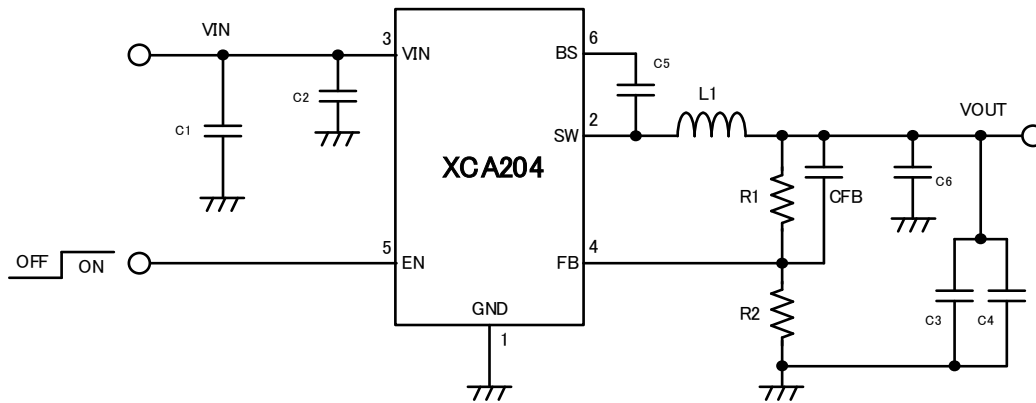

Figure.1 Typical Application Circuit

【Table1 : Recommended Component Selection】

V <sub>OUT</sub>	R1	R2	CFB	L1	C1	C2	C3+C4 <sup>(*)</sup>	C5	C6
7.0V	81.5kΩ	10kΩ	Optional	4.7μH	22μF/25V Ceramic	0.1μF/25V Ceramic	68μF Ceramic	0.1μF Ceramic	0.1μF Ceramic
5.0V	54.9kΩ	10kΩ	Optional	3.3μH	22μF/25V Ceramic	0.1μF/25V Ceramic	44~68μF Ceramic	0.1μF Ceramic	0.1μF Ceramic
3.3V	33.2kΩ	10kΩ	Optional	3.3μH	22μF/25V Ceramic	0.1μF/25V Ceramic	44~68μF Ceramic	0.1μF Ceramic	0.1μF Ceramic
1.8V	13.6kΩ	10kΩ	Optional	2.2μH	22μF/25V Ceramic	0.1μF/25V Ceramic	44~68μF Ceramic	0.1μF Ceramic	0.1μF Ceramic
1.0V	3.09kΩ	10kΩ	Optional	1.5μH	22μF/25V Ceramic	0.1μF/25V Ceramic	44~68μF Ceramic	0.1μF Ceramic	0.1μF Ceramic

<sup>(\*)</sup> V<sub>OUT</sub>=0.8V ~ 5.0V : (C3+C4) = 44μF to 68μF (Ceramic)  
 V<sub>OUT</sub>=5.1V ~ 7.0V : (C3+C4) = 68μF (Ceramic)

【Table2 : Parts example for evaluation】

Name	Number	Value	Parts number	Vender
L1	(*)	1.5μH	CLF6045NIT-1R5N	TDK
		2.2μH	CLF6045NIT-2R2N	TDK
		3.3μH	CLF6045NIT-3R3N	TDK
		4.7μH	CLF6045NIT-4R7N	TDK
C1	1	22μF	TMK212BBJ226MG	TAIYO YUDEN
C2	1	0.1μF	TMK105BJ104KP	TAIYO YUDEN
C3, C4	(**)	22μF	LMK212BBJ226MG	TAIYO YUDEN
		68μF	C3216X5R1A686M160AC	TDK
C5	1	0.1μF	UMK105B7104KV	TAIYO YUDEN
C6	1	0.1μF	UMK105B7104KV	TAIYO YUDEN

<sup>(\*)</sup> Select according to V<sub>OUT</sub> setting voltage.

<sup>(\*\*)</sup> C3+C4=44μF : Two 22μF used in parallel

## ■ Function Description

The main control loop of XCA204A0K1MR are adaptive on-time pulse width modulation (PWM) controller. The control mechanism combines adaptive on-time control with an internal compensation circuit for pseudo-fixed frequency and low external component count configuration with both low ESR and ceramic output capacitors. It is stable even with virtually no ripple at the output.

At the beginning of each cycle, the high-side MOSFET is turned on. This MOSFET is turned off after internal one shot timer expires. This one shot duration is set proportional to the converter input voltage,  $V_{IN}$ , and inversely proportional to the output voltage,  $V_{OUT}$ , to maintain a pseudo-fixed frequency over the input voltage range, hence it is called adaptive on-time control. The one-shot timer is reset and the high-side MOSFET is turned on again when the feedback voltage falls below the reference voltage.

### < Enable >

The XCA204A0K1MR EN pin provides digital control to turn on/turn off the regulator. When the voltage of EN exceeds the threshold voltage, the regulator starts the soft start function. If the EN pin voltage is below than the shutdown threshold voltage, the regulator will be disable and into the shutdown mode.

### < Output Over Voltage Protection >

When the FB pin voltage exceeds 25% of the regulation voltage, the output over voltage protection function will turn the high side MOSFET off.

### < Input Under Voltage Lockout (UVLO) >

When the XCA204A0K1MR power on, the internal circuits are held inactive until  $V_{IN}$  exceeds the input UVLO threshold voltage. And the regulator will be disabled when  $V_{IN}$  below the input UVLO threshold voltage. The hysteretic of the UVLO comparator is 250mV.

### < Short Protection >

The XCA204A0K1MR provides short protection function to prevent the device damage from short condition. When the output short to ground, the oscillator frequency is reduced to prevent the inductor current increasing beyond the current limit. In the meantime, the current limit is also reduced to lower the short current. Once the short condition is removed, the frequency and current limit will return to normal.

### < Thermal Shutdown >

The XCA204A0K1MR incorporates an over temperature protection circuit to protect itself from overheating. When the junction temperature exceeds the thermal shutdown threshold temperature, the regulator will be shutdown.

## Application Information

### < Output Voltage Setting >

The external resistor divider is used to set the output voltage. XCA204A0K1MR feedback resistors are unconcerned of compensation and provide an easy way to program output voltage. Table 1 shows a list of resistor selection for common output voltages:

$$V_{OUT} = 0.765V \times (1 + R1/R2)$$

### < Selecting the Inductor >

A 4.7μH inductor with a DC current rating of at least 30% percent higher than the maximum load current is recommended for most applications. For highest efficiency, the inductor's DC resistance should be less than 50mΩ. For most designs, the required inductance value can be derived from the following equation:

$$\Delta I = 0.3 \times I_{L(MAX)}$$

$$L \geq \frac{V_{OUT}}{f_{SW} \cdot \Delta I} \cdot \left(1 - \frac{V_{OUT}}{V_{IN}}\right)$$

Where ΔI is the inductor ripple current.

Choose the inductor ripple current to be 30% of the maximum load current. The maximum inductor peak current is calculated from:

$$I_{L(MAX)} = I_{LOAD(MAX)} + \frac{\Delta I}{2}$$

But when a coil with poor DC superimposition(DC bias) characteristics is used, the inductor peak current may increase due to the derating of the inductor during soft start. In this case, please use a coil with better DC superimposition (DC bias) characteristics.

Under light load conditions below 100mA, a larger inductance is recommended for improved efficiency.

### < Selecting the Input Capacitor >

The input capacitor reduces the surge current drawn from the input supply and the switching noise from the device. The input capacitor impedance at the switching frequency should be less than the input source impedance to prevent high frequency switching current from passing through the input. Ceramic capacitors with X5R or X7R dielectrics are highly recommended because of their low ESR and small temperature coefficients. For most applications, a 22μF capacitor is sufficient.

### < Selecting the Output Capacitor >

The output capacitor keeps the output voltage ripple small and one or two 22μF ceramic capacitor with X5R or X7R dielectrics is recommended for its low ESR characteristics.

### < External Boost Diode Selection >

An external bootstrap diode is recommended if the input voltage is less than 5.5V, or duty cycle is high, or if there is a 5V system rail available. This diode helps improve the efficiency. Low cost diodes, such as B0520 are suitable for this application.

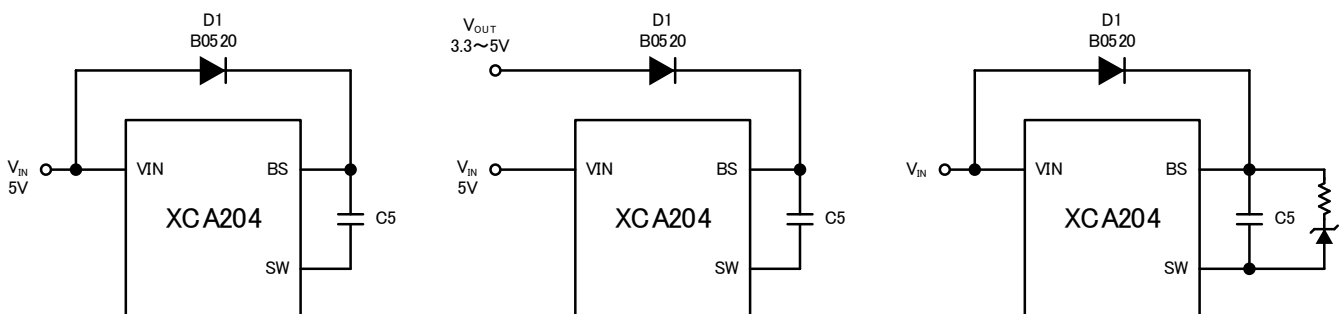



## ■ Note on use

1. When the VIN voltage is lower than UVLO and the temperature is low, there is a possibility of step-down operation.
2. When the input voltage is low, the maximum load current may decrease.
3. Be especially careful of the capacitor characteristics and use X7R or X5R (EIA standard) ceramic capacitors. The capacitance decrease caused by the bias voltage may become remarkable depending on the external size of the capacitor.
4. Even within the operating temperature range, the thermal shutdown function may operate depending on the input voltage, output voltage and output current. An example of derating characteristics is shown below. Please evaluate IC well on your PCB.

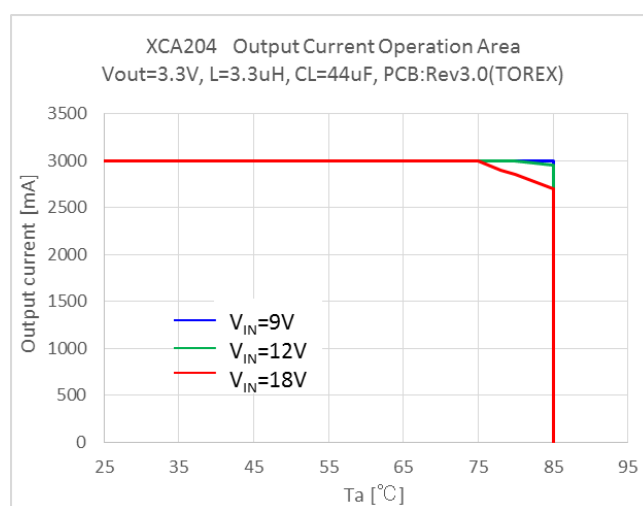

## < PCB Layout Recommendation >

The device's performance and stability is dramatically affected by PCB layout. It is recommended to follow these general guidelines show bellow:

1. Place the input capacitors, output capacitors as close to the device as possible. Trace to these capacitors should be as short and wide as possible to minimize parasitic inductance and resistance.
2. CIN must be closes to Pins VIN and GND. The loop area formed by CIN and VIN/GND pins must be minimized.
3. The GND trace between the output capacitor and the GND pin should be as wide as possible to minimize its race impedance.
4. Do not allow switching current to flow under the device.
5. Place feedback resistors close to the FB pin. A separate  $V_{OUT}$  path should be connected to the upper feedback resistor
6. Keep the sensitive signal (FB) away from the switching signal (SW). The trace of the FB node should be as small as possible to avoid noise coupling.
7. Multi-layer PCB design is recommended.

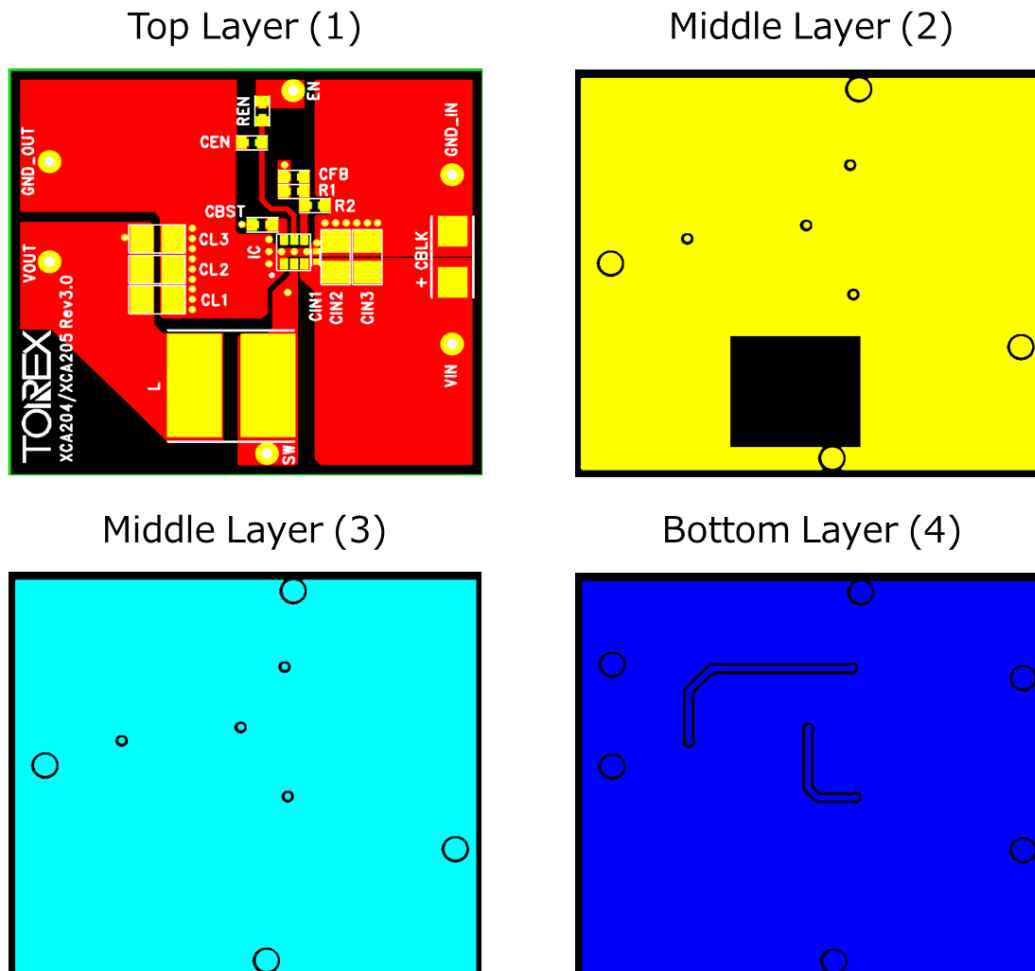

Dimensions : 40mm×45mm (4 layer)  
Copper thickness : 1oz  
Material : Glass Epoxy (FR-4)  
Thickness : 1.6mm

# TYPICAL PERFORMANCE CHARACTERISTICS

C1=22μF, C2=0.1μF, C3=C4=22μF, C5=C6=0.1μF, Ta = 25°C, unless otherwise noted.

## Efficiency Test

Vin=12V

### Efficiency vs Output Current

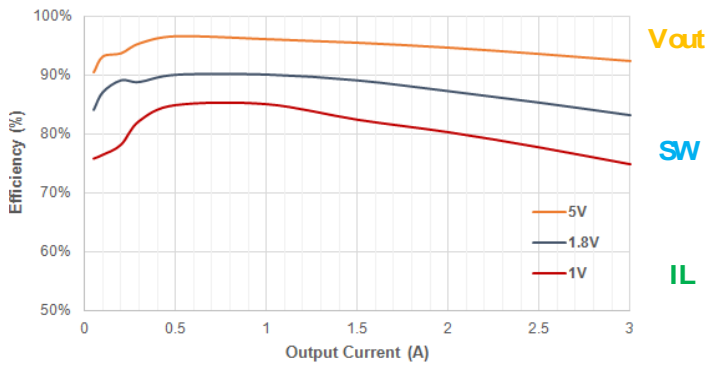

## Steady State

Vin=12V, Vout=1.8V, Iout=0A

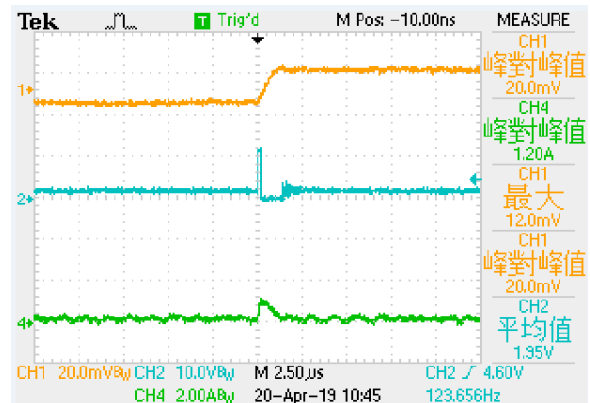

## Steady State

Vin=12V, Vout=1.8V, Iout=2.0A

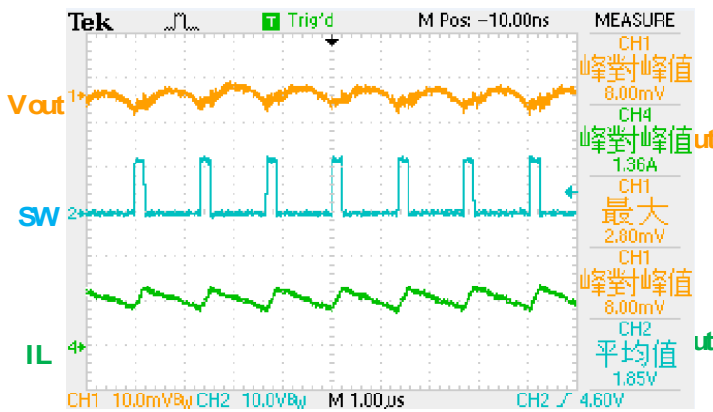

## Dynamic loading

Vin=12V, Vout=1.8V, Iout=0.3 to 2.7A, 0.5A/us

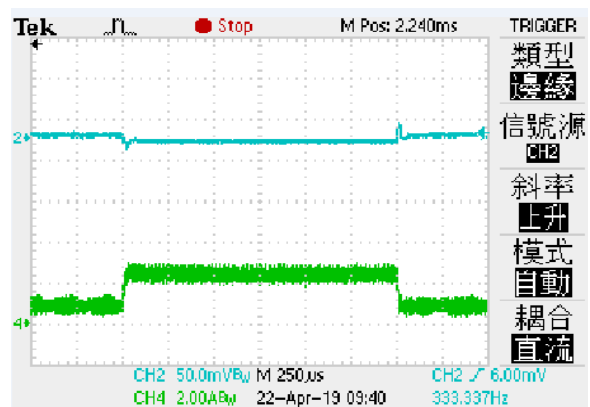

## Power On

Vin=12V, Vout=1.8V, Iout=2.0A

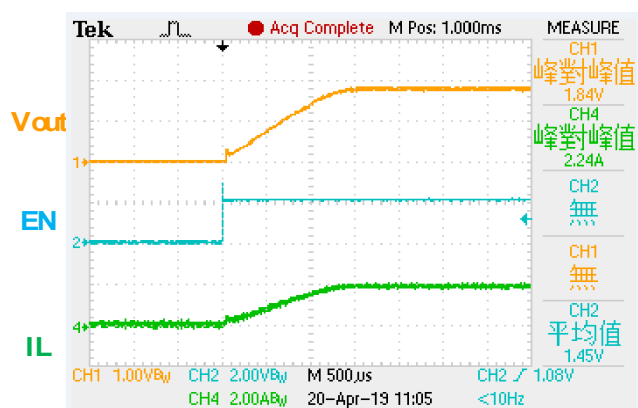

## Shut Down

Vin=12V, Vout=1.8V, Iout=2A

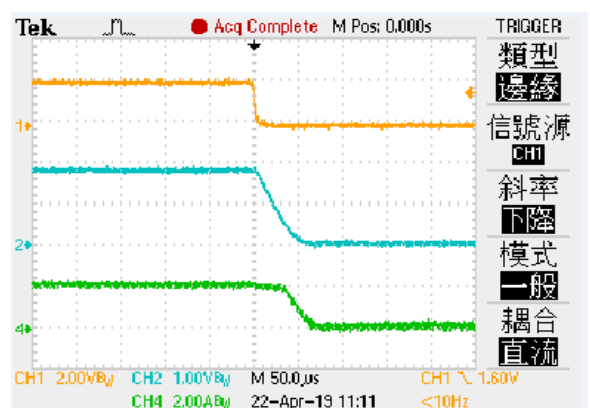

## PACKAGING INFORMATION

●SOT23-6 (unit:mm)

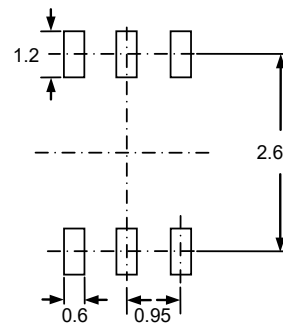
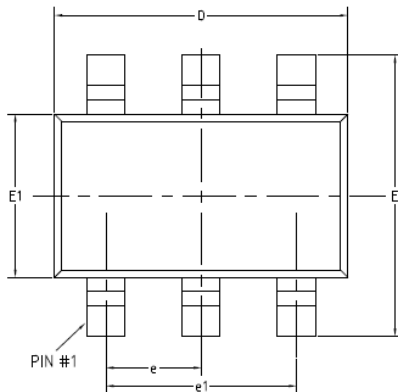

(PCB FOOTPRINT)

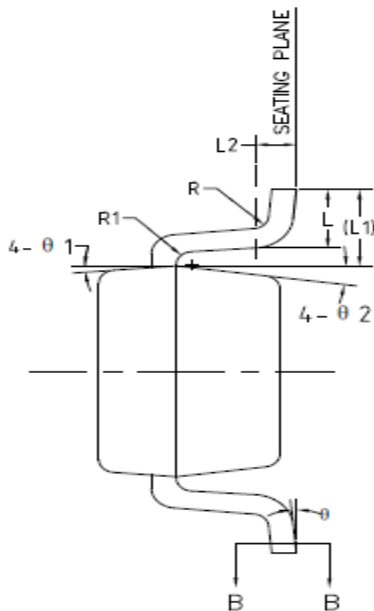
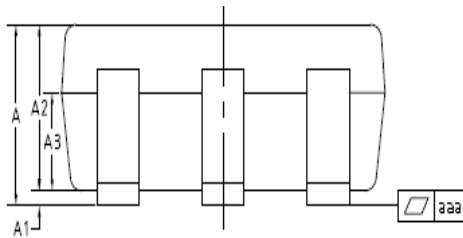

Unit:mm

SYMBOLS	Min	Typ	Max
A	-	-	1.45
A1	0	-	0.15
A2	0.90	1.10	1.30
b	0.39	-	0.49
b1	0.38	0.4	0.45
c	0.12	-	0.19
c1	0.11	0.13	0.15
D	2.85	2.95	3.05
E	2.60	2.80	3.00
E1	1.55	1.65	1.75
e	0.85	0.95	1.05
e1	1.80	1.90	2.00
L	0.35	0.45	0.55
L1	0.59 REF		
L2	0.25 BSC		
R	0.05	-	-
R1	0.05	-	0.2
$\Theta$	0°	-	8°
$\Theta 1$	8°	10°	12°
$\Theta 2$	8°	10°	12°
aaa	0.1		

### NOTES:

1. JEDEC OUTLINE: N/A
2. DIMENSIONS "D" DOES NOT INCLUDE MOLD FLASH, PROTRUSIONS OR GATE BURRS. MOLD FLASH, PROTRUSIONS AND GATE BURRS SHALL NOT EXCEED .15mm (.006in) PER SIDE.
3. DIMENSIONS "E" DOES NOT INCLUDE INTER-LEAD FLASH, OR PROTRUSIONS. INTER-LEAD FLASH AND PROTRUSIONS SHALL NOT EXCEED .25mm (.010in) PER SIDE.

■ MARKING RULE

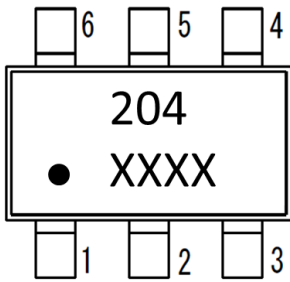

204: Part No. XCA204A0K1MR  
XXXX: Denotes assembly Data Code & Lot No.

1. The product and product specifications contained herein are subject to change without notice to improve performance characteristics. Consult us, or our representatives before use, to confirm that the information in this datasheet is up to date.
2. The information in this datasheet is intended to illustrate the operation and characteristics of our products. We neither make warranties or representations with respect to the accuracy or completeness of the information contained in this datasheet nor grant any license to any intellectual property rights of ours or any third party concerning with the information in this datasheet.
3. Applicable export control laws and regulations should be complied and the procedures required by such laws and regulations should also be followed, when the product or any information contained in this datasheet is exported.
4. The product is neither intended nor warranted for use in equipment of systems which require extremely high levels of quality and/or reliability and/or a malfunction or failure which may cause loss of human life, bodily injury, serious property damage including but not limited to devices or equipment used in 1) nuclear facilities, 2) aerospace industry, 3) medical facilities, 4) automobile industry and other transportation industry and 5) safety devices and safety equipment to control combustions and explosions. Do not use the product for the above use unless agreed by us in writing in advance.
5. Although we make continuous efforts to improve the quality and reliability of our products nevertheless Semiconductors are likely to fail with a certain probability. So in order to prevent personal injury and/or property damage resulting from such failure, customers are required to incorporate adequate safety measures in their designs, such as system fail safes, redundancy and fire prevention features.
6. Our products are not designed to be Radiation-resistant.
7. Please use the product listed in this datasheet within the specified ranges.
8. We assume no responsibility for damage or loss due to abnormal use.
9. All rights reserved. No part of this datasheet may be copied or reproduced unless agreed by Torex Semiconductor Ltd in writing in advance.
10. This is a special product which is allowed to be promoted to Customers outside Japan only. The delivery is not going through Torex HQ in Japan but going through Torex Taiwan office.

TOREX SEMICONDUCTOR LTD.

单击下面可查看定价，库存，交付和生命周期等信息

[>>Torex Semiconductor\(特瑞仕\)](#)