

COT Control, 3.0A Synchronous Step-Down DC/DC Converters

☆Green Operation-compatible

■ GENERAL DESCRIPTION

The XC9273 series is a group of synchronous-rectification type DC/DC converters with a built-in 47mΩ P-channel MOS driver transistor and 36mΩ N-channel MOS switching transistor, designed to allow the use of ceramic capacitors. The small on-resistances of these two internal driver transistors enable a high efficiency, stable power supply with an output current up to 3.0A. A 0.6V reference voltage source is incorporated, and the output voltage can be set freely by external resistors. Oscillation frequency is set to 1.2MHz or 3.0MHz can be selected for suiting to your particular application. The operation mode is HISAT-COT (*) control, which has an excellent transient response. PWM control or PWM/PFM auto switching control can be selected at the MODE1 pin, and a high-speed response, low ripple, and high efficiency are achieved across the entire load range (from light loads to heavy loads). During stand-by, all circuits are shutdown to reduce current consumption to as low as 1.0μA or less. As for the soft-start function as fast as 0.25ms in typical for quick turn-on. The soft start time can be set as desired by adding an external capacitance to the SS pin. Internal protection circuits include over current protection, short-circuit protection, and thermal shutdown circuits to enable safe use. Short circuit protection or Hiccup mode can be selected at the MODE2 pin.

Soft-off function and C_L High Speed discharge function discharge the electric charge at the output capacitor C_L when putting the IC in a stand-by mode. Soft-off function can be selected at the MODE3 pin. The package is the QFN0404-24C (4mm × 4mm).

(*) HISAT-COT is an original Torex term for High Speed Transient Response.

■ APPLICATIONS

- PC
- Graphic board
- Storage
- Industrial application
- FPGA
- SSD
- ASIC
- DSP

■ FEATURES

| | |
|-------------------------------|---|
| Input Voltage Range | : 2.7V~5.5V |
| Output Voltage Range | : 0.8V~3.6V |
| FB Voltage | : 0.6V±1.0% |
| Output Current | : 3.0A |
| Oscillation Frequency | : 1.2MHz, 3.0MHz |
| Efficiency | : 95%($V_{IN}=5.0V$, $V_{OUT}=3.3V$, $I_{OUT}=1.0A$) |
| Control Methods | : HiSAT-COT Control 100% Duty Cycle Mode select between Fixed PWM and PWM/PFM Auto |
| Protection Circuits | : Thermal Shutdown Current Limit (Pendent character) HICCUP or Short Circuit Protection |
| Functions | : UVLO , Soft-Start, Soft-off C_L High Speed Discharge |
| Capacitor | : Ceramic Capacitor |
| Operating Ambient Temperature | : -40°C ~ +105°C |
| Package | : QFN0404-24C |
| Environmentally Friendly | : EU RoHS Compliant, Pb Free |

■ TYPICAL APPLICATION CIRCUIT

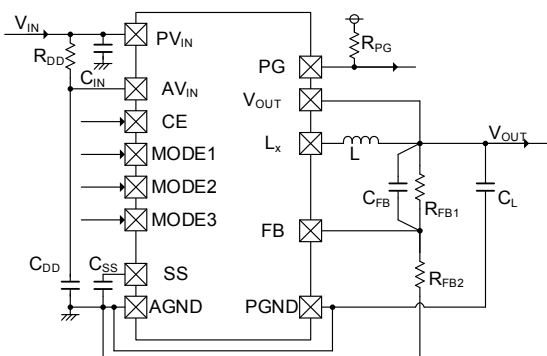

■ TYPICAL PERFORMANCE CHARACTERISTICS

XC9273B06C $V_{OUT}=1.8V$, $f_{osc}=1.2MHz$ $L=0.56\mu H$ (MWSA0603),
 $C_{IN}=47\mu F$ (GRM31CR61A476ME15L), $C_L=47\mu F$ (GRM31CR60J476ME19L), $R_{FB1}=36k\Omega$, $R_{FB2}=18k\Omega$, $C_{FB}=1500pF$

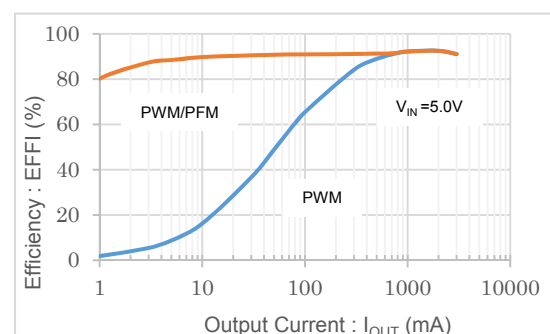

XC9273 Series

■ BLOCK DIAGRAM

●XC9273

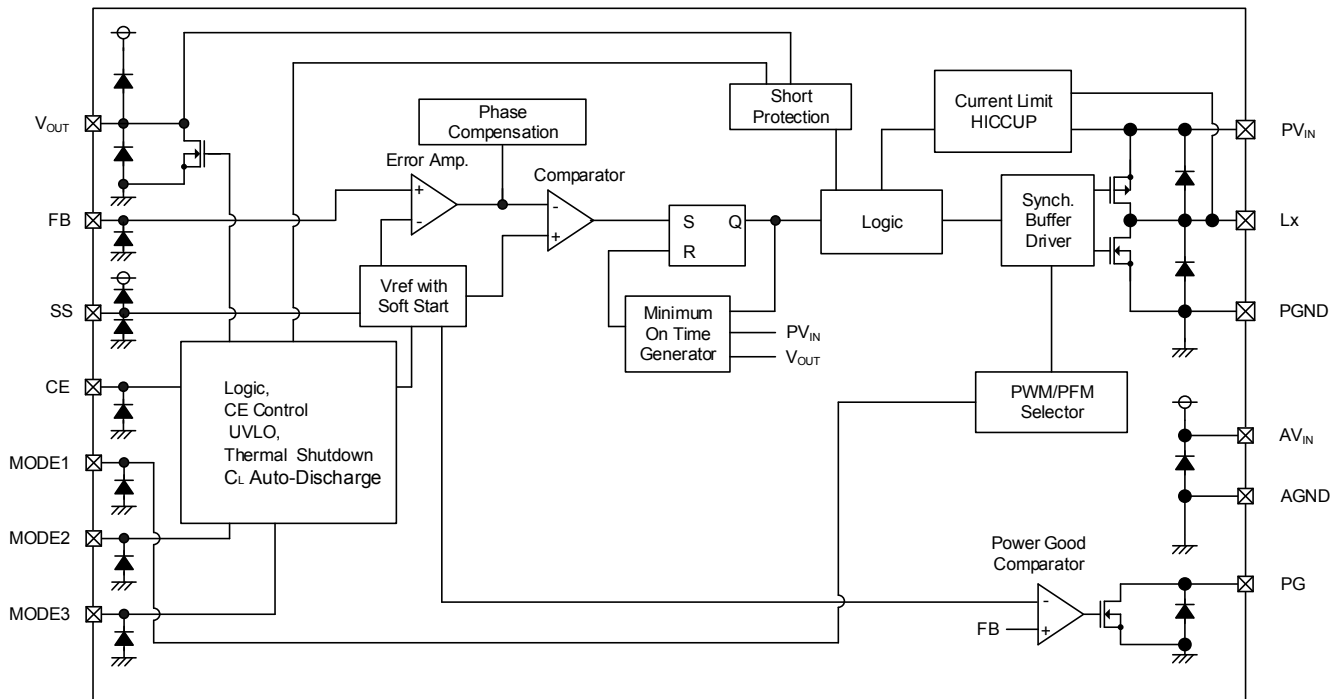

* Diodes inside the circuit are an ESD protection diode and a parasitic diode.

■ PRODUCT CLASSIFICATION

1) Ordering Information

XC9273①②③④⑤⑥-⑦ PWM Control ⇔ PWM/PFM Automatic switching control

| DESIGNATOR | ITEM | SYMBOL | DESCRIPTION |
|------------|---------------------------|--------|--|
| ① | Type | B | Refer to Selection Guide |
| ②③ | Adjustable Output Voltage | 06 | Output voltage can be adjusted in 0.8V to 3.6V |
| ④ | Oscillation Frequency | C | 1.2MHz |
| | | D | 3.0MHz |
| ⑤⑥-⑦ (*) | Package (Order Unit) | ZR-G | QFN0404-24C (1,000pcs/Reel) |

(*) The "-G" suffix denotes Halogen and Antimony free as well as being fully RoHS compliant.

2) Selection Guide

| TYPE | C. AUTO-DISCHARGE with SOFT-OFF | SHORT PROTECTION with LATCH or HICCUP MODE | UVLO | CHIP ENABLE |
|------|------------------------------------|---|------|-------------|
| B | Yes | Yes | Yes | Yes |

| TYPE | CURRENT LIMIT | SOFT-START TIME | THERMAL SHUTDOWN | POWER GOOD |
|------|---------------|-----------------|------------------|------------|
| B | Yes | Adjustable | Yes | Yes |

XC9273 Series

PIN CONFIGURATION

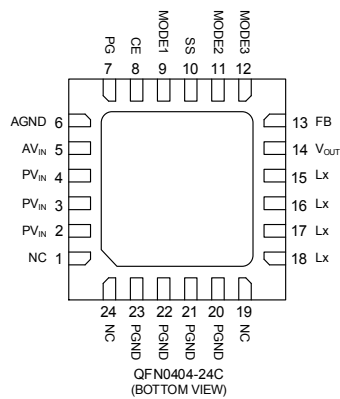

* The dissipation pad for the QFN0404-24C package should be solder-plated in recommended mount pattern and metal masking so as to enhance mounting strength and heat release. If the pad needs to be connected to other pins, it should be connected to the GND (No. 6,20,21,22,23) pin.

PIN ASSIGNMENT

| PIN NUMBER | PIN NAME | FUNCTIONS |
|-------------|------------------|-----------------------------|
| 1, | NC | No Connection |
| 2,3,4 | PV _{IN} | Power Supply Voltage Input |
| 5 | AV _{IN} | Analog Supply Voltage Input |
| 6 | AGND | Analog Ground |
| 7 | PG | Power-good Output |
| 8 | CE | Chip Enable |
| 9 | MODE1 | Control Mode Select |
| 10 | SS | Soft start |
| 11 | MODE2 | Protection Function Select |
| 12 | MOED3 | SOFT-OFF Select |
| 13 | FB | Output Voltage Sense |
| 14 | V _{OUT} | Output Voltage Sense |
| 15,16,17,18 | Lx | Switching Output |
| 19 | NC | No Connection |
| 20,21,22,23 | PGND | Power Ground |
| 24 | NC | No Connection |

FUNCTION

| PIN NAME | SIGNAL | STATUS |
|----------|--------|----------|
| CE | L | Stand-by |
| | H | Active |

Please do not leave the CE pin open.

| PIN NAME | SIGNAL | STATUS |
|----------|--------|---|
| MODE1 | L | PWM/PFM automatic control |
| | H | PWM control |
| MODE2 | L | SHORT PROTECTION with LATCH |
| | H | HICCUP MODE |
| MODE3 | L | C _L AUTO-DISCHARGE |
| | H | C _L AUTO-DISCHARGE with SOFT-OFF |

Please do not leave the MODE1, MODE2, MODE3 pin open

■ ABSOLUTE MAXIMUM RATINGS

Ta=25°C

| PARAMETER | | SYMBOL | RATINGS | UNITS |
|-------------------------------|-------------|------------------------|---|-------|
| Power Input Voltage | | V _{PVIN} | -0.3~+6.2 | V |
| Analog Input Voltage | | V _{AVIN} | | |
| Lx PIN Voltage | | V _{Lx} | -0.3~V _{IN} +0.3 or+6.2 ^{(*)1} | V |
| Output Voltage | | V _{OUT} | -0.3~V _{IN} +0.3 or+4.0 ^{(*)2} | V |
| Feedback Input Voltage | | V _{FB} | -0.3~+6.2 | V |
| CE Input Voltage | | V _{CE} | -0.3~+6.2 | V |
| MODE1 Input Voltage | | V _{MODE1} | -0.3~+6.2 | V |
| MODE2 Input Voltage | | V _{MODE2} | -0.3~+6.2 | V |
| MODE3 Input Voltage | | V _{MODE3} | -0.3~+6.2 | V |
| PG Input Voltage | | V _{PG} | -0.3~+6.2 | V |
| Soft Start Input Voltage | | V _{SoftStart} | -0.3~V _{IN} +0.3 or +6.2 ^{(*)1} | V |
| Power Dissipation | QFN0404-24C | P _d | 1500 (PCB mounted) | mW |
| Operating Ambient Temperature | | T _{opr} | -40~+105 | °C |
| Storage Temperature | | T _{stg} | -55~+125 | °C |

All voltages are described based on the GND (AGND and PGND) pin.

(*)1 The maximum value should be either V_{IN}+0.3V or +6.2V in the lowest.

(*)2 The maximum value should be either V_{IN}+0.3V or +4.0V in the lowest.

XC9273 Series

ELECTRICAL CHARACTERISTICS

XC9273 Series

Ta=25°C

| PARAMETER | SYMBOL | CONDITIONS | MIN. | TYP. | MAX. | UNITS | CIRCUIT | |
|--|---|--|----------------------------------|-------|-------|--------|---------|---|
| Feedback Voltage | V _{FB} | V _{IN} =5.0V, V _{CE} =V _{MODE1} =V _{MODE2} =V _{IN} , V _{MODE3} =0.0V, Voltage to start oscillation while V _{FB} =0.66V→0.54V | Ta=25°C | 0.594 | 0.600 | 0.606 | V | ④ |
| | | | Ta=0°C~ 85°C ⁽⁹⁾ | 0.594 | 0.600 | 0.606 | V | |
| | | | Ta=40°C~ 105°C ⁽⁹⁾ | 0.591 | 0.600 | 0.609 | V | |
| Load Regulation | ΔV _{LOADREG} | V _{IN} =5.0V ⁽¹⁾ , V _{CE} =V _{MODE1} =V _{MODE2} =V _{IN} , V _{MODE3} =0.0V, I _{OUT} =0mA~3.0A | - | 0.13 | - | % | ① | |
| Operating Voltage Range | V _{IN} | | 2.7 | - | 5.5 | V | ① | |
| Maximum Output Current | I _{OUTMAX} | V _{IN} =2.7V~5.5V ⁽¹⁾ | 3.0 | - | - | A | ① | |
| UVLO Voltage ⁽²⁾ | V _{UVLO} | V _{CE} =V _{IN} , V _{OUT} =0.4V, V _{FB} =0.54V, V _{MODE1} =V _{MODE2} =V _{IN} , V _{MODE3} =0.0V Voltage which Lx pin holding "L" level ⁽⁵⁾ | 2.20 | - | 2.68 | V | ④ | |
| Quiescent Current | I _q | V _{IN} =5.0V, V _{CE} =V _{IN} , V _{OUT} =V _{FB} =0.66V V _{MODE1} =0.0V, V _{MODE2} =V _{IN} , V _{MODE3} =0.0V | - | 40 | 80 | μA | ② | |
| Stand-by Current | I _{STB} | V _{IN} =5.0V, V _{CE} =V _{OUT} =V _{FB} =0.0V V _{MODE1} =V _{MODE2} =V _{MODE3} =0.0V | - | 0.0 | 10.0 | μA | ② | |
| Minimum ON time | t _{ONmin} | When connected to external components, V _{IN} =3.0V, V _{OUT} =1.8V I _{OUT} =1mA V _{CE} =V _{MODE1} =V _{MODE2} =V _{IN} , V _{MODE3} =0.0V | 1.2MHz | 350 | 500 | 650 | ns | ① |
| | | | 3.0MHz | 140 | 200 | 260 | ns | |
| Thermal shutdown | T _{TSD} | - | - | 150 | - | °C | ① | |
| Thermal shutdown hysteresis | T _{HYS} | - | - | 20 | - | °C | ① | |
| Efficiency ⁽³⁾ | EFFI | V _{IN} =5.0V, V _{CE} =V _{MODE1} =V _{MODE2} =V _{IN} , V _{MODE3} =0.0V, V _{OUT} =3.3V, I _{OUT} =1.0A | 1.2MHz, | - | 95 | - | % | ① |
| | | | 3.0MHz, | - | 92 | - | | |
| Lx SW "H" ON Resistance | R _{LXH} | V _{IN} =5.0V, V _{CE} =V _{IN} , V _{OUT} =V _{FB} =0.54V V _{MODE1} =0.0V, V _{MODE2} =V _{IN} , V _{MODE3} =0.0V I _{Lx} =100mA ⁽⁴⁾ | - | 47 | 85 | mΩ | ③ | |
| Lx SW "L" ON Resistance | R _{LXL} | V _{IN} =5.0V, V _{CE} =V _{IN} , V _{OUT} =V _{FB} =0.66V V _{MODE1} =0.0V, V _{MODE2} =V _{IN} , V _{MODE3} =0.0V I _{Lx} =100mA ⁽⁴⁾ | - | 36 | 71 | mΩ | ③ | |
| Lx SW "H" Leakage Current ⁽⁶⁾ | I _{LeakH} | V _{IN} = 5.5V, V _{FB} =0.66V, V _{OUT} =V _{CE} =0.0V, V _{Lx} =5.5V V _{MODE1} =0.0V, V _{MODE2} =V _{IN} , V _{MODE3} =0.0V | - | 0.0 | 50.0 | μA | ⑤ | |
| Lx SW "L" Leakage Current ⁽⁷⁾ | I _{LeakL} | V _{IN} = 5.5V, V _{FB} =0.66V, V _{OUT} =V _{CE} =0.0V, V _{Lx} =0.0V V _{MODE1} =0.0V, V _{MODE2} =V _{IN} , V _{MODE3} =0.0V | - | 0.0 | 10.0 | μA | ⑤ | |
| Current Limit ⁽⁸⁾ | I _{LIM} | V _{IN} =5.0V, V _{CE} =V _{IN} , V _{OUT} =V _{FB} =0.54V V _{MODE1} =0.0V, V _{MODE2} =V _{IN} , V _{MODE3} =0.0V I _{Lx} until Lx pin oscillates | 5.0 | 7.5 | 11.4 | A | ⑥ | |
| Output Voltage Temperature Characteristics | ΔV _{OUT} / (V _{OUT} ·ΔT _{opr}) | I _{OUT} =30mA, -40°C ≤ T _{opr} ≤ 105°C | - | ±30 | - | ppm/°C | ① | |
| PG detect voltage | V _{PG} | V _{IN} =5.0V, V _{CE} =V _{IN} , V _{OUT} =0.54V, V _{MODE1} =0.0V, V _{MODE2} =V _{IN} , V _{MODE3} =0.0V, PG=Pull up 10kΩ(V _{IN}) V _{FB} =0.58V→0.42V, Voltage which PG pin holding "L" level ⁽⁵⁾ | 0.42 | 0.50 | 0.58 | V | ④ | |
| PG Output Current | I _{PG} | V _{IN} =5.0V, V _{CE} =V _{IN} , V _{OUT} =0.54V V _{MODE1} =0.0V, V _{MODE2} =V _{IN} , V _{MODE3} =0.0V V _{FB} =0.42V, PG = 0.5V | 3.6 | 4.5 | 5.5 | mA | ④ | |
| Soft-Start Time1 | t _{SS1} | V _{IN} =5.0V, V _{OUT} =V _{FB} =0.54V, V _{MODE1} =0.0V, V _{MODE2} =V _{IN} , V _{MODE3} =0.0V, V _{CE} =0.0V→3.6V, Time from V _{CE} =3.6V to clocks are generated at Lx pin. C _{SS} = open | 0.10 | 0.25 | 0.50 | ms | ⑦ | |
| Soft-Start Time2 | t _{SS2} | V _{IN} =5.0V, V _{OUT} =V _{FB} =0.54V, V _{MODE1} =0.0V, V _{MODE2} =V _{IN} , V _{MODE3} =0.0V, V _{CE} =0.0V→3.6V, Time from V _{CE} =3.6V to clocks are generated at Lx pin. C _{SS} =3300pF | 1.0 | 2.5 | 5.0 | ms | ⑦ | |

ELECTRICAL CHARACTERISTICS (Continued)

●XC9273 Series

Ta=25°C

| PARAMETER | SYMBOL | CONDITIONS | MIN. | TYP. | MAX. | UNITS | CIRCUIT |
|---------------------------------------|---------------------|--|------|------|------|-------|---------|
| Soft-Off Time | t _{so} | V _{IN} =5.0V, V _{MODE1} =V _{MODE2} =V _{MODE3} =V _{IN} , C _L =47μF, V _{OUT} =1.8V, V _{CE} =5.0V→0.0V Time from V _{CE} =0.0V to V _{OUT} =0.2V | 0.05 | 0.15 | 0.20 | ms | ① |
| C _L Discharge | R _{DCHG} | V _{IN} =5.0V, V _{CE} =0.0V, V _{FB} =0.66V, V _{MODE1} =V _{MODE2} =V _{IN} , V _{MODE3} =0.0V, V _{OUT} =0.2V | - | 65 | 130 | Ω | ⑧ |
| Hiccup wait time | t _{HW} | V _{IN} =5.0V, V _{CE} =V _{MODE1} =V _{MODE2} =V _{IN} , V _{MODE3} =0.0V, C _{SS} =3300pF, V _{OUT} =0.0V, Time from the oscillation stop until the oscillation start | 1.0 | 2.5 | 5.0 | ms | ① |
| MODE1 "H" Voltage | V _{MODE1H} | Applied voltage to V _{MODE1} , Voltage for PWM Control | 1.4 | - | 5.5 | V | ① |
| MODE1 "L" Voltage | V _{MODE1L} | Applied voltage to V _{MODE1} , Voltage for PWM/PFM automatic control | AGND | - | 0.5 | V | ① |
| MODE2 "H" Voltage | V _{MODE2H} | Applied voltage to V _{MODE2} , Voltage for HICCUP MODE | 1.4 | - | 5.5 | V | ④ |
| MODE2 "L" Voltage | V _{MODE2L} | Applied voltage to V _{MODE2} , Voltage for SHORT PROTECTION with LATCH | AGND | - | 0.5 | V | ④ |
| MODE3 "H" Voltage | V _{MODE3H} | Applied voltage to V _{MODE3} , Voltage for C _L Auto-Discharge with SOFT-OFF | 1.4 | - | 5.5 | V | ① |
| MODE3 "L" Voltage | V _{MODE3L} | Applied voltage to V _{MODE3} , Voltage for C _L Auto-Discharge | AGND | - | 0.5 | V | ① |
| MODE1 "H" Current | I _{MODE1H} | V _{IN} =5.5V, V _{CE} =0.0V, V _{MODE1} =5.5V, V _{MODE2} =5.5V, V _{MODE3} =5.5V | -0.1 | - | 0.1 | μA | ⑤ |
| MODE1 "L" Current | I _{MODE1L} | V _{IN} =5.5V, V _{CE} =0.0V, V _{MODE1} =0.0V, V _{MODE2} =0.0V, V _{MODE3} =0.0V | -0.1 | - | 0.1 | μA | ⑤ |
| MODE2 "H" Current | I _{MODE2H} | V _{IN} =5.5V, V _{CE} =0.0V, V _{MODE1} =5.5V, V _{MODE2} =5.5V, V _{MODE3} =5.5V | -0.1 | - | 0.1 | μA | ⑤ |
| MODE2 "L" Current | I _{MODE2L} | V _{IN} =5.5V, V _{CE} =0.0V, V _{MODE1} =0.0V, V _{MODE2} =0.0V, V _{MODE3} =0.0V | -0.1 | - | 0.1 | μA | ⑤ |
| MODE3 "H" Current | I _{MODE3H} | V _{IN} =5.5V, V _{CE} =0.0V, V _{MODE1} =5.5V, V _{MODE2} =5.5V, V _{MODE3} =5.5V | -0.1 | - | 0.1 | μA | ⑤ |
| MODE3 "L" Current | I _{MODE3L} | V _{IN} =5.5V, V _{CE} =0.0V, V _{MODE1} =0.0V, V _{MODE2} =0.0V, V _{MODE3} =0.0V | -0.1 | - | 0.1 | μA | ⑤ |
| CE "H" Voltage | V _{CEH} | V _{IN} =5.0V, V _{OUT} =V _{FB} =0.54V V _{MODE1} =0.0V, V _{MODE2} =V _{IN} , V _{MODE3} =0.0V Applied voltage to V _{CE} Voltage changes Lx to "H" level ^{(*)5} | 1.4 | - | 5.5 | V | ④ |
| CE "L" Voltage | V _{CEL} | V _{IN} =5.0V, V _{OUT} =V _{FB} =0.54V V _{MODE1} =0.0V, V _{MODE2} =V _{IN} , V _{MODE3} =0.0V Applied voltage to V _{CE} Voltage changes Lx to "L" level ^{(*)5} | AGND | - | 0.5 | V | ④ |
| CE "H" Current | I _{CEH} | V _{IN} =5.5V, V _{CE} =5.5V, V _{MODE1} =5.5V, V _{MODE2} =5.5V, V _{MODE3} =5.5V, | -0.1 | - | 0.1 | μA | ⑤ |
| CE "L" Current | I _{CEL} | V _{IN} =5.5V, V _{CE} =0.0V, V _{MODE1} =0.0V, V _{MODE2} =0.0V, V _{MODE3} =0.0V | -0.1 | - | 0.1 | μA | ⑤ |
| Short Protection Threshold Voltage | V _{SHORT} | V _{IN} =5.0V, V _{CE} =V _{IN} , V _{FB} =0.54V V _{MODE1} =V _{IN} , V _{MODE2} =0.0V, V _{MODE3} =0.0V Sweeping V _{OUT} , voltage which Lx becomes "L" level ^{(*)5} | 0.10 | 0.20 | 0.50 | V | ④ |

Unless otherwise stated, V_{IN}=5.0V, V_{CE}=5.0V, V_{MODE1}=0.0V, V_{MODE2}=0.0V, V_{MODE3}=0.0V

^{(*)1} When the difference between the input and the output is small, 100% duty might come up and internal control circuits keep Pch MOS driver turning on even though the output current is not so large.

If current is further pulled from this state, output voltage will decrease because of Pch MOS driver ON resistance.

^{(*)2} Including UVLO detect voltage, hysteresis operating voltage range for UVLO release voltage.

^{(*)3} EFFI = [(output voltage × output current) ÷ (input voltage × input current)] × 100

^{(*)4} R_{LXH} = (V_{IN} - Lx pin measurement voltage) / 100mA, R_{LXL} = Lx pin measurement voltage / 100mA

^{(*)5} "H" = V_{IN} - 1.2V ~ V_{IN}, "L" = -0.1V ~ +0.1V

^{(*)6} When temperature is high, a current of approximately 150μA (maximum) may leak.

^{(*)7} When temperature is high, a current of approximately 50μA (maximum) may leak.

^{(*)8} Current limit denotes the level of detection at peak of Pch MOS driver Tr. current.

^{(*)9} Design value

TEST CIRCUITS

< Circuit No.① >

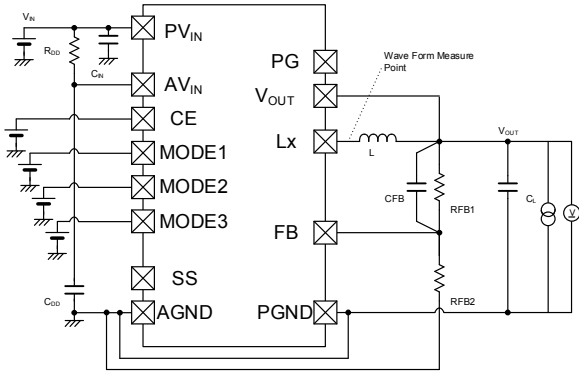

※ External Components
 C_N : 47 μ F (ceramic) C_{FB} : 1500pF
 C_L : 47 μ F (ceramic) R_{FB1} : 36k Ω
 R_{OD} : 100 Ω R_{FB2} : 18k Ω
 C_{OS} : 2.2 μ F
 L (fosc=1.2MHz) : 0.56 μ H (XAL6030)
 L (fosc=3.0MHz) : 0.22 μ H (XAL4020)

< Circuit No.② >

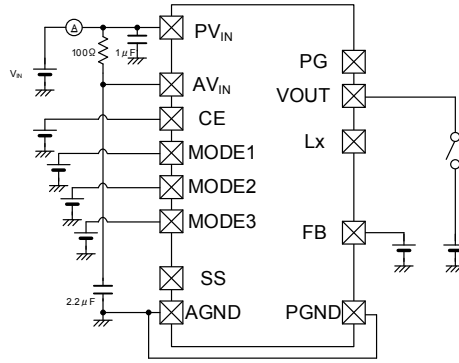

< Circuit No.③ >

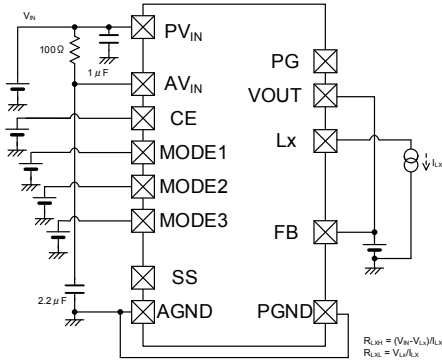

$R_{LxH} = (V_{IN} - V_{Lx}) / I_{Lx}$
 $R_{LxL} = V_{Lx} / I_{Lx}$

< Circuit No.④ >

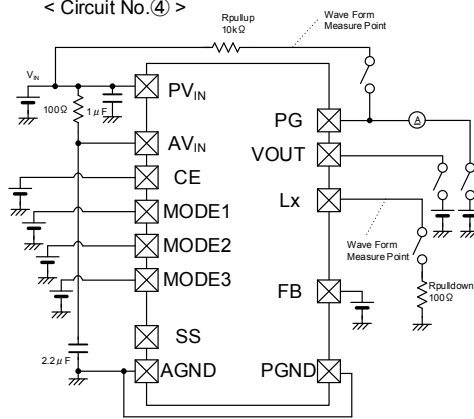

< Circuit No.⑤ >

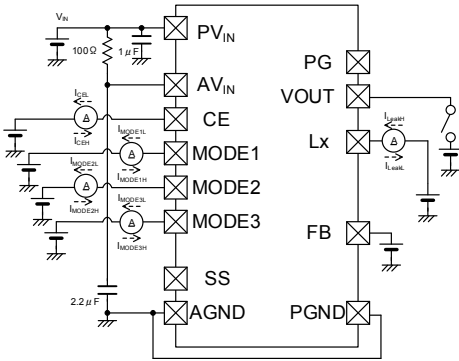

< Circuit No.⑥ >

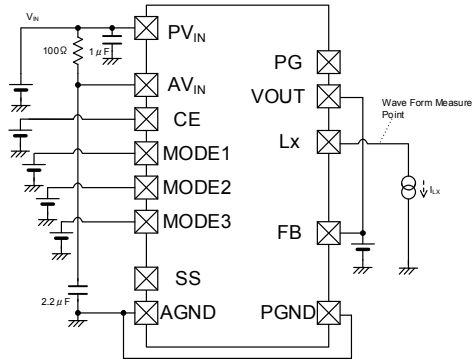

< Circuit No.⑦ >

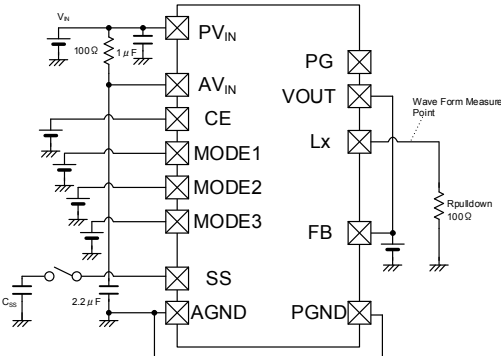

< Circuit No.⑧ >

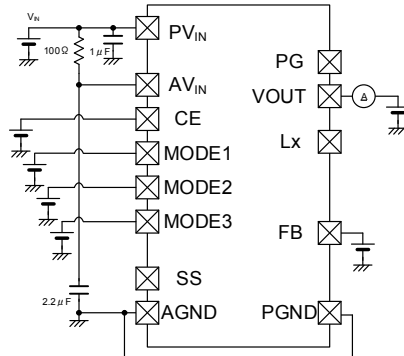

TYPICAL APPLICATION CIRCUIT

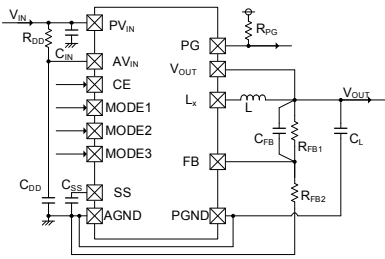

【Typical Examples】 $f_{osc} = 1.2\text{MHz}$

| | MANUFACTURER | PRODUCT NUMBER | VALUE | SIZE (L × W × T) |
|-----|------------------|-----------------|---------------------|-----------------------|
| L | Sunlord | MWSA0518-R56MT | 0.56μH | 5.4 × 5.2 × 1.8(mm) |
| | | MWSA0603-R56MT | 0.56μH | 7.1 × 6.6 × 3.0(mm) |
| | Coilcraft | XAL6030 - 561ME | 0.56μH | 6.36 × 6.56 × 3.1(mm) |
| | | XFL7015 - 471ME | 0.47μH | 7.5 × 7.5 × 1.5(mm) |
| TDK | SPM6530T-R47M170 | 0.47μH | 7.1 × 6.5 × 3.0(mm) | |

【Typical Examples】 $f_{osc} = 3.0\text{MHz}$

| | MANUFACTURER | PRODUCT NUMBER | VALUE | SIZE (L × W × T) |
|---|----------------------|------------------|--------|-----------------------|
| L | Sunlord | MWSA0624-R22MT | 0.22μH | 7.1 × 6.6 × 2.4(mm) |
| | TOKYOCOILENGINEERING | MCP0420-R22S | 0.22μH | 4.1 × 4.1 × 2.1(mm) |
| | Würth Elektronik | 744373240022 | 0.22μH | 4.45 × 4.06 × 1.8(mm) |
| | Coilcraft | XAL4020 - 221ME | 0.22μH | 4.0 × 4.0 × 2.1(mm) |
| | | XFL7015 - 251ME | 0.25μH | 7.5 × 7.5 × 1.5(mm) |
| | TDK | SPM6530T-R25M230 | 0.25μH | 7.1 × 6.5 × 3.0(mm) |

【Typical Examples】 ^(*) $f_{osc} = 1.2\text{MHz}$, $f_{osc} = 3.0\text{MHz}$

| | MANUFACTURER | PRODUCT NUMBER | VALUE | SIZE (L × W × T) |
|-----------------|-----------------|-------------------|---------------------------|-----------------------|
| C _{IN} | murata | GRM31CR61A476ME15 | 47μF/10V | 3.2 × 1.6 × 1.6(mm) |
| | TAIYO YUDEN | LMK316ABJ476ML | 47μF/10V | 3.2 × 1.6 × 1.6(mm) |
| | TDK | C3216X6S1A476M | 47μF/10V | 3.2 × 1.6 × 1.6(mm) |
| C _L | murata | GRM31CR60J476ME19 | 47μF/6.3V ^{(*)2} | 3.2 × 1.6 × 1.6(mm) |
| | | GRM32ER71A476KE15 | 47μF/10V ^{(*)2} | 3.2 × 2.5 × 2.5(mm) |
| | TAIYO YUDEN | JMK316ABJ476ML | 47μF/6.3V ^{(*)2} | 3.2 × 1.6 × 1.6(mm) |
| | | LMK325B7476KM | 47μF/10V ^{(*)2} | 3.2 × 2.5 × 2.5(mm) |
| | TDK | C3216X6S0J476M | 47μF/6.3V ^{(*)2} | 3.2 × 1.6 × 1.6(mm) |
| | C _{SS} | | | 330pF ^{(*)3} |
| R _{DD} | | | 100Ω | |
| C _{DD} | murata | GRM155R61A225KE95 | 2.2μF/10V | 1.0 × 0.5 × 0.5(mm) |
| | TAIYO YUDEN | LMK105BJ225MV | 2.2μF/10V | 1.0 × 0.5 × 0.5(mm) |
| R _{PG} | | | 100kΩ | |

^{(*)1} Select components appropriate to the usage conditions (ambient temperature, input & output voltage).

^{(*)2} Regarding the value of C_L, please refer to Fig.1, Fig.2

^{(*)3} Can also be used without C_{SS} (SS pin OPEN). When used without C_{SS}, the IC starts at the soft start time set internally.

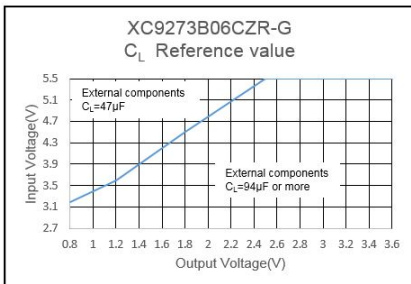

Fig.1: XC9273B06CZR-G C_L Value

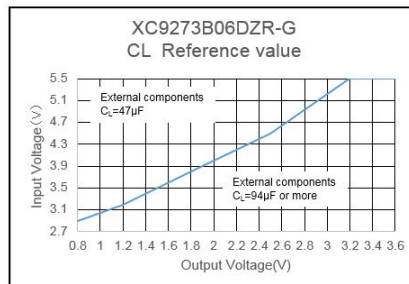

Fig.2: XC9273B06DZR-G C_L Value

TYPICAL APPLICATION CIRCUIT(Continued)

< Output voltage setting >

The output voltage can be set by adding an external dividing resistor. The output voltage is determined by the equation below based on the values of R_{FB1} and R_{FB2} .

$$V_{OUT} = 0.6 \times (R_{FB1} + R_{FB2}) / R_{FB2}$$

with $R_{FB1}, R_{FB2} \leq 100k\Omega$

Adjust the value of the phase compensation speed-up capacitor. Adjust the C_{FB} value so that $f_{zfb} = 1 / (2 \times \pi \times C_{FB} \times R_{FB1})$ is about 3kHz

【Setting Example】

When $R_{FB1} = 36k\Omega$, $R_{FB2} = 18k\Omega$, $V_{OUT} = 0.6 \times (36k\Omega + 18k\Omega) / 18k\Omega = 1.8V$

When $C_{FB} = 1500pF$, $f_{zfb} = 1 / (2 \times \pi \times 1500pF \times 36k\Omega) = 2.95kHz$

< Inductance value setting >

In the XC9273 series, it is optimum to set an inductance value within the range below based on the set frequency.

f_{OSCSET} : Set frequency

| f_{OSCSET} | Inductance value |
|--------------|-----------------------------|
| 3.0MHz | 0.22 μ H ~ 0.25 μ H |
| 1.2MHz | 0.47 μ H ~ 0.56 μ H |

< Soft-start function >

The soft start time of the XC9273 series can be adjusted externally (SS pin). The soft start time is the time from the start of V_{CE} until the output voltage reaches 90% of the set voltage. The soft start time depends on the external capacitance C_{SS} , and is determined by the equation below.

$$t_{SS2}(ms) = 1.5 \times C_{SS} / I_{SS}$$

C_{SS} : External capacitance (nF)

I_{SS} : 2.0 (μ A)

* Note that the value of the soft start time t_{SS2} varies depending on the effective capacitance value of the delay capacitance C_{SS} and I_{SS} .

【Calculation Example】

When $C_{SS} = 3.3nF$ $t_{SS2} = 1.5 \times 3.3 / \{2\mu A\} = 2.475ms$

The minimum value t_{SS2} of the soft-start time is set internally.

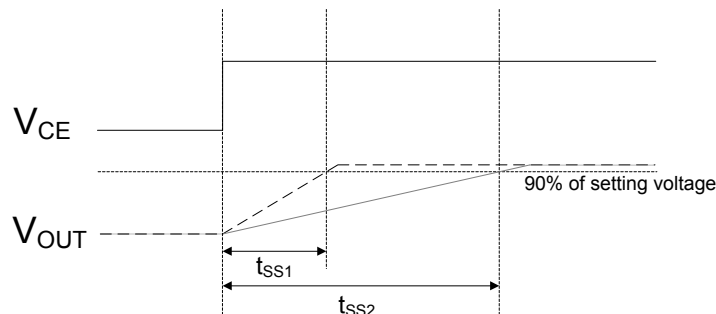

■ OPERATIONAL EXPLANATION

The XC9273 series consists of a reference voltage source, error amplifier, comparator, phase compensation, minimum on time generation circuit, output voltage adjustment resistors, P-channel MOS driver transistor, N-channel MOS switching transistor for the synchronous switch, current limiter circuit, UVLO circuit, thermal shutdown circuit, short protection circuit, PWM/PFM selection circuit and others. (See the BLOCK DIAGRAM below.)

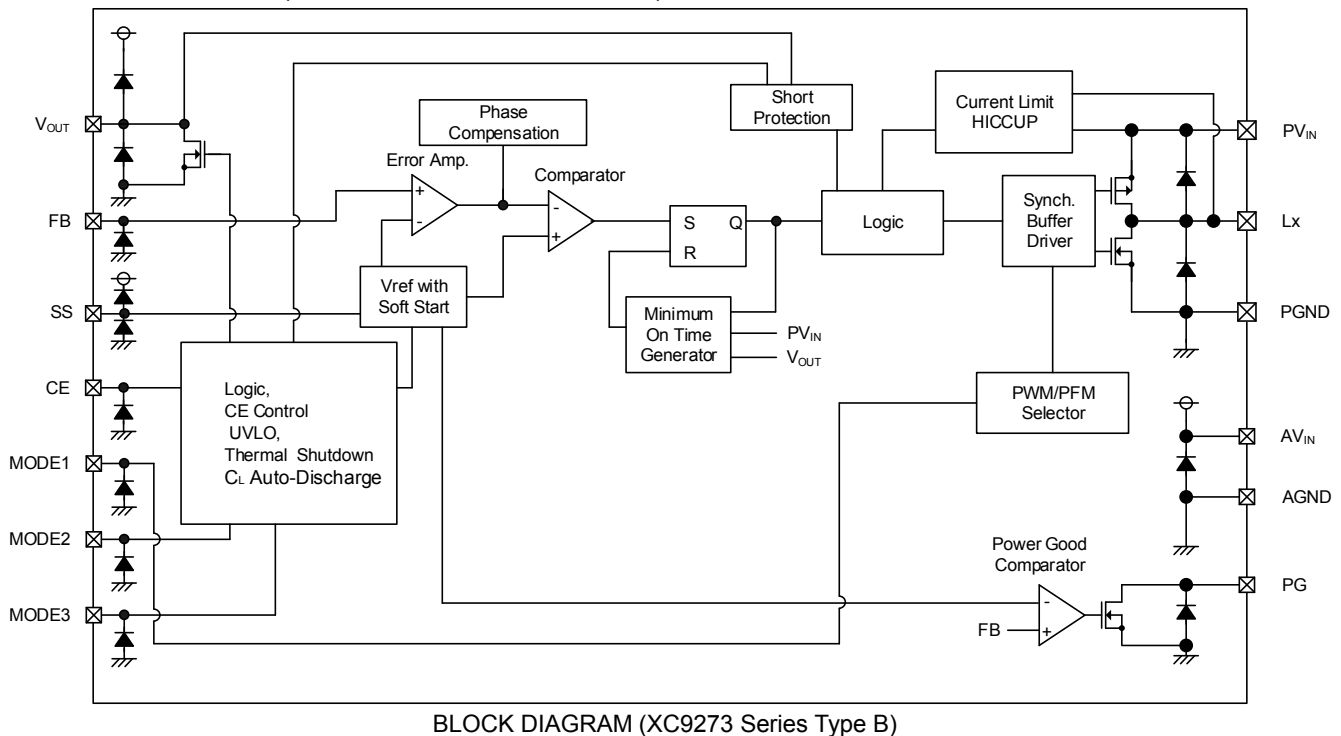

The method is HiSAT-COT (High Speed circuit Architecture for Transient with Constant On Time) control, which features on time control method and a fast transient response that also achieves low output voltage ripple.

The on time (t_{on}) is determined by the input voltage and output voltage, and turns on the Pch MOS driver T_r for a fixed time. During the off time (t_{off}), the voltage is generated by resistor division with resistors R_{FB1} and R_{FB2} . The voltage is compared to the reference voltage by the error amp, and the error amp output is phase compensated and sent to the comparator. The comparator compares this signal to the reference voltage, and if the signal is lower than the reference voltage, sets the SR latch. On time then resumes. By doing this, PWM operation takes place with the off time controlled to the optimum duty ratio and the output voltage is stabilized. The phase compensation circuit optimizes the frequency characteristics of the error amp, and generates a ramp wave similar to the ripple voltage that occurs in the output to modulate the output signal of the error amp. This enables a stable feedback system to be obtained even when a low ESR capacitor such as a ceramic capacitor is used, and a fast transient response and stabilization of the output voltage are achieved.

< Minimum on time generation circuit >

Generates an on time that depends on the input voltage and output voltage (t_{on}). The on time is set as given by the equations below.

$$f_{OSC} = 1.2 \text{ MHz}$$

$$t_{on} (\mu\text{s}) = V_{OUT} / V_{IN} \times 0.833$$

$$f_{OSC} = 3.0 \text{ MHz}$$

$$t_{on} (\mu\text{s}) = V_{OUT} / V_{IN} \times 0.333$$

< Switching frequency >

The switching frequency can be obtained from the on time (t_{on}), which is determined by the input voltage and output voltage, and the PWM controlled off time (t_{off}) as given by the equation below.

$$f_{OSC} (\text{MHz}) = V_{OUT}(V) / (V_{IN}(V) \times t_{on}(\mu\text{s}))$$

< 100% duty cycle mode >

When the load current is heavy and the voltage difference between input voltage and output voltage is small, 100% duty cycle mode is activated and it keeps the Pch MOS driver T_r keep on. 100% duty cycle mode attains a high output voltage stability and a high-speed response under all load conditions, from light to heavy, even in conditions where the dropout voltage is low.

■ OPERATIONAL EXPLANATION (Continued)

< Error amp >

The error amp monitors the output voltage. The voltage divided by the external R_{FB1} and R_{FB2} resistors is a feedback voltage for Error Amp. and compared to the reference voltage. The output voltage of the error amp becomes higher when the feedback voltage is higher than the reference voltage. The frequency characteristics of the error amp are optimized internally.

< Reference voltage source, soft start function >

The reference voltage forms a reference that is used to stabilize the output voltage of the IC.

After "H" level is fed to CE pin, the reference voltage connected to the error amp increases linearly during the soft start interval. This allows the voltage divided by the external R_{FB1} and R_{FB2} resistors and the reference voltage to be controlled in a balanced manner, and the output voltage rises in proportion to the rise of the reference voltage. This operation prevents rush input current and enables the output voltage to rise smoothly.

If the output voltage does not reach the set output voltage within the soft start time, for example a case when the load is heavy or a large capacity output capacitor is connected, the balance between the feedback voltage and the reference voltage is lost, however, the current limit function is activated in order to prevent an excessive increase of input current, enabling a smooth rise of the output voltage.

< Control system selection circuit >

XC9273 series is selectable on the control method between PWM control and PWM/PFM auto switching control by using MODE1 pin. When "H" level is fed to MODE1 pin, XC9273 works with PWM control, whereas when "L" level is fed to MODE1 pin, it works with PWM/PFM auto switching control.

Under PWM control, XC9273 works with the continuous conduction mode (CCM) and ON-duty is decided based on the relationship between the input voltage and the output voltage regardless the output current, and the switching frequency is stable.

On the other hand, under PWM/PFM auto switching control, XC9273 can work with the discontinuous conduction mode (DCM) when the output current is low and the switching frequency varies to lower frequency so that the switching loss reduces and, as a result, the efficiency is improved. MODE1 pin has CMOS input configuration and the sink current is 0 μ A.

< CE function >

Operation starts when "H" voltage is input into the CE pin. The IC can be put in the shutdown state by inputting "L" voltage into the CE pin. In the shutdown state, the supply current of the IC is 0 μ A (TYP.), and the Pch MOS driver Tr. And Nch MOS switch Tr. for synchronous rectification turn off. The CE pin is a CMOS input and the sink current is 0 μ A.

< UVLO Circuit >

When the AV_{IN} voltage becomes 2.40V (TYP.) or lower, the Pch MOS driver transistor output driver transistor is forced OFF to prevent false pulse output caused by unstable operation of the internal circuitry. When the AV_{IN} pin voltage becomes 2.50V (TYP.) or higher, switching operation takes place. By releasing the UVLO function, the IC performs the soft start function to initiate output startup operation. The UVLO circuit does not cause a complete shutdown of the IC, but causes pulse output to be suspended; therefore, the internal circuitry remains in operation.

< Thermal Shutdown >

For protection against heat damage of the ICs, thermal shutdown function monitors chip temperature. The thermal shutdown circuit starts operating and the Pch MOS driver and Nch MOS driver transistor will be turned off when the chip's temperature reaches 150°C. When the temperature drops to 120°C or less after shutting of the current flow, the IC performs the soft-start function to initiate output startup operation.

< Short-circuit protection function >

Short-circuit protection circuit protects the device that is connected to this product and to the input/output in situations such as when the output is accidentally shorted to GND. The short-circuit protection circuit monitors the output voltage, and when the output voltage falls below the short-circuit protection threshold voltage, it turns off the Pch MOS driver Tr and latches it. Once in the latched state, operation is resumed by turning off the IC from the CE pin and then restarting, or by re-input into the V_{IN} pin.

< Hiccup >

Hiccup is one of the means to protect the IC and the device connected to the IC from being damaged by an excessive temperature rise caused by the overload state in the long time.

- ① When the load current reaches the current limit, IC will be turned off.
- ② The IC protects itself from being damaged by the heat by maintaining the off state for a constant time.
- ③ After a certain time in state ②, the IC resumes operation to check whether or not the over current condition is continuing.
- ④ If the over current state continues, the IC returns to ②. The IC restarts by a soft start if the overcurrent state is released.

■ OPERATIONAL EXPLANATION (Continued)

< C_L High Speed Discharge >

C_L High Speed Discharge can quickly discharge the electric charge at the output capacitor (C_L) via the Nch MOS switch transistor and auto-discharge resistance located between the V_{OUT} pin and the GND pin when “L” level signal is fed to CE pin and IC is disable. It can prevent a malfunction of the device connected to the output of XC9273 due to the stored electric charge at the output capacitor when XC9273 is disable.

$$V = V_{OUT(T)} \times e^{-t / \tau}$$

$$t = \tau \ln (V_{OUT(T)} / V)$$

V : Output voltage after discharge,

V_{OUT(T)} : Output voltage

t : Discharge time

τ : C_L × R_{DCHG}

C_L : Capacitance of Output capacitor

R_{DCHG} : C_L auto-discharge resistance,
but it depends on supply voltage.

Output Voltage Discharge characteristics
R_{DCHG} = 65Ω(TYP) C_L = 47μF

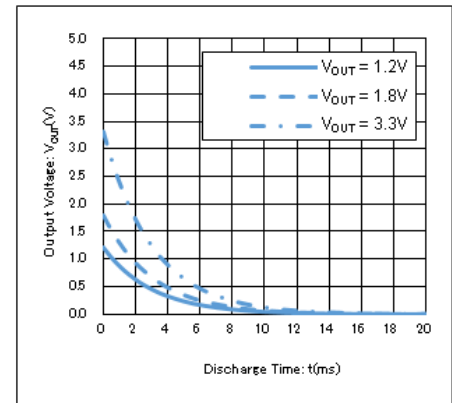

< Soft-off function >

When H level is fed to MODE3 pin and L level is fed to CE pin, a Soft-off function is activated.

The function can discharge the electric charge in the output capacitor much faster than C_L high speed discharge function because the function can turn on an internal Nch MOS switch which is for synchronous rectification originally and use it for the discharge. (Refer to a diagram below)

This function make a power-off sequence easier because it can prevent a device connected to the output of XC9273 from a malfunction caused by the stored electric charge in the output capacitor of XC9273 when it is disable.

Furthermore, the Soft-off function regenerates energy by Nch MOS switching Tr., and the input voltage rises by the regenerative energy. The rise voltage of the input voltage can be calculated with using the following equation, once the design has been completed, verification with actual components should be required.

【Equation】

The rise voltage of the input voltage = $(V_{OUT} - 0.2)^2 \times C_L / (2 \times V_{IN} \times C_{IN})$

V_{IN} : Input voltage

V_{OUT} : Output voltage

C_L : Actual capacitance value of an output Capacitor (C_L)

C_{IN} : Actual capacitance value of an input Capacitor (C_{IN})

【Calculation Example】

When V_{IN} = 5.0V, V_{OUT} = 1.8V, C_{IN} = 47μF, C_L = 47μF

The rise voltage of the input voltage = $(1.8 - 0.2)^2 \times (47 \times 10^{-6}) / (2 \times 5.0 \times (47 \times 10^{-6}))$
= 0.256V

Soft-off function vs C_L High Speed Discharge
C_L = 47μF

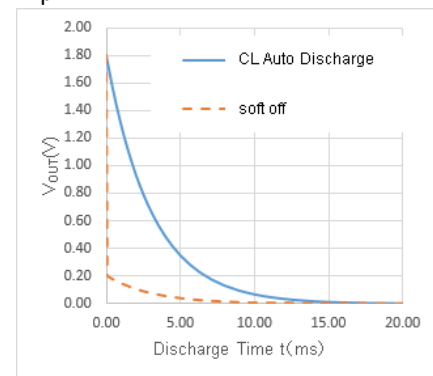

< Current Limit >

The current limiter circuit monitors the current flowing through the P-channel MOS driver transistor connected to the Lx pin.

When the driver current is bigger than a specific level, the current limit function operates to turn off the pulses from the Lx pin.

When the over current state is eliminated, the IC resumes its normal operation.

OPERATIONAL EXPLANATION (Continued)

<Power good>

Output state can be monitored using the power good function.

Connect pull-up resistor to a PG pin as its output configuration is Nch open drain.

The PG pin outputs "L" signal in the following cases.

case1: For V_{OUT} fluctuation

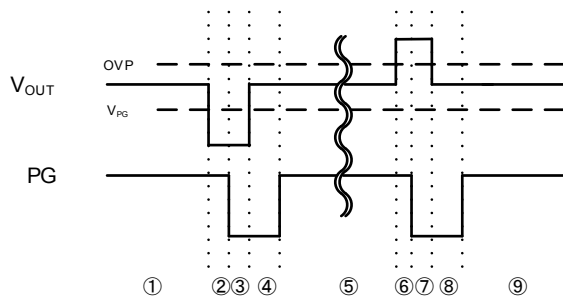

①The initial conditions, V_{OUT} is a stable state.

②When V_{OUT} falls to less than the threshold V_{PG} of the PG, PG system starts to count the internal delay (TYP=140 μ s).

③PG voltage goes down to GND level after the internal delay.

④After V_{OUT} goes up higher than the threshold V_{PG} , PG system starts to count the internal delay (TYP=180 μ s).

⑤PG voltage goes up to the pull up voltage after the internal delay.

⑥When V_{OUT} goes up to higher than threshold OVP , PG system starts to count the internal delay (TYP=140 μ s).

⑦PG voltage goes up to the pull up voltage after the internal delay.

⑧When V_{OUT} falls to less than the threshold OVP , PG system starts to count the internal delay (TYP=180 μ s).

⑨PG voltage goes up to the pull up voltage after the internal delay.

* When the FB voltage becomes 0.7V of the OVP threshold and V_{OUT} rises more than +17%, PG is made the GND level.

case2: For Soft-start function, Thermal Shutdown, Short-circuit protection function

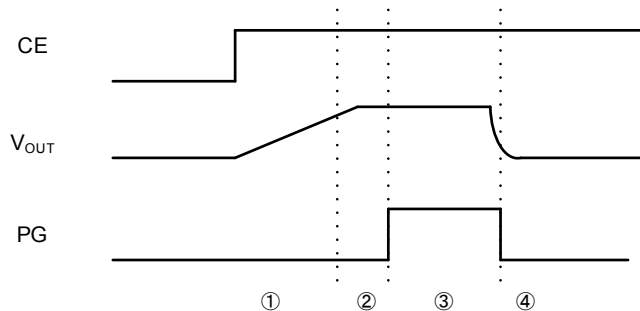

①Assume V_{IN} has been applied. When H level is fed to the CE pin, V_{OUT} will rise by using a Soft-start function. PG voltage is the GND level during Soft-start operation.

②After V_{OUT} goes up to 90% of the setting voltage, PG system starts to count the internal delay (TYP=140 μ s).

③PG voltage goes up to the pull up voltage after the internal delay.

④When a short circuit comes at V_{OUT} or when thermal shut down is activated, PG voltage goes down to the GND level promptly without an internal delay.

■ OPERATIONAL EXPLANATION (Continued)

case3: For C_L High Speed Discharge (CE= "L" voltage)

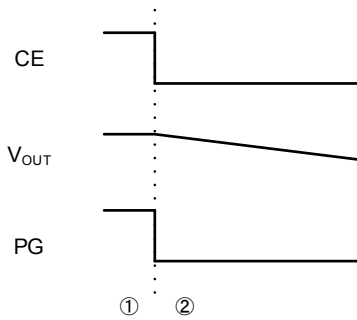

- ① The initial conditions, V_{OUT} is a stable state. Assume C_L high speed Discharge is activated by using MODE3 pin.
- ② L level is fed to CE pin and then XC9273 is in a standby state. Therefore V_{OUT} begins to fall down by a C_L High Speed Discharge. In this case, PG voltage goes down to GND level promptly.

case4: For Soft-off function (CE= "L" voltage)

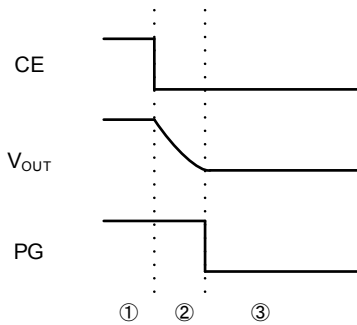

- ① The initial conditions, V_{OUT} is a stable state. Assume Soft-off function is activated by using MODE3 pin.
- ② L level is fed to CE pin and then XC9273 is in a standby state. Therefore V_{OUT} begins to fall down sharply by soft-off function. In this case, PG voltage goes down to GND level ($V_{OUT} = 0.2V$ or less) after soft-off function is completed.

NOTE ON USE

- 1) For the phenomenon of temporal and transitional voltage decrease or voltage increase, the IC may be damaged or deteriorated if IC is used beyond the absolute MAX. specifications.
- 2) Spike noise and ripple voltage arise in a switching regulator as with a DC/DC converter. These are greatly influenced by external component selection, such as the coil inductance, capacitance values, and board layout of external components. Once the design has been completed, verification with actual components should be done.
- 3) The DC/DC converter characteristics depend greatly on the externally connected components as well as on the characteristics of this IC, so refer to the specifications and standard circuit examples of each component when carefully considering which components to select. Be especially careful of the capacitor characteristics and use B characteristics (JIS standard) or X7R, X5R (EIA standard) ceramic capacitors.
If the capacitance value is not sufficient by degrading CL due to the low temp. Condition and DC bias feature, the duty cycle might not be stable. Add capacitance value for CL if necessary.
- 4) Make sure that the PCB GND traces are as thick and wide as possible. The PGND pin and AGND pin fluctuation caused by high ground current at the time of switching may result in instability of the IC. Therefore, the GND traces close to the PGND pin and AGND pin are important.
- 5) Mount external components as close as possible to the IC. Keep the wiring short and thick to lower the wiring impedance.
- 6) A feature of HiSAT-COT control is that it controls the off time in order to control the duty, which varies due to the effects of power loss. In addition, changes in the on time due to 100% duty cycle mode are allowed. For this reason, caution must be exercised as the characteristics of the switching frequency will vary depending on the external component characteristics, board layout, input voltage, output voltage, load current and other parameters.
- 7) Due to propagation delay inside the product, the on time generated by the minimum on time generation circuit is not the same as the on time that is the ratio of the input voltage to the output voltage.
- 8) With regard to the current limiting value, the actual coil current may at times exceed the electrical characteristics due to propagation delay inside the product.
- 9) The CE pin is a CMOS input pin. Do not use with the pin open. If connecting to the input or ground, use the resistor not more than 1MΩ or less. To prevent malfunctioning of the device connected to this product or the input/output due to short circuiting between pins, it is recommended that a resistor be connected.
- 10) Regarding XC9273 which has PWM/PFM auto switching control method, it works with a discontinuous conduction mode at light loads, and in this case where the voltage difference between input voltage and output voltage is low or the coil inductance is higher than the value indicated in the standard circuit example, the coil current may reverse when the load is light, and thus pulse skipping will not be possible and light load efficiency will worsen.
- 11) When the voltage difference between input voltage and output voltage is low, the load stability feature may deteriorate.
- 12) Soft-off function regenerates energy by Nch MOS switching Tr. Additionally the input voltage rises by the regenerative energy. In this case, please note the input voltage not to exceed 5.5V. The Lx voltage may be beyond the absolute maximum ratings when the input voltage exceeds 5.5V.
The rise of input voltage can be suppressed by increasing C_{IN}. Please increase C_{IN} based on the following equation.
For your design, please evaluate this issue on your PCB and actual external components sufficiently.

【Equation】

$$C_{IN} > (V_{OUT} - 0.2)^2 \times C_L / (\Delta V_{IN} \times 2 \times V_{IN})$$

V_{IN}: Input voltage

ΔV_{IN}: (5.5 - V_{IN})

V_{OUT}: Output voltage

C_L: Actual capacitance value of an output Capacitor (C_L)

C_{IN}: Actual capacitance value of an input Capacitor (C_{IN})

【Calculation Example】

When V_{IN}=5.0V, V_{OUT}=1.8V, C_L=47μF

ΔV_{IN}=(5.5-5.0)=0.5V

C_{IN}>(1.8-0.2)²×47/(0.5×2×5.0)

C_{IN}>24.064μF

- 13) Torex places an importance on improving our products and their reliability. We request that users incorporate fail-safe designs and post-aging protection treatment when using Torex products in their systems.

NOTE ON USE (Continued)

14) Instructions of pattern layouts

The operation may become unstable due to noise and/or phase lag from the output current when the wire impedance is high, please place the input capacitor(C_{IN}) and the output capacitor (C_L) as close to the IC as possible.

- (1) In order to stabilize V_{IN} voltage level, we recommend that a by-pass capacitor (C_{IN} , C_{DD}) to be connected as close as possible to the PV_{IN} & $PGND$ pins and the AV_{IN} & $AGND$ pins.
- (2) Please mount each external component as close to the IC as possible.
- (3) Wire external components as close to the IC as possible and use thick, short connecting traces to reduce the circuit impedance.
- (4) Make sure that the GND traces are as thick as possible, as variations in ground potential caused by high ground currents at the time of switching may result in instability of the IC.
- (5) This series' internal driver transistors bring on heat because of the output current and ON resistance of P-channel and N-channel MOS driver transistors. Please consider the countermeasures against heat if necessary.

< Reference pattern layout >

1st Layer

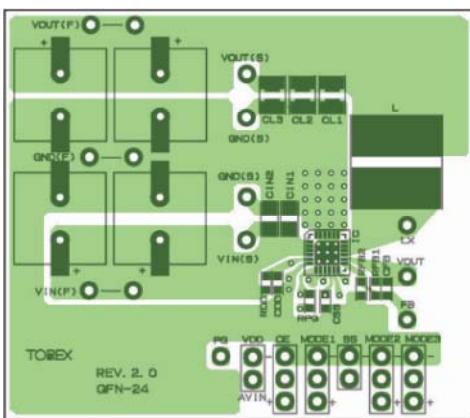

2nd Layer

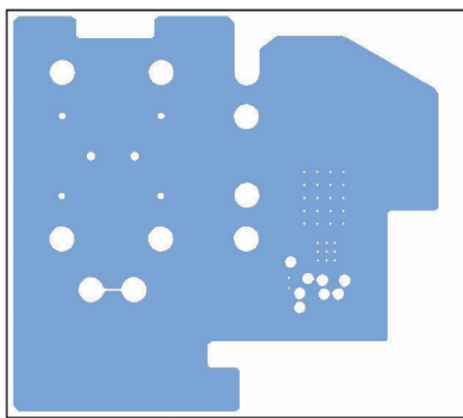

3rd Layer

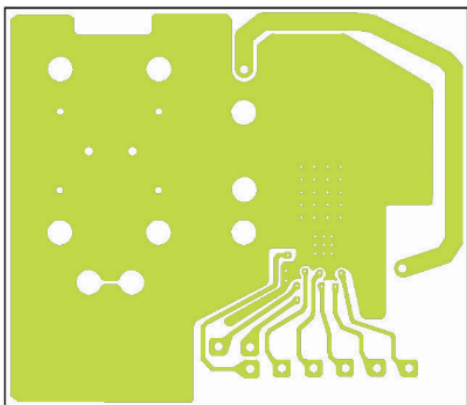

4th Layer

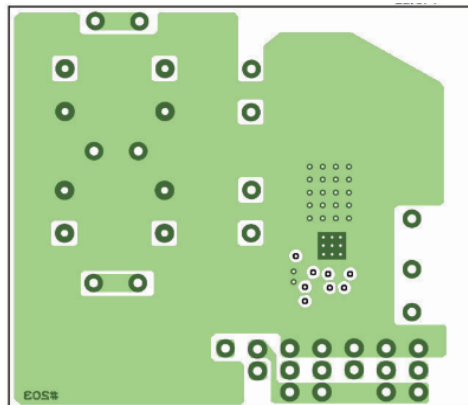

PCB mounted

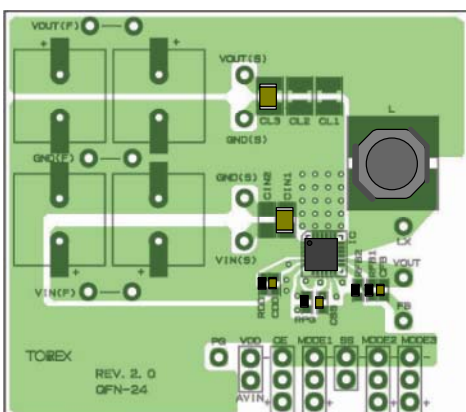

NOTE ON USE (Continued)

<Estimation for the power consumption>

The power loss of a total buck DC/DC system (P_all) is as follows.

$$\begin{aligned} P_{all} &= V_{IN} \times I_{IN} - V_{OUT} \times I_{OUT} \\ &= V_{OUT} \times I_{OUT} / \text{EFFI} - V_{OUT} \times I_{OUT} \\ &= -V_{OUT} \times I_{OUT} \times (1 - 1/\text{EFFI}) \end{aligned}$$

The power loss at a coil (P_coil) is as follows.

$$P_{coil} = I_{OUT}^2 \times \text{DCR}$$

DCR: The direct current resistance of a coil

The power loss at IC (P_IC) can be calculated by subtracting the power loss at a coil from the one of a total buck DC/DC system.

$$P_{IC} = P_{all} - P_{coil}$$

The temperature of IC (Tj) can be calculated by the function below.

R : Thermal resistance (°C/W)

$$T_j = T_a + R \times P_{IC}$$

The temperature resistance varies based on the power dissipation of a PC board and so on.

Please note that Tj should be lower than 125°C

<Calculation Example>

•Conditions :

V_{IN}=5.0V

V_{OUT}=1.8V

output current: I_{OUT}=3.0A

Efficiency: EFFI=87.58%

Thermal resistance R=34.8°C/W (Mount on a board)

DCR of a coil =5.81mΩ

$$\begin{aligned} \text{The power loss of a total buck DC/DC system (P}_{all}\text{)} &= -V_{OUT} \times I_{OUT} \times (1 - 1/\text{EFFI}) \\ &= -1.8 \times 3.0 (1 - 1/0.8758) \\ &\doteq 0.77 \text{ (W)} \end{aligned}$$

$$\begin{aligned} \text{The power loss at a coil (P}_{coil}\text{)} &= I_{OUT}^2 \times \text{DCR} \\ &= 3^2 \times 0.00581 = 0.052 \text{ (W)} \end{aligned}$$

$$\begin{aligned} \text{The power loss at IC (P}_{IC}\text{)} &= P_{all} - P_{coil} \\ &= 0.77 - 0.052 \\ &= 0.72 \text{ (W)} \end{aligned}$$

$$\begin{aligned} \text{The temperature of IC (T}_j\text{)} &= \text{The ambient temperature so that T}_j \text{ becomes } 125^\circ\text{C (T}_a\text{)} = T_j - R \times P_{IC} \\ &= 125 - 34.8 \times 0.72 \\ &= 99.9^\circ\text{C} \end{aligned}$$

In this case, under the condition above, the ambient temperature up to 99.9°C is acceptable

<Reference example>

T_a-I_{OUTMAX} feature example with QFN0404-24C recommendation PCB pattern

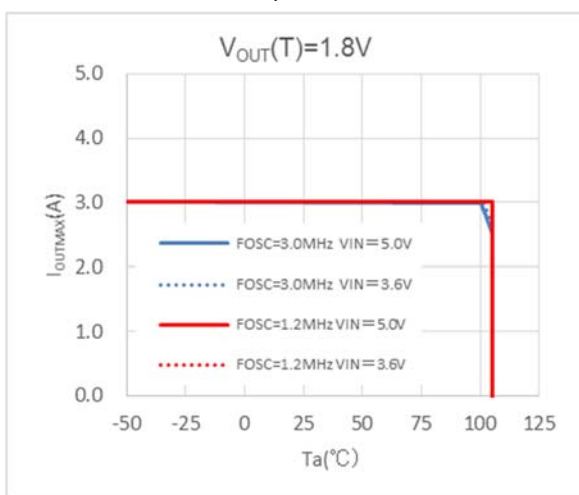

Measurement Condition

| | |
|------------------|---|
| Condition | : Mount on a board |
| Soldering | : Lead (Pb) free |
| Board | : Dimensions 53 x 54 mm (2862 mm ² in one side) (Reference pattern layout of QFN0404-24C) |
| Copper thickness | : 18.35μm(Cu) + 20μm(plating) = 38.35μm |
| Material | : Glass Epoxy (FR-4) |
| Thickness | : 1.2mm |
| Through-hole | : 30×0.3 Diameter 8×0.8 Diameter 30×1.0 Diameter |

TYPICAL PERFORMANCE CHARACTERISTICS

(1) Efficiency vs. Output Current

XC9273B06D ($V_{OUT}=1.2V$)

L = MWSA0624 (0.22 μ H), C_{IN} = 47 μ F (GRM31CR61A476ME15L)
 C_L = 47 μ F (GRM31CR60J476ME19L)
 RFB1=91k Ω , RFB2=91k Ω , CFB=560pF

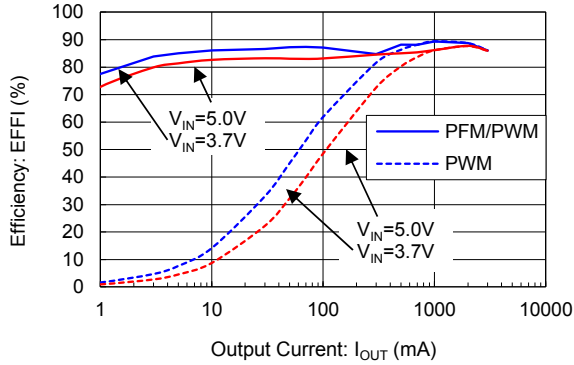

XC9273B06C ($V_{OUT}=1.2V$)

L = MWSA0603 (0.56 μ H), C_{IN} = 47 μ F (GRM31CR61A476ME15L)
 C_L = 47 μ F (GRM31CR60J476ME19L)
 RFB1=91k Ω , RFB2=91k Ω , CFB=560pF

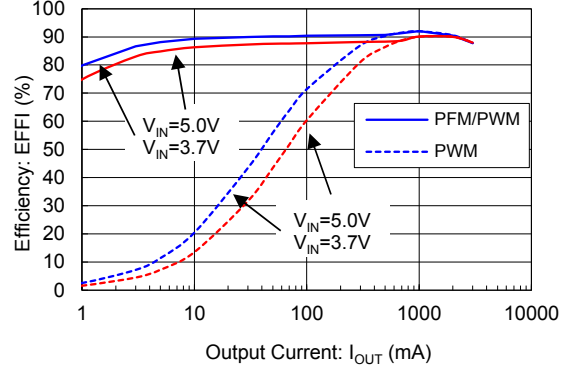

XC9273B06D ($V_{OUT}=1.8V$)

L = MWSA0624 (0.22 μ H), C_{IN} = 47 μ F (GRM31CR61A476ME15L)
 C_L = 47 μ F (GRM31CR60J476ME19L)
 RFB1=36k Ω , RFB2=18k Ω , CFB=1500pF

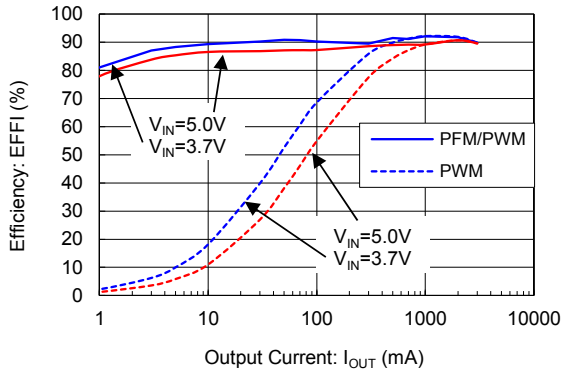

XC9273B06C ($V_{OUT}=1.8V$)

L = MWSA0603 (0.56 μ H), C_{IN} = 47 μ F (GRM31CR61A476ME15L)
 C_L = 47 μ F (GRM31CR60J476ME19L)
 RFB1=36k Ω , RFB2=18k Ω , CFB=1500pF

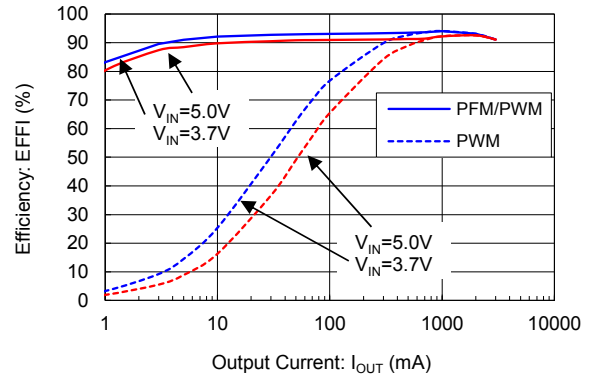

XC9273B06D ($V_{OUT}=3.3V$)

L = MWSA0624 (0.22 μ H), C_{IN} = 47 μ F (GRM31CR61A476ME15L)
 C_L = 94 μ F (GRM31CR60J476ME19Lx2)
 RFB1=68k Ω , RFB2=15k Ω , CFB=820pF

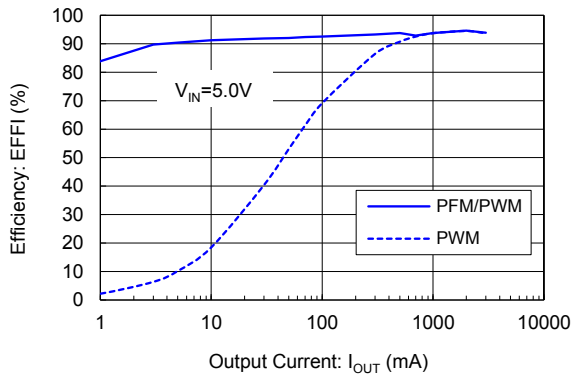

XC9273B06C ($V_{OUT}=3.3V$)

L = MWSA0603 (0.56 μ H), C_{IN} = 47 μ F (GRM31CR61A476ME15L)
 C_L = 94 μ F (GRM31CR60J476ME19Lx2)
 RFB1=68k Ω , RFB2=15k Ω , CFB=820pF

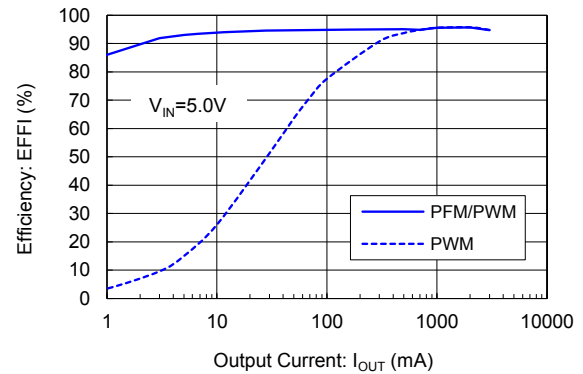

TYPICAL PERFORMANCE CHARACTERISTICS(Continued)

(2) Output Voltage vs. Output Current

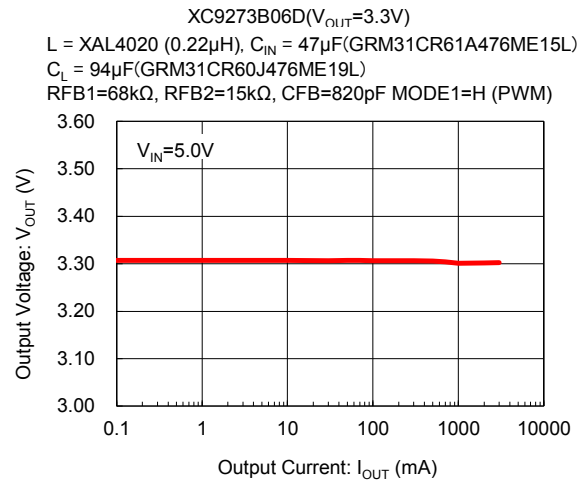
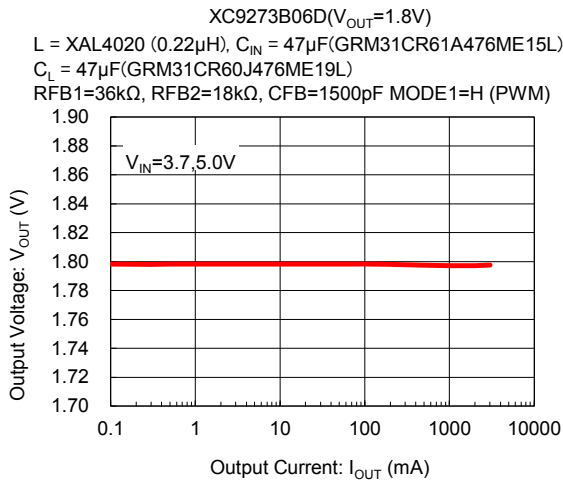

(3) Ripple Voltage vs. Output Current

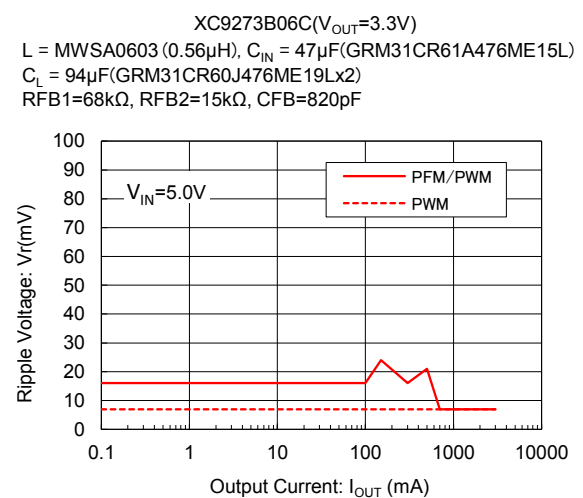
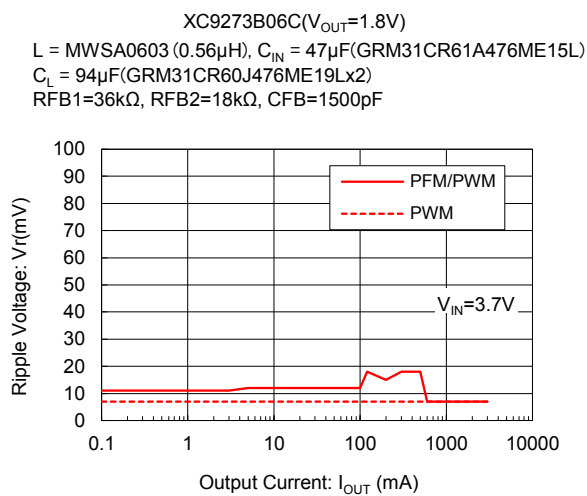
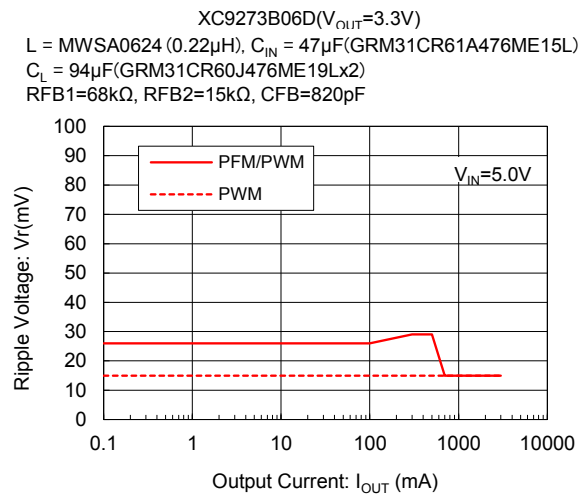
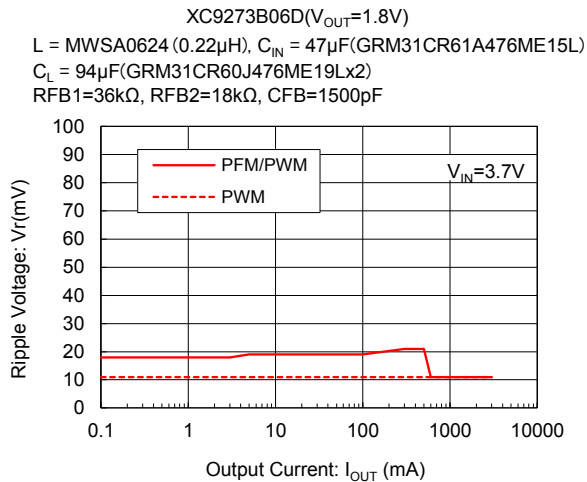

TYPICAL PERFORMANCE CHARACTERISTICS(Continued)

(4) Output Voltage vs. Ambient Temperature

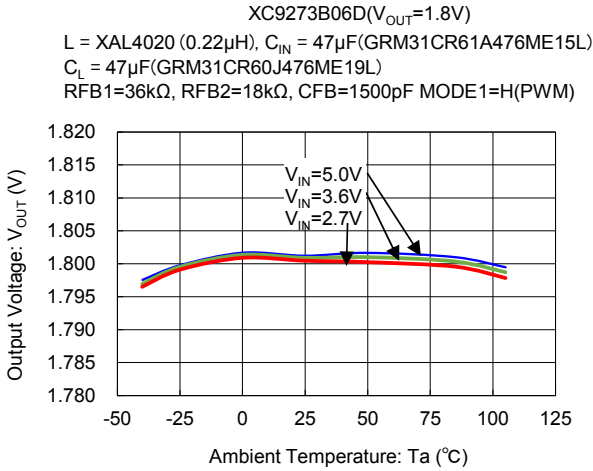

(5) UVLO Voltage vs. Ambient Temperature

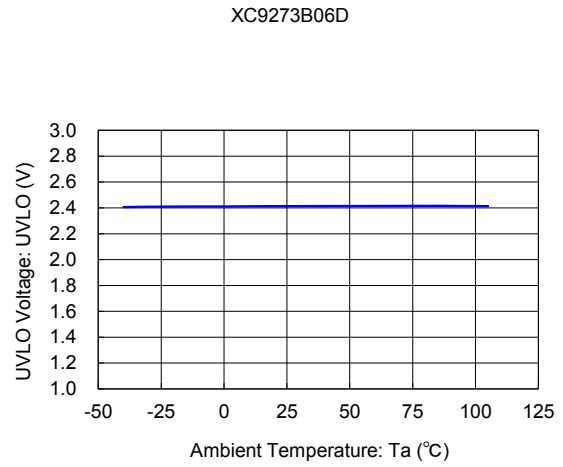

(6) Quiescent Current vs. Ambient Temperature

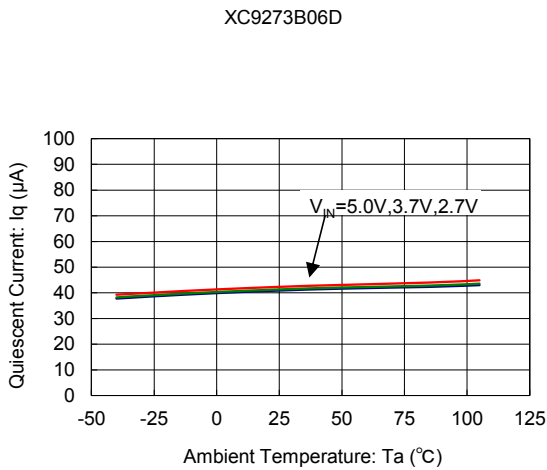

(7) Stand-by Current vs. Ambient Temperature

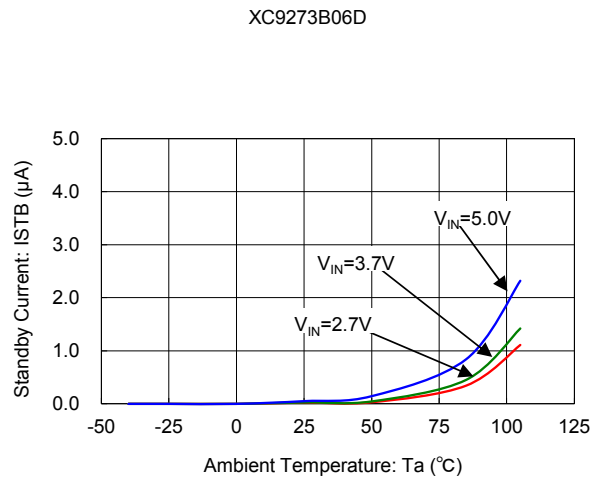

(8) Oscillation Frequency vs. Ambient Temperature

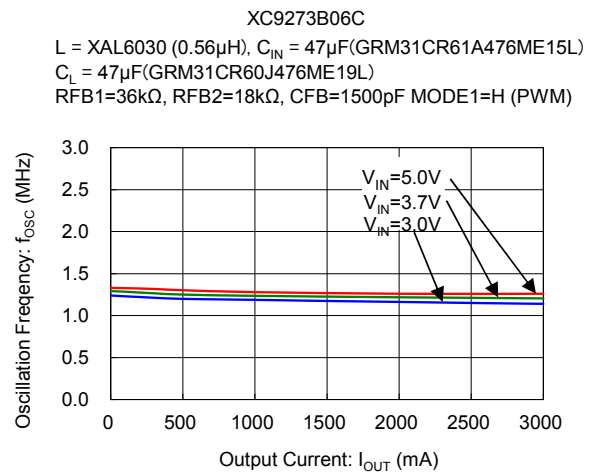
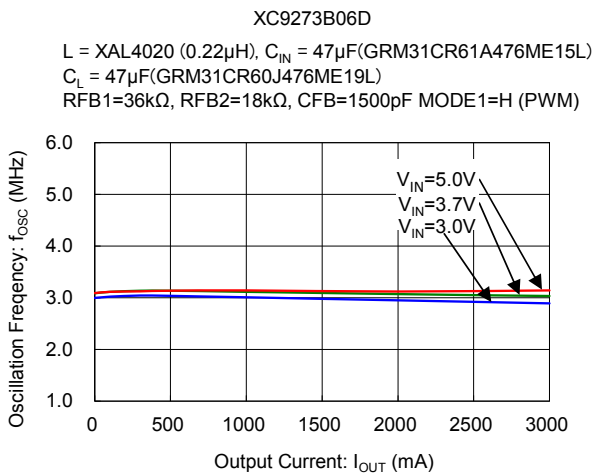

TYPICAL PERFORMANCE CHARACTERISTICS(Continued)

(9) Pch Driver ON Resistance vs. Ambient Temperature

XC9273B06D

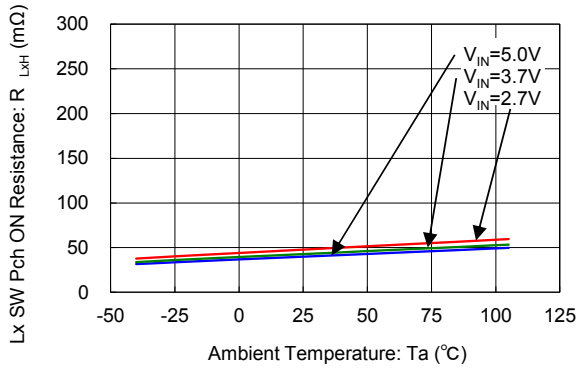

(10) Nch Driver ON Resistance vs. Ambient Temperature

XC9273B06D

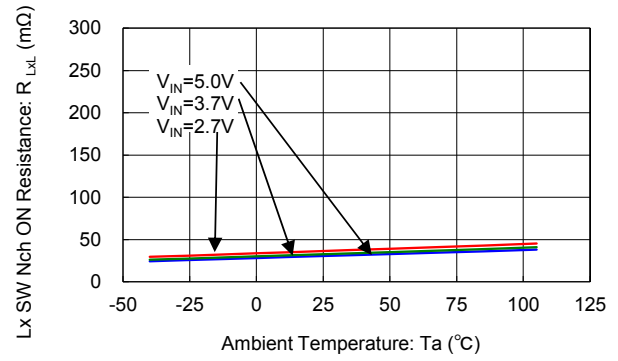

(11) LxSW"H" Leakage Current vs. Ambient Temperature

XC9273B06D

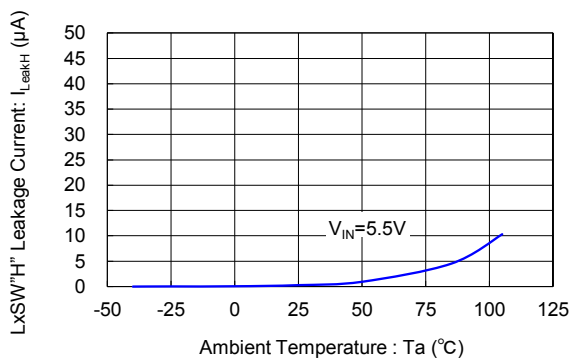

(12) LxSW"L" Leakage Current vs. Ambient Temperature

XC9273B06D

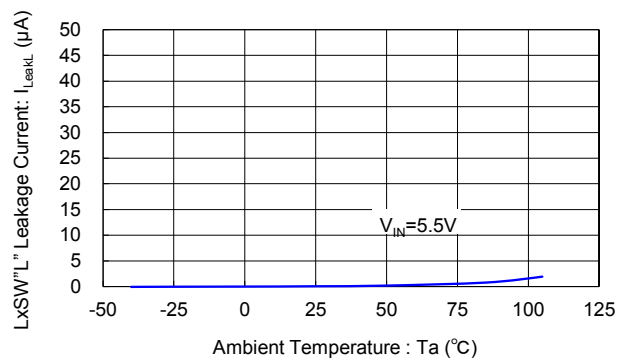

(13) CE"H" Voltage vs. Ambient Temperature

XC9273B06D

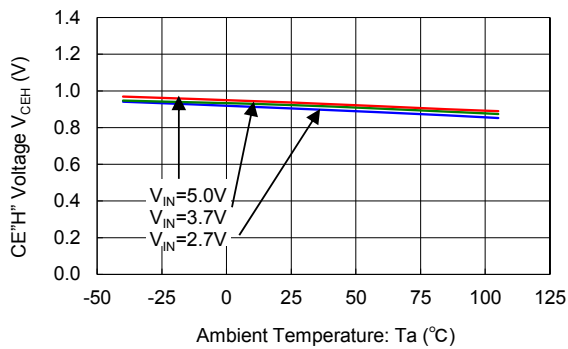

(14) CE"L" Voltage vs. Ambient Temperature

XC9273B06D

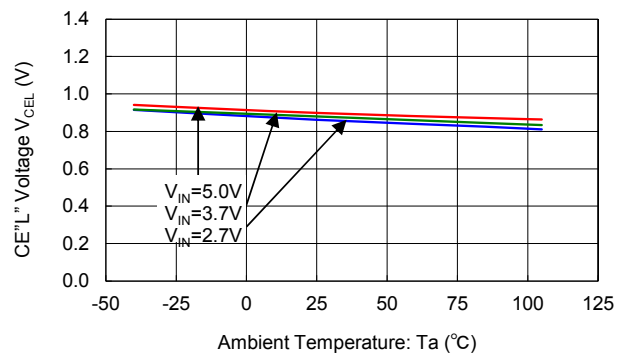

TYPICAL PERFORMANCE CHARACTERISTICS (Continued)

(15) MDOE1"H" Voltage vs. Ambient Temperature

XC9273B06D

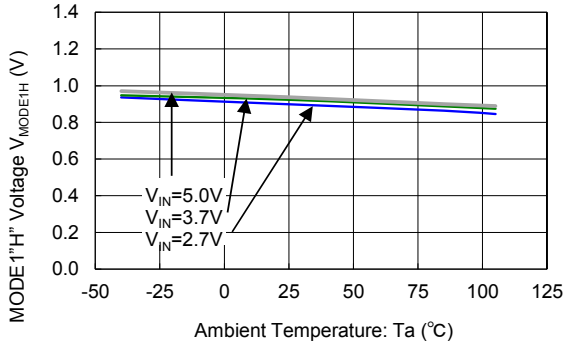

(16) MODE1"L" Voltage vs. Ambient Temperature

XC9273B06D

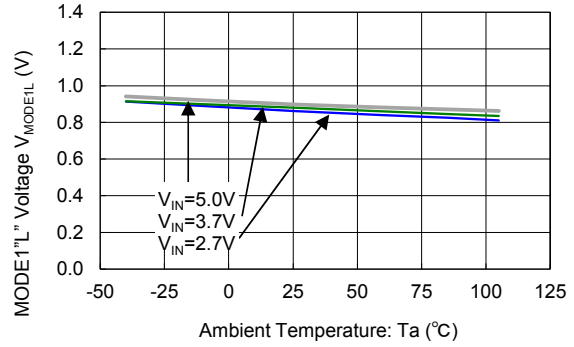

(17) MDOE2"H" Voltage vs. Ambient Temperature

XC9273B06D

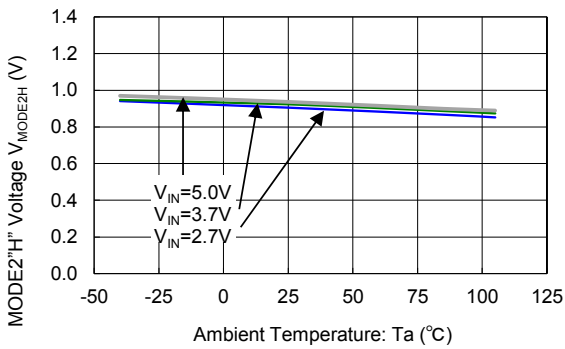

(18) MODE2"L" Voltage vs. Ambient Temperature

XC9273B06D

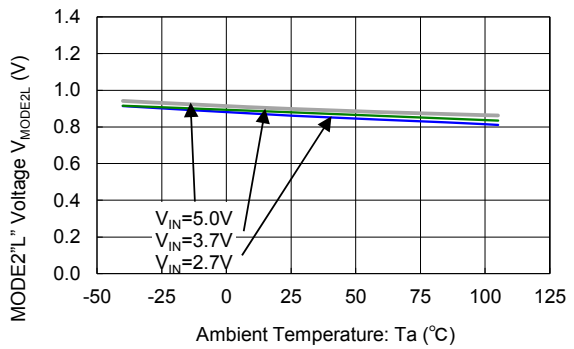

(19) MDOE3"H" Voltage vs. Ambient Temperature

XC9273B06D

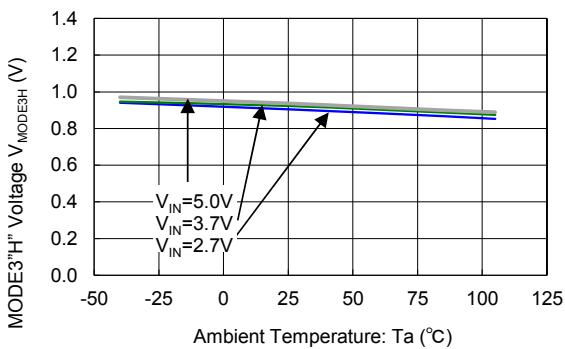

(20) MODE3"L" Voltage vs. Ambient Temperature

XC9273B06D

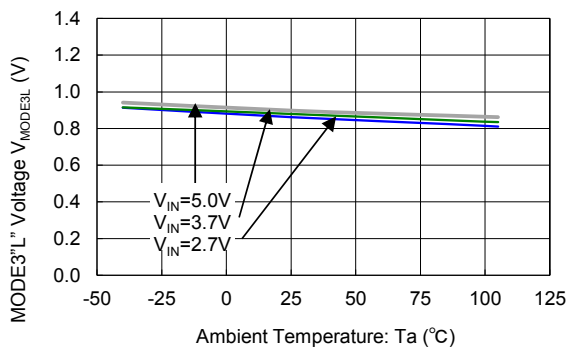

TYPICAL PERFORMANCE CHARACTERISTICS(Continued)

(21) Current Limit vs. Ambient Temperature

XC9273B06D

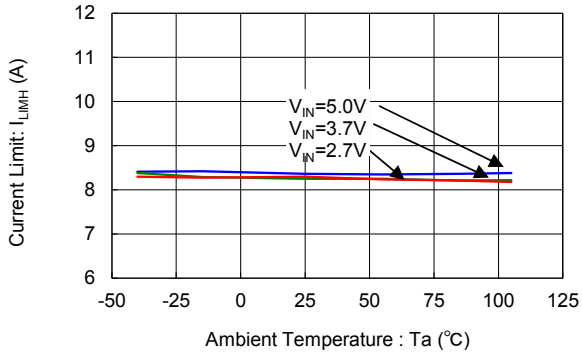

(22) Soft-Start Time vs. Ambient Temperature

XC9273B06D

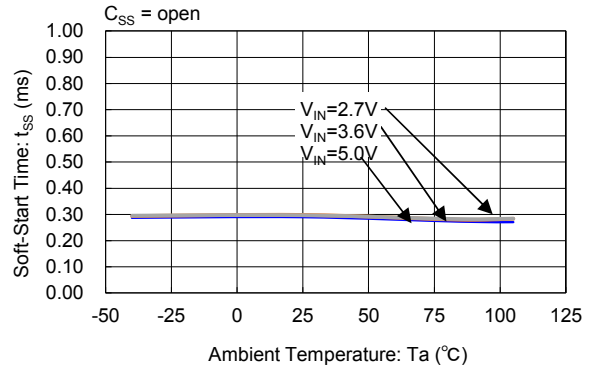

(23) Soft - off Time vs. Ambient Temperature

XC9273B06D

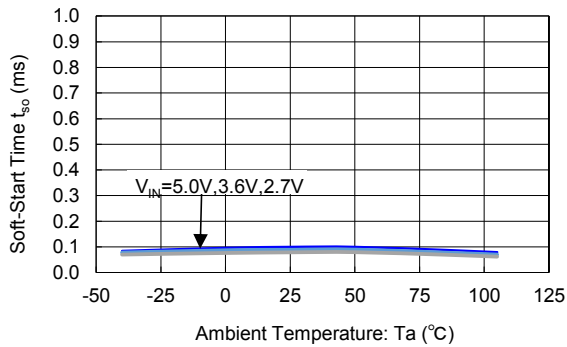

(24) CL Discharge Resistance vs. Ambient Temperature

XC9273B06D

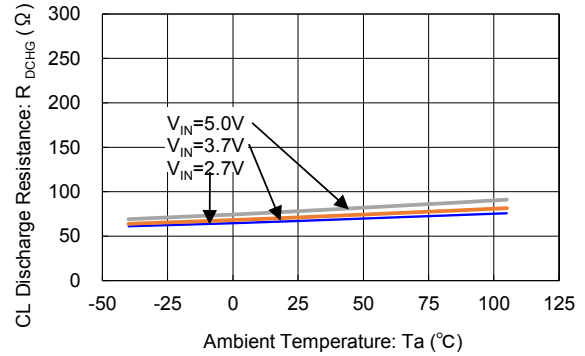

(25) PG detect voltage vs. Ambient Temperature

XC9273B06D

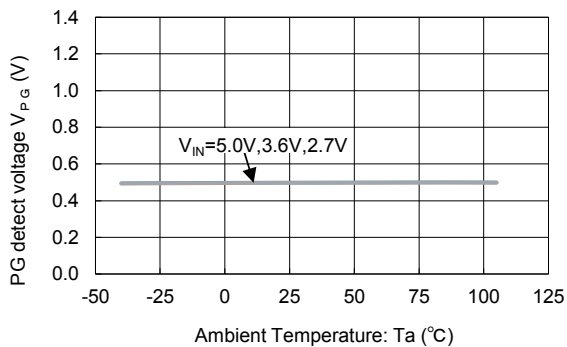

(26) Short Protection Threshold vs. Ambient Temperature

XC9273B06D

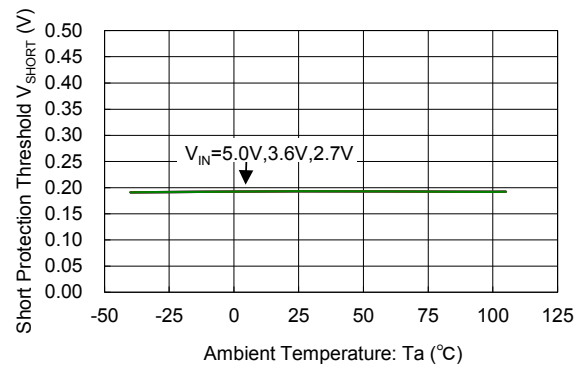

■ TYPICAL PERFORMANCE CHARACTERISTICS(Continued)

(27) Load Transient Response

XC9273B06D

$V_{IN} = 5.0V$ $V_{OUT} = 1.2V$ $f_{OSC} = 3.0MHz$ $I_{OUT} = 0.1A \Rightarrow 3.0A$
 $L = MWSA0624 (0.22\mu H)$, $C_{IN} = 47\mu F (GRM31CR61A476ME15L)$
 $C_L = 47\mu F (GRM31CR60J476ME19L)$
 $RFB1=91k\Omega$, $RFB2=91k\Omega$, $CFB=560pF$ MODE1=H (PWM)

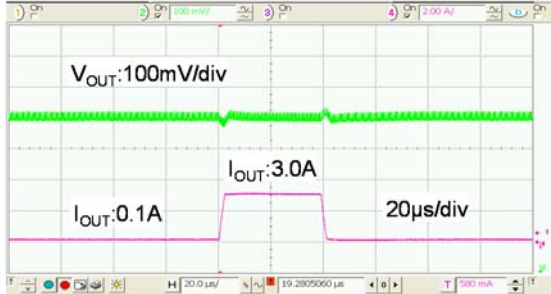

XC9273B06D

$V_{IN} = 5.0V$ $V_{OUT} = 1.2V$ $f_{OSC} = 3.0MHz$ $I_{OUT} = 0.1A \Rightarrow 3.0A$
 $L = MWSA0624 (0.22\mu H)$, $C_{IN} = 47\mu F (GRM31CR61A476ME15L)$
 $C_L = 47\mu F (GRM31CR60J476ME19L)$
 $RFB1=91k\Omega$, $RFB2=91k\Omega$, $CFB=560pF$ MODE1=L (PFM/PWM)

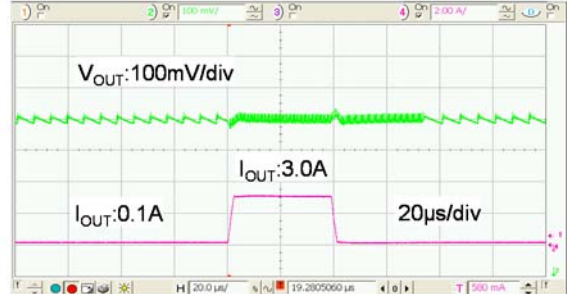

XC9273B06D

$V_{IN} = 5.0V$ $V_{OUT} = 1.8V$ $f_{OSC} = 3.0MHz$ $I_{OUT} = 0.1A \Rightarrow 3.0A$
 $L = MWSA0624 (0.22\mu H)$, $C_{IN} = 47\mu F (GRM31CR61A476ME15L)$
 $C_L = 47\mu F (GRM31CR60J476ME19L)$
 $RFB1=36k\Omega$, $RFB2=18k\Omega$, $CFB=1500pF$ MODE1=H (PWM)

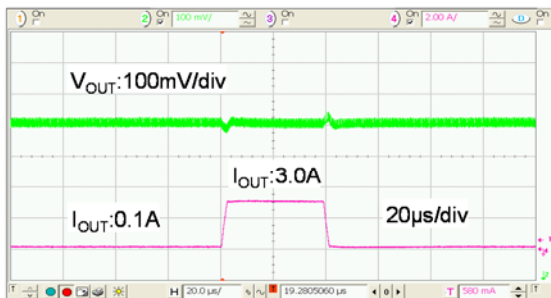

XC9273B06D

$V_{IN} = 5.0V$ $V_{OUT} = 1.8V$ $f_{OSC} = 3.0MHz$ $I_{OUT} = 0.1A \Rightarrow 3.0A$
 $L = MWSA0624 (0.22\mu H)$, $C_{IN} = 47\mu F (GRM31CR61A476ME15L)$
 $C_L = 47\mu F (GRM31CR60J476ME19L)$
 $RFB1=36k\Omega$, $RFB2=18k\Omega$, $CFB=1500pF$ MODE1=L (PFM/PWM)



XC9273B06D

$V_{IN} = 5.0V$ $V_{OUT} = 3.3V$ $f_{OSC} = 3.0MHz$ $I_{OUT} = 0.1A \Rightarrow 3.0A$
 $L = MWSA0624 (0.22\mu H)$, $C_{IN} = 47\mu F (GRM31CR61A476ME15L)$
 $C_L = 94\mu F (GRM31CR60J476ME19Lx2)$
 $RFB1=68k\Omega$, $RFB2=15k\Omega$, $CFB=820pF$ MODE1=H (PWM)

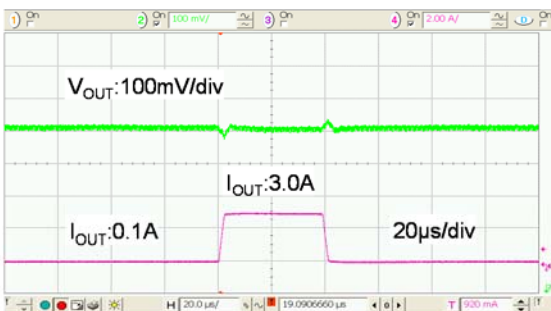

XC9273B06D

$V_{IN} = 5.0V$ $V_{OUT} = 3.3V$ $f_{OSC} = 3.0MHz$ $I_{OUT} = 0.1A \Rightarrow 3.0A$
 $L = MWSA0624 (0.22\mu H)$, $C_{IN} = 47\mu F (GRM31CR61A476ME15L)$
 $C_L = 94\mu F (GRM31CR60J476ME19Lx2)$
 $RFB1=68k\Omega$, $RFB2=15k\Omega$, $CFB=820pF$ MODE1=L (PFM/PWM)

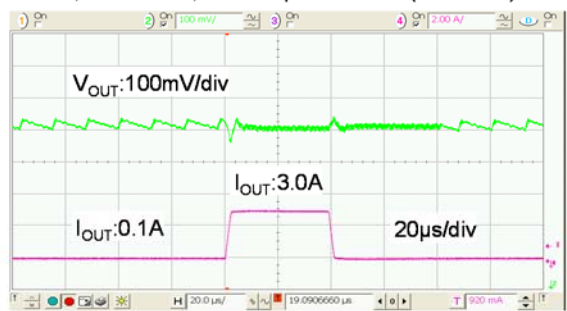

TYPICAL PERFORMANCE CHARACTERISTICS(Continued)

(27) Load Transient Response (Continued)

XC9273B06C

$V_{IN} = 5.0V$ $V_{OUT} = 1.2V$ $f_{OSC} = 1.2MHz$ $I_{OUT} = 0.1A \Rightarrow 3.0A$
 $L = MVSA0603 (0.56\mu H)$, $C_{IN} = 47\mu F(GRM31CR61A476ME15L)$
 $C_L = 47\mu F(GRM31CR60J476ME19L)$
 $RFB1=91k\Omega$, $RFB2=91k\Omega$, $CFB=560pF$ $MODE1=H$ (PVM)

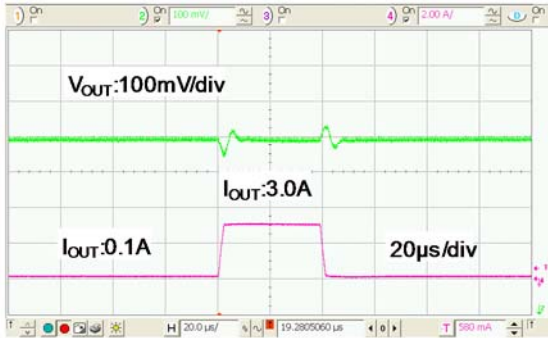

XC9273B06C

$V_{IN} = 5.0V$ $V_{OUT} = 1.2V$ $f_{OSC} = 1.2MHz$ $I_{OUT} = 0.1A \Rightarrow 3.0A$
 $L = MVSA0603 (0.56\mu H)$, $C_{IN} = 47\mu F(GRM31CR61A476ME15L)$
 $C_L = 47\mu F(GRM31CR60J476ME19L)$
 $RFB1=91k\Omega$, $RFB2=91k\Omega$, $CFB=560pF$ $MODE1=L$ (PFM/PVM)

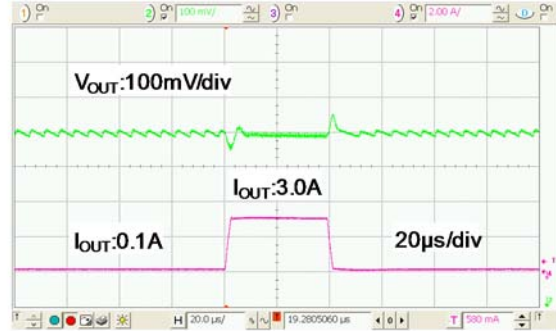

XC9273B06C

$V_{IN} = 5.0V$ $V_{OUT} = 1.8V$ $f_{OSC} = 1.2MHz$ $I_{OUT} = 0.1A \Rightarrow 3.0A$
 $L = MVSA0603 (0.56\mu H)$, $C_{IN} = 47\mu F(GRM31CR61A476ME15L)$
 $C_L = 47\mu F(GRM31CR60J476ME19L)$
 $RFB1=36k\Omega$, $RFB2=18k\Omega$, $CFB=1500pF$ $MODE1=H$ (PVM)



XC9273B06C

$V_{IN} = 5.0V$ $V_{OUT} = 1.8V$ $f_{OSC} = 1.2MHz$ $I_{OUT} = 0.1A \Rightarrow 3.0A$
 $L = MVSA0603 (0.56\mu H)$, $C_{IN} = 47\mu F(GRM31CR61A476ME15L)$
 $C_L = 47\mu F(GRM31CR60J476ME19L)$
 $RFB1=36k\Omega$, $RFB2=18k\Omega$, $CFB=1500pF$ $MODE1=L$ (PFM/PVM)

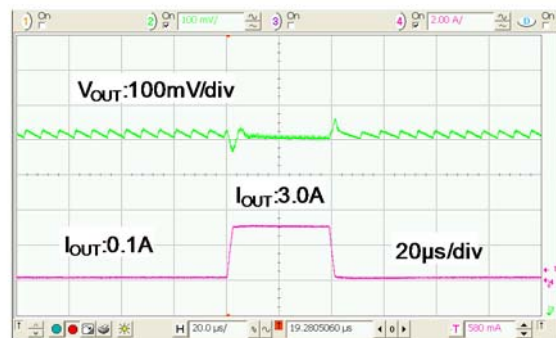

XC9273B06C

$V_{IN} = 5.0V$ $V_{OUT} = 3.3V$ $f_{OSC} = 1.2MHz$ $I_{OUT} = 0.1A \Rightarrow 3.0A$
 $L = MVSA0603 (0.56\mu H)$, $C_{IN} = 47\mu F(GRM31CR61A476ME15L)$
 $C_L = 94\mu F(GRM31CR60J476ME19Lx2)$
 $RFB1=68k\Omega$, $RFB2=15k\Omega$, $CFB=820pF$ $MODE1=H$ (PVM)

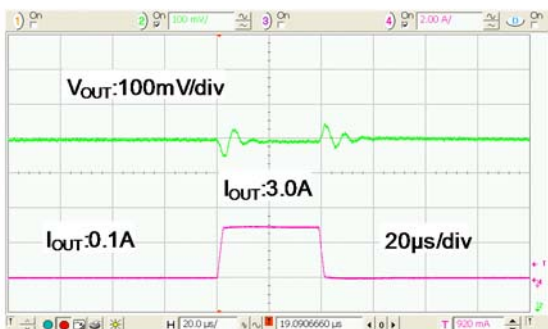

XC9273B06C

$V_{IN} = 5.0V$ $V_{OUT} = 3.3V$ $f_{OSC} = 1.2MHz$ $I_{OUT} = 0.1A \Rightarrow 3.0A$
 $L = MVSA0603 (0.56\mu H)$, $C_{IN} = 47\mu F(GRM31CR61A476ME15L)$
 $C_L = 94\mu F(GRM31CR60J476ME19Lx2)$
 $RFB1=68k\Omega$, $RFB2=15k\Omega$, $CFB=820pF$ $MODE1=L$ (PFM/PVM)



PACKAGING INFORMATION

●QFN0404-24C (unit: mm)

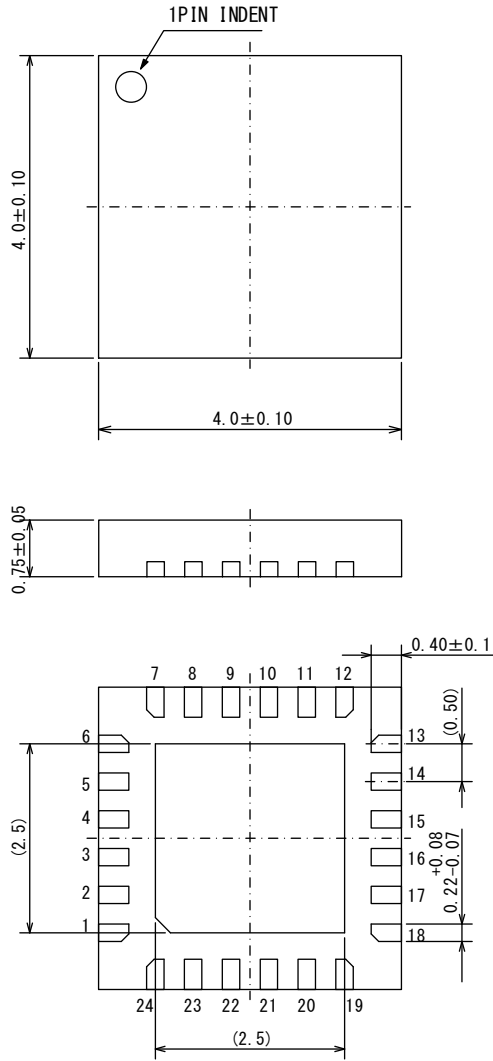

●QFN0404-24C Reference Pattern Layout (unit: mm)

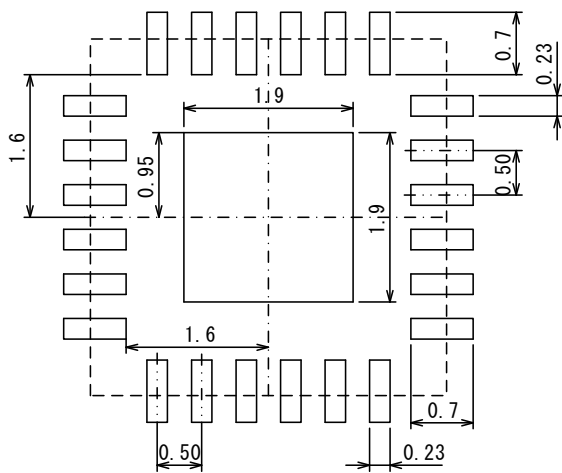

QFN0404-24C Power Dissipation (105°C)

Power dissipation data for the QFN0404-24C is shown in this page.
 The value of power dissipation varies with the mount board conditions.
 Please use this data as the reference data taken in the following condition.

1. Measurement Condition

Condition: Mount on a board
 Ambient: Natural convection
 Soldering: Lead (Pb) free
 Board Dimensions: 40 x 40 mm (1600mm²)
 Board Structure: 4 Copper Layers
 Each layer is 50% connected to the package heat-sink.
 Material: Glass Epoxy (FR-4)
 Thickness: 1.0 mm
 Through-hole: 4 x 0.4 Diameter

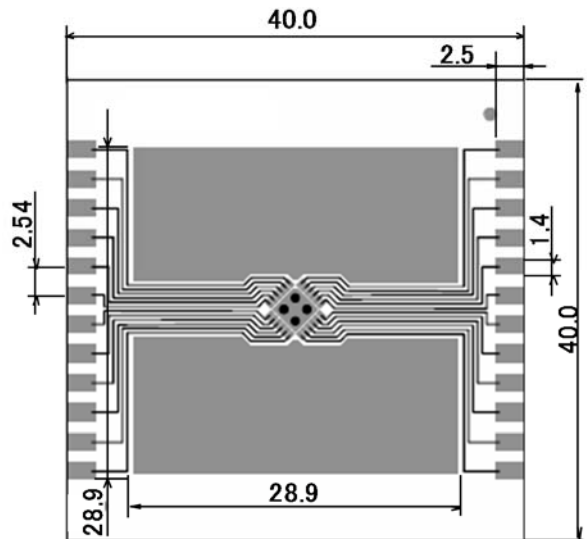

Evaluation Board (Unit: mm)

2. Power Dissipation vs. Ambient Temperature

| Ambient Temperature (°C) | Power Dissipation Pd (mW) | Thermal Resistance(°C/W) |
|--------------------------|---------------------------|--------------------------|
| 25 | 1500 | 66.67 |
| 85 | 600 | |

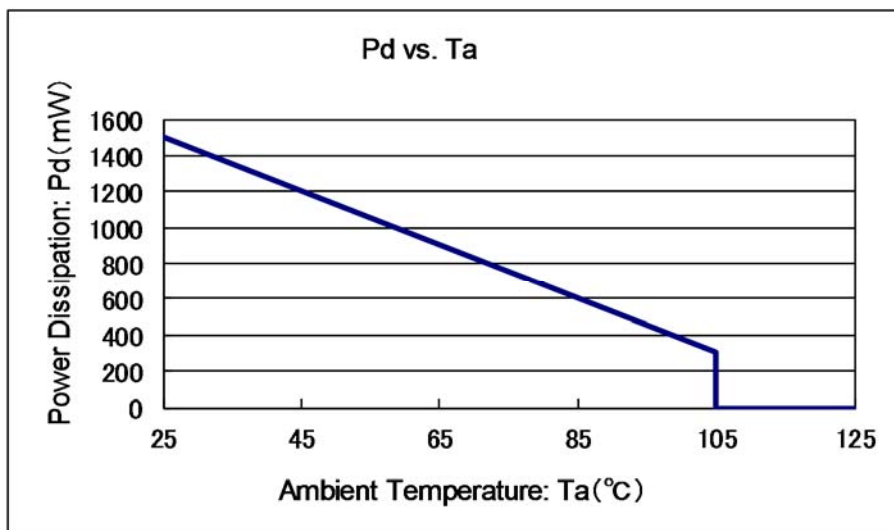

MARKING RULE

① represents product series

| MARK | PRODUCT SERIES |
|------|----------------|
| 7 | XC9273****-G |

② represents Type and Adjustable Output Voltage

| MARK | PRODUCT SERIES |
|------|----------------|
| B | XC9273B06***-G |

③ represents Oscillation Frequency

| MARK | FREQUENCY | PRODUCT SERIES |
|------|-----------|----------------|
| C | 1.2MHz | XC9273***C**-G |
| D | 3.0MHz | XC9273***D**-G |

④,⑤ represents production lot number

01~09、0A~0Z、11~9Z、A1~A9、AA~AZ、B1~ZZ in order.

(G, I, J, O, Q, W excluded)

* No character inversion used.

QFN0404-24C

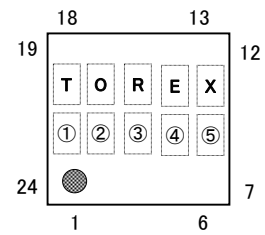

("TOREX" in the figure is fixed)

1. The product and product specifications contained herein are subject to change without notice to improve performance characteristics. Consult us, or our representatives before use, to confirm that the information in this datasheet is up to date.
2. The information in this datasheet is intended to illustrate the operation and characteristics of our products. We neither make warranties or representations with respect to the accuracy or completeness of the information contained in this datasheet nor grant any license to any intellectual property rights of ours or any third party concerning with the information in this datasheet.
3. Applicable export control laws and regulations should be complied and the procedures required by such laws and regulations should also be followed, when the product or any information contained in this datasheet is exported.
4. The product is neither intended nor warranted for use in equipment of systems which require extremely high levels of quality and/or reliability and/or a malfunction or failure which may cause loss of human life, bodily injury, serious property damage including but not limited to devices or equipment used in 1) nuclear facilities, 2) aerospace industry, 3) medical facilities, 4) automobile industry and other transportation industry and 5) safety devices and safety equipment to control combustions and explosions. Do not use the product for the above use unless agreed by us in writing in advance.
5. Although we make continuous efforts to improve the quality and reliability of our products; nevertheless Semiconductors are likely to fail with a certain probability. So in order to prevent personal injury and/or property damage resulting from such failure, customers are required to incorporate adequate safety measures in their designs, such as system fail safes, redundancy and fire prevention features.
6. Our products are not designed to be Radiation-resistant.
7. Please use the product listed in this datasheet within the specified ranges.
8. We assume no responsibility for damage or loss due to abnormal use.
9. All rights reserved. No part of this datasheet may be copied or reproduced unless agreed by Torex Semiconductor Ltd in writing in advance.

TOREX SEMICONDUCTOR LTD.

单击下面可查看定价，库存，交付和生命周期等信息

[>>Torex Semiconductor\(特瑞仕\)](#)