

XC6237 Series

Ultra-Low Supply Current 0.6 μ A High Speed LDO Voltage Regulators

ETR03100-001

☆GreenOperation Compatible

■ GENERAL DESCRIPTION

The XC6237 series is a CMOS process high-speed LDO regulator IC that achieves low current consumption, high accuracy, and high ripple rejection.

The output voltage is fixed internally and can be set in the range of 1.2V to 5.0V (0.05V step).

It has a Green Operation (GO) function that achieves both high-speed operation and low current consumption, and switches automatically between high speed (HS) mode and power save (PS) mode according to the output current.

At light load, high efficiency is realized by operating in PS mode with low current consumption, and at heavy load, high speed operation is enabled by operating in HS mode. This is ideal for applications that require both low current consumption and high speed operation.

The lineup of small and thin USPQ-4B05 and general-purpose SSOT-24 and SOT-23 is available for various applications. Low ESR capacitors such as ceramic capacitors can be used at the output of LDO.

■ APPLICATIONS

- Smart meters
- Smart cards
- Wearable devices
- Remote controllers

■ FEATURES

Low Supply Current	: 0.6 μ A TYP (PS)
Accuracy	: $\pm 1.0\%$ ($V_{OUT} \geq 2.00V$) $\pm 20mV$ ($V_{OUT} \leq 1.95V$)
Operating Voltage Range	: 1.6V ~ 6.0V
Output Voltage Range	: 1.2V ~ 5.0V(0.05V steps)
Maximum Output Current	: 150mA
High Ripple Rejection	: 60dB@1kHz (HS)
Function	: Green Operation, CE function : "H" active C _L Discharge (A TYPE)
Protective Function	: Current Limit 250mA(TYP) Short-Circuit Current 25mA(TYP)
Output Capacitor	: Ceramic capacitor
Operating Ambient Temperature	: -40°C ~ +105°C
Packages	: USPQ-4B05 (1.0x1.0xh0.33mm) SSOT-24 SOT-23(No CE function) (In Development)
Environmentally Friendly	: EU RoHS Compliant, Pb Free

■ TYPICAL APPLICATION CIRCUIT

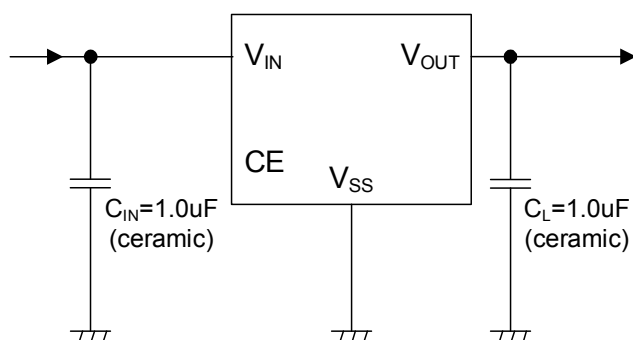

■ TYPICAL PERFORMANCE CHARACTERISTICS

XC6237x181

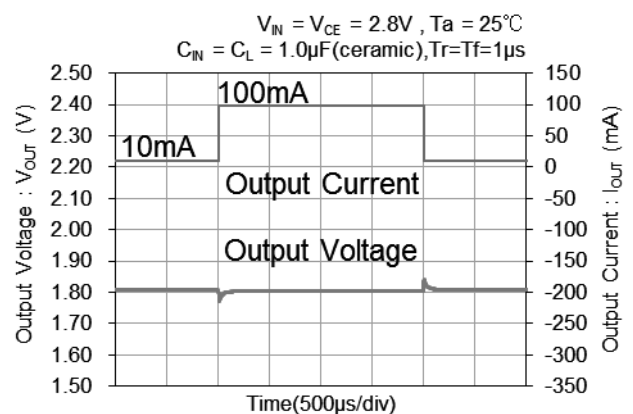

■ BLOCK DIAGRAMS

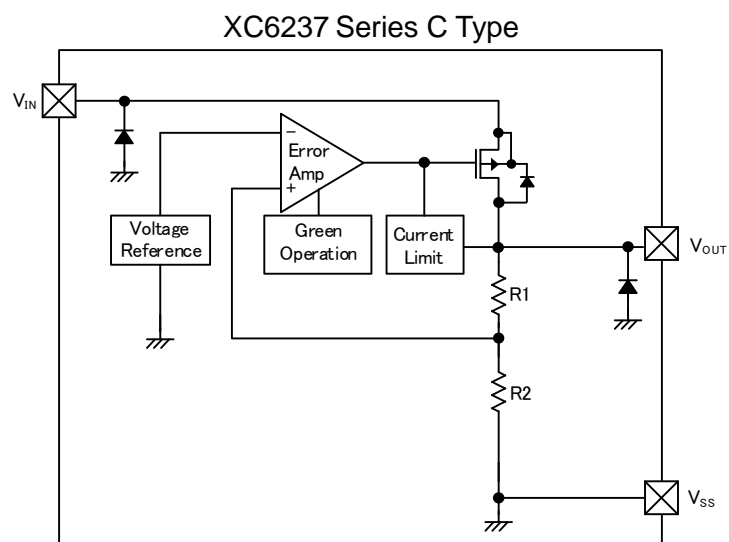
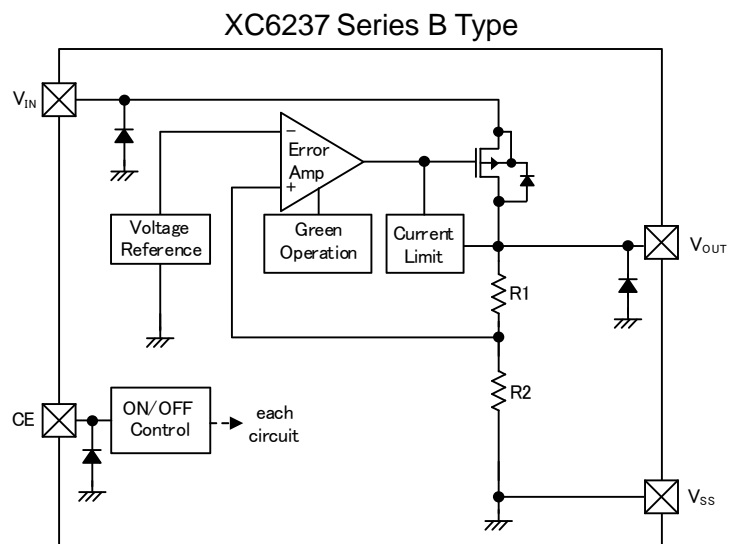
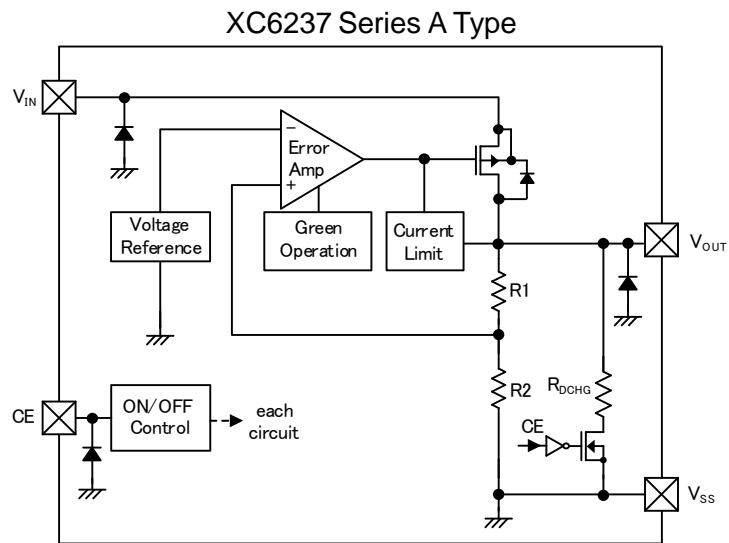

※Diodes inside the circuits are ESD protection diodes and parasitic diodes.

■ PRODUCT CLASSIFICATION

● Ordering Information

XC6237①②③④⑤⑥-⑦^(*)

DESIGNATOR	ITEM	SYMBOL	DESCRIPTION
①	TYPE	A	Refer to Selection Guide
		B	
		C	
②③	Output Voltage	12~50	e.g. 2.8V ②=2, ③=8
④	Output Voltage (the 2 nd decimal place)	1	Output Voltage {x.x0V} e.g. 2.80V → ②=2, ③=8, ④=1
		B	Output Voltage {x.x5V} e.g. 2.85V → ②=2, ③=8, ④=B
⑤⑥-⑦	Packages Taping Type	9R-G ^(*)	USPQ-4B05 (A/B TYPE) (5,000pcs/Reel)
		NR-G ^(*)	SSOT-24 (A/B TYPE) (3,000pcs/Reel)
		MR-G ^(*)	SOT-23 (C TYPE) (3,000 pcs/Reel) (In Development)

^(*) "-G" suffix denotes Halogen and Antimony free as well as being fully EU RoHS compliant.

● Selection Guide

TYPE	CE function	CL Auto-Discharge
A	Yes	Yes
B	Yes	-
C	-	-

PIN CONFIGURATION

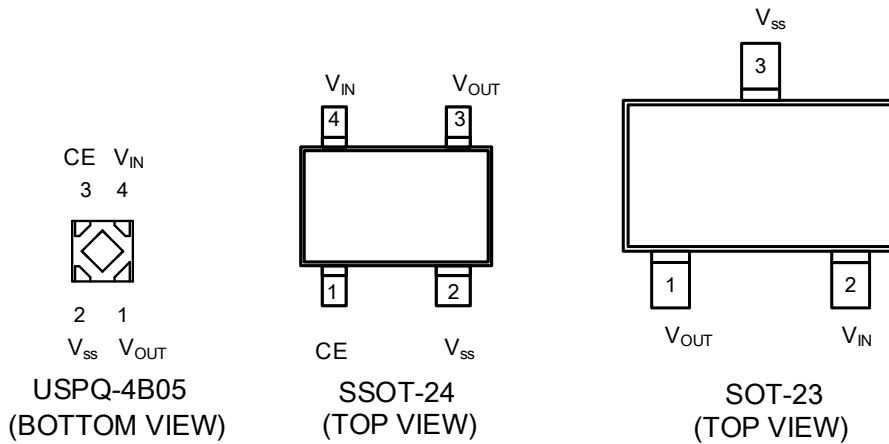

*The dissipation pad for the USPQ-4B05 package should be solder-plated in reference mount pattern and metal masking so as to enhance mounting strength and heat release. If the pad needs to be connected to other pins, it should be connected to V_{SS} (No. 2) pin.

PIN ASSIGNMENT

PIN NUMBER			PIN NAME	FUNCTION
USPQ-4B05	SSOT-24	SOT-23		
1	3	1	V _{OUT}	Output
2	2	3	V _{SS}	Ground
3	1	-	CE	ON/OFF Control
4	4	2	V _{IN}	Power Input

FUNCTION CHART

XC6237series, Type A/B.

PIN NAME	SIGNAL	STATUS
CE	H	Active
	L	Stand-by
	OPEN	Undefined state*

(*1) Please do not leave the CE pin open. Each should have a certain voltage.

■ ABSOLUTE MAXIMUM RATINGS

Ta=25°C

PARAMETER		SYMBOL	RATINGS	UNITS
V _{IN} Pin Voltage		V _{IN}	-0.3~+6.5	V
V _{OUT} Pin Current		I _{OUT}	250 ^{(*)1}	mA
V _{OUT} Pin Voltage		V _{OUT}	-0.3~V _{IN} +0.3 or 6.5 ^{(*)2}	V
CE Pin Voltage		V _{CE}	-0.3~+6.5	V
Power Dissipation	USPQ-4B05	Pd	100	mW
			550 (40mm x 40mm Standard Board) ^{(*)3}	
	SSOT-24		150	
			500 (40mm x 40mm Standard Board) ^{(*)3}	
	SOT-23		680 (JESD51-7 Board) ^{(*)3}	
			250	
Operating Ambient Temperature		Topr	-40~+105	°C
Storage Temperature		Tstg	-55~+125	°C

All voltages are described based on the V_{SS}.

^{(*)1} Please use within the range of $I_{OUT} \leq Pd / (V_{IN} - V_{OUT})$

^{(*)2} The maximum rating corresponds to the lowest value between V_{IN}+0.3V or +6.5V.

^{(*)3} The power dissipation figure shown is PCB mounted and is for reference only.

The mounting condition is please refer to PACKAGING INFORMATION.

ELECTRICAL CHARACTERISTICS

Ta=25°C

PARAMETER	SYMBOL	CONDITIONS	MIN	TYP	MAX	UNIT	CIRCUIT
Input Voltage	V _{IN}		1.6	-	6.0	V	①
Output Voltage	V _{OUT(E)} ^(*)	V _{OUT(T)} ≥ 2.00V I _{OUT} = 10mA	V _{OUT(T)} ^(*) × 0.99	V _{OUT(T)} ^(*)	V _{OUT(T)} ^(*) × 1.01	V	①
		V _{OUT(T)} ≤ 1.95V I _{OUT} = 10mA	V _{OUT(T)} ^(*) -0.02		V _{OUT(T)} ^(*) + 0.02		
Maximum Output Current	I _{OUTMAX}		150	-	-	mA	①
Load Regulation	ΔV _{OUT}	10mA ≤ I _{OUT} ≤ 150mA	-	-	20	mV	①
		0.1mA ≤ I _{OUT} ≤ 150mA	-	10	50		
Dropout Voltage	V _{dif} ^(*)	I _{OUT} = 150mA	-	[E-1] ^(*)		mV	①
Supply Current	I _{SS}	I _{OUT} = 0mA	-	0.6	0.9	μA	②
Stand-by Current	I _{STB}	V _{IN} = 6.0V, V _{CE} = V _{SS}	-	0.01	0.1	μA	②
Line Regulation	ΔV _{OUT} / (ΔV _{IN} · V _{OUT})	V _{OUT(T)} + 0.5V ≤ V _{IN} ≤ 6.0V I _{OUT} = 30mA	-	±0.05	±0.2	%/V	①
Output Voltage Temperature Characteristics	ΔV _{OUT} / (ΔT _{opr} · V _{OUT})	I _{OUT} = 10mA -40°C ≤ T _{opr} ≤ 105°C	-	±50	-	ppm/°C	①
Ripple Rejection	PSRR	V _{IN} = 5.75V _{DC} + 0.5V _{p-pAC} 4.75V ≤ V _{OUT(T)} V _{CE} = V _{IN} , I _{OUT} = 30mA, f = 1kHz	-	60	-	dB	④
		V _{IN} = {V _{OUT(T)} + 1.0} V _{DC} + 0.5V _{p-pAC} V _{OUT(T)} ≤ 4.7V V _{CE} = V _{IN} , I _{OUT} = 30mA, f = 1kHz					
Current Limit	I _{LIM}	V _{OUT} = V _{OUT(E)} × 0.95	155	250	-	mA	①
Short-Circuit Current	I _{SHORT}	V _{OUT} = V _{SS}	-	25	-	mA	①
PS Switched Current	I _{GOR}	I _{OUT} : heavy to light load	0.5	-	-	mA	②
HS Switched Current	I _{GO}	I _{OUT} : light to heavy load	-	-	10	mA	②
CE "H" Level Voltage	V _{CEH}		1.2	-	6.0	V	③
CE "L" Level Voltage	V _{CEL}		V _{SS}	-	0.3	V	③
CE "H" Level Current	I _{CEH}		-0.1	-	0.1	μA	③
CE "L" Level Current	I _{CEL}	V _{CE} = V _{SS}	-0.1	-	0.1	μA	③
CL Auto-Discharge Resistance	R _{DCHG}	V _{IN} = V _{OUT} = 6.0V, V _{CE} = V _{SS}	-	280	-	Ω	①

Unless otherwise stated regarding input voltage conditions,

(V_{IN} = V_{OUT(T)} + 1.0V), V_{CE} = V_{IN} (A/B TYPE only), C_{IN} = 1.0μF, C_L = 1.0μF.

(*) V_{OUT(E)} : Effective output voltage

(*) V_{OUT(T)} : Nominal output voltage.

(*) V_{dif} = {V_{IN1} - V_{OUT1}}

V_{IN1} : The input voltage when V_{OUT1} appears as input voltage is gradually decreased.

V_{OUT1} : A voltage equal to 98% of the output voltage whenever an amply stabilized I_{OUT} {V_{OUT(T)} + 1.0V} is input.

(*) E-1 : DROPOUT VOLTAGE (Refer to the Voltage Chart)

■ ELECTRICAL CHARACTERISTICS

● Voltage Chart

Ta=25°C

SYMBOL	E-1	
	DROPOUT VOLTAGE Vdif (mV) I _{OUT} =150mA	
	V _{OUT(T)}	
	TYP.	MAX
1.20	470	825
1.25		
1.30		
1.35		
1.40		
1.45		
1.50		
1.55		
1.60	315	550
1.65		
1.70		
1.75		
1.80		
1.85		
1.90		
1.95		
2.00	240	420
2.05		
2.10		
2.15		
2.20		
2.25		
2.30		
2.35		
2.40		
2.45		
2.50	200	325
2.55		
2.60		
2.65		
2.70		
2.75		
2.80		
2.85		
2.90		
2.95		
3.00	165	255
3.05		
3.10		
3.15		
3.20		
3.25		
3.30		
3.35		

SYMBOL	E-1	
	DROPOUT VOLTAGE Vdif (mV) I _{OUT} =150mA	
	V _{OUT(T)}	
	TYP.	MAX
3.40	165	255
3.45		
3.50		
3.55		
3.60		
3.65		
3.70		
3.75		
3.80	130	235
3.85		
3.90		
3.95		
4.00		
4.05		
4.10		
4.15		
4.20		
4.25		
4.30		
4.35		
4.40		
4.45		
4.50		
4.55		
4.60		
4.65		
4.70		
4.75		
4.80		
4.85		
4.90		
4.95		
5.00		

TEST CIRCUITS

TEST CIRCUITS①

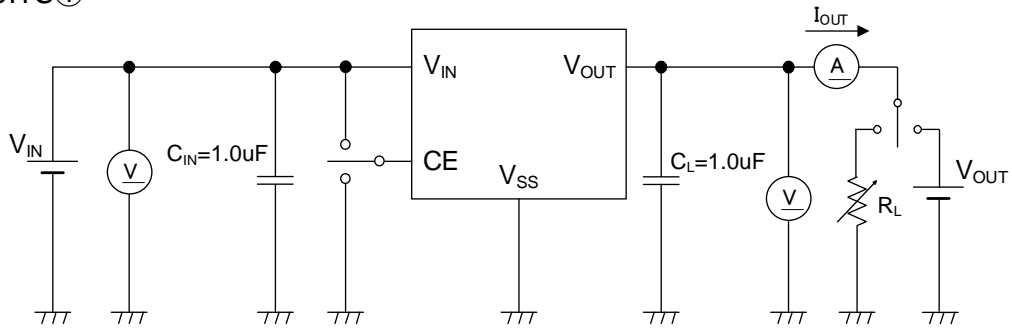

TEST CIRCUITS②

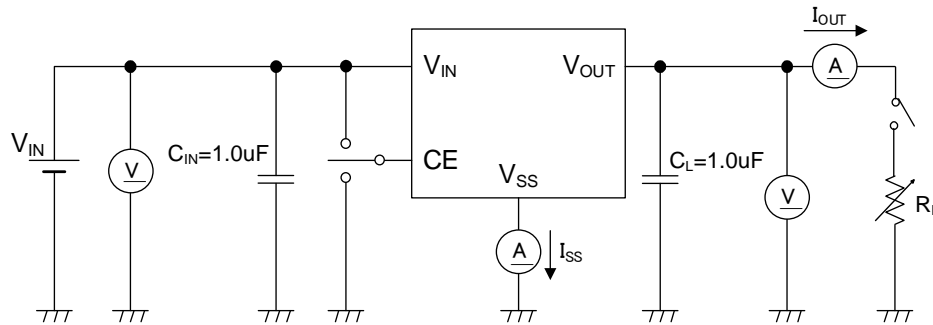

TEST CIRCUITS③

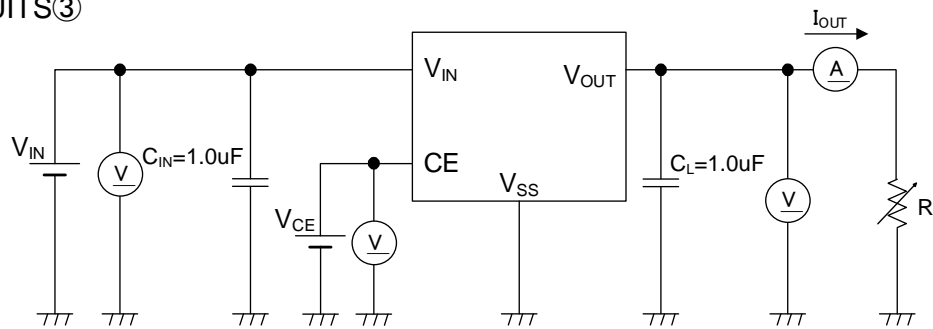

TEST CIRCUITS④

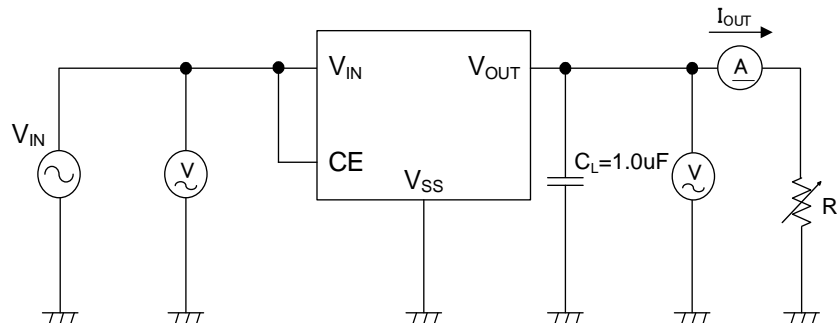

■ TYPICAL APPLICATION CIRCUIT

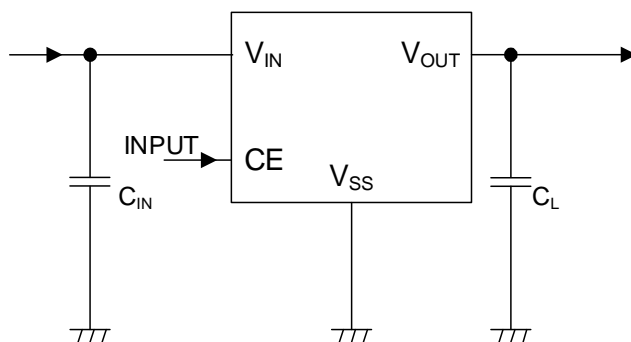

【Typical Examples】^(*)

	MANUFACTURER	PRODUCT NUMBER	VALUE	SIZE(L×W×T)
C _{IN} , C _L	Murata	GRM155C71A105KE11D	1.0uF/10V	1.0×0.5×0.6(mm)
	Murata	GRM033D70J105ME01D	1.0uF/6.3V 2parallel	0.6×0.3×0.39(mm)
	Murata	GRM033R60J225ME47D	2.2uF/6.3V	0.6×0.3×0.39(mm)

^(*) Select components appropriate to the usage conditions (ambient temperature, input & output voltage).

OPERATIONAL EXPLANATION

<Output Voltage Control>

The voltage divided by resistors R1 & R2 is compared with the internal voltage reference by the error amplifier. The P-channel MOSFET, which is connected to the V_{OUT} pin, is then driven by the subsequent output signal. The output voltage at the V_{OUT} pin is controlled and stabilized by a system of negative feedback. The GO function monitors the output current and switches IC's consumption current according to the level of output current.

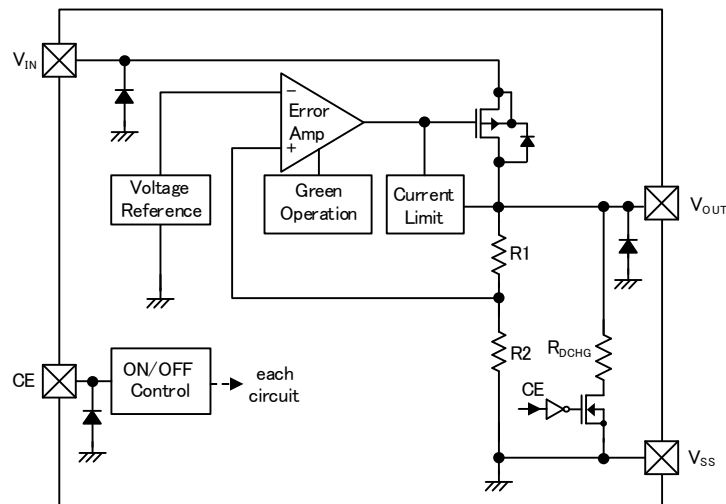

※Diodes inside the circuits are ESD protection diodes and parasitic diodes.

<Green Operation Function >

The GO enables the IC to switch automatically the supply current to the high speed (HS) mode or the power save (PS) mode according to the level of output current. While having both high-speed operation and low supply current state, the series can acquire high efficiency. The switching point of the HS mode and the PS mode is being fixed inside the IC. When the output current becomes I_{GOR} 0.5mA (MIN.) or below, the mode changes automatically to the PS mode and it can reduce supply current in light load.

Also when the output current becomes I_{GO} 10mA (MAX.) or more, the mode changes automatically to the HS mode and the IC becomes high speed operation.

When the input voltage is lower than the nominal output voltage or the input / output voltage difference is small, it may operate in the HS mode regardless of the output current.

<CE Function>

The IC's internal circuitry can be shutdown via the signal from the CE pin with the XC6237 series A/B type. In shutdown mode, output at the V_{OUT} pin will be pulled down to the V_{SS} level via R1 & R2. However the XC6237 series A type has the CL auto-discharge function is able to discharge the electric charge at the CL via the internal auto-discharge resistance, when IC is shutdown mode and power is supplied to the V_{IN} pin, as a result the V_{OUT} pin quickly returns to the V_{SS} level.

The output voltage becomes unstable, when the CE pin is open. Please input a certain voltage within an electrical characteristic into CE pin.

If this IC is used with the correct output voltage for the CE pin, the logic is fixed and the IC will operate normally. However, supply current may increase as a result of through current in the IC's internal circuitry when medium voltage is input.

< Current Limit, Short-Circuit Protection>

The XC6237 series limit output current by current fold-back circuit. When the output current reaches the current limit level (TYP. 250mA), the current fold-back circuit operates and the output current also drops as the output voltage drops. The output voltage drops further and output current decreases. When the output pin is shorted, the output current is I_{SHORT} (TYP> 25mA) and can be used safely by short-circuit.

■ OPERATIONAL EXPLANATION(Continued)

<C_L Auto-Discharge Function>

As for the XC6237 series A type, the C_L auto-discharge function is able to discharge the electric charge at the C_L via the internal auto-discharge resistance, and as a result the V_{OUT} pin quickly returns to the V_{SS} level.

An N-channel transistor connect between the V_{OUT} pin and the V_{SS} pin, and the N-channel quickly discharge the electric charge in C_L when a low signal to the CE pin input.

Discharge time of the C_L and output voltage is determined by a C_L auto-discharge resistor value R_{DCHG} (TYP. 280Ω@Vin=6.0V) and an output capacitor value. Output voltage after starting discharge can be calculated by the following formula.

$$V = V_{OUT(E)} \times e^{-t/\tau}$$

V	: Output voltage after starting discharge
V _{OUT(E)}	: Output voltage
T	: Discharge time
τ	: R _{DCHG} × C _L
C _L	: Capacitance connected V _{OUT} pin
R _{DCHG}	: Output discharge resistor (C _L Discharge Resistance)

It can be expanded on “t”,

$$t = \tau \ln(V_{OUT(E)} / V)$$

Discharge time can be calculated by the above formula.

Time constant τ is defined as (τ = C_L × R_{DCHG}).

it is possible to obtain the discharge time from the above equation.

$$t = \tau \ln(V_{OUT(E)} / V)$$

■ NOTES ON USE

1. For temporary, transitional voltage drop or voltage rising phenomenon, the IC is liable to malfunction should the ratings be exceeded.
2. Where wiring impedance is high, operations may become unstable due to noise and/or phase lag depending on output current. Please strengthen V_{IN} and V_{SS} wiring in particular.
3. The input capacitor (C_{IN}) and the output capacitor (C_L) should be placed to the IC as close as possible and connected 1.0 μF or more capacitor. Since Input capacitor (C_{IN}) and the output capacitor (C_L) have the characteristics are fluctuated by a bias dependence of the capacitor, by the influence of the missing capacity and by temperature characteristics. There is a risk that cannot be stable phase compensation because of them. Please pay attention to the selection of the capacitor to be used.
4. Torex places an importance on improving our products and its reliability. However, by any possibility, we would request user fail-safe design and post-aging treatment on system or equipment.

TYPICAL PERFORMANCE CHARACTERISTICS

(1) Output Voltage vs. Output Current

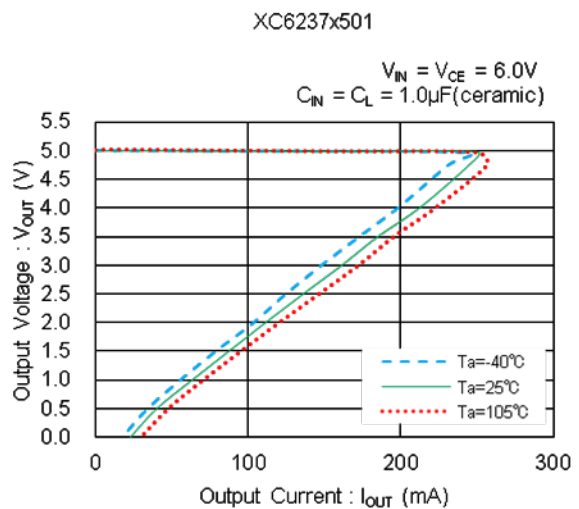
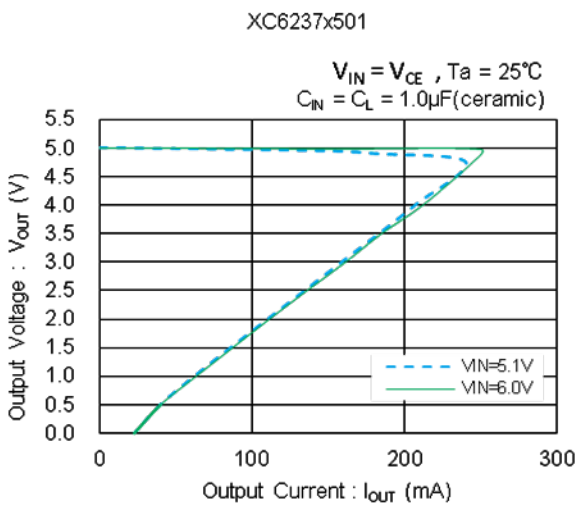
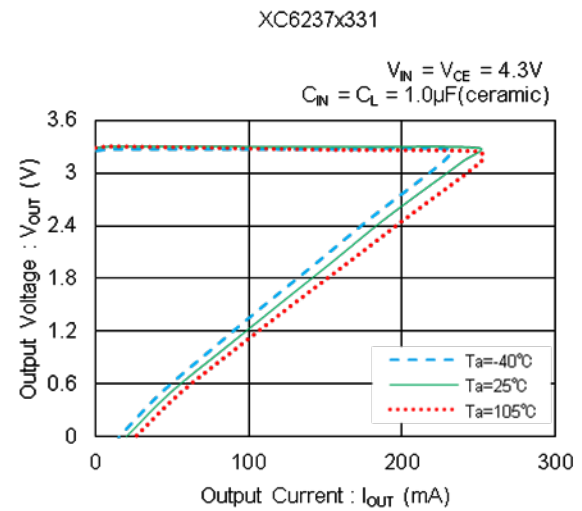
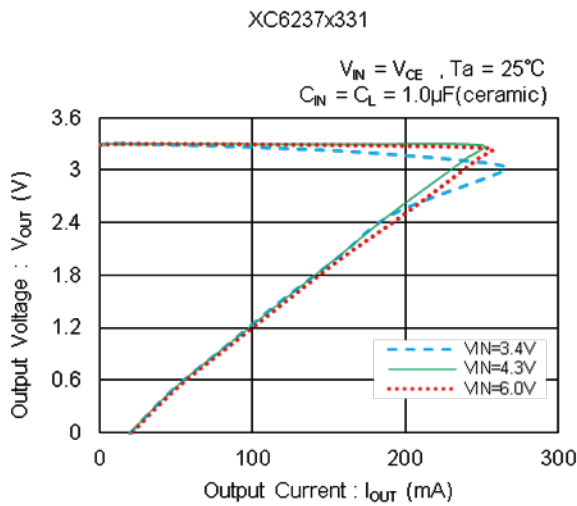
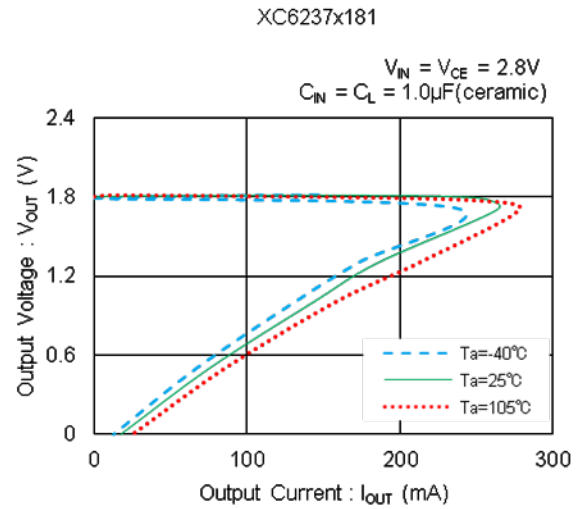
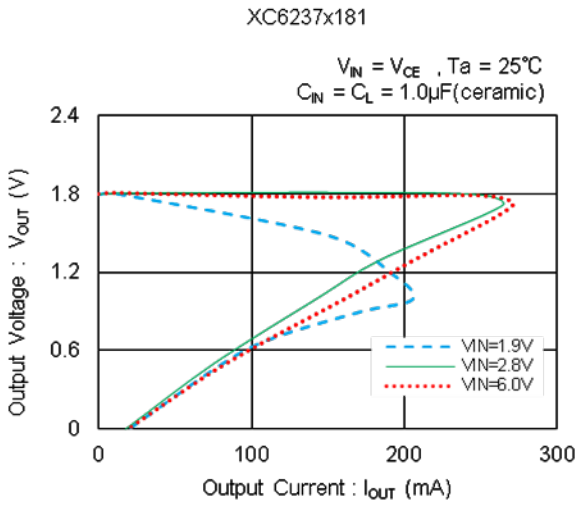

■ TYPICAL PERFORMANCE CHARACTERISTICS (Continued)

(2) Output Voltage vs. Input Voltage

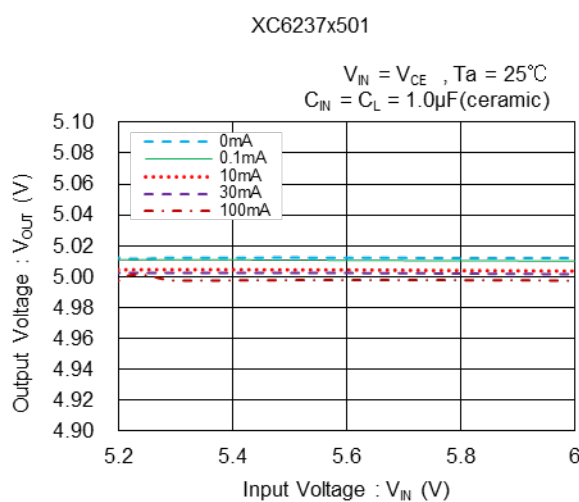
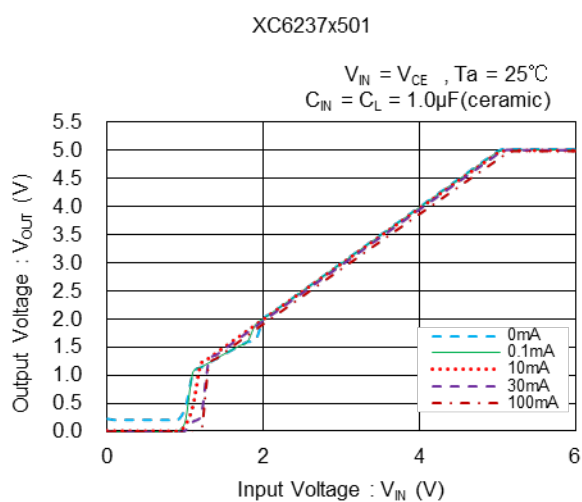
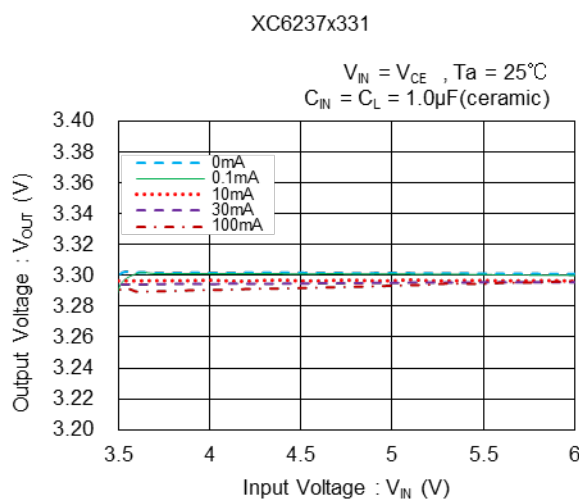
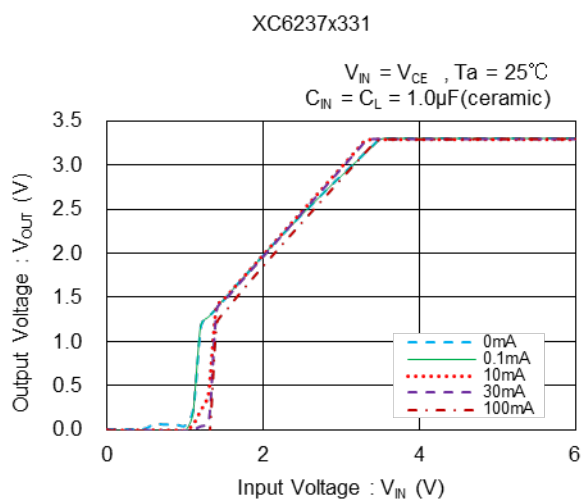
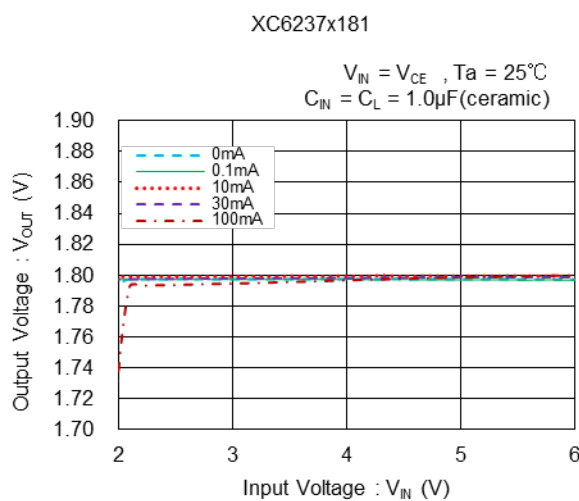
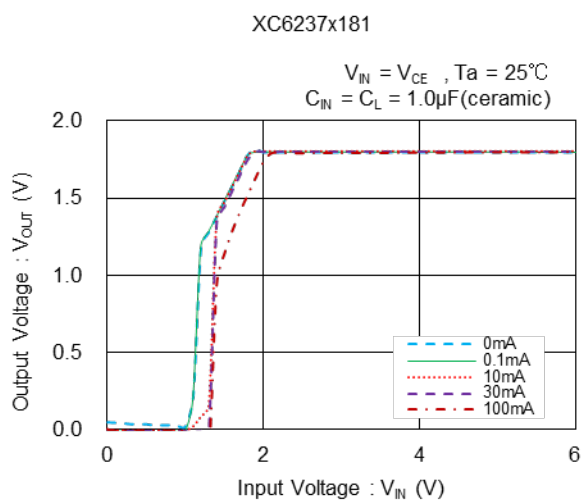

TYPICAL PERFORMANCE CHARACTERISTICS (Continued)

(3) Dropout Voltage vs. Output Current

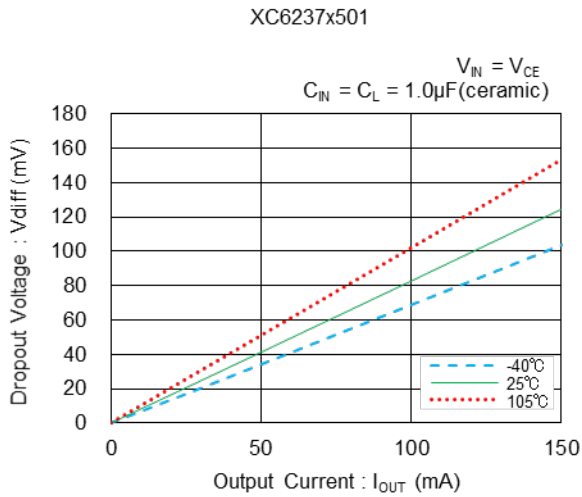
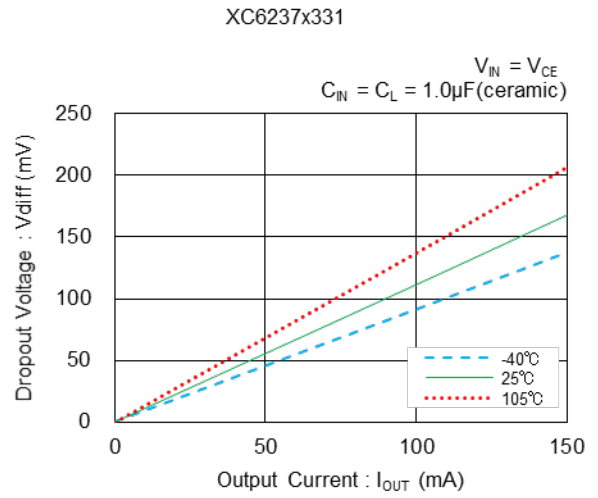
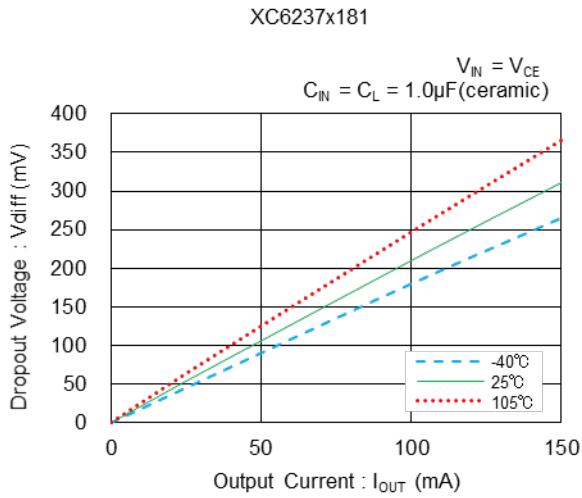

(4) Dropout Voltage vs. Ambient Temperature

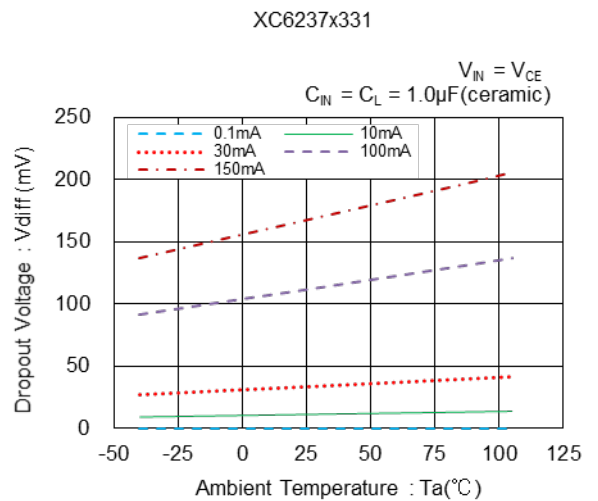
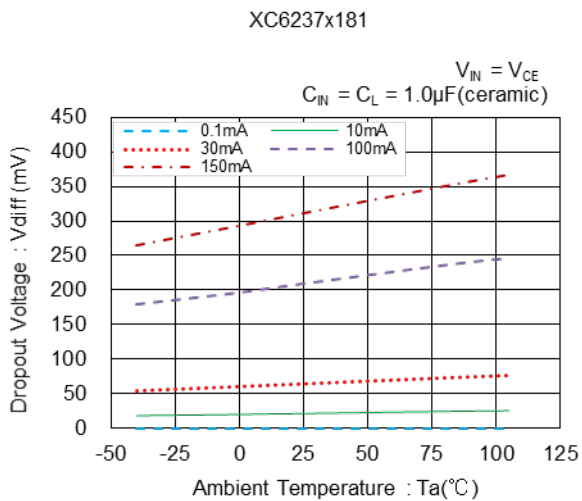

■ TYPICAL PERFORMANCE CHARACTERISTICS (Continued)

(4) Dropout Voltage vs. Ambient Temperature (Continued)

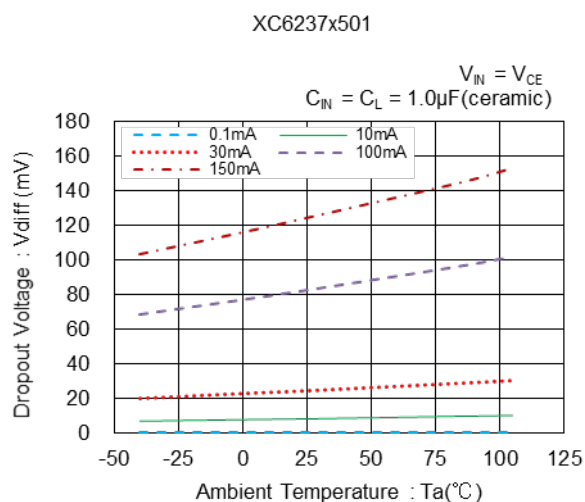

(5) Output Voltage vs. Ambient Temperature

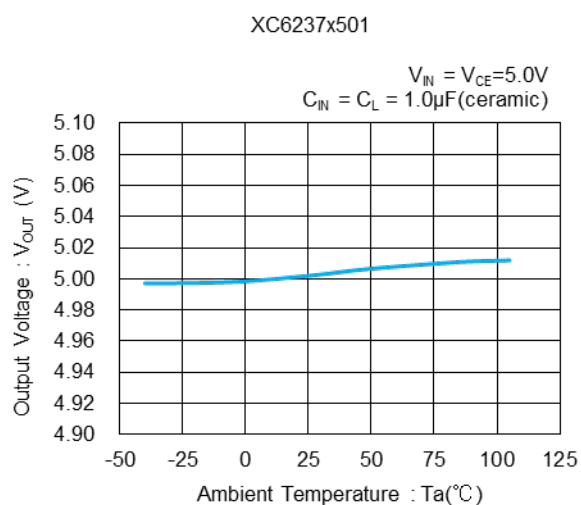
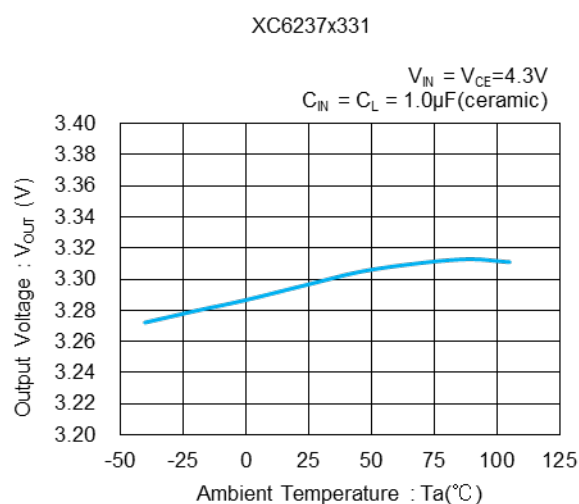
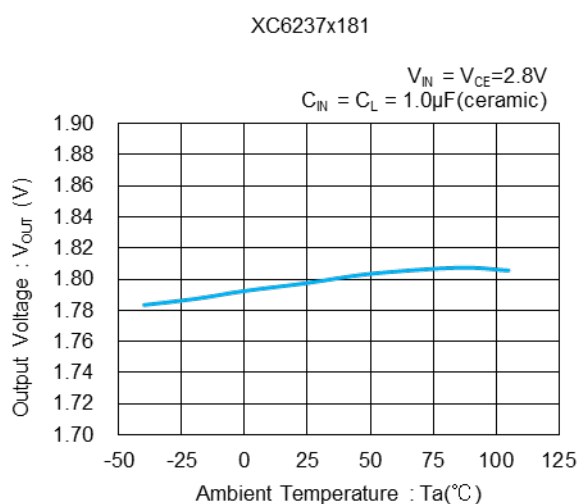

TYPICAL PERFORMANCE CHARACTERISTICS (Continued)

(6) Supply Current vs. Input Voltage

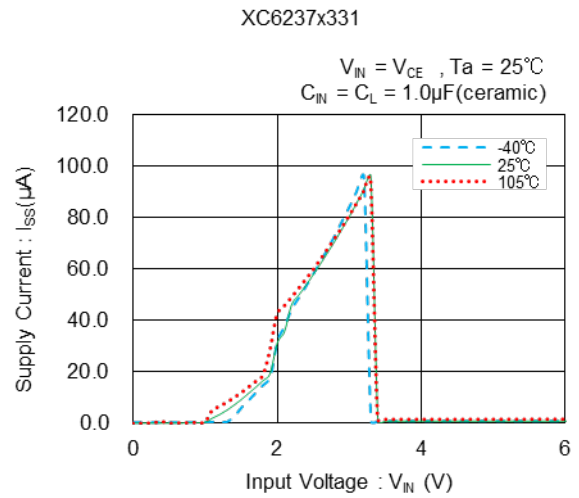
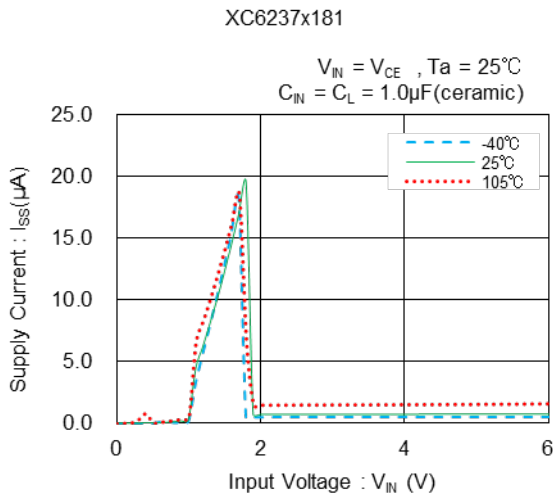

(7) Supply Current vs. Ambient Temperature

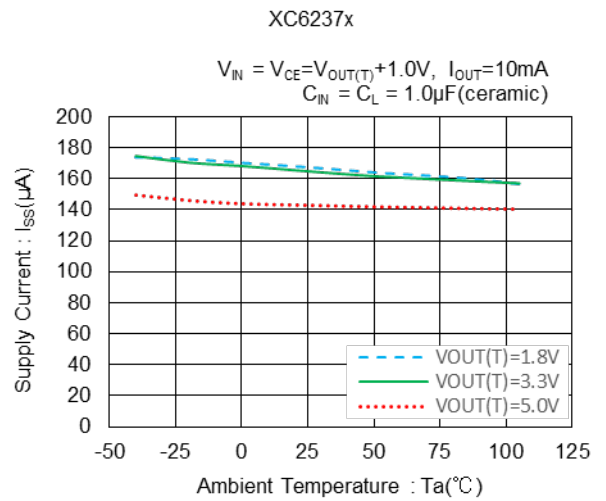
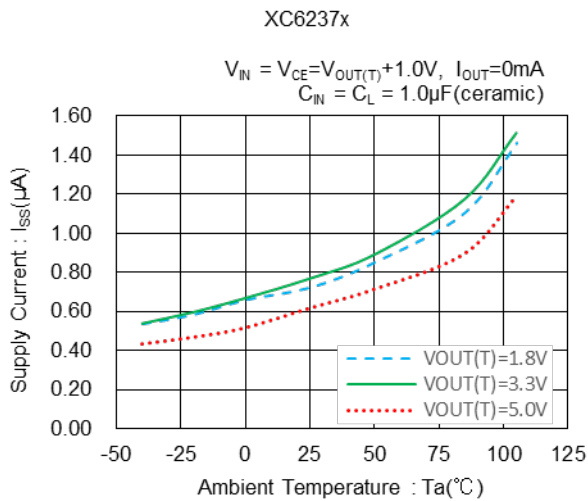

■ TYPICAL PERFORMANCE CHARACTERISTICS (Continued)

(8) Load Transient Response

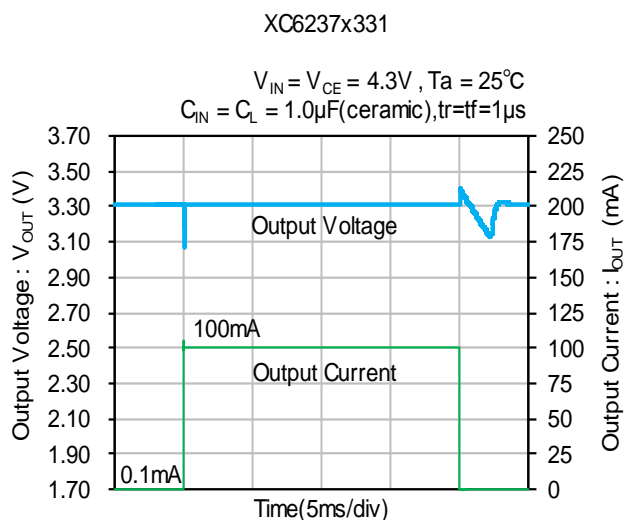
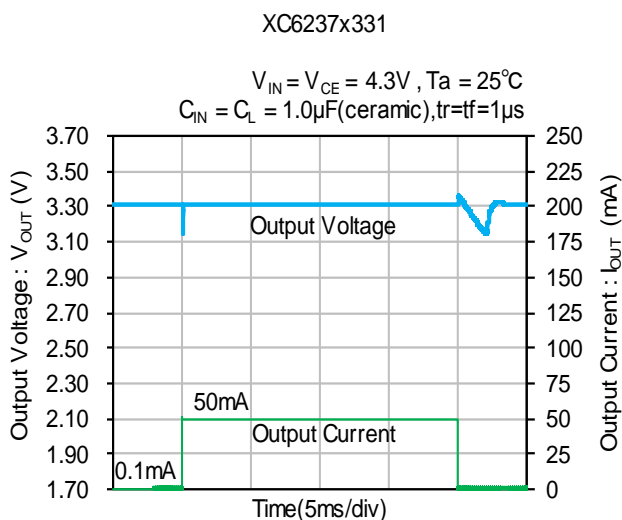
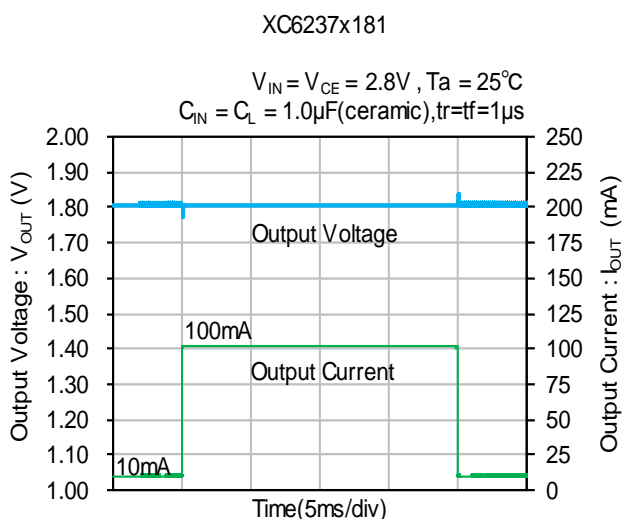
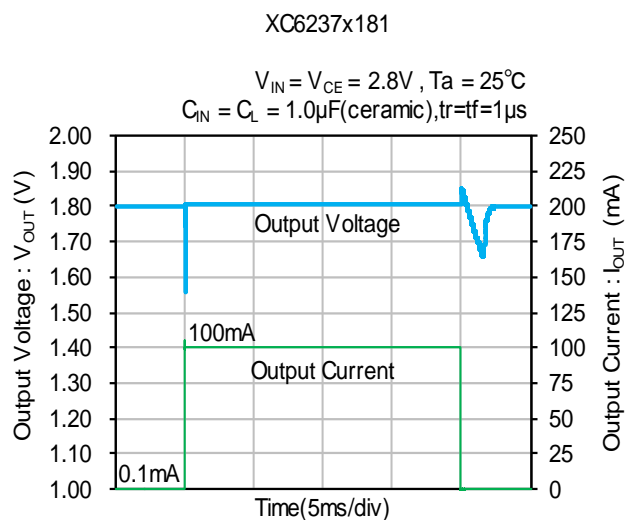
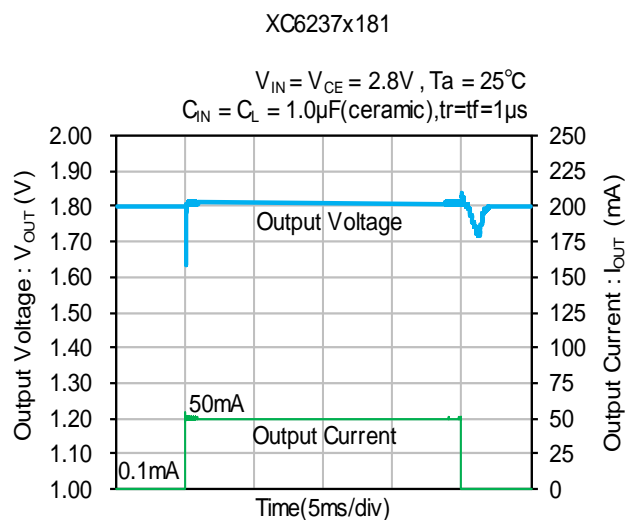

TYPICAL PERFORMANCE CHARACTERISTICS (Continued)

(8) Load Transient Response (Continued)

XC6237x331

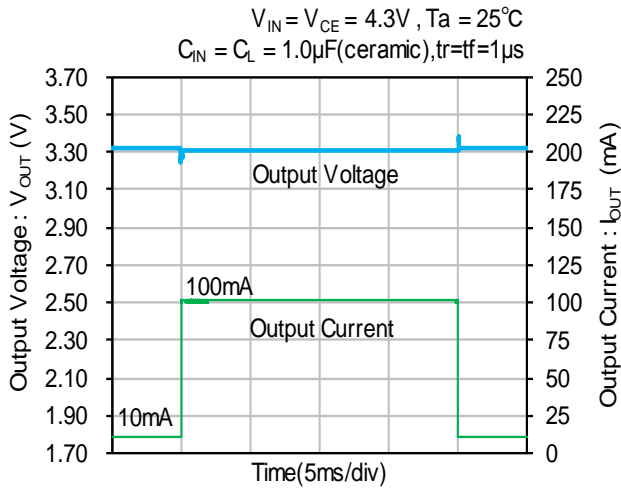

XC6237x501

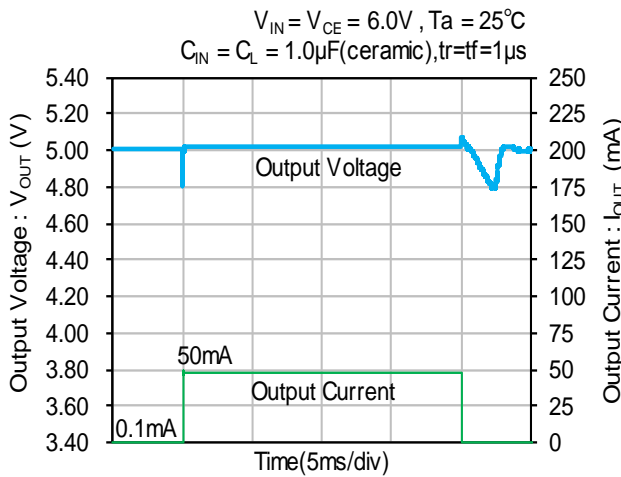

XC6237x501

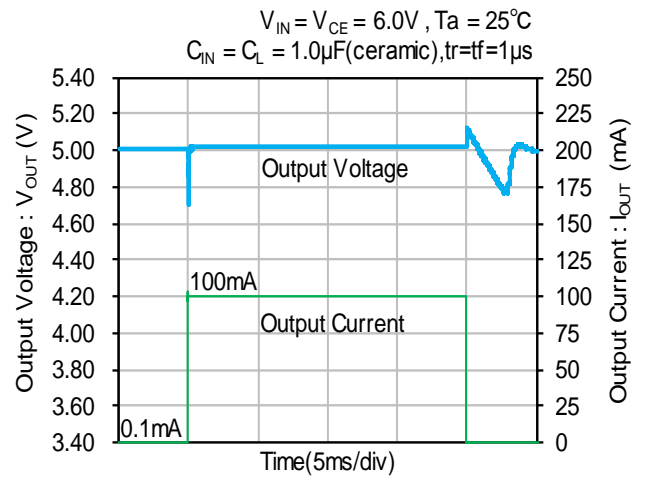

XC6237x501

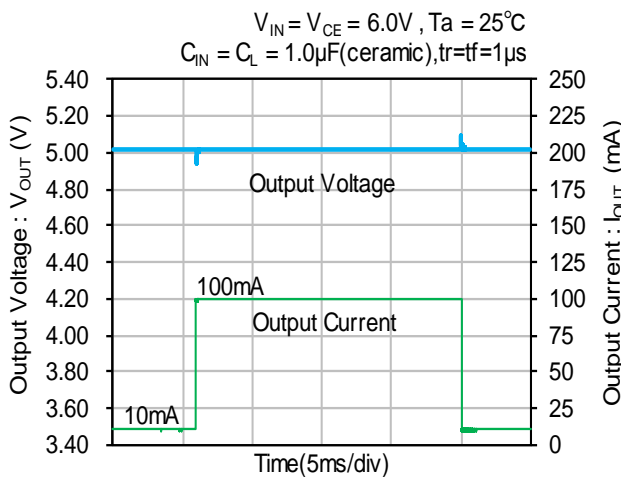

■ TYPICAL PERFORMANCE CHARACTERISTICS (Continued)

(9) Line Transient Response

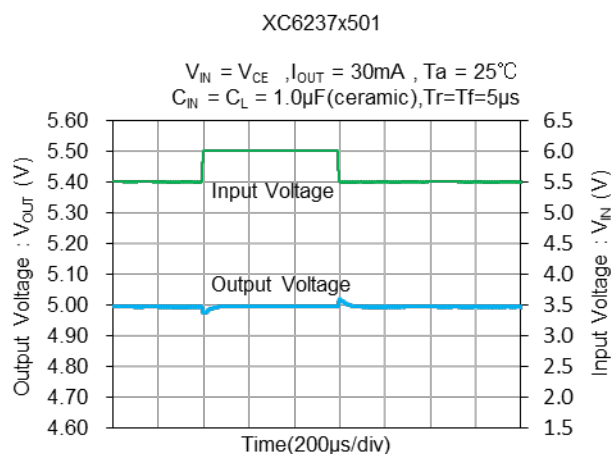
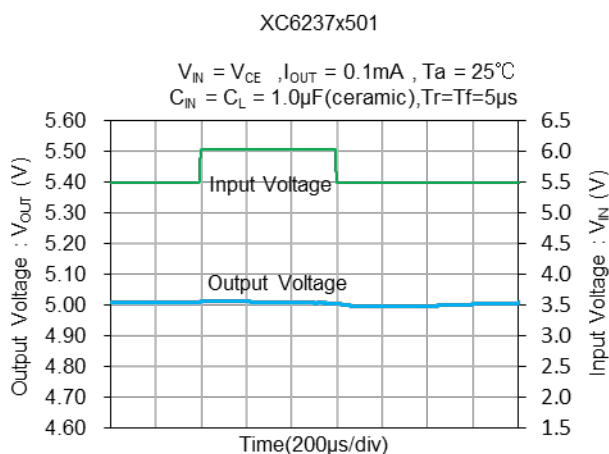
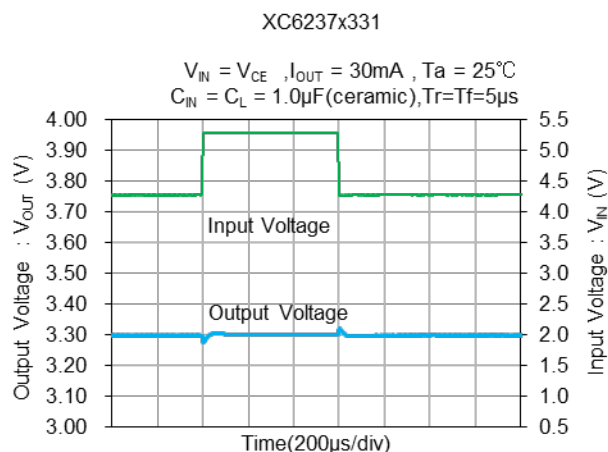
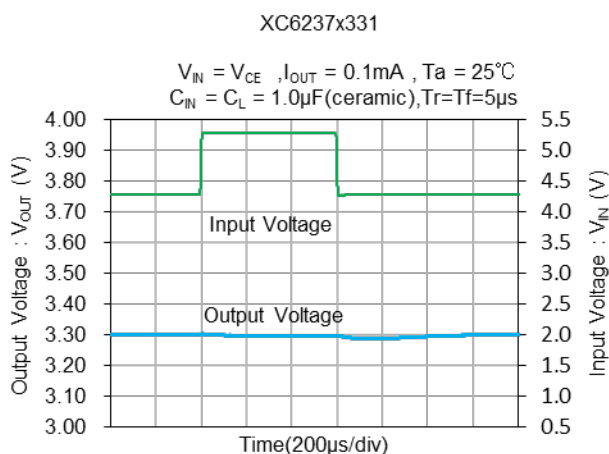
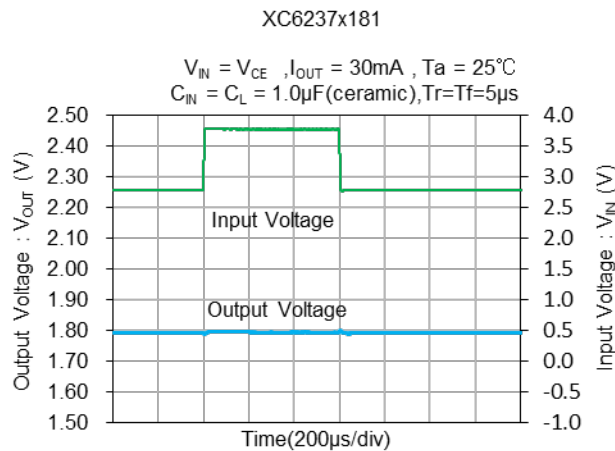
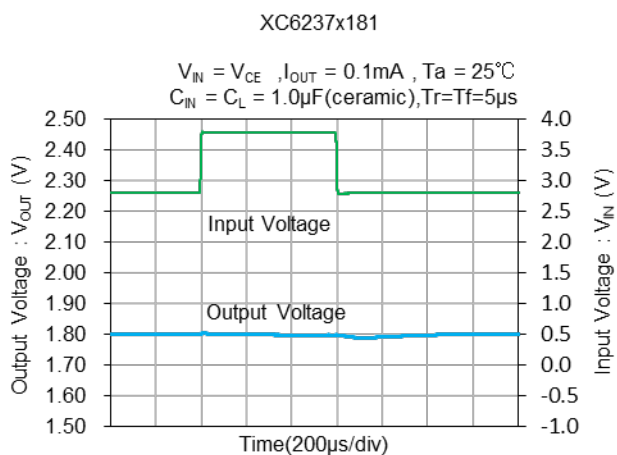

TYPICAL PERFORMANCE CHARACTERISTICS (Continued)

(10) Turn-On Response

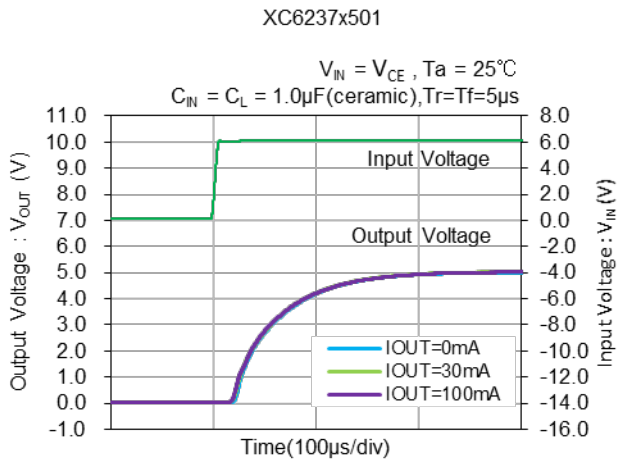
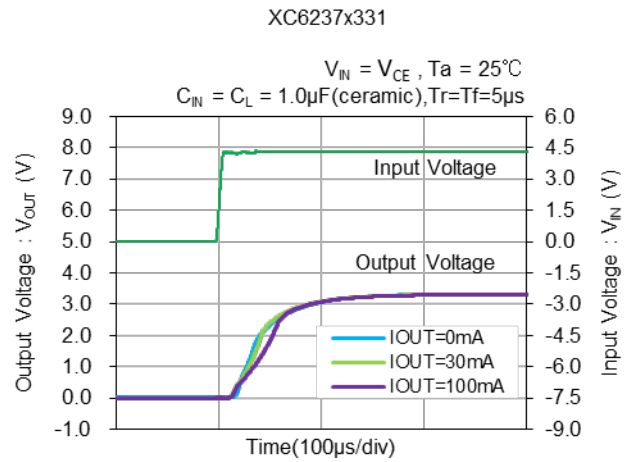
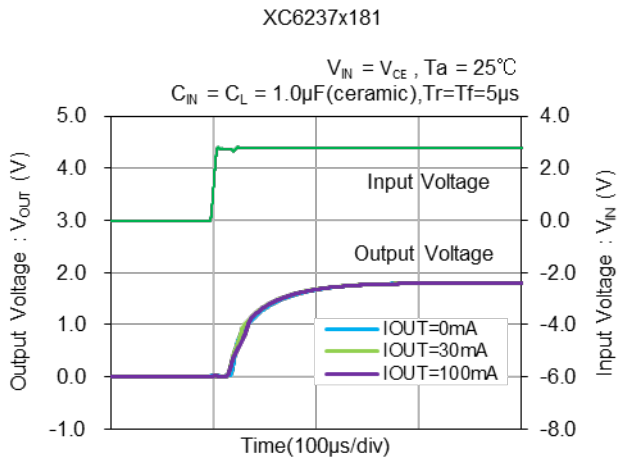

■ TYPICAL PERFORMANCE CHARACTERISTICS (Continued)

(11) CE Transient Response

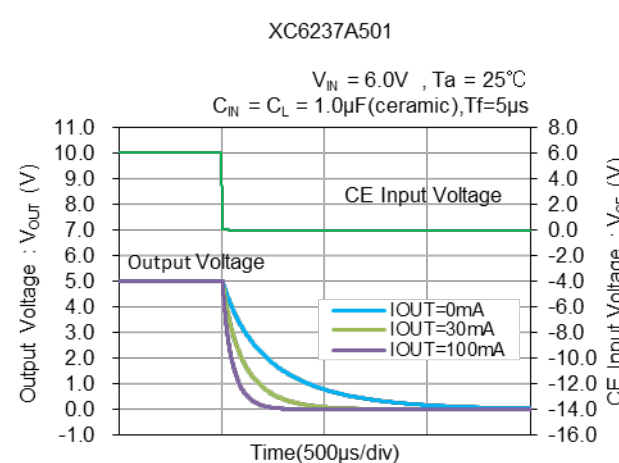
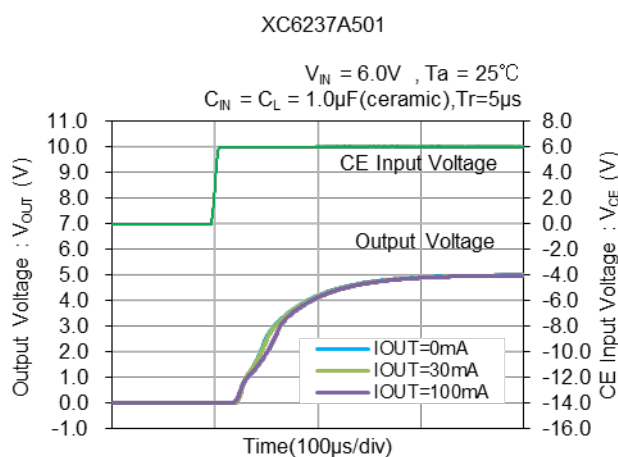
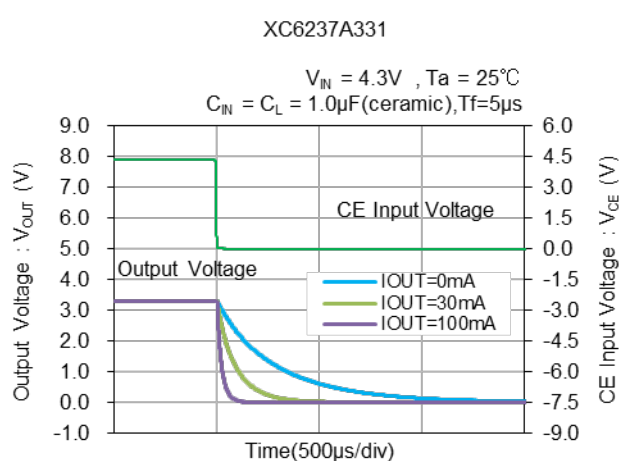
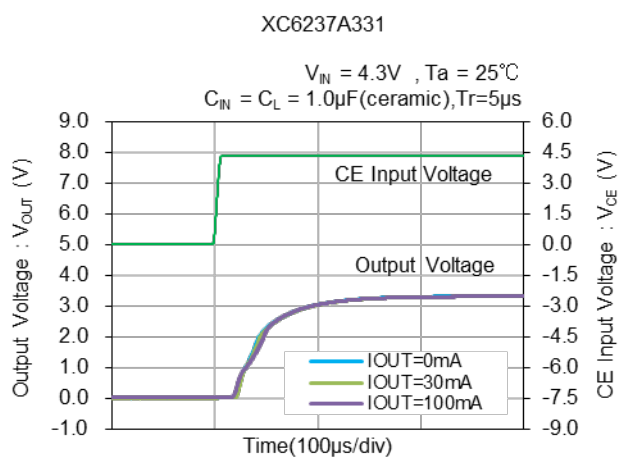
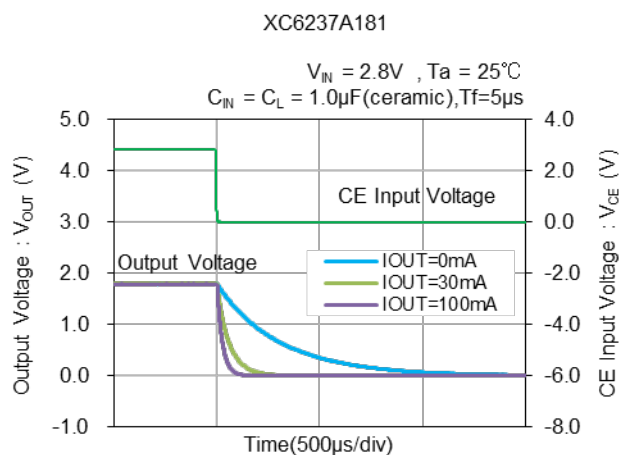
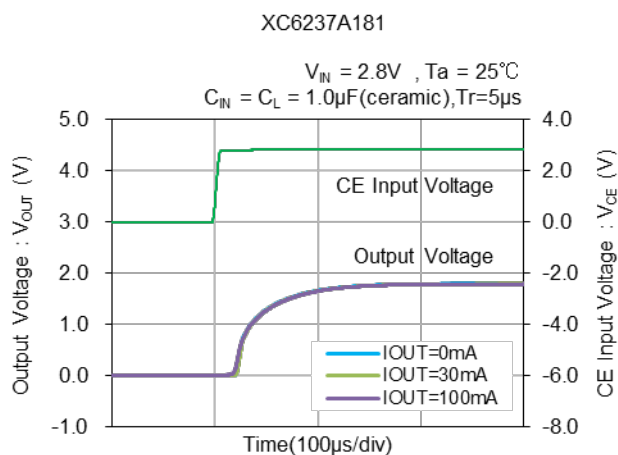

TYPICAL PERFORMANCE CHARACTERISTICS (Continued)

(12) Inrush Current Response

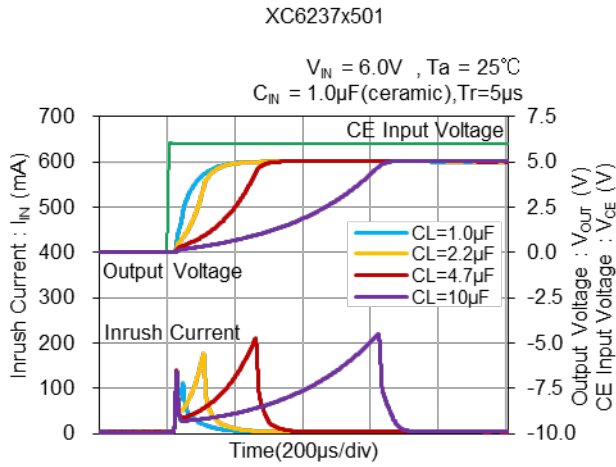
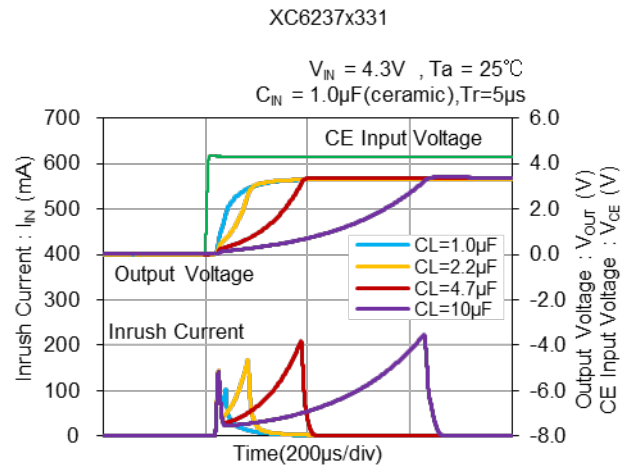
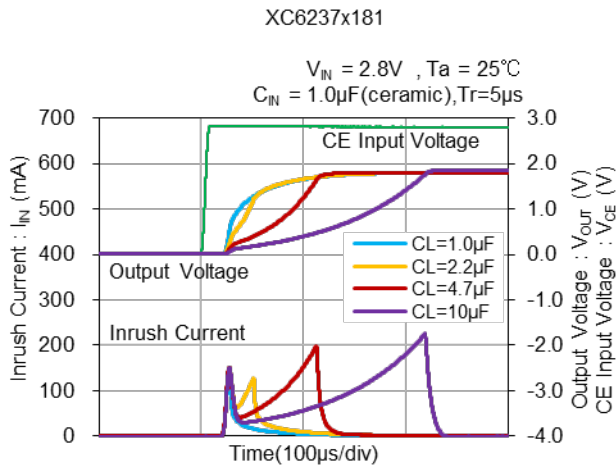

■ TYPICAL PERFORMANCE CHARACTERISTICS (Continued)

(13) Ripple Rejection: PSRR

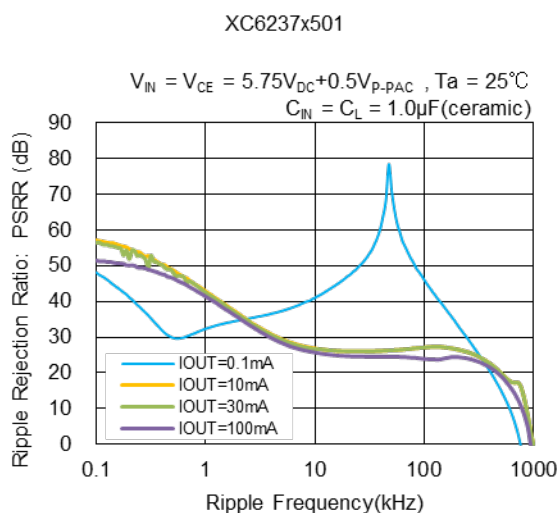
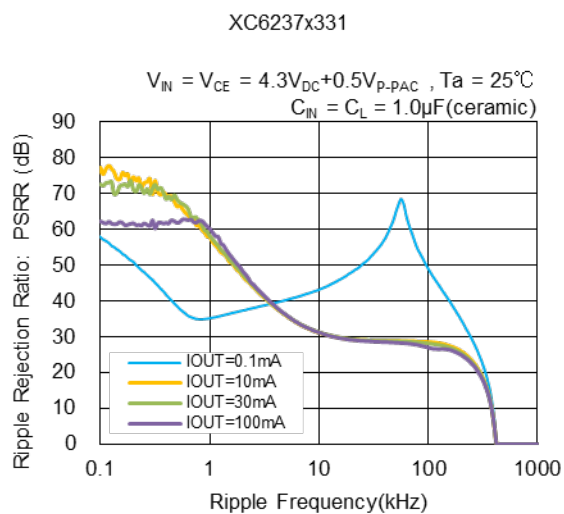
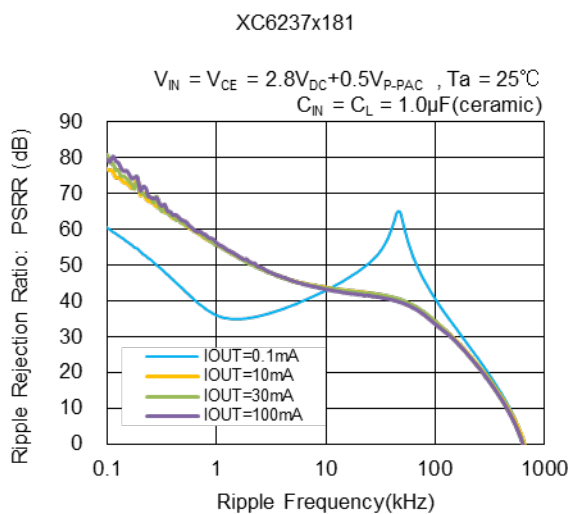

■ PACKAGING INFORMATION

For the latest package information go to, www.torexsemi.com/technical-support/packages

PACKAGE	OUTLINE / LAND PATTERN	THERMAL CHARACTERISTICS	
USPQ-4B05	USPQ-4B05 PKG	Standard Board	USPQ-4B05 Power Dissipation
SSOT-24	SSOT-24 PKG	Standard Board	SSOT-24 Power Dissipation
		JESD51-7 Board	
SOT-23	SOT-23 PKG	Standard Board	SOT-23 Power Dissipation

MARKING RULE

SSOT-24 / USPQ-4B05

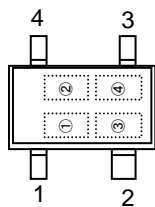

SSOT-24(Mark on bar view)

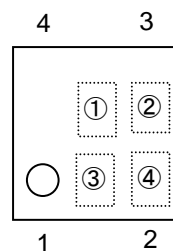

USPQ-4B05 (Mark on bar view)

①: represents type and the second decimal place of the output voltage

Type	SYMBOL	Output Voltage Range(V)	Product Series
With CE function and CL Auto-Discharge	B	1.20~2.15	XC6237A*****-G
	D	2.20~3.15	
	F	3.20~4.15	
	K	4.20~5.00	
With CE function	P	1.20~2.15	XC6237B*****-G
	S	2.20~3.15	
	U	3.20~4.15	
	X	4.20~5.00	

※ Mark on bar view

②: represents output voltage

SYMBOL	Output Voltage(V)				SYMBOL	Output Voltage(V)				SYMBOL	Output Voltage(V)			
A	1.20	2.20	3.20	4.20	K	1.55	2.55	3.55	4.55	T	1.90	2.90	3.90	4.90
B	1.25	2.25	3.25	4.25	L	1.60	2.60	3.60	4.60	U	1.95	2.95	3.95	4.95
C	1.30	2.30	3.30	4.30	M	1.65	2.65	3.65	4.65	V	2.00	3.00	4.00	5.00
D	1.35	2.35	3.35	4.35	N	1.70	2.70	3.70	4.70	X	2.05	3.05	4.05	-
E	1.40	2.40	3.40	4.40	P	1.75	2.75	3.75	4.75	Y	2.10	3.10	4.10	-
F	1.45	2.45	3.45	4.45	R	1.80	2.80	3.80	4.80	Z	2.15	3.15	4.15	-
H	1.50	2.50	3.50	4.50	S	1.85	2.85	3.85	4.85					

③,④: represents production lot number.01~09, 0A~0Z, 11~9Z, A1~A9, AA~AZ, B1~ZZ in order.
(G, I, J, O, Q, W excluded) * No character inversion used.

MARKING RULE

●SOT-23

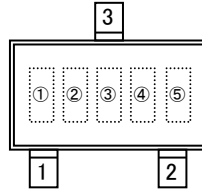

SOT-23

①: represents products series

Type	SYMBOL	Product Series
3pin regulator (Not CE function)	7	XC6237C****-G

②: represents type and the second decimal place of the output voltage

SYMBOL	Output Voltage Range(V)	Product Series
A	1.20~2.15	XC6237C12***-G ~ XC6237C21***-G
B	2.20~3.15	XC6237C22***-G ~ XC6237C31***-G
C	3.20~4.15	XC6237C32***-G ~ XC6237C41***-G
D	4.20~5.00	XC6237C42***-G ~ XC6237C501**-G

③: represents output voltage

SYMBOL	Output Voltage(V)				SYMBOL	Output Voltage(V)				SYMBOL	Output Voltage(V)			
A	1.20	2.20	3.20	4.20	K	1.55	2.55	3.55	4.55	T	1.90	2.90	3.90	4.90
B	1.25	2.25	3.25	4.25	L	1.60	2.60	3.60	4.60	U	1.95	2.95	3.95	4.95
C	1.30	2.30	3.30	4.30	M	1.65	2.65	3.65	4.65	V	2.00	3.00	4.00	5.00
D	1.35	2.35	3.35	4.35	N	1.70	2.70	3.70	4.70	X	2.05	3.05	4.05	-
E	1.40	2.40	3.40	4.40	P	1.75	2.75	3.75	4.75	Y	2.10	3.10	4.10	-
F	1.45	2.45	3.45	4.45	R	1.80	2.80	3.80	4.80	Z	2.15	3.15	4.15	-
H	1.50	2.50	3.50	4.50	S	1.85	2.85	3.85	4.85					

④⑤ represents production lot number.01~09, 0A~0Z, 11~9Z, A1~A9, AA~AZ, B1~ZZ in order.
(G, I, J, O, Q, W excluded)* No character inversion used.

1. The product and product specifications contained herein are subject to change without notice to improve performance characteristics. Consult us, or our representatives before use, to confirm that the information in this datasheet is up to date.
2. The information in this datasheet is intended to illustrate the operation and characteristics of our products. We neither make warranties or representations with respect to the accuracy or completeness of the information contained in this datasheet nor grant any license to any intellectual property rights of ours or any third party concerning with the information in this datasheet.
3. Applicable export control laws and regulations should be complied and the procedures required by such laws and regulations should also be followed, when the product or any information contained in this datasheet is exported.
4. The product is neither intended nor warranted for use in equipment of systems which require extremely high levels of quality and/or reliability and/or a malfunction or failure which may cause loss of human life, bodily injury, serious property damage including but not limited to devices or equipment used in 1) nuclear facilities, 2) aerospace industry, 3) medical facilities, 4) automobile industry and other transportation industry and 5) safety devices and safety equipment to control combustions and explosions. Do not use the product for the above use unless agreed by us in writing in advance.
5. Although we make continuous efforts to improve the quality and reliability of our products; nevertheless Semiconductors are likely to fail with a certain probability. So in order to prevent personal injury and/or property damage resulting from such failure, customers are required to incorporate adequate safety measures in their designs, such as system fail safes, redundancy and fire prevention features.
6. Our products are not designed to be Radiation-resistant.
7. Please use the product listed in this datasheet within the specified ranges.
8. We assume no responsibility for damage or loss due to abnormal use.
9. All rights reserved. No part of this datasheet may be copied or reproduced unless agreed by Torex Semiconductor Ltd in writing in advance.

TOREX SEMICONDUCTOR LTD.

单击下面可查看定价，库存，交付和生命周期等信息

[>>Torex Semiconductor\(特瑞仕\)](#)