

Positive Voltage Regulator with (Output ON/OFF)

■ GENERAL DESCRIPTION

The XC62H series are highly precise, low power consumption, positive voltage regulators, manufactured using CMOS and laser trimming technologies. The series consists of a high precision voltage reference, an error correction circuit, and an output driver with current limitation.

By way of the CE function, with output turned off, the series enters standby. In the stand-by mode, power consumption is greatly reduced.

SOT-25 (150mW), SOT-89-5 (500mW) and USP-6B (120mW) packages are available.

■ APPLICATIONS

- Multi-function power supplies
- Voltage supplies for cellular phones
- Digital still cameras / Camcorders
- Note PC / Tablet PC

■ FEATURES

Maximum Output Current

: 165mA (within max Pd, $V_{OUT}=3.0V$)

Output Voltage Range: 2.0V ~ 6.0V (0.1V increments)

(1.5V ~ 1.9V semi-custom)

Highly Accurate

: $\pm 2\%$

($\pm 1\%$ for semi-custom products)

Low Power Consumption

: 3 μA (TYP.) ($V_{OUT}=3V$, Output enabled)

: 0.1 μA (TYP.) (Output disabled)

Output Voltage Temperature Characteristics

: $\pm 100\text{ppm}/^\circ\text{C}$ (TYP.)

Line Regulation

: 0.2% / V (TYP.)

CMOS Low Power Consumption**Dropout Voltage**

: 0.18V @ 60mA

: 0.58V @ 160mA

Packages

: SOT-25

SOT-89-5

USP-6B

Environmentally Friendly :EU RoHS Compliant, Pb Free

■ TYPICAL APPLICATION CIRCUIT

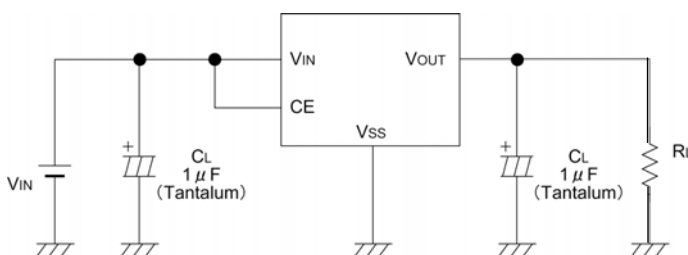

■ TYPICAL PERFORMANCE CHARACTERISTICS

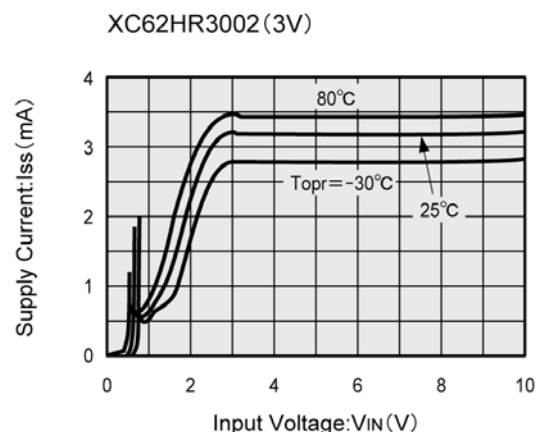

PIN CONFIGURATION

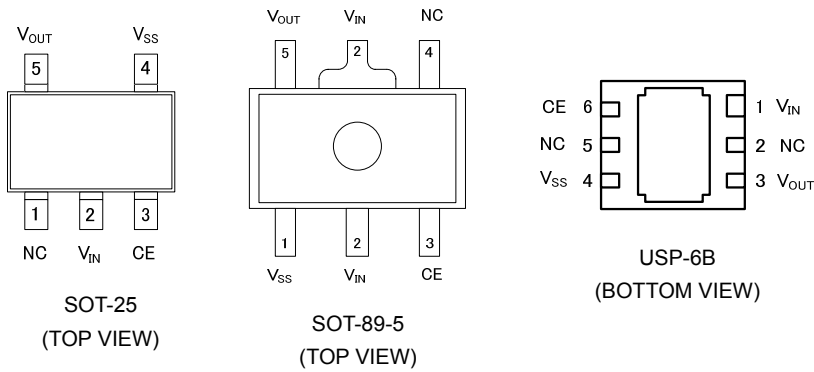

*The dissipation pad for the USP-6B package should be solder-plated in recommended mount pattern and metal masking so as to enhance mounting strength and heat release. If the pad needs to be connected to other pins, it should be connected to the VIN (No.1) pin.

PIN ASSIGNMENT

PIN NUMBER			PIN NAME	FUNCTIONS
SOT-25	SOT-89-5	USP-6B		
1	4	2, 5	NC	No Connection
2	2	1	V _{IN}	Supply Voltage Input
3	3	6	CE	ON/OFF Chip Enable
4	1	4	V _{SS}	Ground
5	5	3	V _{OUT}	Regulated Output Voltage

FUNCTIONS

CE	OPERATION
L	OFF
H	ON
OPEN	Undefined state

PRODUCT CLASSIFICATION

Ordering Information

XC62H①②③④⑤⑥⑦-⑧^(*)

DESIGNATOR	ITEM	SYMBOL	DESCRIPTION
①	CE Pin Logic	R	Positive
②③	Output Voltage	20~60	e.g. V _{OUT} 3.0V → ②=3, ③=0 V _{OUT} 5.0V → ②=5, ③=0
④	Temperature Characteristics	0	± 100ppm (TYP.)
⑤	Output Voltage Accuracy	1	± 1% (semi-custom)
		2	± 2%
⑥⑦-⑧	Packages (Order Unit)	MR	SOT-25 (3,000/Reel)
		MR-G	SOT-25 (3,000/Reel)
		PR	SOT-89-5 (1,000/Reel)
		PR-G	SOT-89-5 (1,000/Reel)
		DR	USP-6B (3,000/Reel)
		DR-G	USP-6B (3,000/Reel)

^(*) The "-G" suffix denotes Halogen and Antimony free as well as being fully EU RoHS compliant.

■ BLOCK DIAGRAM

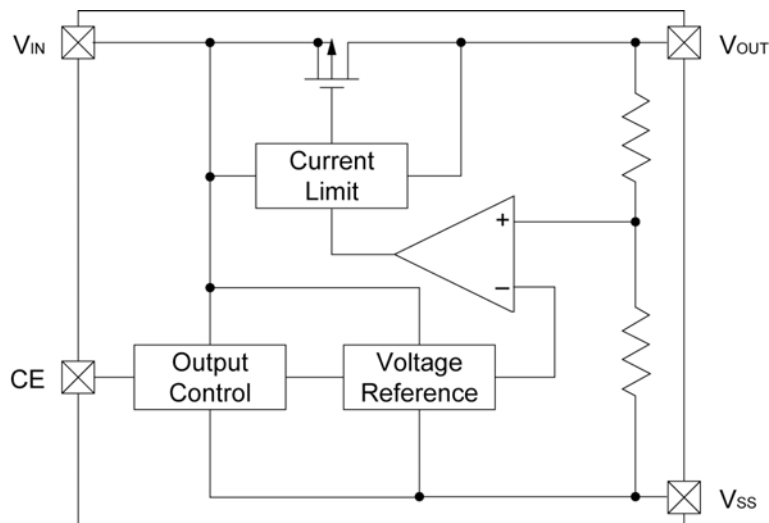

■ ABSOLUTE MAXIMUM RATINGS

Ta=25°C

PARAMETER	SYMBOL	RATINGS	UNITS
Input Voltage	V _{IN}	12.0	V
Output Current	I _{OUT}	500 ^(*)	mA
Output Voltage	V _{OUT}	V _{SS} -0.3 ~ V _{IN} +1.3	V
CE Input Voltage	V _{CE}	V _{SS} -0.3 ~ V _{IN} +1.3	V
Power Dissipation	SOT-25	150	mW
	SOT-89-5	500	
	USP-6B	120	
Operating Ambient Temperature	T _{opr}	-30 ~ +80	°C
Storage Temperature	T _{stg}	-40 ~ +125	°C

(*) Please use within the range of $I_{OUT} \leq Pd / (V_{IN} - V_{OUT})$

ELECTRICAL CHARACTERISTICS

● Low Voltage

Ta=25°C

PARAMETER	SYMBOL	CONDITIONS	MIN	TYP	MAX	UNITS	CIRCUIT
Output Voltage	$V_{OUT(E)}^{(*2)}$	$V_{IN}=V_{OUT(T)}^{(*1)}+1.0V$ $I_{OUT}=0.5mA$	$\times 0.98$ $E1-1^{(*7)}$	$V_{OUT(T)}$	$\times 1.02$ $E1-2^{(*7)}$	V	1
Maximum Output Current	I_{OUTmax}	$V_{IN}=V_{OUT(T)}+1.0V$ $V_{OUT(E)} \geq V_{OUT(T)} \times 0.9$	$E2^{(*7)}$			mA	1
Load Regulation	ΔV_{OUT}	$V_{IN}=V_{OUT(T)}+1.0V$ $1mA \leq I_{OUT} \leq 30mA$		15	40	mV	1
Dropout Voltage ^(*3)	Vdif	Output Voltage: 1.5 ~ 1.7V $I_{OUT}=10mA, V_{CE}=V_{IN}$	1.0		500	mV	1
		Output Voltage: 1.8 ~ 1.9V $I_{OUT}=20mA, V_{CE}=V_{IN}$	1.0		300		
Supply Current 1	I_{SS1}	$V_{IN}=V_{CE}=V_{OUT(T)}+1.0V$	2.0		6.8	μA	2
Supply Current 2	I_{SS2}	$V_{IN}=V_{OUT(T)}+1.0V, V_{CE}=V_{SS}$			0.1	μA	2
Line Regulation	$\frac{\Delta V_{OUT}}{(\Delta V_{IN} \cdot V_{OUT})}$	$I_{OUT}=0.5mA$ $V_{OUT(T)}+1.0V \leq V_{IN} \leq 10V$		0.15	0.25	%/V	1
Input Voltage	V_{IN}		2		10	V	-
Output Voltage Temperature Characteristics	$\frac{\Delta V_{OUT}}{(\Delta T_{opr} \cdot V_{OUT})}$	$I_{OUT}=0.5mA$ $-30^{\circ}C \leq T_{opr} \leq 80^{\circ}C$		± 100		ppm/°C	1
CE "High" Voltage	V_{CEH}		1.5			V	1
CE "Low" Voltage	V_{CEL}				0.25	V	1
CE "High" Current	I_{CEH}	$V_{CE}=V_{IN}$			0.1	μA	2
CE "Low" Current	I_{CEL}	$V_{CE}=V_{SS}$	-0.2	-0.05	0	μA	2

NOTE:

*1: $V_{OUT(T)}$ =Specified output voltage .

*2: $V_{OUT(E)}$ =Effective output voltage (i.e. the output voltage when " $V_{OUT(T)}+1.0V$ " is provided at the V_{IN} pin while maintaining a certain I_{OUT} value).

*3: $Vdif = \{V_{IN1}^{(*5)} - V_{OUT1}^{(*4)}\}$

*4: V_{OUT1} = A voltage equal to 98% of the output voltage whenever an amply stabilized $I_{OUT} \{V_{OUT(T)}+1.0V\}$ is input.

*5: V_{IN1} = The input voltage when V_{OUT1} appears as input voltage is gradually decreased.

*6: Over $V_{IN}=2.0V$ of input voltage is necessary.

*7: Refer to the "Voltage chart"

■ ELECTRICAL CHARACTERISTICS (Continued)

● Low Voltage Chart

SYMBOL	E1-1	E1-2	E2
PARAMETER	OUTPUT VOLTAGE (V)		MAXIMUM OUTPUT CURRENT (mA)
SETTING OUTPUT VOLTAGE(V)	$V_{OUT(E)}$		I_{OUTmax}
$V_{OUT(T)}$	MIN	MAX	MIN
1.5	1.470	1.530	60
1.6	1.568	1.632	70
1.7	1.666	1.734	80
1.8	1.764	1.836	90
1.9	1.862	1.938	100

Note) The symbol is as same as that in the chart of electrical characteristics.

ELECTRICAL CHARACTERISTICS (Continued)

● Standard Voltage

Ta=25°C

PARAMETER	SYMBOL	CONDITIONS	MIN	TYP	MAX	UNITS	CIRCUIT
Output Voltage (2%)	$V_{OUT(E)}^{(*)2}$	$V_{IN}=V_{OUT(T)}^{(*)1}+1.0V$	×0.98	$V_{OUT(T)}$ E1 ^{(*)6}	×1.02	V	1
Output Voltage (1%)		$I_{OUT}=40mA$	×0.99		×1.01		
Maximum Output Current	I_{OUTmax}	$V_{IN}=V_{OUT(T)}+1.0V$ $V_{OUT(E)} \geq V_{OUT(T)} \times 0.9$	E2 ^{(*)6}			mA	1
Load Regulation	ΔV_{OUT}	$V_{IN}=V_{OUT(T)}+1.0V$ $1mA \leq I_{OUT} \leq \{C1^{(*)7}\}mA$		E3-1 ^{(*)6}	E3-2 ^{(*)6}	mV	1
Dropout Voltage ^{(*)3}	Vdif	$I_{OUT}=\{C2^{(*)7}\}mA$		E4-1 ^{(*)6}	E4-2 ^{(*)6}	mV	1
	Vdif	$I_{OUT}=\{C3^{(*)7}\}mA$		E5-1 ^{(*)6}	E5-2 ^{(*)6}	mV	1
Supply Current 1	I_{SS1}	$V_{IN}=V_{CE}=V_{OUT(T)}+1.0V$		E6-1 ^{(*)6}	E6-2 ^{(*)6}	μA	2
Supply Current 2	I_{SS2}	$V_{IN}=V_{OUT(T)}+1.0V, V_{CE}=V_{SS}$			0.1	μA	2
Line Regulation	$\frac{\Delta V_{OUT}}{(\Delta V_{IN} \cdot V_{OUT})}$	$I_{OUT}=40mA$ $V_{OUT(T)}+1.0V \leq V_{IN} \leq 10.0V$		0.2	0.3	%/V	1
Input Voltage	V_{IN}				10	V	-
Output Voltage Temperature Characteristics	$\frac{\Delta V_{OUT}}{(\Delta T_{opr} \cdot V_{OUT})}$	$I_{OUT}=40mA$ $-30^{\circ}C \leq T_{opr} \leq 80^{\circ}C$		±100		ppm/°C	1
CE "High" Voltage	V_{CEH}		1.5			V	1
CE "Low" Voltage	V_{CEL}				0.25	V	1
CE "High" Current	I_{CEH}	$V_{CE}=V_{IN}$			0.1	μA	2
CE "Low" Current	I_{CEL}	$V_{CE}=V_{SS}$	-0.2	-0.05	0	μA	2

NOTE:

*1: $V_{OUT(T)}$ =Specified output voltage .

*2: $V_{OUT(E)}$ =Effective output voltage (i.e. the output voltage when " $V_{OUT(T)}+1.0V$ " is provided at the V_{IN} pin while maintaining a certain I_{OUT} value).

3: $Vdif = \{V_{IN1}^{()5} - V_{OUT1}^{(*)4}\}$

*4: V_{OUT1} = A voltage equal to 98% of the output voltage whenever an amply stabilized I_{OUT} ($V_{OUT(T)}+1.0V$) is input.

*5: V_{IN1} = The input voltage when V_{OUT1} appears as input voltage is gradually decreased.

*6: Refer to the "Standard Voltage, Voltage chart"

*7: Refer to the "Voltage chart "

■ ELECTRICAL CHARACTERISTICS (Continued)

● Standard Voltage, Voltage chart

SYMBOL	E1-1	E1-2			E2	E3-1	E3-2	E4-1	E4-2	E5-1	E5-2	E6-1	E6-2
PARAMETER SETTING OUTPUT VOLTAGE(V)	OUTPUT VOLTAGE (V) (2% products)		OUTPUT VOLTAGE (V) (1% products)		MAXIMUM OUTPUT CURRENT (mA)	LOAD REGULATION (mV)		DROPOUT VOLTAGE (mV)				SUPPLY CURRENT1 (μ A)	
$V_{OUT(T)}$	$V_{OUT(E)}$		$V_{OUT(E)}$		I_{OUTmax}	ΔV_{OUT}		V_{dif1}		V_{dif2}		I_{SS1}	
	MIN	MAX	MIN	MAX	MIN	TYP	MAX	TYP	MAX	TYP	MAX	TYP	MAX
2.0	1.960	2.040	1.980	2.020	115	45	90	180	360	580	880	2.9	7.9
2.1	2.058	2.142	2.079	2.121	115	45	90	180	360	580	880	2.9	7.9
2.2	2.156	2.244	2.178	2.222	115	45	90	180	360	580	880	2.9	7.9
2.3	2.254	2.346	2.277	2.323	115	45	90	180	360	580	880	2.9	7.9
2.4	2.352	2.448	2.376	2.424	115	45	90	180	360	580	880	2.9	7.9
2.5	2.450	2.550	2.475	2.525	115	45	90	180	360	580	880	2.9	7.9
2.6	2.548	2.652	2.574	2.626	115	45	90	180	360	580	880	2.9	7.9
2.7	2.646	2.754	2.673	2.727	115	45	90	180	360	580	880	2.9	7.9
2.8	2.744	2.856	2.772	2.828	115	45	90	180	360	580	880	2.9	7.9
2.9	2.842	2.958	2.871	2.929	115	45	90	180	360	580	880	2.9	7.9
3.0	2.940	3.060	2.970	3.030	165	45	90	180	360	580	880	2.9	7.9
3.1	3.038	3.162	3.069	3.131	165	45	90	180	360	580	880	3.0	8.0
3.2	3.136	3.264	3.168	3.232	165	45	90	180	360	580	880	3.0	8.0
3.3	3.234	3.366	3.267	3.333	165	45	90	180	360	580	880	3.0	8.0
3.4	3.332	3.468	3.366	3.434	165	45	90	180	360	580	880	3.0	8.0
3.5	3.430	3.570	3.465	3.535	165	45	90	180	360	580	880	3.0	8.0
3.6	3.528	3.672	3.564	3.636	165	45	90	180	360	580	880	3.0	8.0
3.7	3.626	3.774	3.663	3.737	165	45	90	180	360	580	880	3.0	8.0
3.8	3.724	3.876	3.762	3.838	165	45	90	180	360	580	880	3.0	8.0
3.9	3.822	3.978	3.861	3.939	165	45	90	180	360	580	880	3.0	8.0
4.0	3.920	4.080	3.960	4.040	200	45	90	170	340	560	840	3.1	8.1
4.1	4.018	4.182	4.059	4.141	200	45	90	170	340	560	840	3.1	8.1
4.2	4.116	4.284	4.158	4.242	200	45	90	170	340	560	840	3.1	8.1
4.3	4.214	4.386	4.257	4.343	200	45	90	170	340	560	840	3.1	8.1
4.4	4.312	4.488	4.356	4.444	200	45	90	170	340	560	840	3.1	8.1
4.5	4.410	4.590	4.455	4.545	200	45	90	170	340	560	840	3.1	8.1
4.6	4.508	4.692	4.554	4.646	200	45	90	170	340	560	840	3.1	8.1
4.7	4.606	4.794	4.653	4.747	200	45	90	170	340	560	840	3.1	8.1
4.8	4.704	4.896	4.752	4.848	200	45	90	170	340	560	840	3.1	8.1
4.9	4.802	4.998	4.851	4.949	200	45	90	170	340	560	840	3.1	8.1
5.0	4.900	5.100	4.950	5.050	220	40	80	165	320	540	820	3.1	8.1
5.1	4.998	5.202	5.049	5.151	220	40	80	165	320	540	820	3.1	8.1
5.2	5.096	5.304	5.148	5.252	220	40	80	165	320	540	820	3.1	8.1
5.3	5.194	5.406	5.247	5.353	220	40	80	165	320	540	820	3.1	8.1
5.4	5.292	5.508	5.346	5.454	220	40	80	165	320	540	820	3.1	8.1
5.5	5.390	5.610	5.445	5.555	220	40	80	165	320	540	820	3.1	8.1
5.6	5.488	5.712	5.544	5.656	220	40	80	165	320	540	820	3.1	8.1
5.7	5.586	5.814	5.643	5.757	220	40	80	165	320	540	820	3.1	8.1
5.8	5.684	5.916	5.742	5.858	220	40	80	165	320	540	820	3.1	8.1
5.9	5.782	6.018	5.841	5.959	220	40	80	165	320	540	820	3.1	8.1
6.0	5.880	6.120	5.940	6.060	220	40	80	165	320	540	820	3.1	8.1

Note) The symbol is as same as that in the chart of electrical characteristics.

■ ELECTRICAL CHARACTERISTICS (Continued)

● Voltage Chart

SYMBOL	C1	C2	C3
PARAMETER	ΔV_{OUT}	Vdif1	Vdif2
SETTING	CONDITIONS	CONDITIONS	CONDITIONS
OUTPUT VOLTAGE(V)	(mA)	(mA)	(mA)
$V_{OUT(T)}$	I_{OUT}	I_{OUT}	I_{OUT}
	CONDITIONS	CONDITIONS	CONDITIONS
2.0	60	40	100
2.1	60	40	100
2.2	60	40	100
2.3	60	40	100
2.4	60	40	100
2.5	60	40	100
2.6	60	40	100
2.7	60	40	100
2.8	60	40	100
2.9	60	40	100
3.0	80	60	160
3.1	80	60	160
3.2	80	60	160
3.3	80	60	160
3.4	80	60	160
3.5	80	60	160
3.6	80	60	160
3.7	80	60	160
3.8	80	60	160
3.9	80	60	160
4.0	100	80	180
4.1	100	80	180
4.2	100	80	180
4.3	100	80	180
4.4	100	80	180
4.5	100	80	180
4.6	100	80	180
4.7	100	80	180
4.8	100	80	180
4.9	100	80	180
5.0	100	100	200
5.1	100	100	200
5.2	100	100	200
5.3	100	100	200
5.4	100	100	200
5.5	100	100	200
5.6	100	100	200
5.7	100	100	200
5.8	100	100	200
5.9	100	100	200
6.0	100	100	200

TEST CIRCUITS

Circuit 1

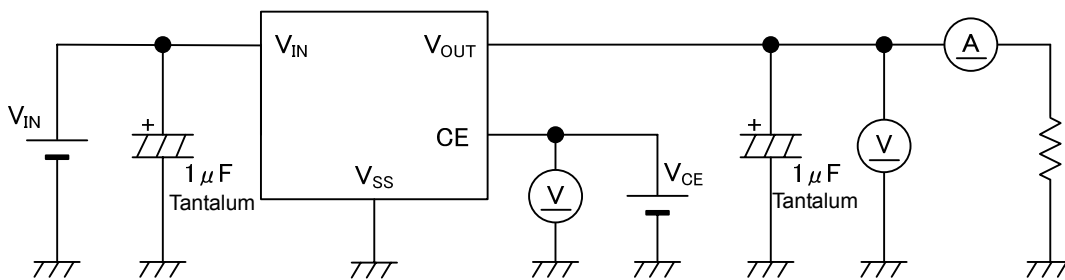

Circuit 2

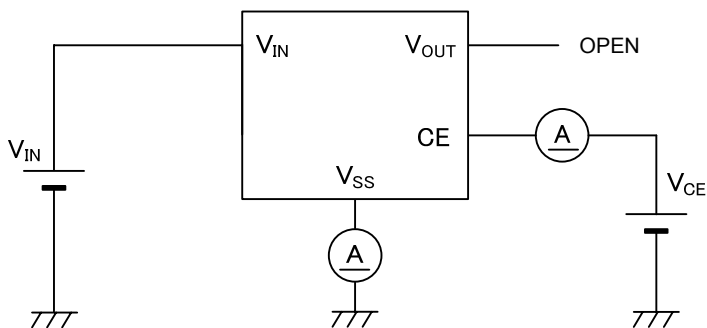

OPERATIONAL EXPLANATION

Output voltage control with the XC62H series:

The voltage divided by resistors R1 & R2 is compared with the internal reference voltage by the error amplifier.

The P-channel MOSFET, which is connected to the V_{OUT} pin, is then driven by the subsequent output signal.

The output voltage at the V_{OUT} pin is controlled & stabilized by a system of negative feedback.

The current limit circuit operate in relation to the level of output current.

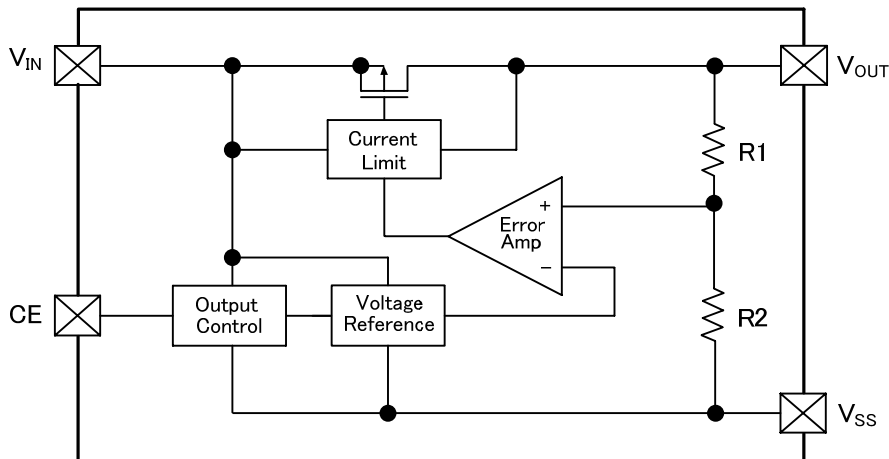

< Current Limiter >

The XC62H series has output current limiter of fixed current limiter circuit. When the output current reaches the current limit, the fixed current limiter circuit operates and the output voltage drops with keeping the output current.

<CE Pin>

The IC's internal circuitry can be operated or shutdown via the signal from the CE pin with the XC62H series. In shutdown mode, output at the V_{OUT} pin will be pulled down to the V_{SS} level via R1 & R2. Note that the XC62H series' regulator is "High Active/No Pull-Down", operations will become unstable with the CE pin open. We suggest that you use this IC with either a CE High level voltage or a CE Low level voltage input at the CE pin. If this IC is used with the correct specifications for the CE pin, the operational logic is fixed and the IC will operate normally. However, supply current may increase as a result of through current in the IC's internal circuitry.

<Input and Output Capacitors>

The XC62H series needs an output capacitor (C_L) for phase compensation. In order to ensure the stable phase compensation, please place an output capacitor of 1.0 μF at the V_{OUT} pin and V_{SS} pin as close as possible. For a stable power input, please connect an input capacitor (C_{IN}) of 1.0 μF between the input pin (V_{IN}) and the ground pin (V_{SS}).

NOTES ON USE

1. Please use this IC within the stated maximum ratings. For temporary, transitional voltage drop or voltage rising phenomenon, the IC is liable to malfunction should the ratings be exceeded.
2. Where wiring impedance is high, operations may become unstable due to noise and/or phase lag depending on output current. Please strengthen V_{IN} and V_{SS} wiring in particular.
3. Please wire the input capacitor (C_{IN}) and the output capacitor (C_L) as close to the IC as possible. Should rapid input fluctuation or load fluctuation occur, please increase the capacitor value such as C_{IN} or C_L to stabilize the operation.
4. Torex places an importance on improving our products and their reliability. We request that users incorporate fail-safe designs and post-aging protection treatment when using Torex products in their systems.

TYPICAL PERFORMANCE CHARACTERISTICS

(1) Output Voltage vs. Output Current

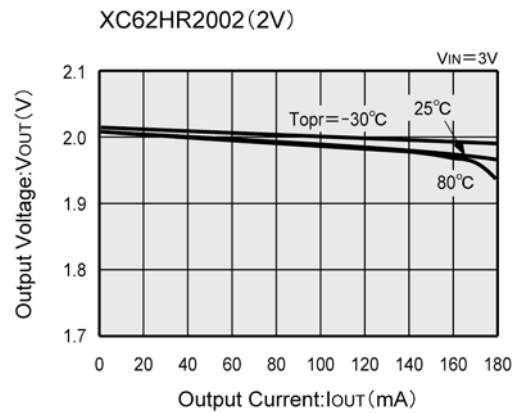
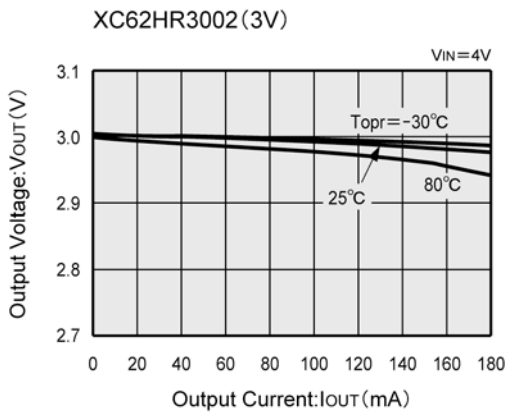
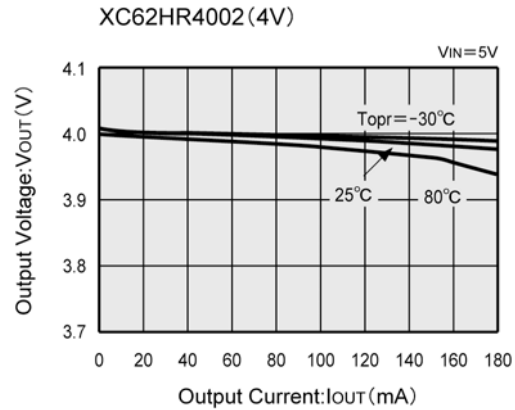
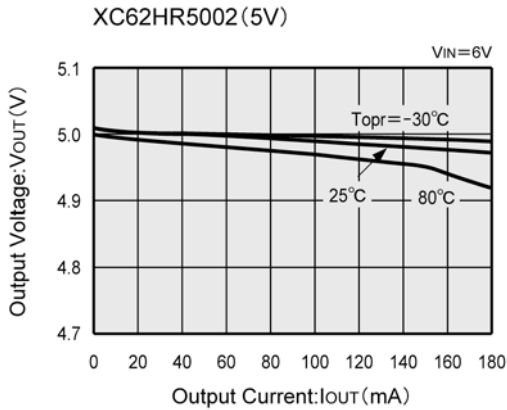

(2) Output Voltage vs. Input Voltage

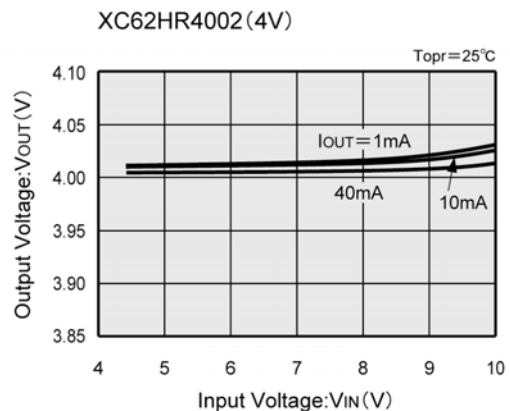
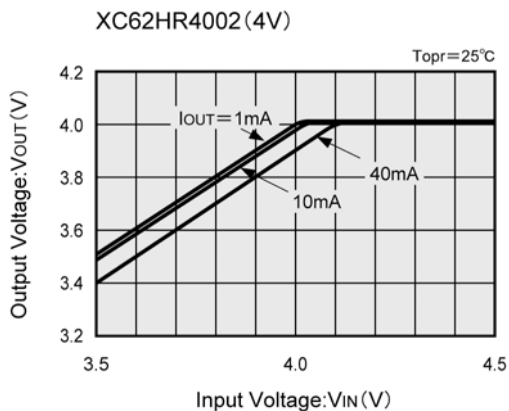
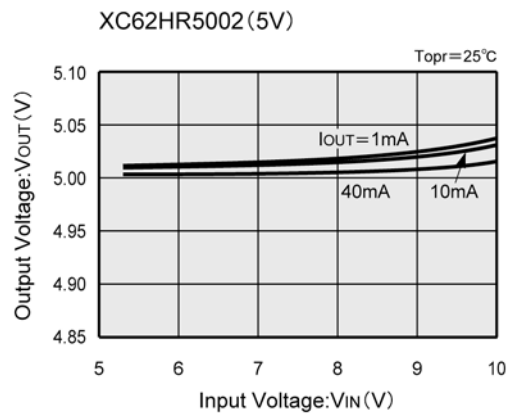
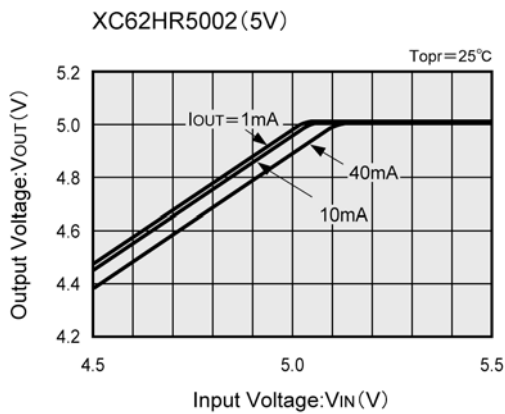

TYPICAL PERFORMANCE CHARACTERISTICS (Continued)

(2) Output Voltage vs. Input Voltage (Continued)

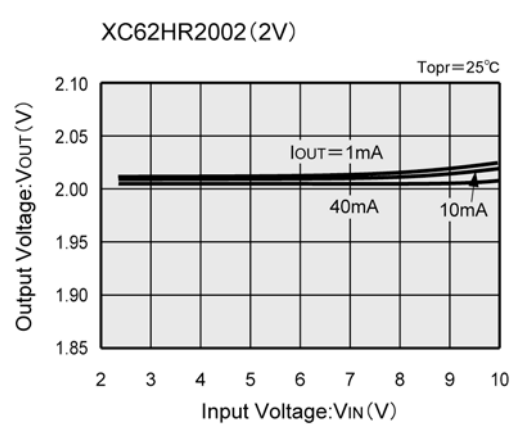
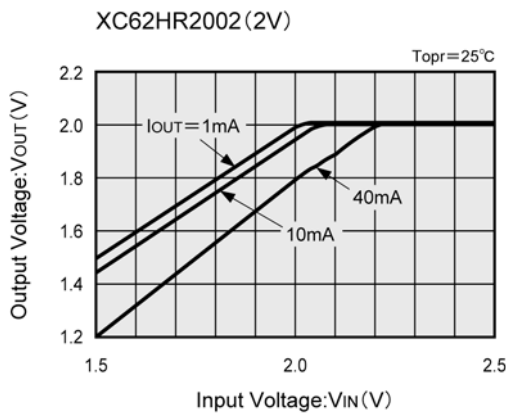
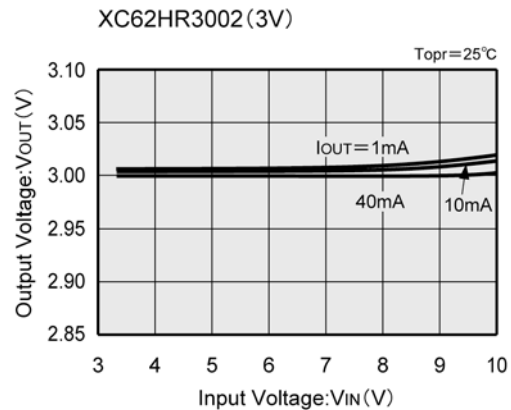
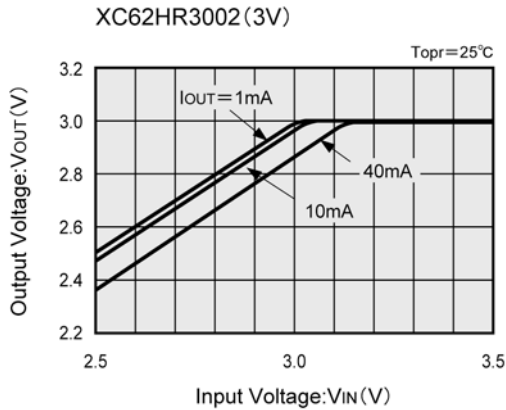

(3) Dropout Voltage vs. Output Current

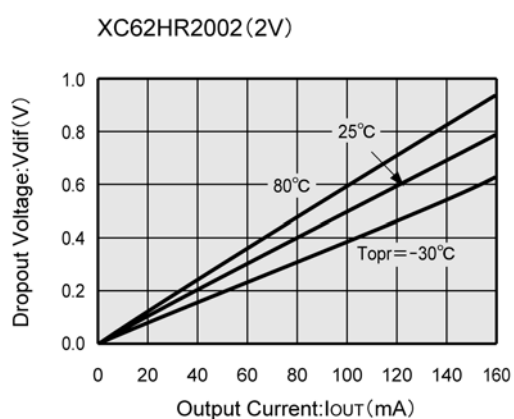
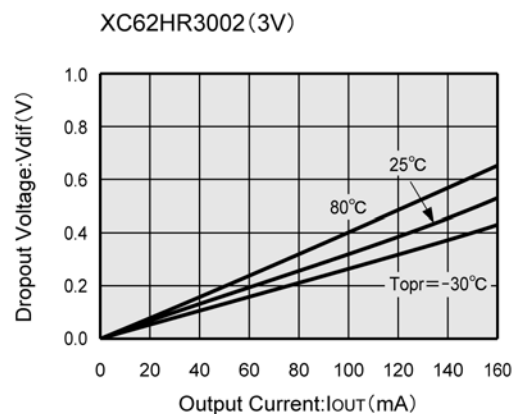
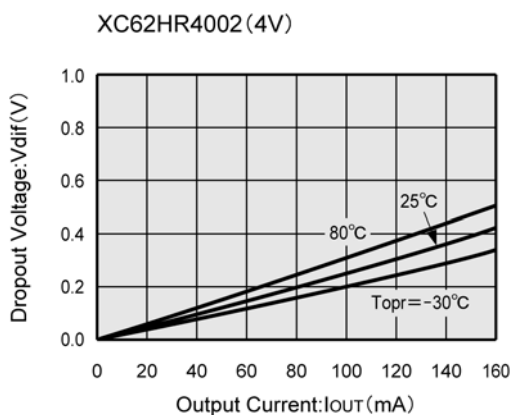
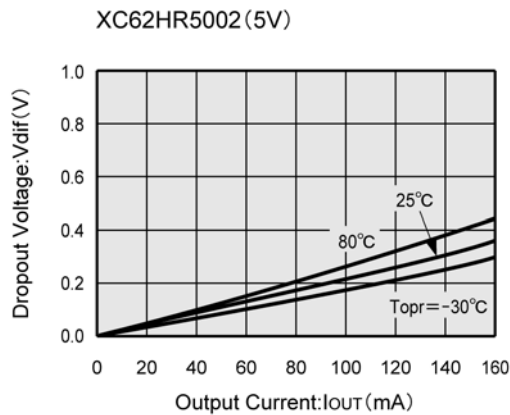

■ TYPICAL PERFORMANCE CHARACTERISTICS (Continued)

(4) CE Pin Threshold Voltage vs. Input Voltage

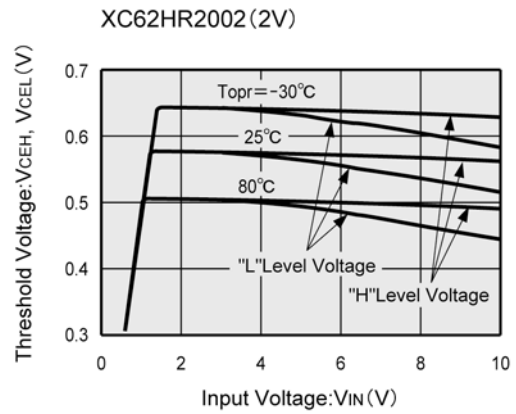
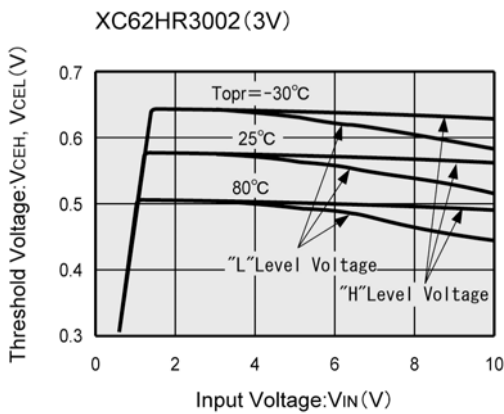
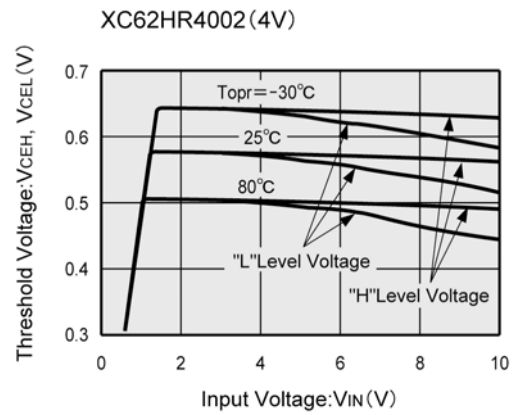
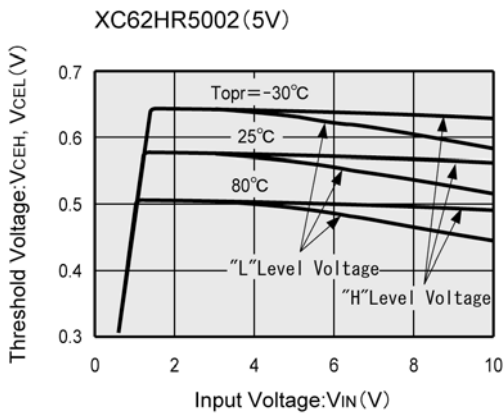

(5) Supply Current vs. Input Voltage

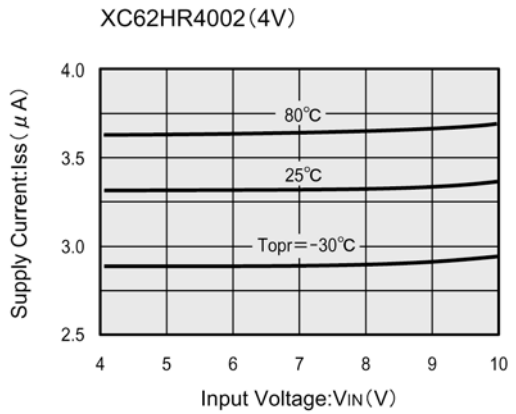
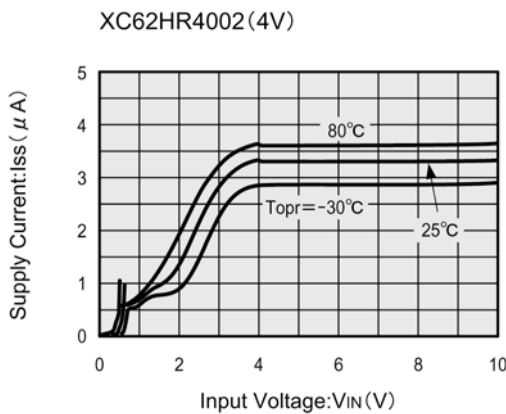
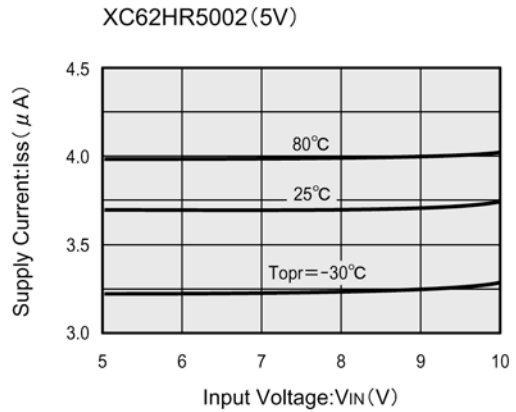
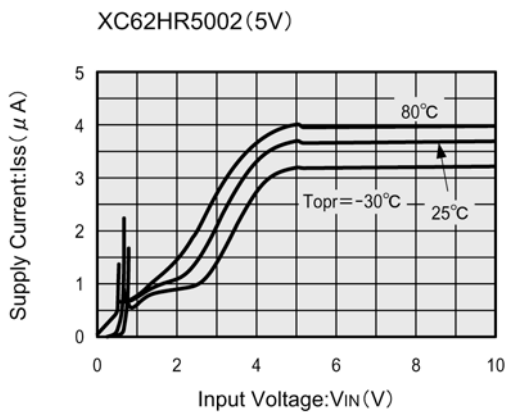

TYPICAL PERFORMANCE CHARACTERISTICS (Continued)

(5) Supply Current vs. Input Voltage (Continued)

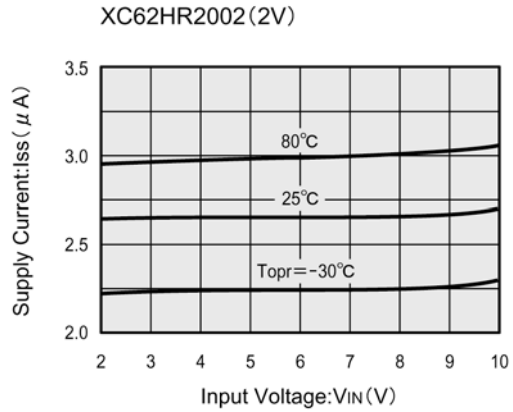
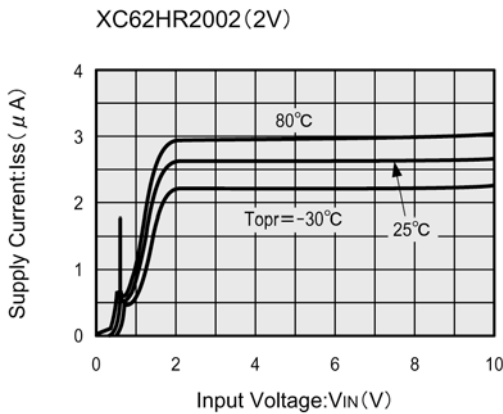
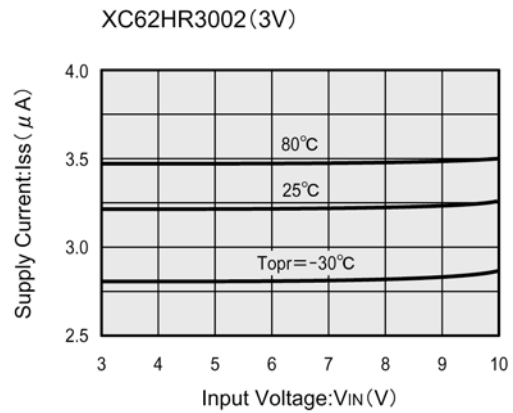
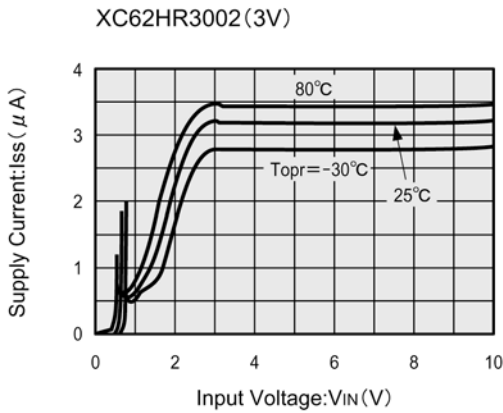

(6) Output Voltage vs. Ambient Temperature

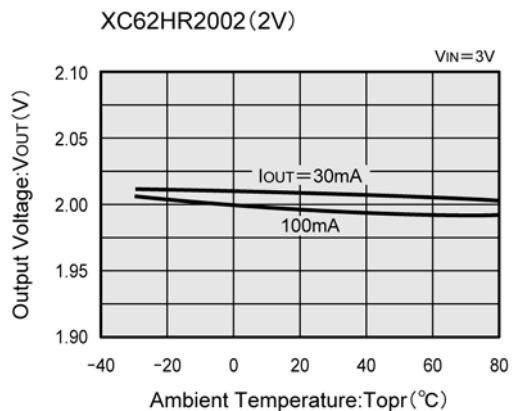
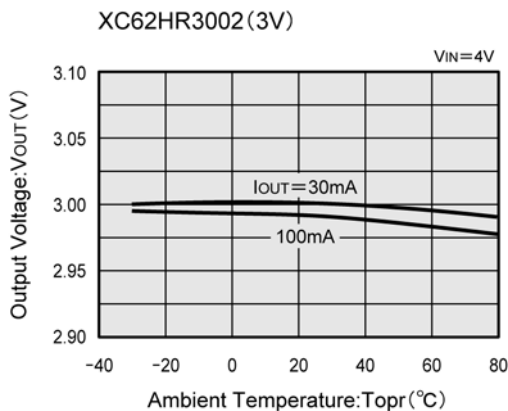
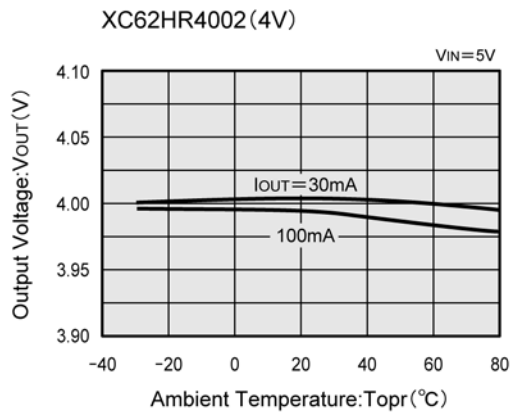
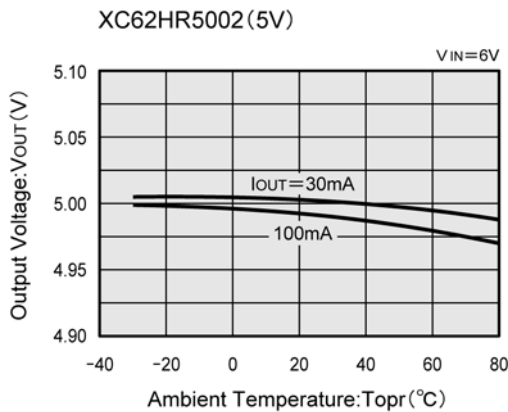

■ TYPICAL PERFORMANCE CHARACTERISTICS (Continued)

(7) Supply Current vs. Ambient Temperature

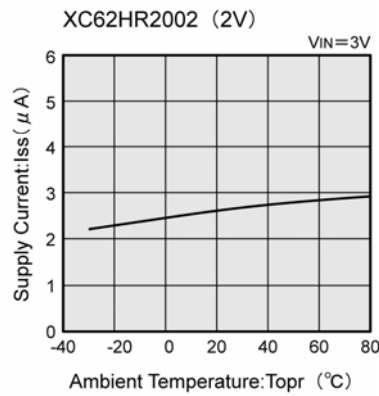
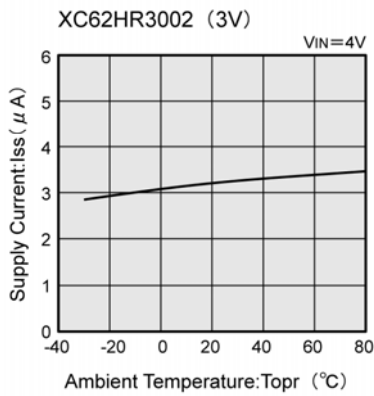
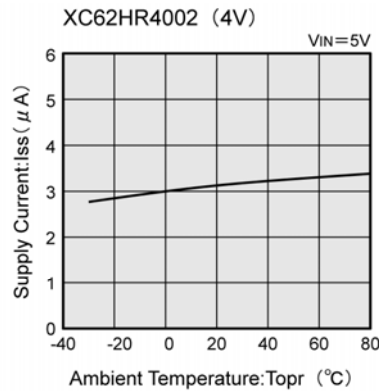
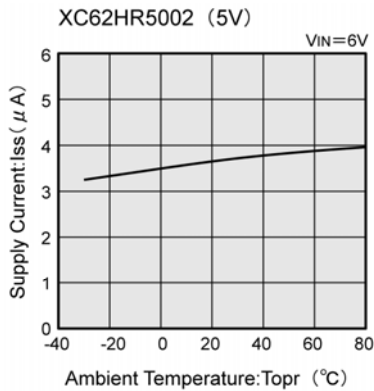

(8) Input Transient Response 1

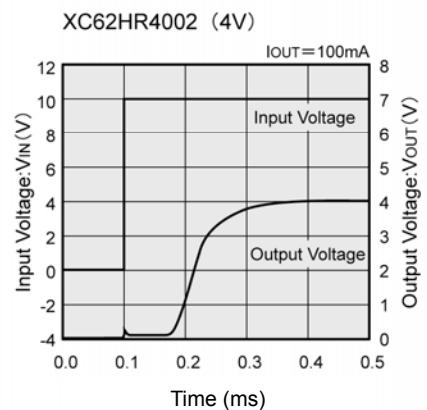
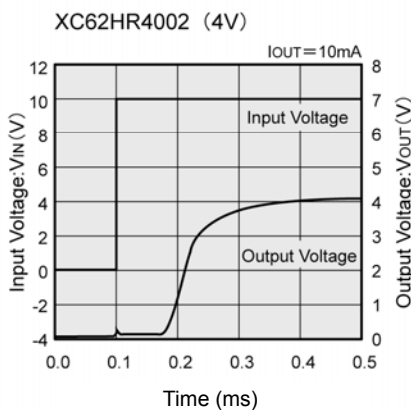
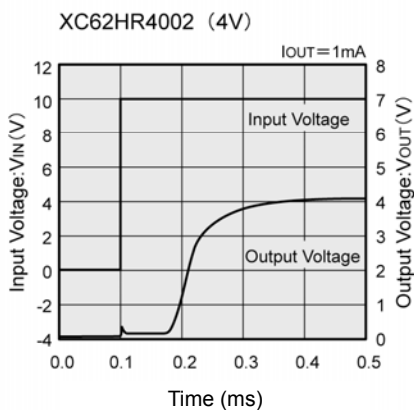
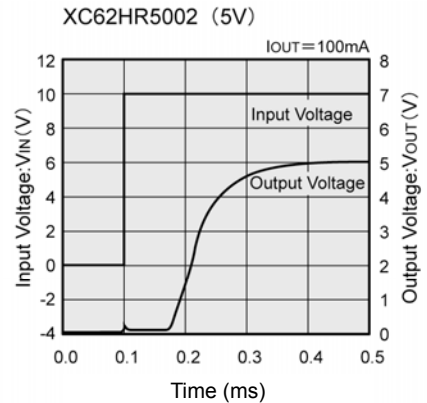
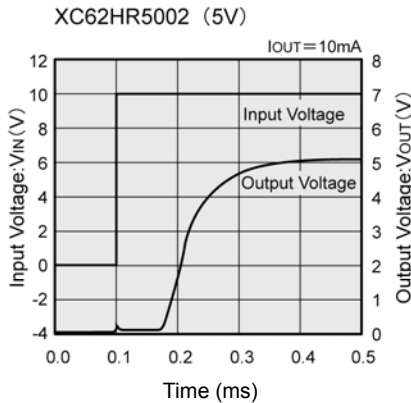
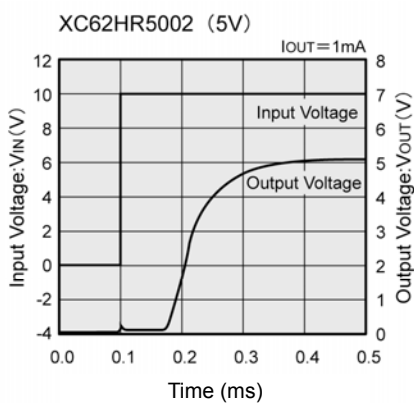

TYPICAL PERFORMANCE CHARACTERISTICS (Continued)

(8) Input Transient Response 1 (Continued)

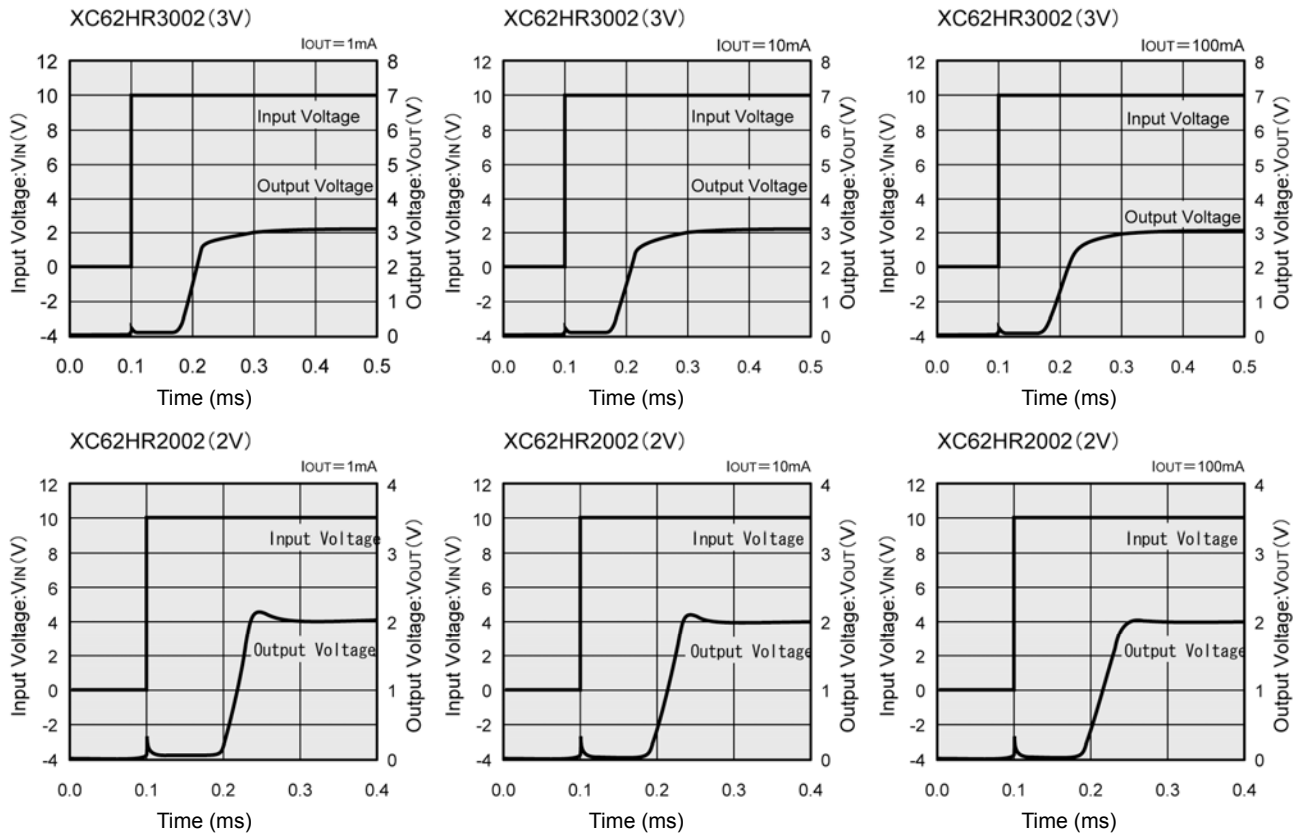

(9) Input Transient Response 2

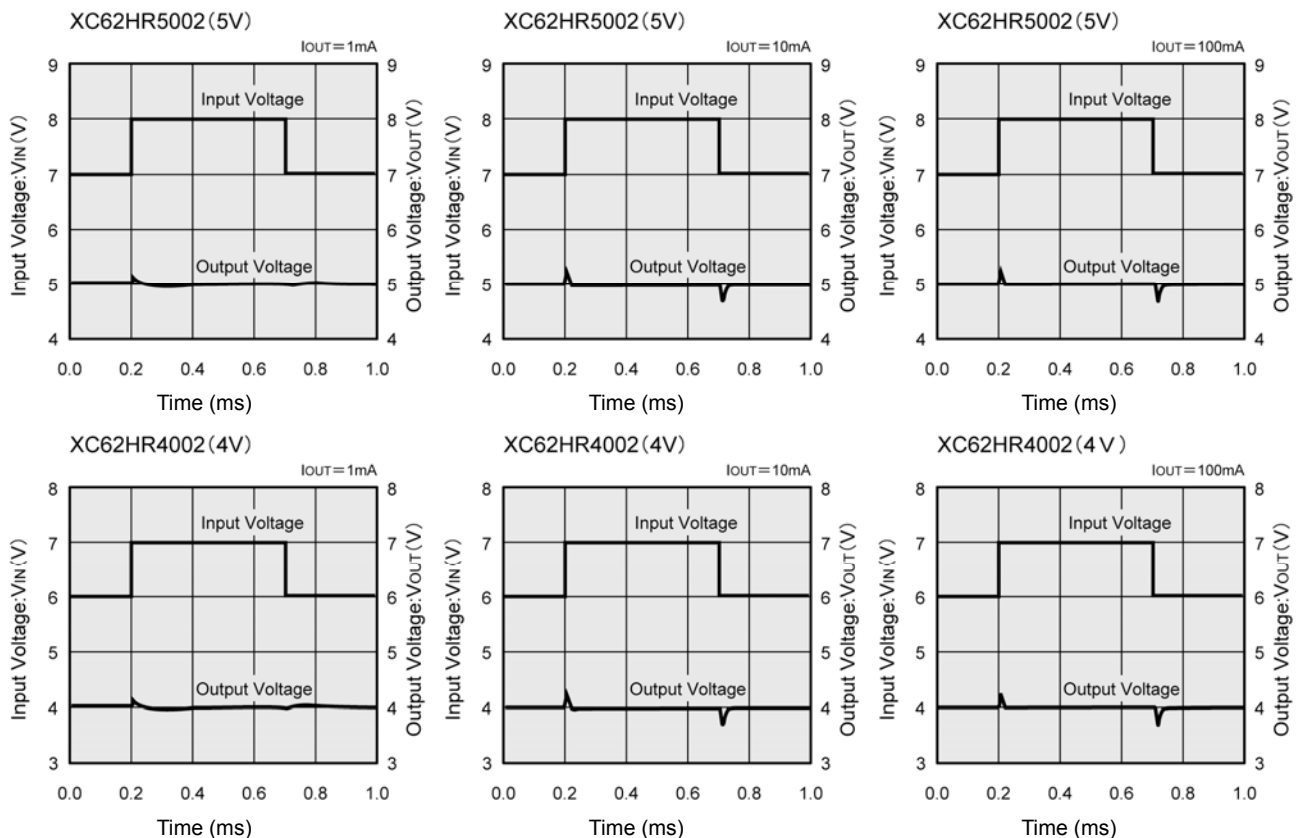

■ TYPICAL PERFORMANCE CHARACTERISTICS (Continued)

(9) Input Transient Response 2 (Continued)

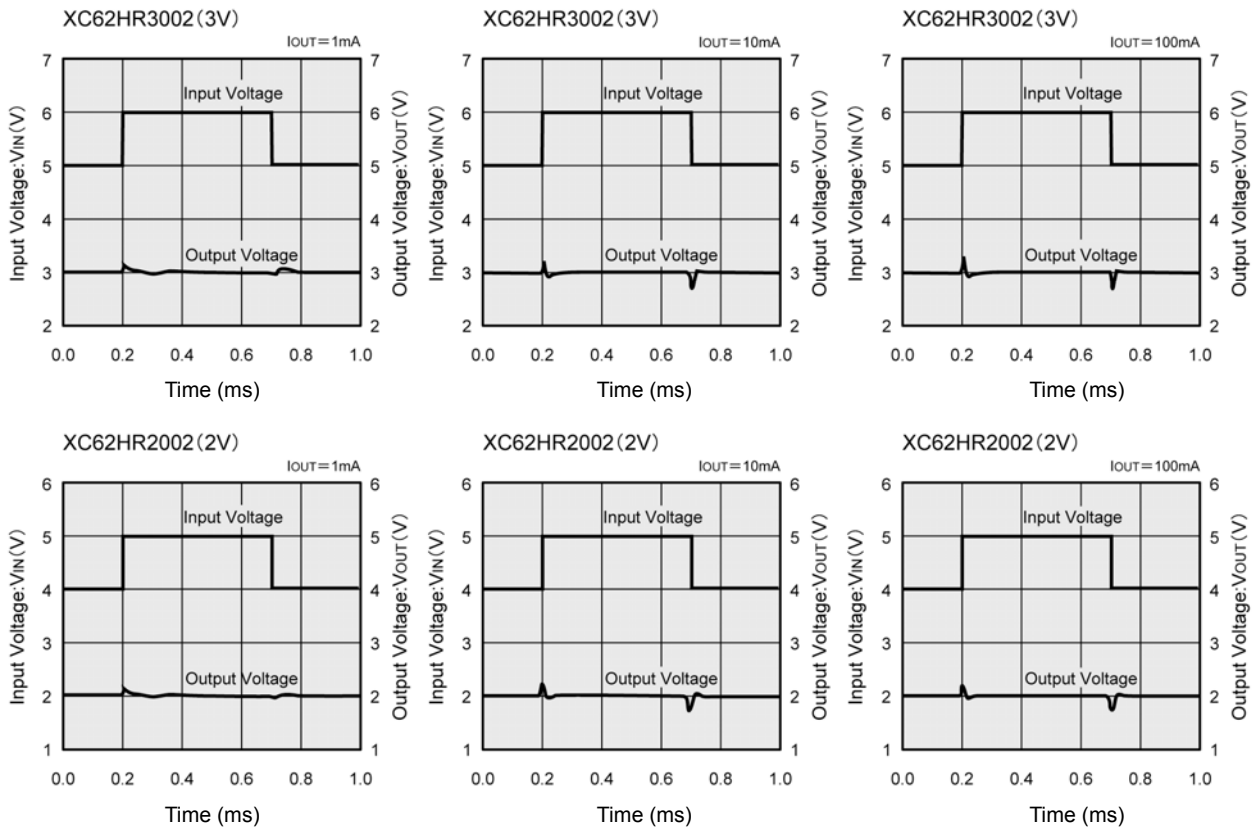

(10) Load Transient Response

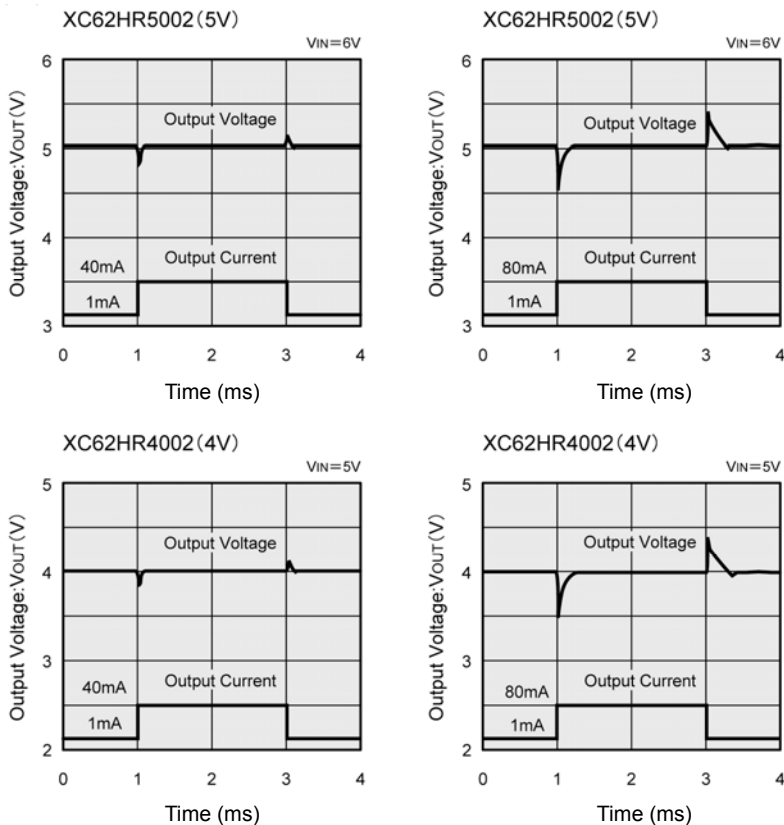

TYPICAL PERFORMANCE CHARACTERISTICS (Continued)

(10) Load Transient Response (Continued)

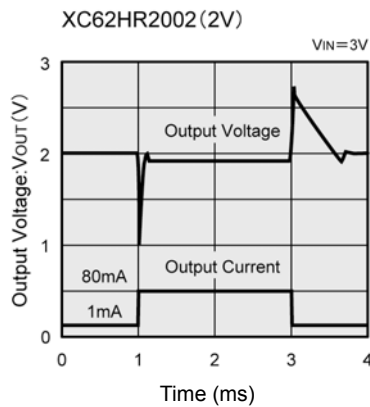
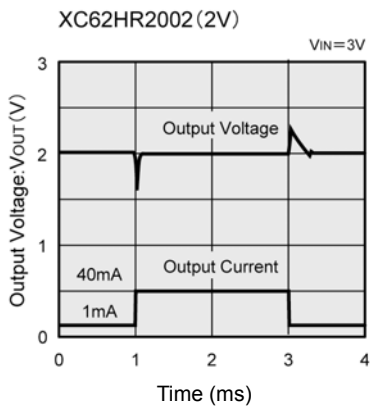
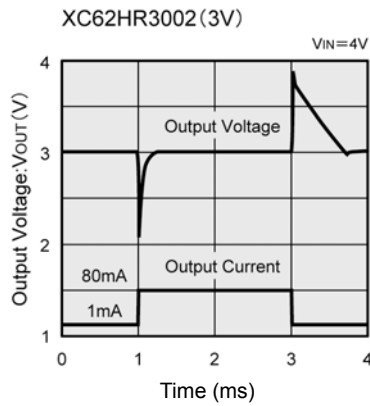
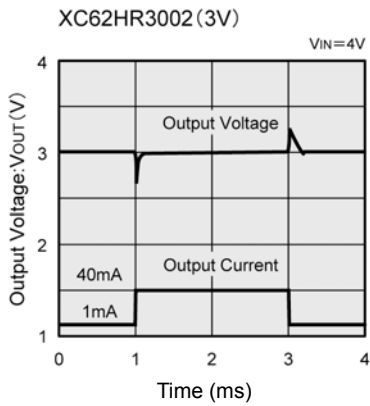

(11) CE Pin Transient Response

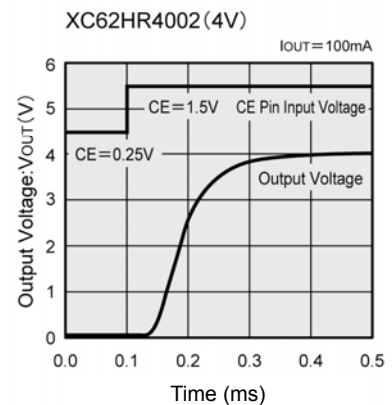
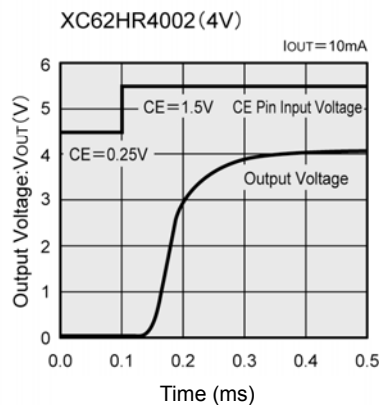
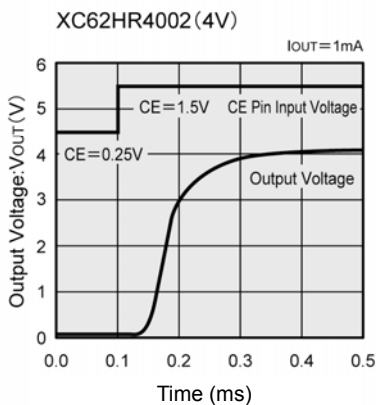
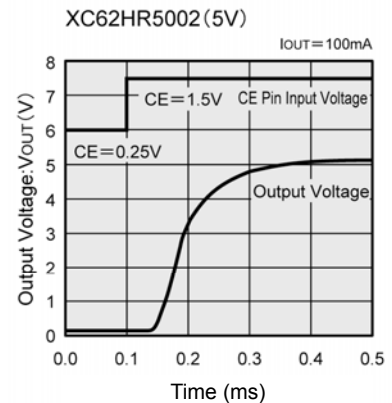
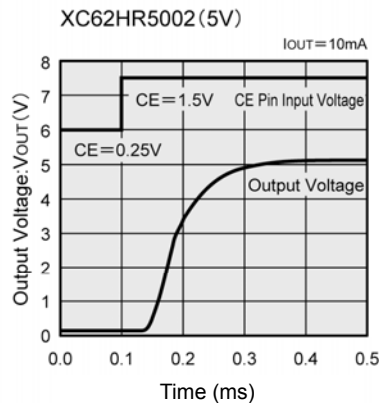
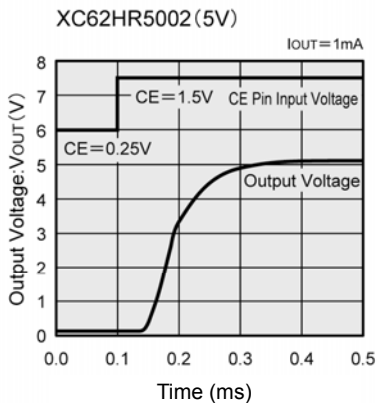

■ TYPICAL PERFORMANCE CHARACTERISTICS (Continued)

(11) CE Pin Transient Response (Continued)

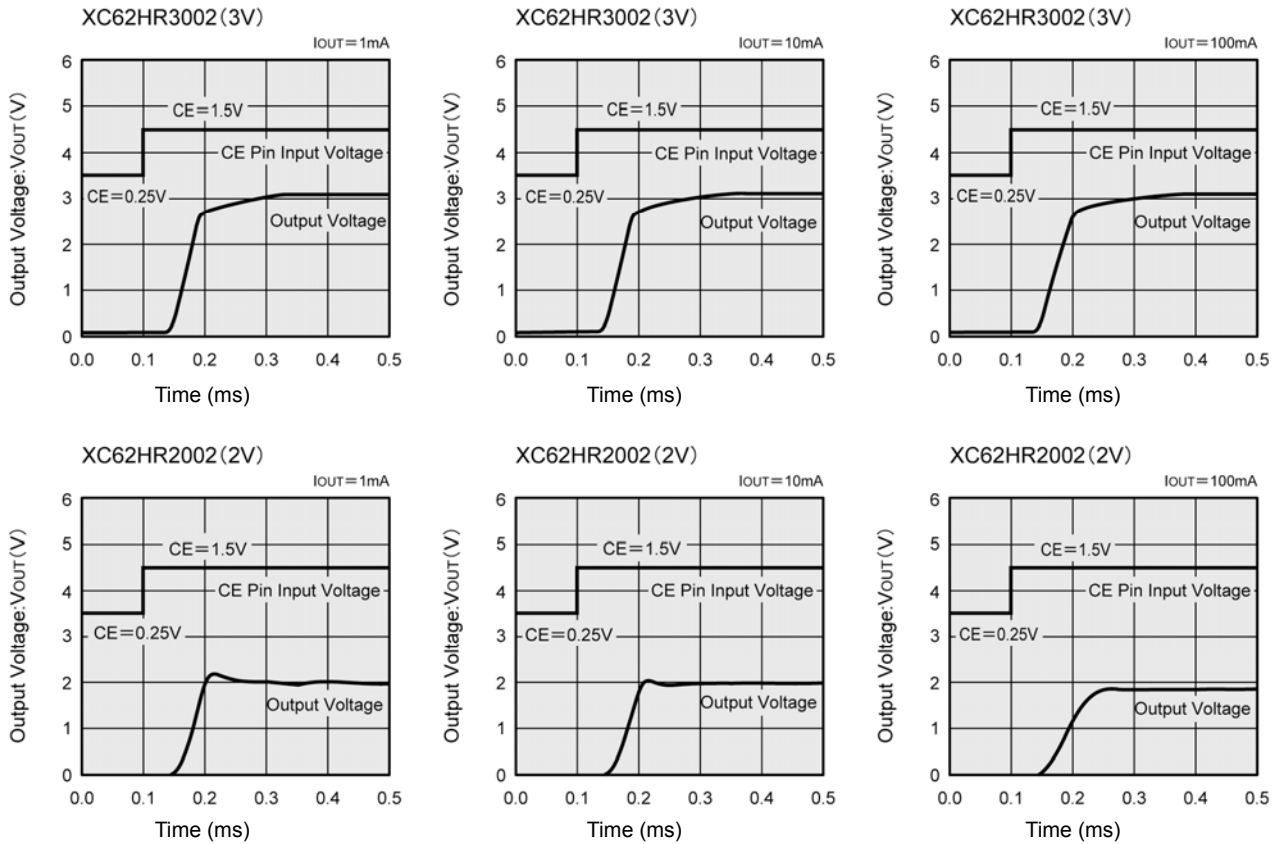

(12) Ripple Rejection Rate

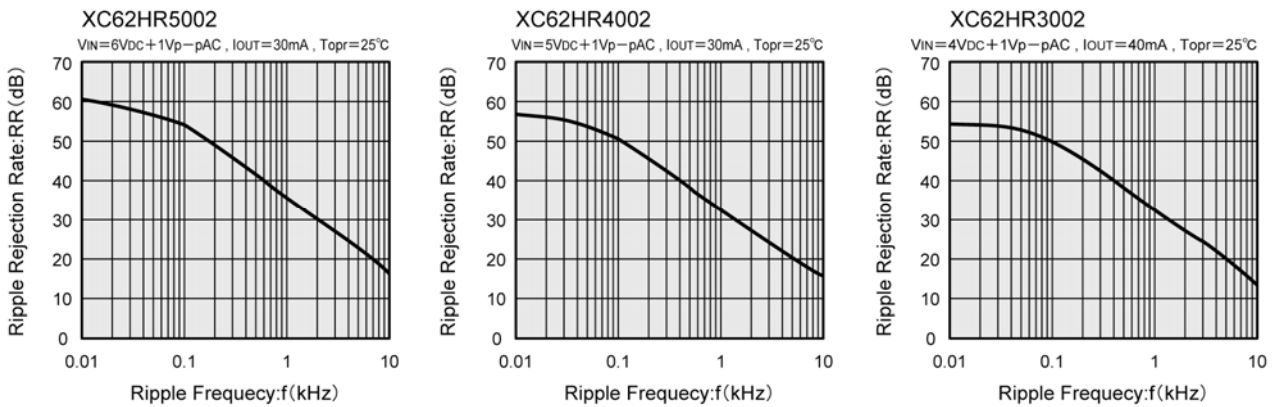

PACKAGING INFORMATION

● SOT-25

(unit : mm)

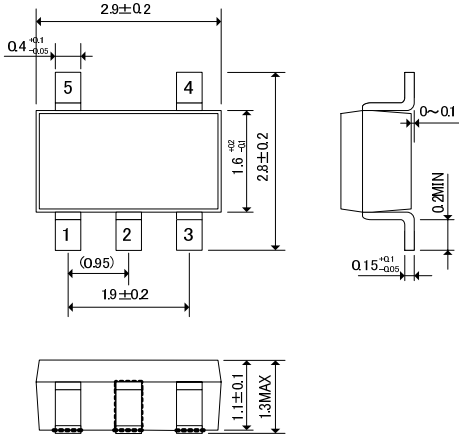

● SOT-89-5

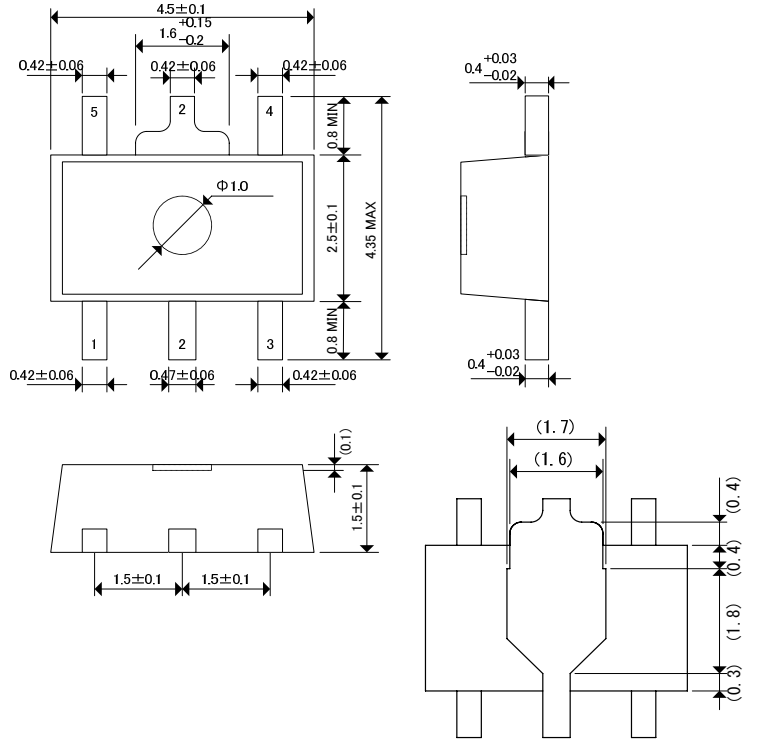

● USP-6B

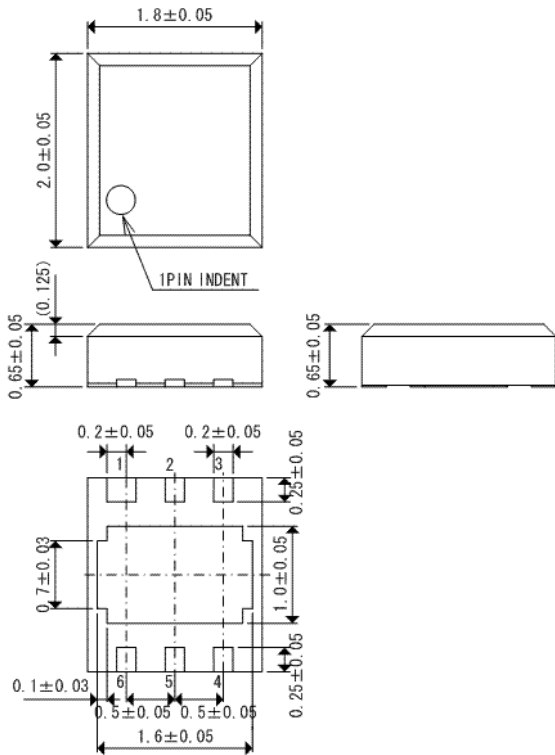

PACKAGING INFORMATION (Continued)

● USP-6B Reference Pattern Layout

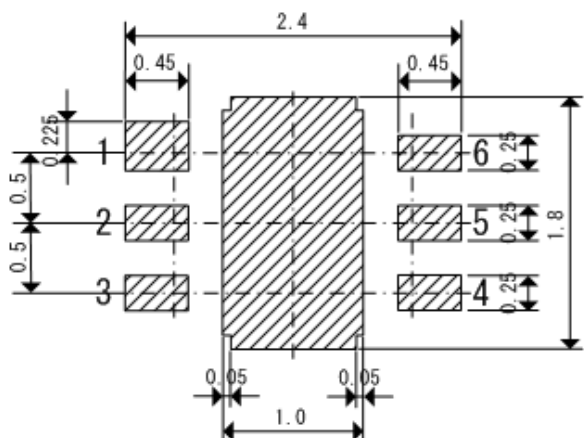

● USP-6B Reference metal mask design

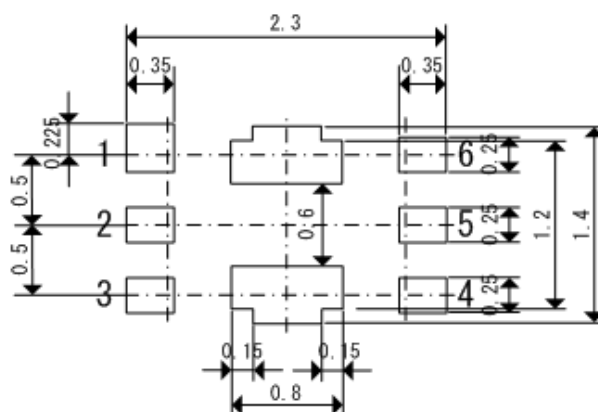

MARKING RULE

● SOT-25, SOT-89-5

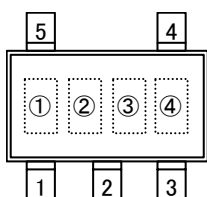

SOT-25
(TOP VIEW)

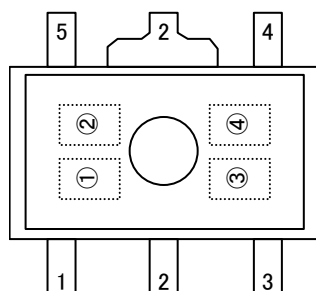

SOT-89-5
(TOP VIEW)

① represents integer of the output voltage

MARK	VOLTAGE (V)
0	0.②
1	1.②
2	2.②
3	3.②
4	4.②
5	5.②
6	6.②

② represents decimal number of the output voltage

MARK	VOLTAGE (V)
0	①.0
1	①.1
2	①.2
3	①.3
4	①.4
5	①.5
6	①.6
7	①.7
8	①.8
9	①.9

③ represents temperature characteristics

MARK
-

④ represents production lot number

0 to 9, A to Z repeated, reverse character 0 to 9, A to Z repeated
(G, I, J, O, Q, W excluded)

MARKING RULE

● USP-6B

① represents product series

MARK	PRODUCT SERIES
H	XC62HR**0*D*

② represents CE pin logic

MARK	LOGIC	PRODUCT SERIES
R	Positive	XC62HR**0*D*

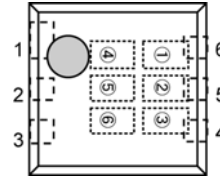

USP-6B
(TOP VIEW)

③④ represents output voltage

ex:

MARK		VOLTAGE(V)	PRODUCT SERIES
③	④		
3	3	3.3	XC62HR330*D*
5	0	5.0	XC62HR500*D*

⑤ represents temperature characteristics

MARK	TEMPERATURE CHARACTERISTICS	PRODUCT SERIES
0	TYP±100ppm	XC62HR**0***

⑥ represents production lot number

0 to 9, A to Z repeated (G, I, J, O, Q, W excluded)

Note: No character inversion used.

1. The products and product specifications contained herein are subject to change without notice to improve performance characteristics. Consult us, or our representatives before use, to confirm that the information in this datasheet is up to date.
2. We assume no responsibility for any infringement of patents, patent rights, or other rights arising from the use of any information and circuitry in this datasheet.
3. Please ensure suitable shipping controls (including fail-safe designs and aging protection) are in force for equipment employing products listed in this datasheet.
4. The products in this datasheet are not developed, designed, or approved for use with such equipment whose failure or malfunction can be reasonably expected to directly endanger the life of, or cause significant injury to, the user.
(e.g. Atomic energy; aerospace; transport; combustion and associated safety equipment thereof.)
5. Please use the products listed in this datasheet within the specified ranges.
Should you wish to use the products under conditions exceeding the specifications, please consult us or our representatives.
6. We assume no responsibility for damage or loss due to abnormal use.
7. All rights reserved. No part of this datasheet may be copied or reproduced without the prior permission of TOREX SEMICONDUCTOR LTD.

TOREX SEMICONDUCTOR LTD.

单击下面可查看定价，库存，交付和生命周期等信息

[>>Torex Semiconductor\(特瑞仕\)](#)