

TOSHIBA Bi-CMOS Integrated Circuit Silicon Monolithic

TB62802AFG

CCD Clock Drivers

The TB62802AFG is a clock distribution driver for CCD linear image sensors.

The IC can functionally drive the CCD input capacitance. It also supports inverted outputs, eliminating the need for cross point control.

The IC contains a 1-to-4 clock distribution driver and 4-bit buffer.

The suffix (G) appended to the part number represents a Lead (Pb) -Free product.

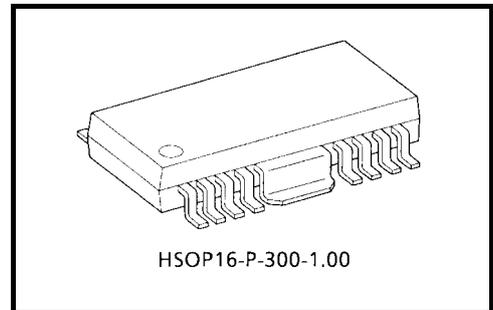

Weight: 0.5 g (typ.)

Features

- High drivability:
 - In the case of 4-bit distribution driver ,
 - Guaranteed driving 250 pF load capacitance @fclock = 25 MHz.
 - In the case of 2-bit distribution driver (ϕ only or $\bar{\phi}$ only),
 - Guaranteed driving 250 pF load capacitance @fclock = 35 MHz.
- Operating temperature range: Ta = 0°C to 60°C

Pin Connection (top view)

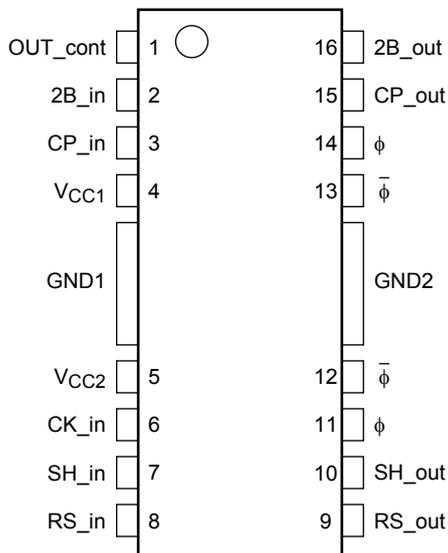

Logic Diagram

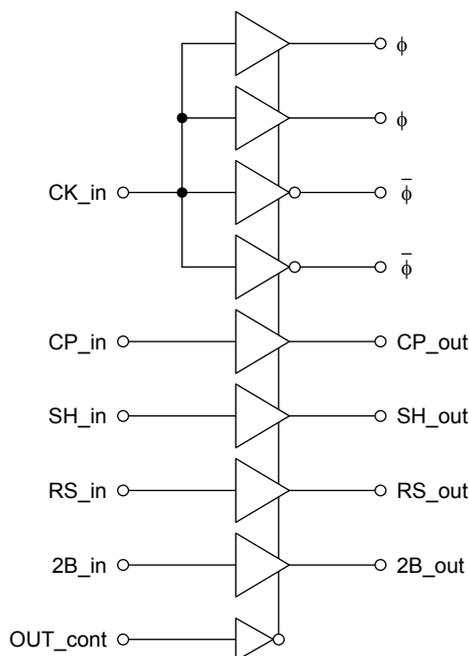

Pin Description

Pin No.	Pin Name	Functions	Remarks
1	OUT_cont	Output control pin	Internal pull down R=250 k ohm
2	2B_in	Light load drive input	Driver input for CCD last-stage clock
3	CP_in	Light load drive input	CCD clamp gate driver input
4	V _{CC1}	Light load power supply	—
—	GND1	Light load ground	—
5	V _{CC2}	Heavy load power supply	—
6	CK_in	Heavy load drive input	Driver input for CCD transfer clock
7	SH_in	Light load drive input	CCD shift gate driver input
8	RS_in	Light load drive input	CCD reset gate driver input
9	RS_out	Light load drive output (not inverted)	CCD reset gate driver output
10	SH_out	Light load drive output (not inverted)	CCD shift gate driver output
11	ϕ	Heavy load drive output (not inverted)	Driver output for CCD transfer clock
12	$\bar{\phi}$	Heavy load drive output (inverted)	Driver output for CCD transfer clock
—	GND2	Heavy load ground	—
13	$\bar{\phi}$	Heavy load drive output (inverted)	Driver output for CCD transfer clock
14	ϕ	Heavy load drive output (not inverted)	Driver output for CCD transfer clock
15	CP_out	Light load drive output (not inverted)	CCD clamp gate driver output
16	2B_out	Light load drive output (not inverted)	Driver output for CCD last-stage clock

Note1: The internal circuits for heavy load drive pins ϕ and $\bar{\phi}$ have the same configuration as those of light load drive pins RS_out, SH_out, CP_out and 2B_out. Thus, these internal circuits have the same characteristics.

Truth Table

Input				Output	
Pin Name	Logic	Pin Name	Logic	Pin Name	Logic
OUT_cont	L	CK_in	L	ϕ	L
				$\bar{\phi}$	H
			H	ϕ	H
				$\bar{\phi}$	L
		CP_in	L	CP_out	L
			H		H
		SH_in	L	SH_out	L
			H		H
		RS_in	L	RS_out	L
			H		H
		2B_in	L	2B_out	L
			H		H
	H	—	—	All Output	L

Absolute Maximum Ratings (Ta = 25°C)

Characteristic		Symbol	Rating	Unit
Power supply voltage		V _{CC}	-0.3 to 6.0	V
Input voltage		V _{IN}	-0.3 to V _{CC} + 0.3	V
Output voltage		V _O	-0.5 to V _{CC}	V
Output current excluding other than ϕ , $\bar{\phi}$ outputs	High level	I _{OH} (O)	-16.0	mA
	Low level	I _{OL} (O)	+16.0	mA
ϕ output current	High level	I _{OH} (ϕ)	-150	mA
	Low level	I _{OL} (ϕ)	150	mA
Storage temperature		T _{stg}	-40 to 150	°C
Junction temperature		T _j	150	°C
Thermal resistance	Chip to ambient air	θ_{ja}	83	°C/W

Note2: Output current is specified as follows: V_{OH} = 4.0 V, V_{OL} = 0.5 V.

Operating Conditions (Ta = 25°C)

Characteristic		Symbol	Min	Typ.	Max	Unit
Power supply voltage		V _{CC}	4.7	5.0	5.5	V
Input voltage		V _{IN}	0	—	V _{CC}	V
Output voltage		V _O	0	—	V _{CC}	V
Output current excluding ϕ , $\bar{\phi}$ outputs	High level	I _{OH} (O)	—	—	-8.0	mA
	Low level	I _{OL} (O)	—	—	8.0	mA
ϕ output current	High level	I _{OH} (ϕ)	—	—	-10.0	mA
	Low level	I _{OL} (ϕ)	—	—	10.0	mA
Thermal resistance (chip to case)		θ_{jc}	—	12	—	°C/W
Operating temperature		T _{opr}	0	25	60	°C
Input rise/fall time (Note3)		tri/tfi	—	2.5	5.0	ns

Note3: There is no hysteresis in the input block of this IC. Therefore attention should be given to the following:

A CMOS integrated circuit charges and discharges the capacitance load (internal equivalent capacitance) of the internal circuit while operating. The charged or discharged current flows in the package of the IC and inductance of transmission line, which causes inductive spike voltage to be generated.

When the spike voltage is generated in the reference GND, it affects the amplitude of an input signal. The amplitude seems to be fluctuating compared to when no spike voltage is generated in the reference GND. In this case, some induced spike waveforms exceed the input threshold level. For low-frequency inputs, the rate at which a spike exceeds the level increases, resulting in unstable output.

Therefore, do not apply input signals lower than 1 μ s. When designing a board, be sure to take transmission line inductance into consideration.

Electrical Characteristics

DC Characteristics (unless otherwise specified, $V_{CC} = 4.7$ to 5.5 V, $T_a = 0$ to 60°C)

Characteristic		Symbol	Test Circuit	Test Condition	V_{CC}	Min	Typ.	Max	Unit
Input voltage	High	V_{IH}	1		4.7	2.0	—	V_{CC}	V
	Low	V_{IL}			4.7	0	—	0.8	
Output voltage excluding ϕ , $\bar{\phi}$ outputs		$V_{OH} (O)$	2	$I_{OH} = -50 \mu\text{A}$	4.7	4.5	—	V_{CC}	V
				$I_{OH} = -8 \text{ mA}$	4.7	3.9	—	V_{CC}	
		$V_{OL} (O)$	4	$I_{OL} = 50 \mu\text{A}$	4.7	0	—	0.2	
				$I_{OL} = 8 \text{ mA}$	4.7	0	—	0.7	
ϕ output voltage		$V_{OH} (\phi/\bar{\phi})$	2,3	$I_{OH} = -10 \text{ mA}$	4.7	4.5	—	V_{CC}	V
				$I_{OH} = -30 \text{ mA}$	4.7	3.9	—	V_{CC}	
				$I_{OH} = -120 \text{ mA}$	4.7	3.0	—	V_{CC}	
		$V_{OL} (\phi/\bar{\phi})$	4,5	$I_{OL} = 50 \mu\text{A}$	4.7	0	—	0.3	
				$I_{OL} = 30 \text{ mA}$	4.7	0	—	0.5	
				$I_{OL} = 120 \text{ mA}$	4.7	0	—	2.0	
Input voltage		I_{IN1}	6	$V_{IN} (2,3,6,7,8\text{pin}) = V_{CC}$ or GND	5.5	-1.0	—	1.0	μA
		I_{IN2}		$V_{IN(1\text{pin})} = V_{CC}$ or GND	5.5	—	—	35	
Static current consumption		Total	7	For light load output, all bits are High. For heavy load output, 2 bits are High. 2 bits are Low.	5.5	—	—	15.0	mA
		Forced low for all bits	—	Out_cont = "H"	5.5	—	—	30.0	
		Each bit	8	One input : $V_{IN} = 0.5 \text{ V}$ or $V_{CC} - 2.1 \text{ V}$ Other inputs : $V_{IN} = V_{CC}$ or GND	—	—	—	1.5	
Output off mode supply voltage		V_{POR}	(Note 4)	Light load power supply (V_{CC1}) reference	—	—	3.0	—	V

Note4: Refer to the description of the P.O.R below.

Mode in Which Output Is Held at Low at Power-On (P.O.R: Power On Reset circuit)

To eliminate the unstable period for the internal logic, this IC incorporates a function for monitoring the light load power supply (V_{CC1}) at power-on to maintain the outputs at Low.

- At power-on, all output are held at Low until light load power supply (V_{CC1}) reaches the voltage level of 3 V.
- When the light load power supply (V_{CC1}) voltage is higher than 3 V (typ.), the internal logic operates according to input signals.
- For normal operation, be sure to use a power supply of 4.7 V or higher as guaranteed.

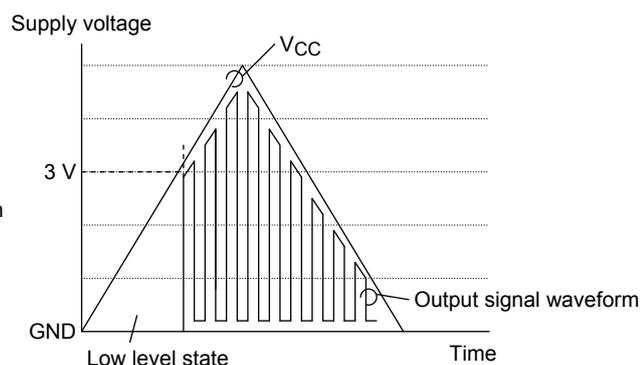
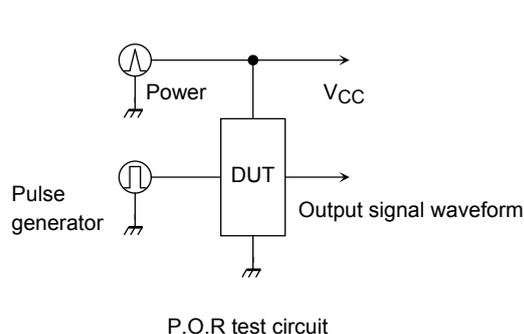

Refer to Subsection 10.
"Propagation Delay Time" in AC Parameters.

AC Characteristics (input transition rise or fall time: $t_r/t_f = 3.0$ ns)

Characteristic	Symbol	Test Condition	Ta = 25°C, VCC = 5.0 V			Ta = 0 to 60°C VCC = 4.7 to 5.5 V		Unit	Reference Measurement Diagram
			Min	Typ.	Max	Min	Max		
Propagation delay time	tpLH (φ)	CL = 250 pF	—	10.8	—	5	16	ns	Measurement diagram 1
	tpHL (φ)		—	9.8	—	5	16		
	tpLH (O)	CL = 20 pF	—	6.0	—	2	10		Measurement diagram 2
	tpHL (O)		—	6.2	—	2	12		
Output OFF time	tpCLH (φ)	CL = 250 pF	—	11.5	—	5	19	ns	Measurement diagram 3
	tpCHL (φ)		—	10.5	—	5	19		
	tpCLH (O)	CL = 20 pF	—	8.5	—	2	19		Measurement diagram 4
	tpCHL (O)		—	12.0	—	2	23		
Light load drive output skew	to (skw)	CL = 20 pF	0	—	2.0	0	2.0	ns	Measurement diagram 5
Heavy load drive output crosspoints	VT (crs)	CL = 100 to 250 pF	1.5	—	—	1.5	—	V	Measurement diagram 6
Equivalent internal capacitance (Note5)	CPD (φ)		—	32	—	—	—	pF	
	CPD (O)		—	9.4	—	—	—		

Note 5: CPD denotes "power dissipation capacitance". Dynamic power dissipation can be calculated using the CPD value.

$$Pd = \Sigma [CPD \times V_{CC}^2 \times Fin] + \Sigma (CL \times V_{CC}^2 \times Fout)$$

CL: Load capacitance per output

CPD: Power dissipation capacitance

Fin: Input clock frequency

Fout: Output clock frequency

For example:

For heavy load drive output, driving a load capacity of 250 pF at 25 MHz;

For light load drive output, driving a load capacity of 20 pF at 25 MHz.

Note 6: In practice, the frequencies of some shift gate control signals are lower than the transfer clock. Therefore the power dissipation during practical use is smaller than the calculated value below.

$$Pd = [32 \text{ pF} \times 5.0 \text{ V} \times 5.0 \text{ V} \times 25 \text{ MHz}] \times 4 \text{ bit} + (250 \text{ pF} \times 5.0 \text{ V} \times 5.0 \text{ V} \times 25 \text{ MHz}) \times 4 \text{ bit} \\ + [9.4 \text{ pF} \times 5.0 \text{ V} \times 5.0 \text{ V} \times 25 \text{ MHz}] \times 4 \text{ bit} + (20 \text{ pF} \times 5.0 \text{ V} \times 5.0 \text{ V} \times 25 \text{ MHz}) \times 4 \text{ bit} \\ \approx 778 \text{ mW}$$

The typical power dissipation is approximately 778 mW.

Notes on System Design

As shown above, the TB62802AFG consumes high current while operating. There is temporary flow of a current greater than the calculated value. To suppress bouncing from the power supply and GND, decoupling for the power supply is a vital necessity.

Below is an example of how the capacitance of a decoupling capacitor is calculated. Be sure to refer to this when designing a system.

The decoupling capacitor should be placed underneath the IC to reduce the high-frequency components.

Supply current variable: 350 mA (estimated variable in 1 bit)

Supply voltage variable: 0.3 V

Noise pulse width: 10 ns (time in which fluctuation occurs)

$$C = \Delta I_{CC} / (\Delta V / \Delta T) \\ = 350 \text{ mA} \times 4 \text{ bit} / (0.3 \text{ V} / 10 \text{ ns}) \\ \approx 47 \text{ nF} \\ \approx 0.047 \text{ } \mu\text{F} \text{ (when using a normal capacitor)}$$

To control the fluctuation in the low-frequency components, it is recommended that the power supply on the board be decoupled using a 10 μF to 50 μF capacitor.

Waveform Measuring Point

Propagation Delay Time Setting

- Input signal
- 2B_in
 - CK_in
 - SH_in
 - RS_in
 - CP_in
 - out_cont=L

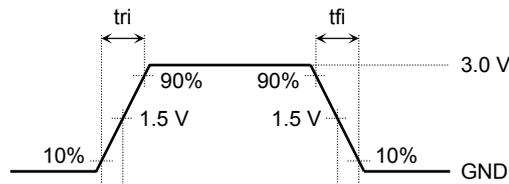

Measurement Diagram 1

- ϕ Output signal

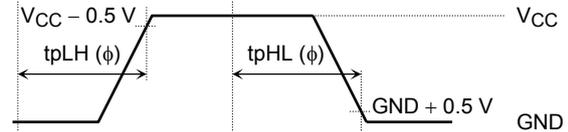

- $\bar{\phi}$ Output signal

Measurement Diagram 2

- 2B_out
- CK_out
- SH_out
- RS_out
- CP_out

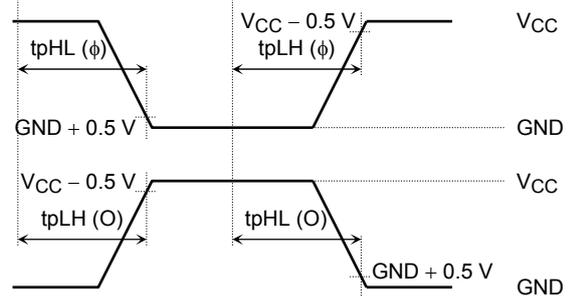

- Input signal
- 2B_in=CK_in=SH_in=RS_in=CP_in=H

- out_cont

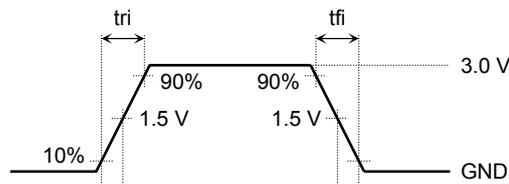

Measurement Diagram 3

- ϕ Output signal

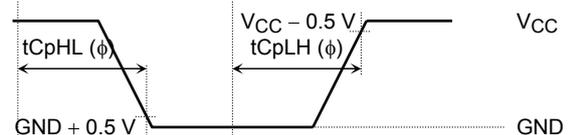

Measurement Diagram 4

- 2B_out
- CK_out
- SH_out
- RS_out
- CP_out

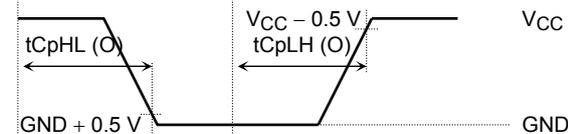

Measurement Diagram 5

- 2B_out
- CK_out
- SH_out
- RS_out
- CP_out

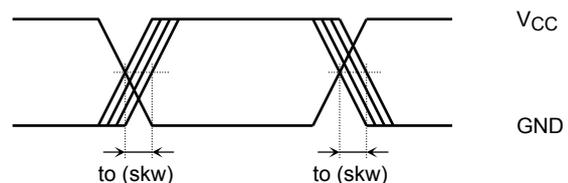

Output Waveform Crosspoint/Level Setting

Measurement Diagram 6

- ϕ Output signal
- $\bar{\phi}$ Output signal

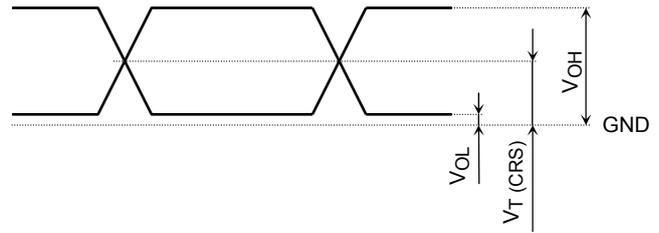

Reference Characteristics

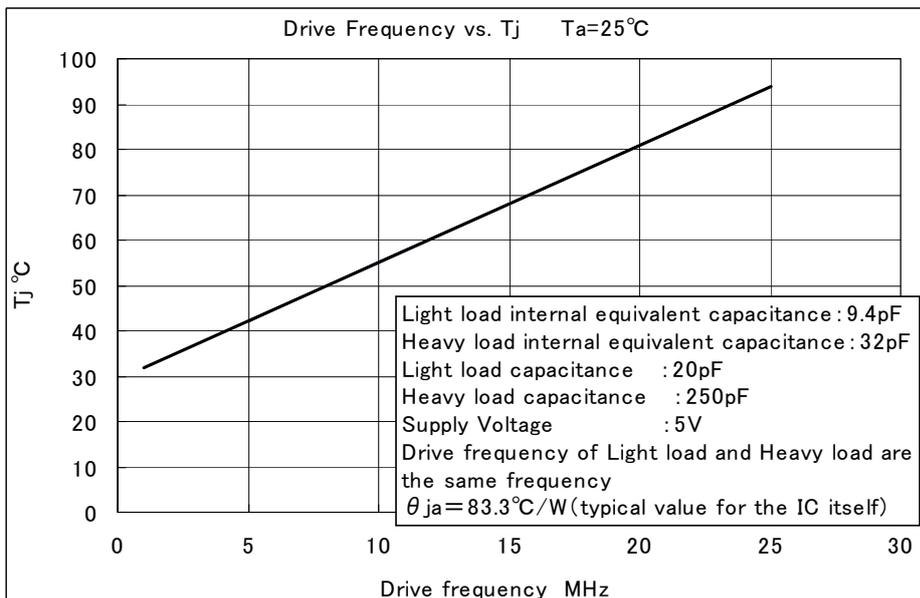
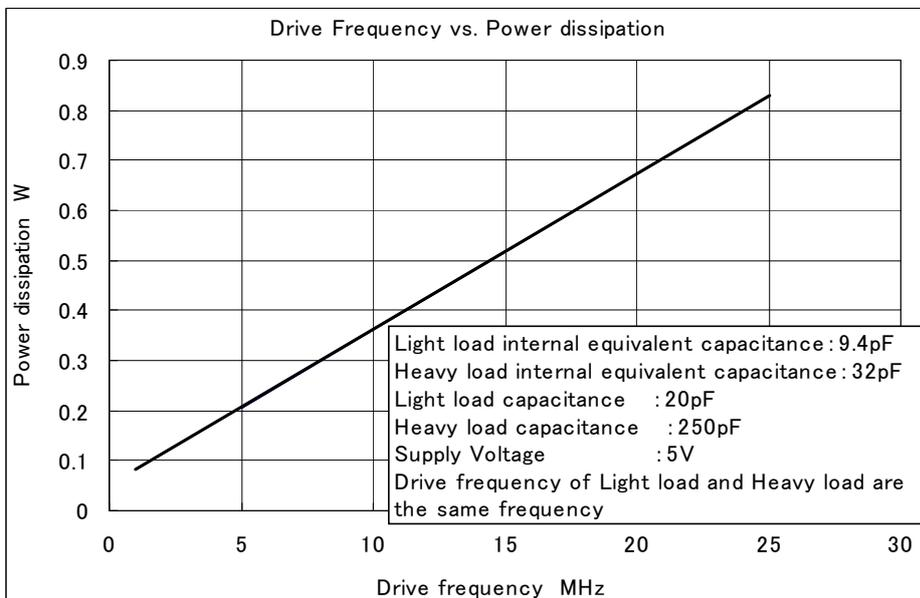
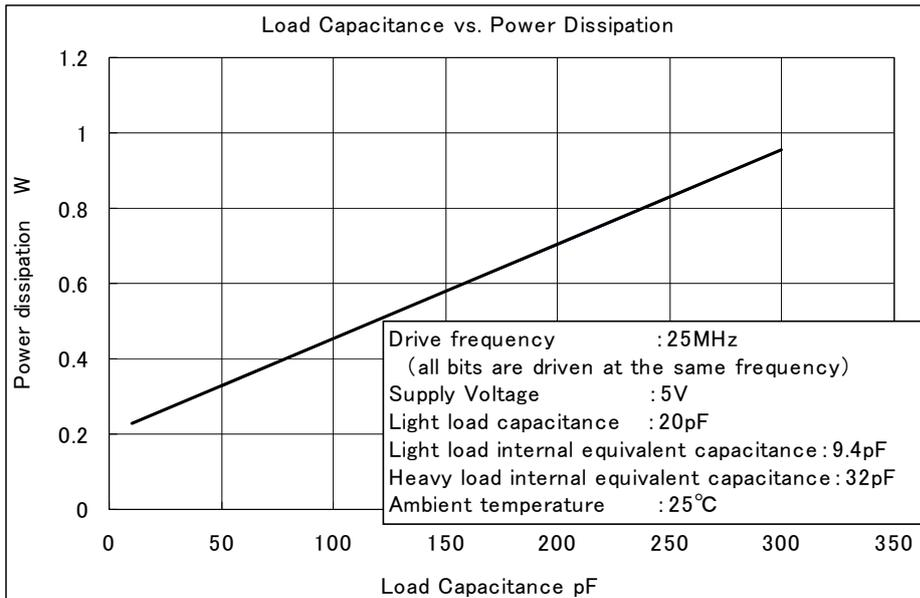

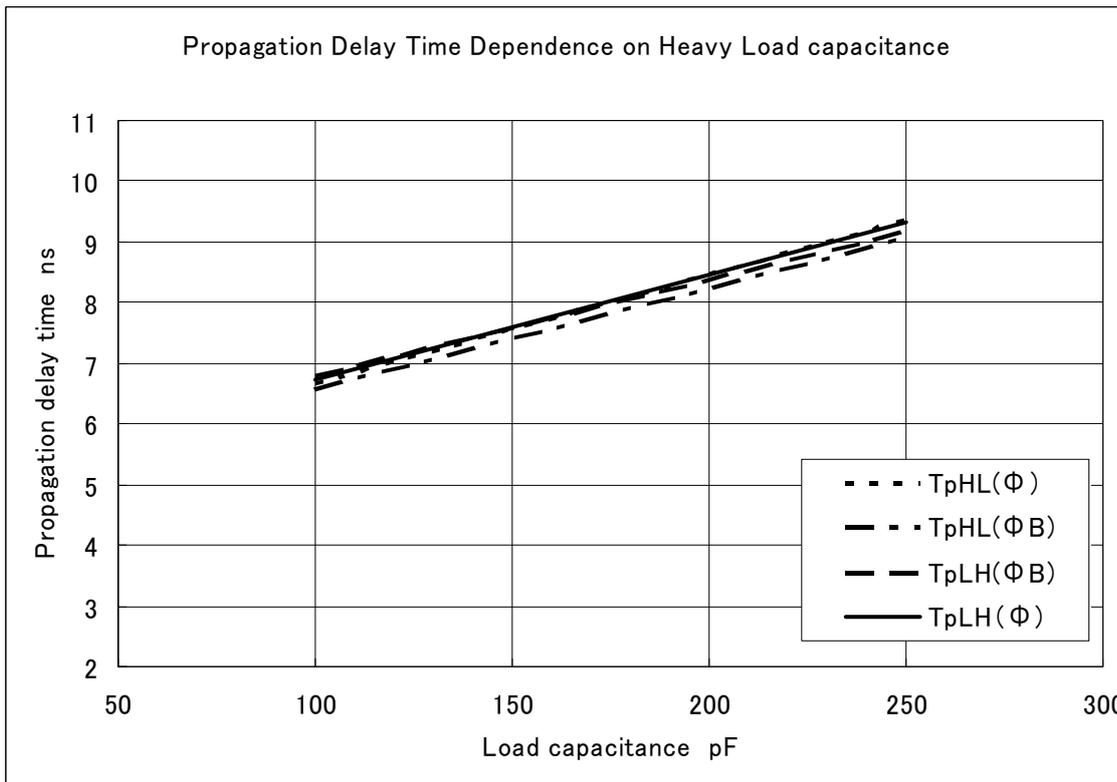
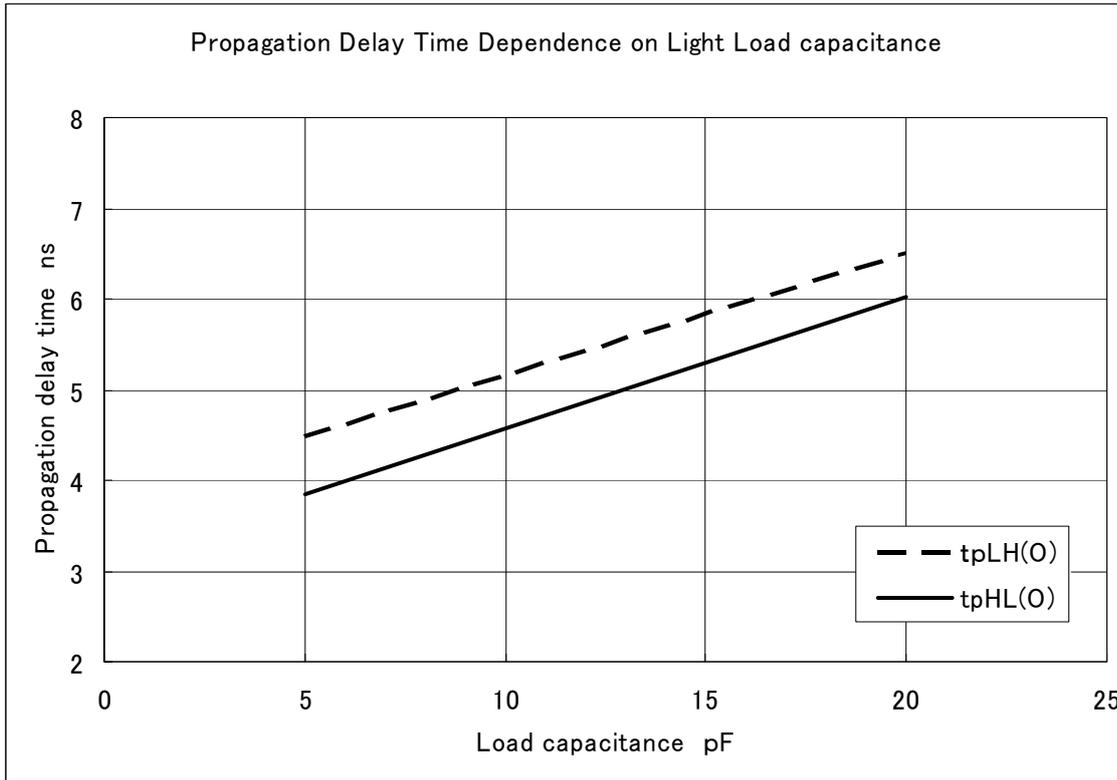

Test Circuit

DC Parameters

Pins marked with an asterisk (◆) are test pins. Be sure to ground those input pins that are not used as test pins so that the logic is determined. Unless otherwise specified, bits of the same type are measured in the same way.

1. V_{IH}/V_{IL}

(1) Light load drive bits

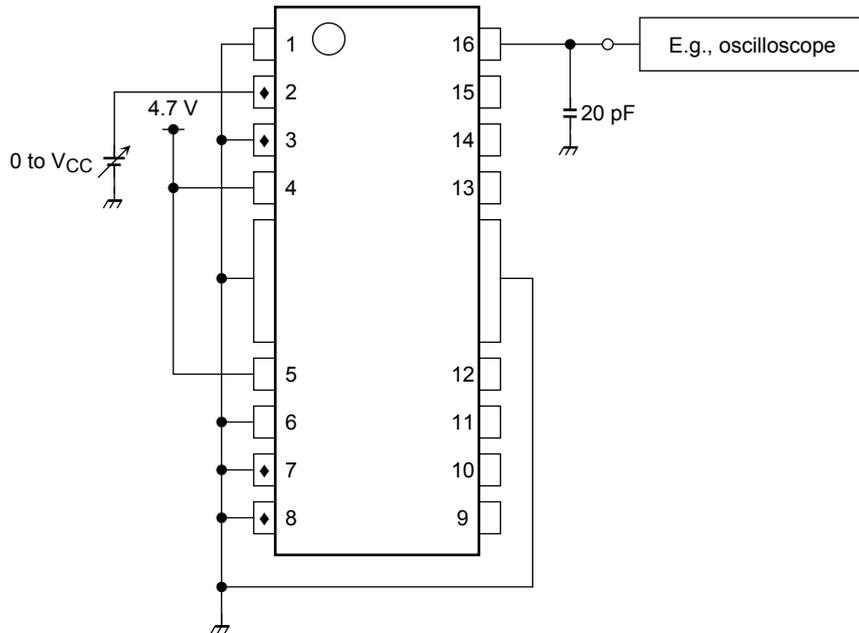

Note 7: When measuring input pins, connect to GND those input pins that are not being measured.

(2) Heavy load drive bits

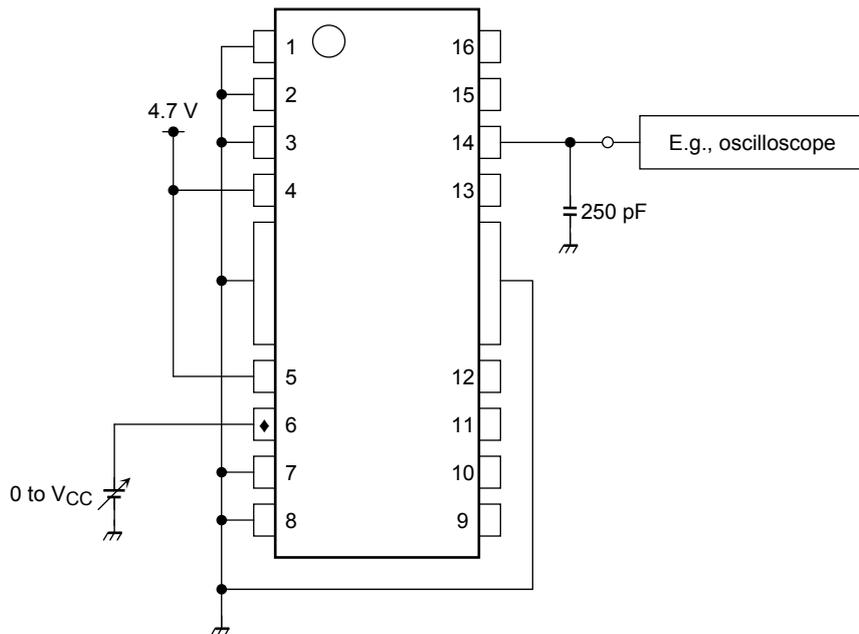

Note 8: Connect to GND those input pins that are not being measured.

2. $V_{OH} (O/\phi)$

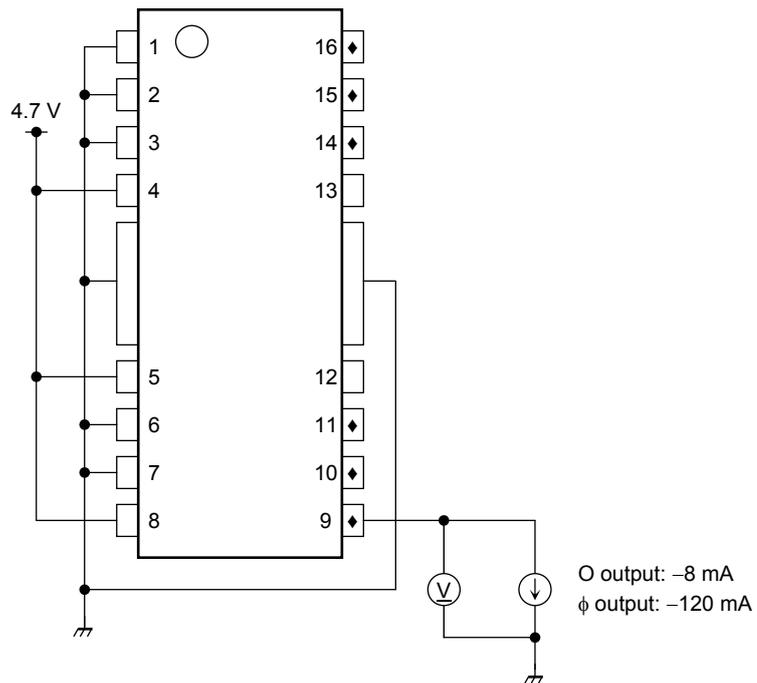

Note 9: Connect to GND those input pins that are not being measured.

3. $V_{OH}(\bar{\phi})$

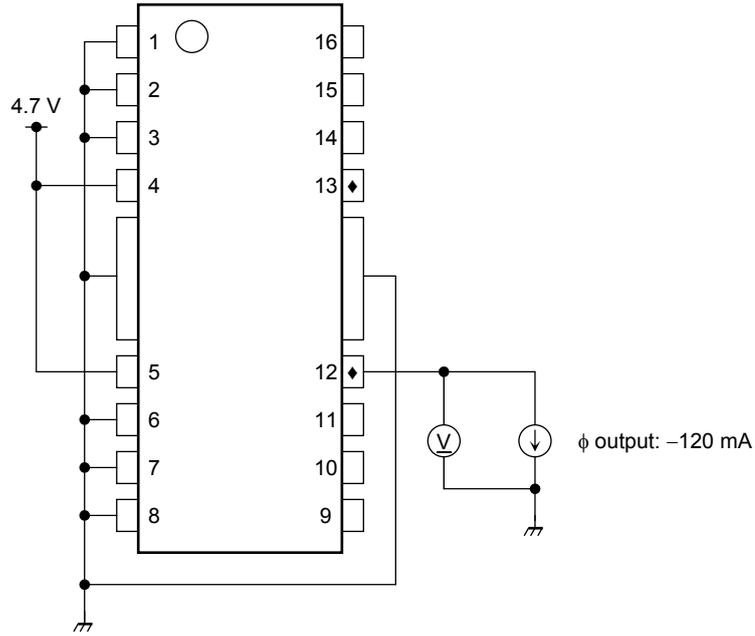

Note 10: Connect to GND those input pins that are not being measured.

4. $V_{OL}(O/\phi)$

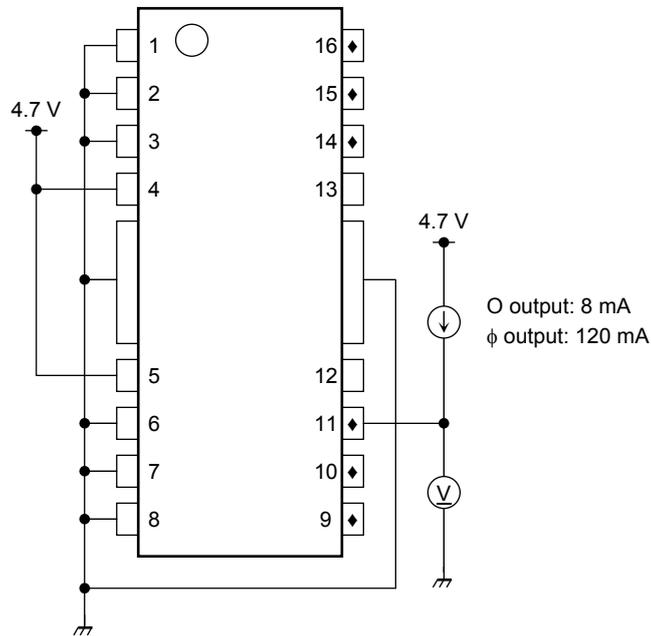

Note 11: Connect to GND those input pins that are not being measured.

5. $V_{OL}(\phi)$

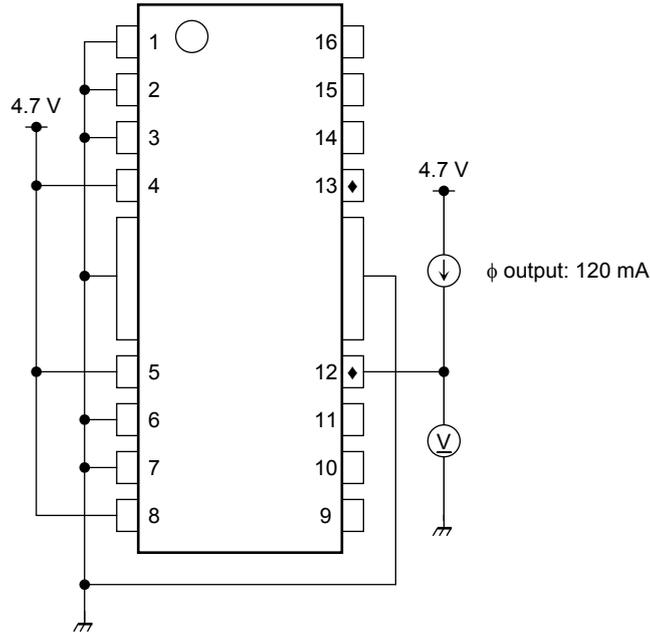

Note12: Connect to GND those input pins that are not being measured.

6. I_{IN}

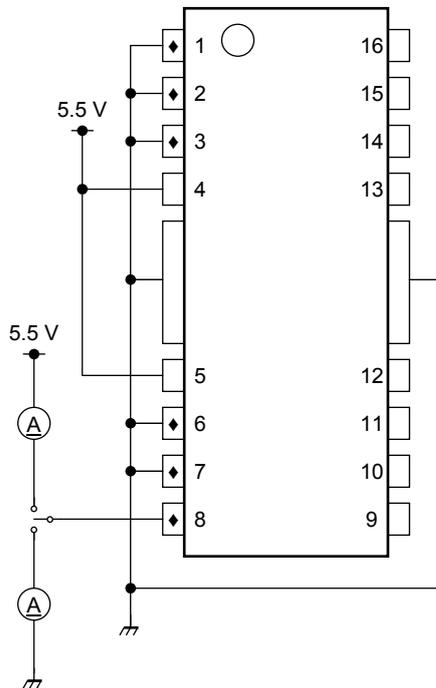

Note13: Connect to GND those input pins that are not being measured.

7. I_{cc}

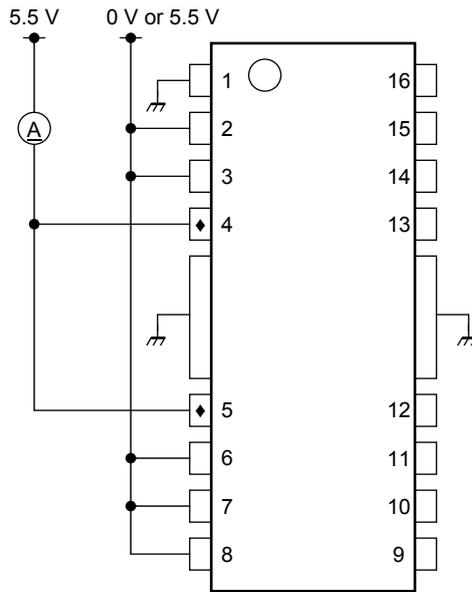

Note 14: The input logic of the heavy load drive clock input pin (pin 6) is the same for HIGH or LOW.

8. ΔI_{cc}

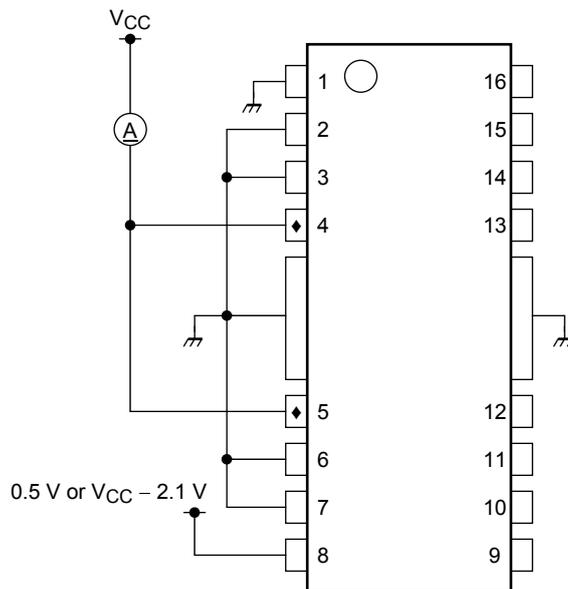

Note 15: When measuring input pins, connect to GND (or to the power supply) those input pins that are not being measured.

AC Parameters

Pins marked with an asterisk (*) are test pins. Ground those input pins that are not being used as test pins so that the logic is determined. Unless otherwise specified, bits of the same type are measured in the same way.

9. Propagation Delay Time

- (1) Light load drive bits

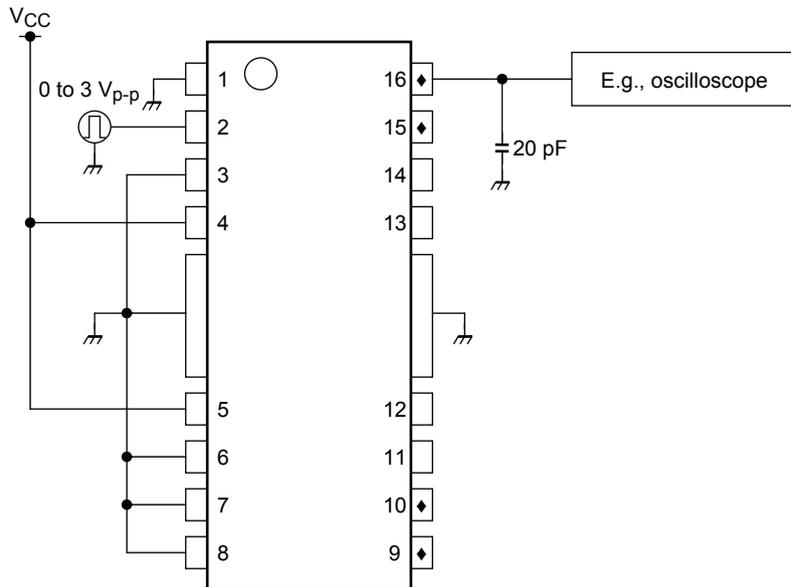

- (2) Heavy load drive bits

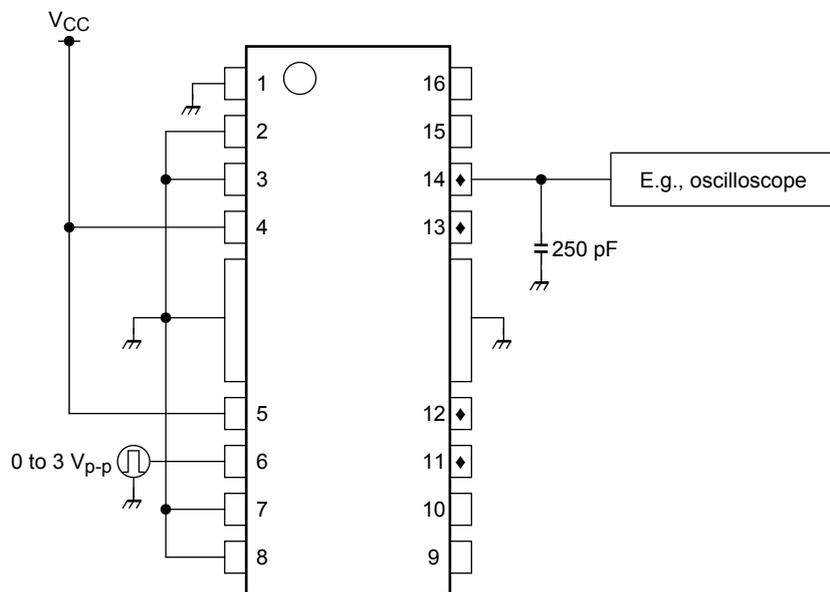

Package Dimensions

HSOP16-P-300-1.00

Unit : mm

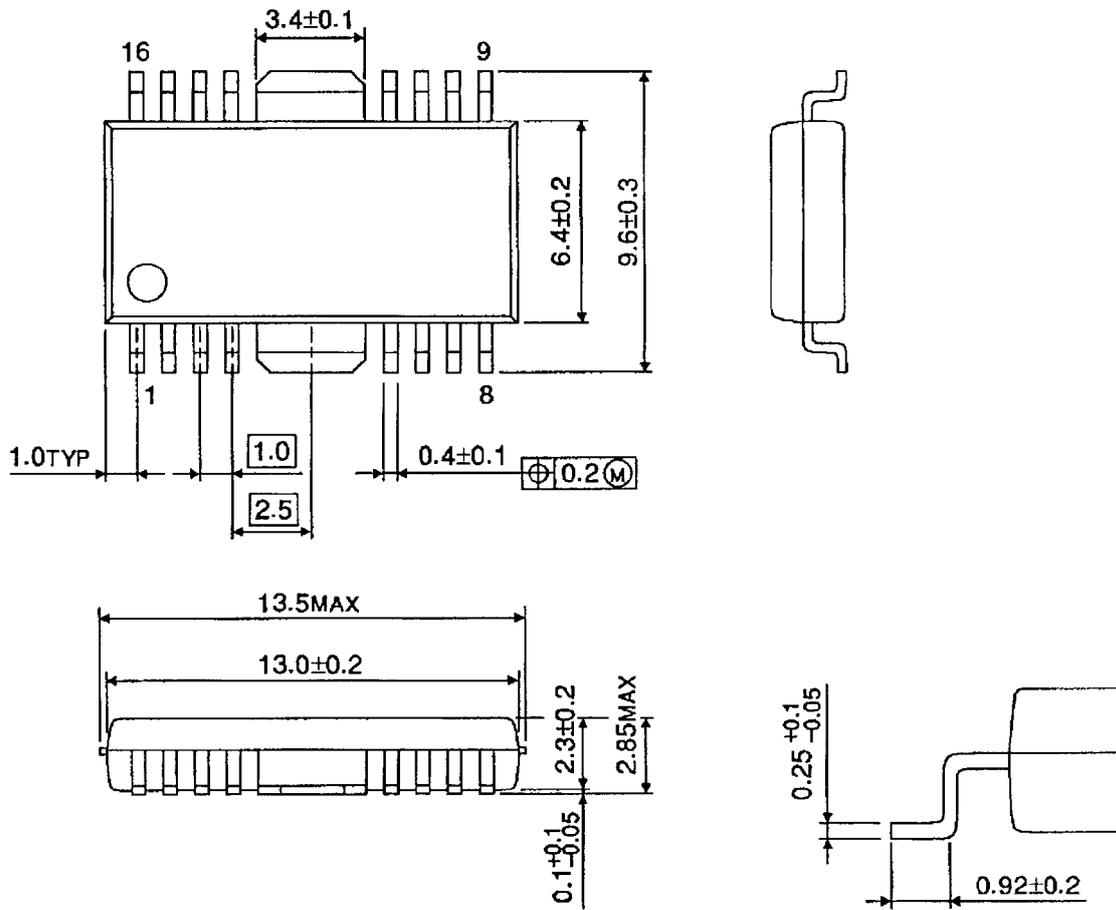

Weight: 0.5 g (typ.)

Notes on Contents

1. Block Diagrams

Some of the functional blocks, circuits, or constants in the block diagram may be omitted or simplified for explanatory purposes.

2. Equivalent Circuits

The equivalent circuit diagrams may be simplified or some parts of them may be omitted for explanatory purposes.

3. Timing Charts

Timing charts may be simplified for explanatory purposes.

4. Application Circuits

The application circuits shown in this document are provided for reference purposes only.

Thorough evaluation is required, especially at the mass production design stage.

Toshiba does not grant any license to any industrial property rights by providing these examples of application circuits.

5. Test Circuits

Components in the test circuits are used only to obtain and confirm the device characteristics. These components and circuits are not guaranteed to prevent malfunction or failure from occurring in the application equipment.

IC Usage Considerations

Notes on Handling of ICs

- (1) The absolute maximum ratings of a semiconductor device are a set of ratings that must not be exceeded, even for a moment. Do not exceed any of these ratings.
Exceeding the rating(s) may cause the device breakdown, damage or deterioration, and may result in injury by explosion or combustion.
- (2) Use an appropriate power supply fuse to ensure that a large current does not continuously flow in case of over current and/or IC failure. The IC will fully break down when used under conditions that exceed its absolute maximum ratings, when the wiring is routed improperly or when an abnormal pulse noise occurs from the wiring or load, causing a large current to continuously flow and the breakdown can lead smoke or ignition. To minimize the effects of the flow of a large current in case of breakdown, appropriate settings, such as fuse capacity, fusing time and insertion circuit location, are required.
- (3) If your design includes an inductive load such as a motor coil, incorporate a protection circuit into the design to prevent device malfunction or breakdown caused by the current resulting from the inrush current at power ON or the negative current resulting from the back electromotive force at power OFF. IC breakdown may cause injury, smoke or ignition.
Use a stable power supply with ICs with built-in protection functions. If the power supply is unstable, the protection function may not operate, causing IC breakdown. IC breakdown may cause injury, smoke or ignition.
- (4) Do not insert devices in the wrong orientation or incorrectly.
Make sure that the positive and negative terminals of power supplies are connected properly. Otherwise, the current or power consumption may exceed the absolute maximum rating, and exceeding the rating(s) may cause the device breakdown, damage or deterioration, and may result in injury by explosion or combustion.
In addition, do not use any device that is applied the current with inserting in the wrong orientation or incorrectly even just one time.

- (5) Carefully select external components (such as inputs and negative feedback capacitors) and load components (such as speakers), for example, power amp and regulator.
- If there is a large amount of leakage current such as input or negative feedback condenser, the IC output DC voltage will increase. If this output voltage is connected to a speaker with low input withstand voltage, over current or IC failure can cause smoke or ignition. (The over current can cause smoke or ignition from the IC itself.) In particular, please pay attention when using a Bridge Tied Load (BTL) connection type IC that inputs output DC voltage to a speaker directly.

Points to Remember on Handling of ICs

- (1) Heat Radiation Design
- In using an IC with large current flow such as power amp, regulator or driver, please design the device so that heat is appropriately radiated, not to exceed the specified junction temperature (T_j) at any time and condition. These ICs generate heat even during normal use. An inadequate IC heat radiation design can lead to decrease in IC life, deterioration of IC characteristics or IC breakdown. In addition, please design the device taking into consideration the effect of IC heat radiation with peripheral components.
- (2) Back-EMF
- When a motor rotates in the reverse direction, stops or slows down abruptly, a current flows back to the motor's power supply due to the effect of back-EMF. If the current sink capability of the power supply is small, the device's motor power supply and output pins might be exposed to conditions beyond absolute maximum ratings. To avoid this problem, take the effect of back-EMF into consideration in system design.

About solder ability, following conditions were confirmed

- Solder ability

- (1) Use of Sn-37Pb solder Bath
- solder bath temperature = 230°C
 - dipping time = 5 seconds
 - the number of times = once
 - use of R-type flux
- (2) Use of Sn-3.0Ag-0.5Cu solder Bath
- solder bath temperature = 245°C
 - dipping time = 5 seconds
 - the number of times = once
 - use of R-type flux

RESTRICTIONS ON PRODUCT USE RESTRICTIONS ON PRODUCT USE

- Toshiba Corporation, and its subsidiaries and affiliates (collectively "TOSHIBA"), reserve the right to make changes to the information in this document, and related hardware, software and systems (collectively "Product") without notice.
- This document and any information herein may not be reproduced without prior written permission from TOSHIBA. Even with TOSHIBA's written permission, reproduction is permissible only if reproduction is without alteration/omission.
- Though TOSHIBA works continually to improve Product's quality and reliability, Product can malfunction or fail. Customers are responsible for complying with safety standards and for providing adequate designs and safeguards for their hardware, software and systems which minimize risk and avoid situations in which a malfunction or failure of Product could cause loss of human life, bodily injury or damage to property, including data loss or corruption. Before customers use the Product, create designs including the Product, or incorporate the Product into their own applications, customers must also refer to and comply with (a) the latest versions of all relevant TOSHIBA information, including without limitation, this document, the specifications, the data sheets and application notes for Product and the precautions and conditions set forth in the "TOSHIBA Semiconductor Reliability Handbook" and (b) the instructions for the application with which the Product will be used with or for. Customers are solely responsible for all aspects of their own product design or applications, including but not limited to (a) determining the appropriateness of the use of this Product in such design or applications; (b) evaluating and determining the applicability of any information contained in this document, or in charts, diagrams, programs, algorithms, sample application circuits, or any other referenced documents; and (c) validating all operating parameters for such designs and applications. **TOSHIBA ASSUMES NO LIABILITY FOR CUSTOMERS' PRODUCT DESIGN OR APPLICATIONS.**
- Product is intended for use in general electronics applications (e.g., computers, personal equipment, office equipment, measuring equipment, industrial robots and home electronics appliances) or for specific applications as expressly stated in this document. Product is neither intended nor warranted for use in equipment or systems that require extraordinarily high levels of quality and/or reliability and/or a malfunction or failure of which may cause loss of human life, bodily injury, serious property damage or serious public impact ("Unintended Use"). Unintended Use includes, without limitation, equipment used in nuclear facilities, equipment used in the aerospace industry, medical equipment, equipment used for automobiles, trains, ships and other transportation, traffic signaling equipment, equipment used to control combustions or explosions, safety devices, elevators and escalators, devices related to electric power, and equipment used in finance-related fields. Do not use Product for Unintended Use unless specifically permitted in this document.
- Do not disassemble, analyze, reverse-engineer, alter, modify, translate or copy Product, whether in whole or in part.
- Product shall not be used for or incorporated into any products or systems whose manufacture, use, or sale is prohibited under any applicable laws or regulations.
- The information contained herein is presented only as guidance for Product use. No responsibility is assumed by TOSHIBA for any infringement of patents or any other intellectual property rights of third parties that may result from the use of Product. No license to any intellectual property right is granted by this document, whether express or implied, by estoppel or otherwise.
- **ABSENT A WRITTEN SIGNED AGREEMENT, EXCEPT AS PROVIDED IN THE RELEVANT TERMS AND CONDITIONS OF SALE FOR PRODUCT, AND TO THE MAXIMUM EXTENT ALLOWABLE BY LAW, TOSHIBA (1) ASSUMES NO LIABILITY WHATSOEVER, INCLUDING WITHOUT LIMITATION, INDIRECT, CONSEQUENTIAL, SPECIAL, OR INCIDENTAL DAMAGES OR LOSS, INCLUDING WITHOUT LIMITATION, LOSS OF PROFITS, LOSS OF OPPORTUNITIES, BUSINESS INTERRUPTION AND LOSS OF DATA, AND (2) DISCLAIMS ANY AND ALL EXPRESS OR IMPLIED WARRANTIES AND CONDITIONS RELATED TO SALE, USE OF PRODUCT, OR INFORMATION, INCLUDING WARRANTIES OR CONDITIONS OF MERCHANTABILITY, FITNESS FOR A PARTICULAR PURPOSE, ACCURACY OF INFORMATION, OR NONINFRINGEMENT.**
- Do not use or otherwise make available Product or related software or technology for any military purposes, including without limitation, for the design, development, use, stockpiling or manufacturing of nuclear, chemical, or biological weapons or missile technology products (mass destruction weapons). Product and related software and technology may be controlled under the Japanese Foreign Exchange and Foreign Trade Law and the U.S. Export Administration Regulations. Export and re-export of Product or related software or technology are strictly prohibited except in compliance with all applicable export laws and regulations.
- Please contact your TOSHIBA sales representative for details as to environmental matters such as the RoHS compatibility of Product. Please use Product in compliance with all applicable laws and regulations that regulate the inclusion or use of controlled substances, including without limitation, the EU RoHS Directive. TOSHIBA assumes no liability for damages or losses occurring as a result of noncompliance with applicable laws and regulations.

单击下面可查看定价，库存，交付和生命周期等信息

[>>Toshiba\(东芝\)](#)