

General Description

SN74LVC1G08 is a 2-input and gate integrated circuit, which can realize the mathematical logic operation of 74LV. Advanced CMOS process design, with low power consumption and high output driving capability, the power supply voltage V_{CC} between 1.65V and 5.5V chip can work normally. SN74LVC1G08 has a variety of small encapsulation shapes, which can be widely used in high-end precision instruments, miniaturized and low-power handheld devices and artificial intelligence.

Features

- Low input current.
- Low static power consumption. $I_{cc}=0.1\mu A$.
- High output drive. $V_{CC}=4.5V$.
- Wide operating voltage range. 1.65V-5.5V
- Packaging form: DBV/DRL/YZP/DCK DRP/DSF/DPW

Applications

- Portable audio interface
- Blu-ray players and home theaters
- Solid state drives
- Digital TV
- Wireless headphones, smart watches, etc
- Smart wearable Devices

Pinning and Package

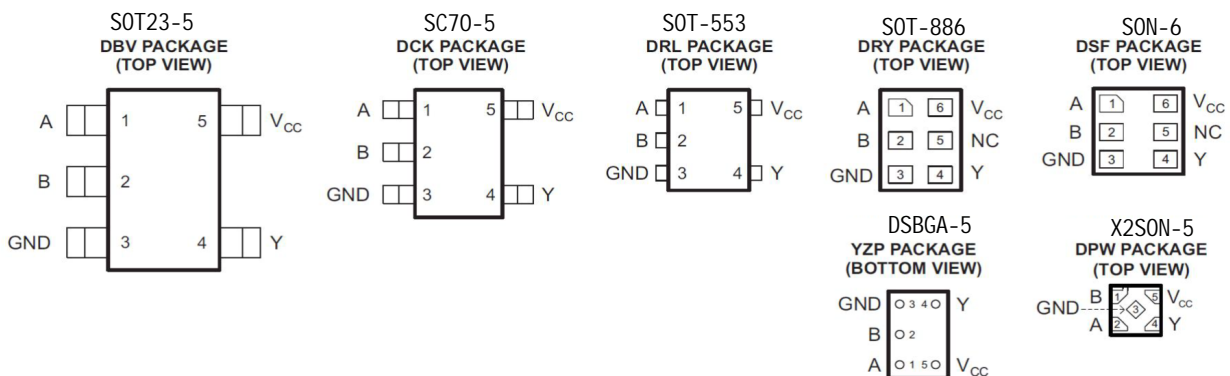

Pin Functions

NAME	PIN			DESCRIPTION
	DBV, DCK, DRL, YZP	DRY, DSF	DPW	
A	1	1	2	Input
B	2	2	1	Input
GND	3	3	3	Ground
Y	4	4	4	Output
V_{CC}	5	6	5	Power pin
NC		5		Not connected

Absolute Maximum Ratings

		MIN	MAX	UNIT
V _{CC}	Supply voltage range	-0.5	6.5	V
V _I	Input voltage range ⁽²⁾	-0.5	6.5	V
V _O	Voltage range applied to any output in the high-impedance or power-off state ⁽²⁾	-0.5	6.5	V
V _O	Voltage range applied to any output in the high or low state ⁽²⁾⁽³⁾	-0.5	V _{CC} + 0.5	V
I _{IK}	Input clamp current	V _I < 0	-50	mA
I _{OK}	Output clamp current	V _O < 0	-50	mA
I _O	Continuous output current		±50	mA
	Continuous current through V _{CC} or GND		±100	mA
T _{J(max)}	Junction temperature		150	°C
T _{stg}	Storage temperature	-65	150	°C

- (1) Stresses beyond those listed under *Absolute Maximum Ratings* may cause permanent damage to the device. These are stress ratings only, and functional operation of the device at these or any other conditions beyond those indicated under *Recommended Operating Conditions* is not implied. Exposure to absolute-maximum-rated conditions for extended periods may affect device reliability.
- (2) The input and output negative-voltage ratings may be exceeded if the input and output current ratings are observed.
- (3) The value of V_{CC} is provided in the *Recommended Operating Conditions* table.

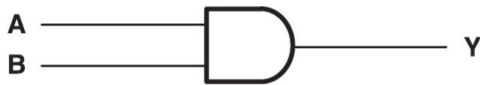
Functional Block Diagram

Device Functional Modes

Inputs		Output
A	B	Y
L	L	L
L	H	L
H	L	L
H	H	H

Recommended Operating Conditions

			MIN	MAX	UNIT
V _{CC}	Supply voltage	Operating	1.65	5.5	V
		Data retention only	1.5		
V _{IH}	High-level input voltage	V _{CC} = 1.65 V to 1.95 V	0.65 × V _{CC}		V
		V _{CC} = 2.3 V to 2.7 V	1.7		
		V _{CC} = 3 V to 3.6 V	2		
		V _{CC} = 4.5 V to 5.5 V	0.7 × V _{CC}		
V _{IL}	Low-level input voltage	V _{CC} = 1.65 V to 1.95 V		0.35 × V _{CC}	V
		V _{CC} = 2.3 V to 2.7 V		0.7	
		V _{CC} = 3 V to 3.6 V		0.8	
		V _{CC} = 4.5 V to 5.5 V		0.3 × V _{CC}	
V _I	Input voltage		0	5.5	V
V _O	Output voltage		0	V _{CC}	V
I _{OH}	High-level output current	V _{CC} = 1.65 V		-4	mA
		V _{CC} = 2.3 V		-8	
		V _{CC} = 3 V		-16	
		V _{CC} = 4.5 V		-24	
I _{OL}	Low-level output current	V _{CC} = 1.65 V		4	mA
		V _{CC} = 2.3 V		8	
		V _{CC} = 3 V		16	
		V _{CC} = 4.5 V		24	
		V _{CC} = 4.5 V		32	

- (1) All unused inputs of the device must be held at V_{CC} or GND to ensure proper device operation. Refer to the TI application report, *Implications of Slow or Floating CMOS Inputs*, literature number [SCBA004](#).

Electrical Characteristics

over recommended operating free-air temperature range (unless otherwise noted)

PARAMETER		TEST CONDITIONS	V _{CC}	TYP	MAX	UNIT
V _{OH}		I _{OH} = -100uA	1.65V~5.5V	1.64	-	V
		I _{OH} = -4 mA	1.65V	1.47	-	
		I _{OH} = -8 mA	2.3V	2.15	-	
		I _{OH} = -16 mA	3V	2.73	-	
		I _{OH} = -32 mA	4.5V	4.0	-	
V _{OL}		I _{OH} = 100uA	1.65V~5.5V	0.01	-	V
		I _{OH} = 4 mA	1.65V	0.11	-	
		I _{OH} = 8 mA	2.3V	0.11	-	
		I _{OH} = 16 mA	3V	0.2	-	
		I _{OH} = 32 mA	4.5V	0.35	-	
I _I	A	V _I = 5.5V or GND	0~5.5V	0.01	±5	uA
	B			0.01	±5	
I _{OFF}	V _I	V _I = 5.5V	0	0.01	±10	uA
	V _O	V _O = 5.5V	0	0.01	±10	
I _{CC}		V _I = 5.5V, I _O = 0	1.65V~5.5V	0.01	10	uA
		V _I = GND, I _O = 0		0.01	10	
ΔI _{CC}		A = V _{CC} - 0.6V	3V~5.5V	25	-	uA
		B = V _{CC} or GND				
		B = V _{CC} - 0.6V A = V _{CC} or GND		25	-	

 (1) All typical values are at V_{CC} = 3.3 V, T_A = 25°C.

Switching Characteristics, C_L = 15 pF

over recommended operating free-air temperature range (unless otherwise noted) (see

PARAMETER	FROM (INPUT)	TO (OUTPUT)	-40°C to 85°C								UNIT
			V _{CC} = 1.8 V ± 0.15 V		V _{CC} = 2.5 V ± 0.2 V		V _{CC} = 3.3 V ± 0.3 V		V _{CC} = 5 V ± 0.5 V		
			MIN	MAX	MIN	MAX	MIN	MAX	MIN	MAX	
t _{pd}	A or B	Y	1.5	7.2	0.7	4.4	0.8	3.6	0.8	3.4	ns

Package Outline

DBV (SOT23-5)

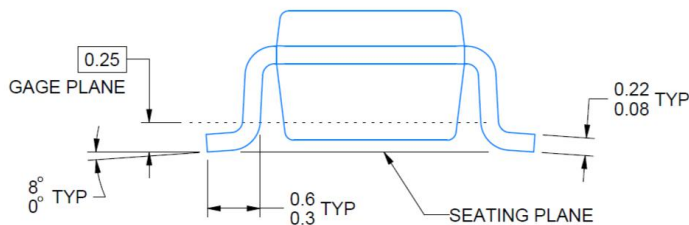
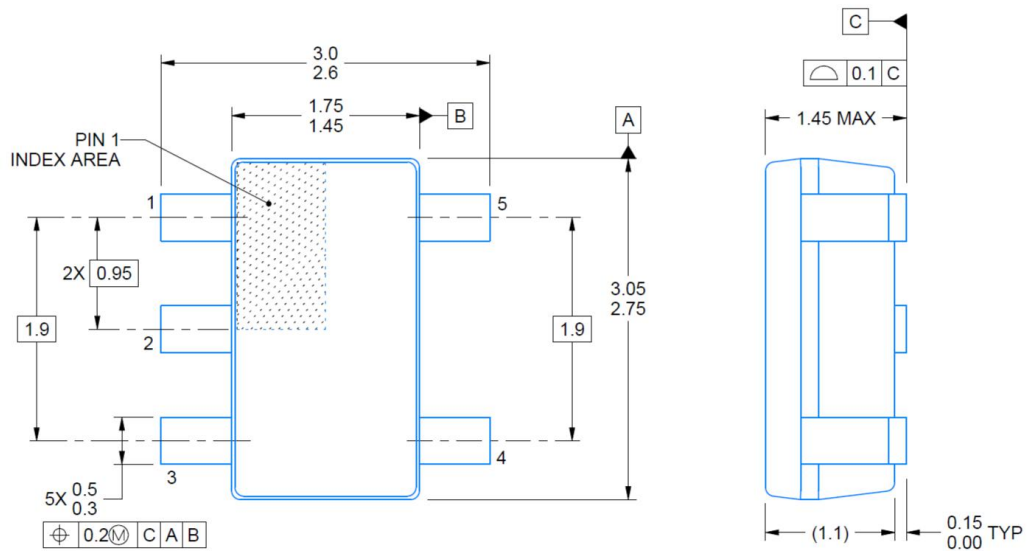

Marking

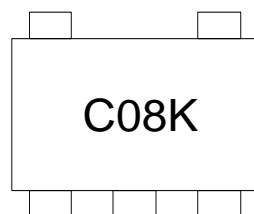

DCK (SC70-5)

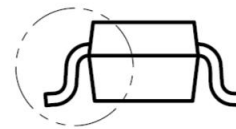
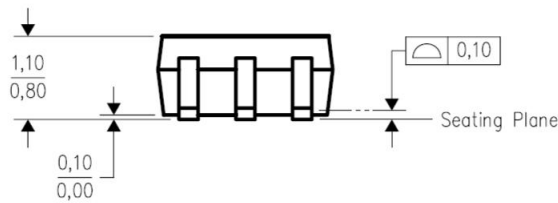
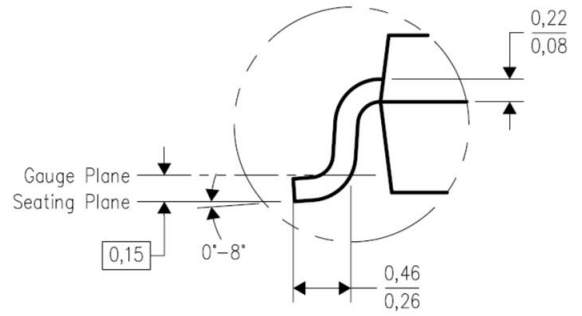
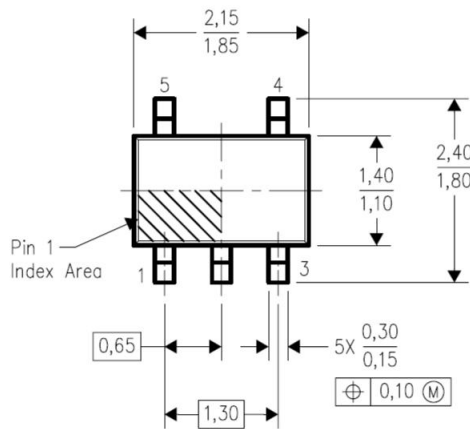

Marking

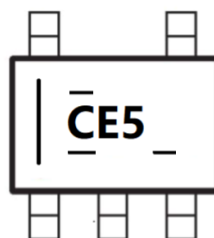

DRL (SOT-553)

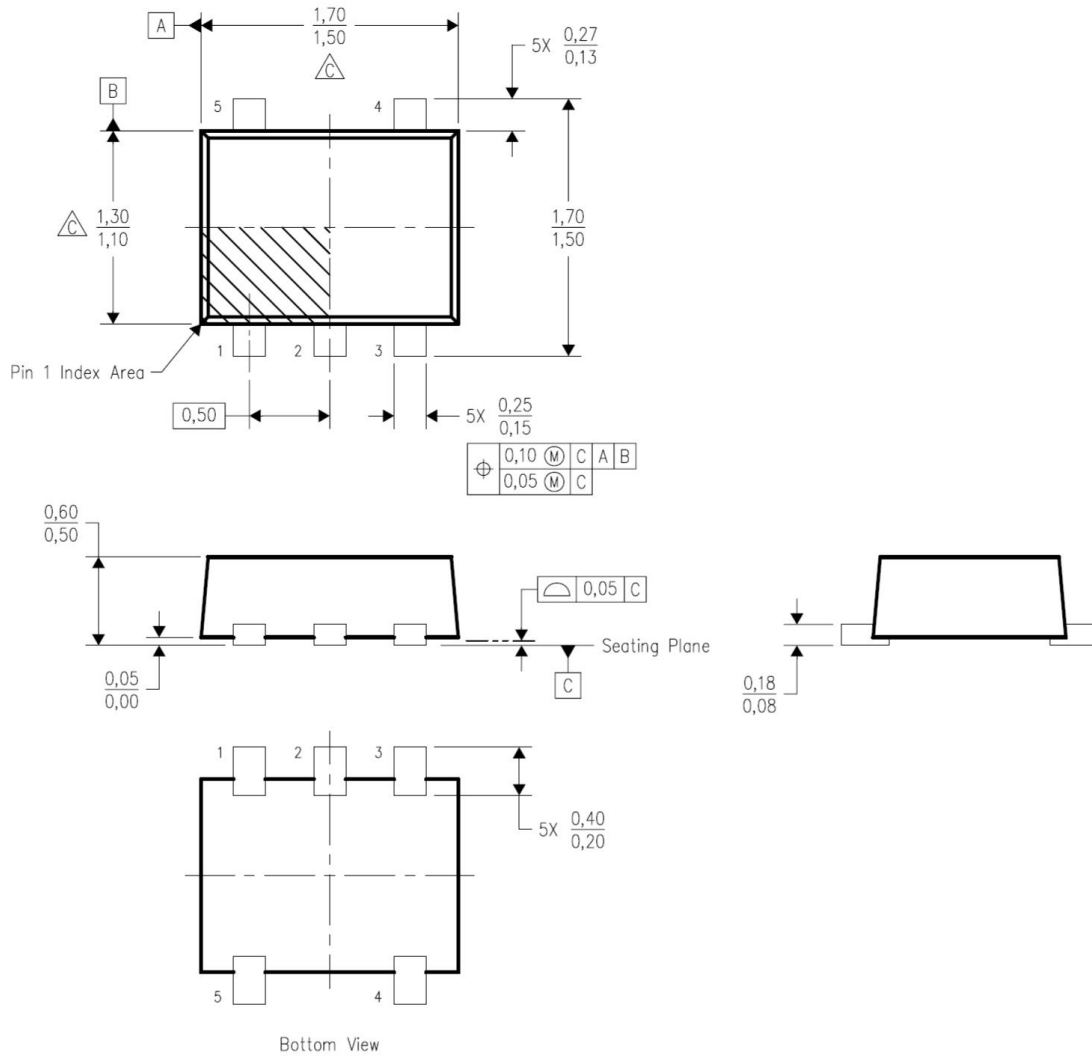

DRY (SOT-886)

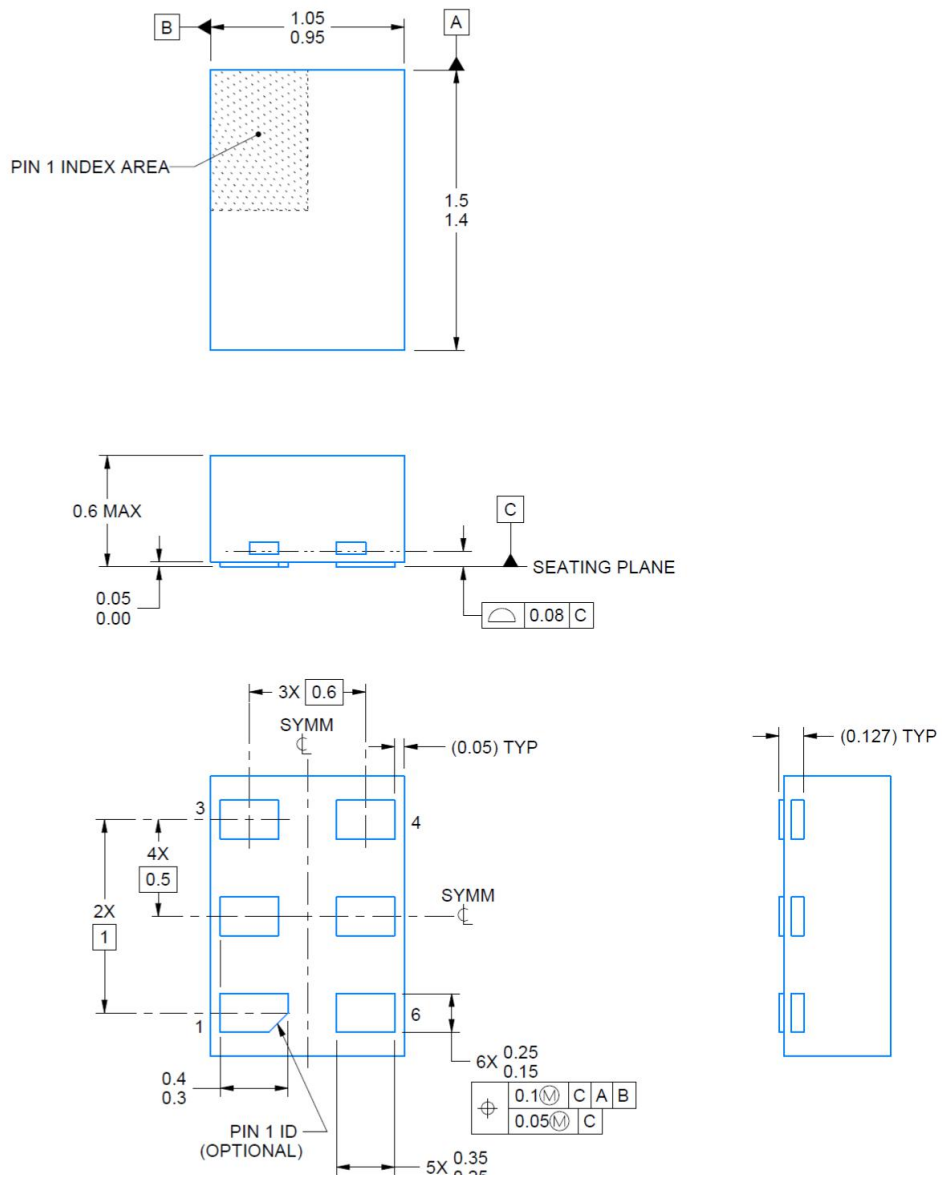

DSF (SON-6)

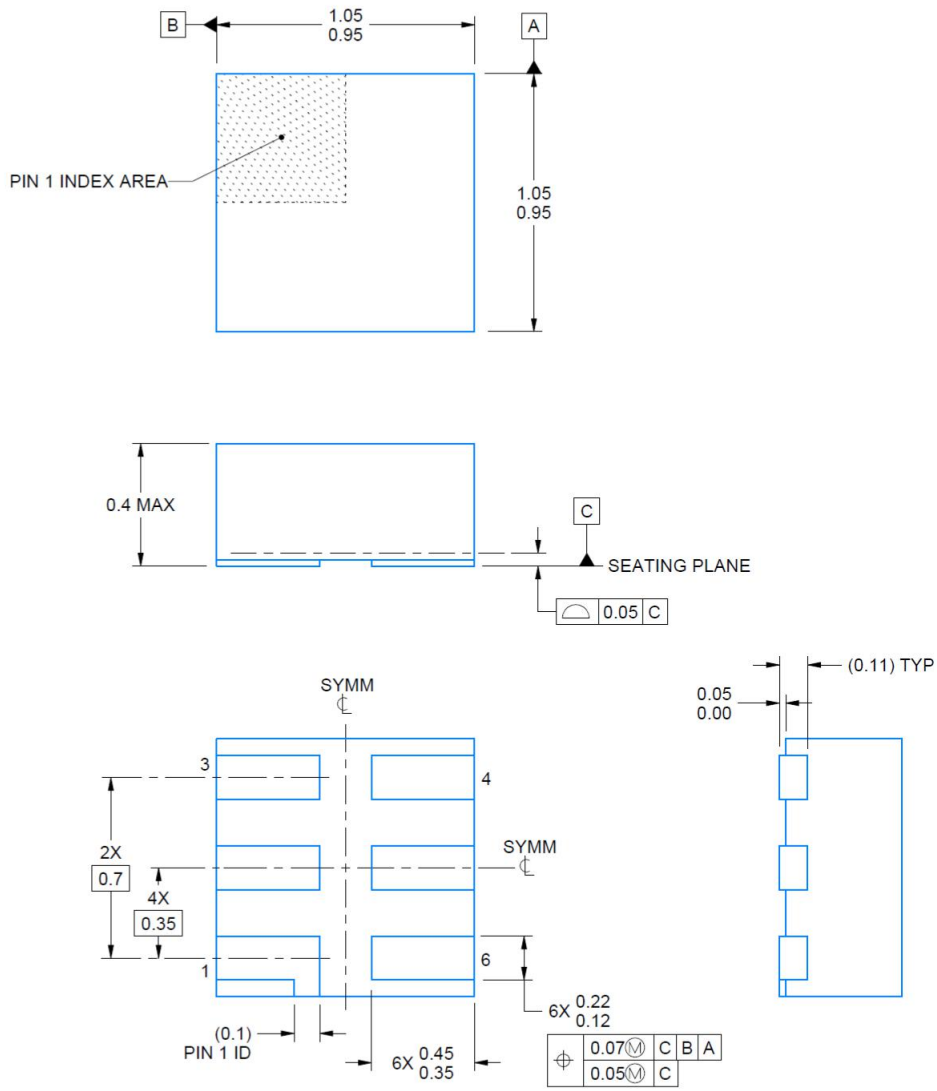

YZP (DSBGA-5)

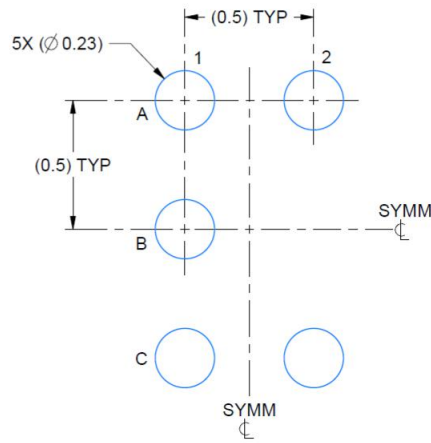

LAND PATTERN EXAMPLE
SCALE:40X

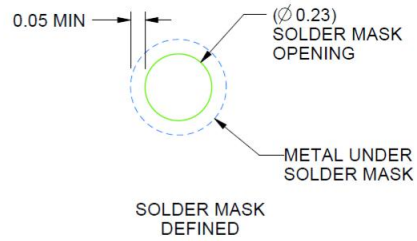
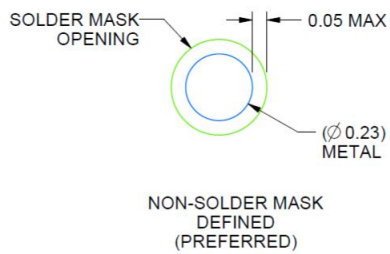

DPW (X 2SON-5)

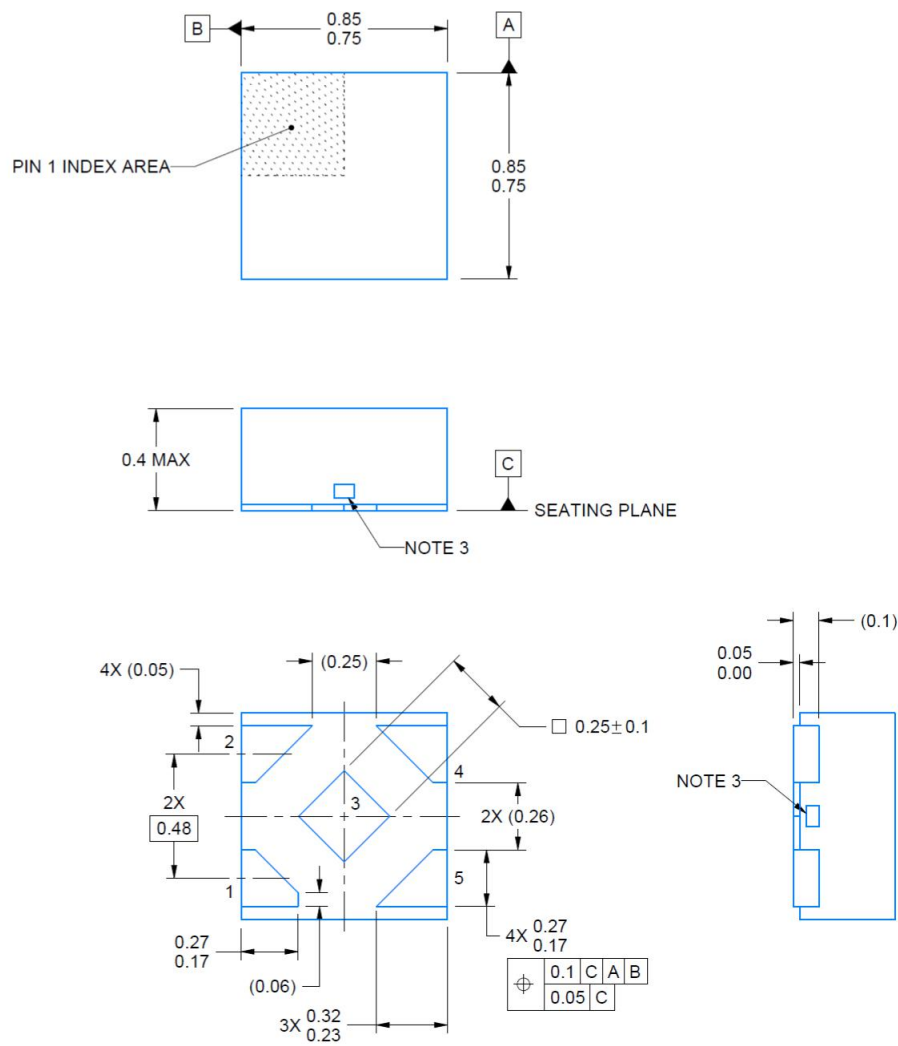

单击下面可查看定价，库存，交付和生命周期等信息

[>>TWGMC\(台湾迪嘉\)](#)