

SPECIFICATION FOR APPROVAL

CUSTOMER : _____

PRODUCT TYPE : SMD TCXO 3.2 * 2.5

NOMINAL FREQ. : 26 MHz

TXC P/N : 7Q26000001

REVISION : A3

CUSTOMER P/N : _____

PM / SALES : _____

DATE : _____

CUSTOMER SIGNATURE & DATE
: _____

- (1) TXC requires one copy returned with signature and title of authorized individual that signifies acceptance of the attached specifications.
- (2) Orders received and accepted by TXC after return of signed copy of specification will be produced per these specifications.
- (3) Any changes to these specifications must be agreed upon by both parties and new revision of the Product Specification Sheet will be issued.
- (4) Any issuance of purchase order prior to consigning back the Approval page of "Specification Sheets" from customers will be regarded as the agreement on the contents of these specifications.

Attachment: Product Specification Sheet

- 1
- 2
- 3
- 4
- 5

RoHS Compliant

PRODUCT SPECIFICATION SHEET

PRODUCT TYPE : SMD TCXO 3.2 * 2.5

NOMINAL FREQ. : 26 MHz

TXC P/N : 7Q26000001

REVISION : A3

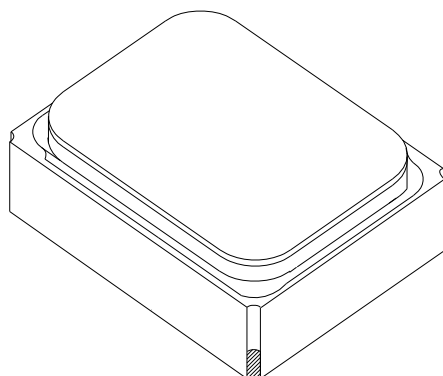

PE/RD	QA	MFG
<i>Eric Tsao</i> Eric Tsao	<i>Alex Huang</i> Alex Huang	<i>Hungte Liu</i> Hungte Liu
28-Oct-14	28-Oct-14	28-Oct-14

NOTE:

- (1) The green product standard set by TXC is based upon the international standards. Related information is publicly described on the TXC's Website, and updated regularly. The document is compliant with the latest green product quality system directives at the time.
- (2) Revision "Sx" is for engineering samples only. PE/RD's approval required.
- (3) Revision "Ax" is production ready. PE, QA and MFG's approval required.

RoHS Compliant

PRODUCT TYPE: SMD TCXO 3.2 * 2.5

P/N : 7Q2600001

REVISION : A3

<u>Rev</u>	<u>Revise page</u>	<u>Revise contents</u>	<u>Date</u>	<u>Ref.No.</u>	<u>Reviser</u>
A1	N/A	Initial Released	2008/4/17	N/A	Cheese Chiang
A2	2, 4	TC Slope Change Weight Revised	2008/9/3	ECN-08P091205	Cheese Chiang
A3	3	Dimensions Change	2014/10/28	EC-PCF-140925-05	Su-Chen Chiang

■ ELECTRICAL SPECIFICATIONS

Item	Parameters		Condition	Electrical Specifications				Note
				MIN	TYP	MAX	UNITS	
1	Nominal Frequency			26.000000			MHz	
2	Operating Temperature Range			-30		+85	°C	
3	Supply Voltage			2.60	2.80	3.00	V	
4	Current Drain				1.5		mA	
5	Output Level			0.8			V	1
6	Output Type			Clipped Sinewave				
7	Output Load		Resistance	9	10	11	kΩ	
8			Capacitance	9	10	11	pF	
9	Frequency Tolerance		After 2 times reflow			±2.0	ppm	2
10	Frequency Stability	vs. Temperature	Temp: -30 ~ +85°C			±0.5	ppm	3
11		vs. Load	Load: 10 kΩ // 10 pF ±10%			±0.2	ppm	
12		vs. Supply Voltage	Vcc: 2.8 V ±5%			±0.2	ppm	
13	Slope of Frequency Drift over Temperature					0.1	ppm/°C	4
14	Storage Temperature			-40		+85	°C	
15	Start-up Time	vs. Frequency	Within ± 1 ppm			2.5	ms	
16		vs. Output Level	To 90% of Vp-p			2.5	ms	
17	Duty Cycle			40	50	60	%	
18	Aging over 1st Year					±1.0	ppm	
19	Harmonics					-7	dBc	
20	Phase Noise	@ 10 Hz offset			-70		dBc/Hz	
21		@ 100 Hz offset			-105		dBc/Hz	
22		@ 1 kHz offset				-130		dBc/Hz
23		@ 10 kHz offset				-145		dBc/Hz

Note 1 Decoupling capacitor is required in external circuit.

Note 2 Refer to nominal frequency

Note 3 Refer to frequency at 25±2°C

Note 4 Minimum of 1 frequency reading every 2°C over temperature, based on temperature varied at maximum of 2°C per minute.

TESTING CIRCUIT

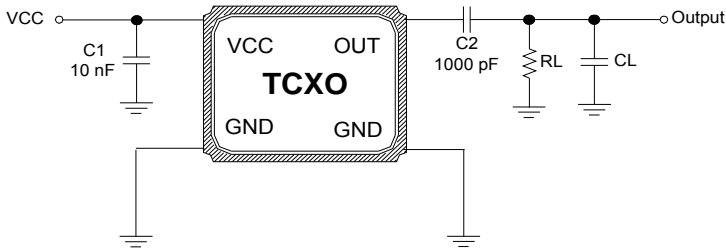

External Components

Name	Function
C1	AC Noise Bypass for VCC
C2	DC Block for Output
RL	Load Resistance
CL	Load Capacitance

Note: Bypass capacitor (C1) and DC blocking capacitor (C2) should be placed.

DIMENSIONS

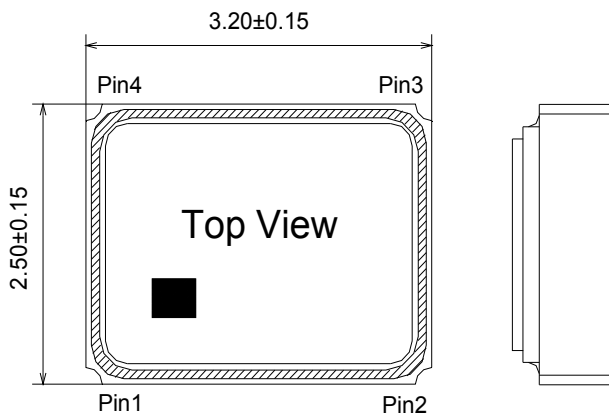

Pin Function

Name	Function
Pin 1	GND or NC
Pin 2	GND
Pin 3	OUTPUT
Pin 4	VCC

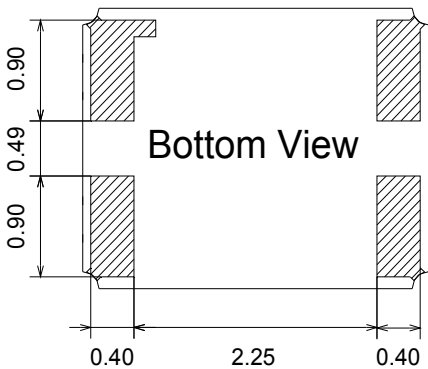
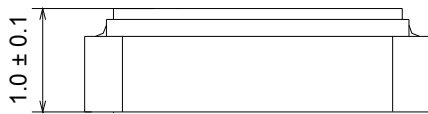

Land Pattern

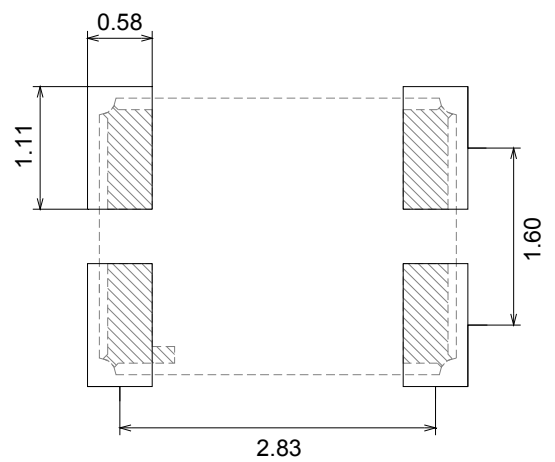

Unit : mm

■ SUGGESTED REFLOW PROFILE

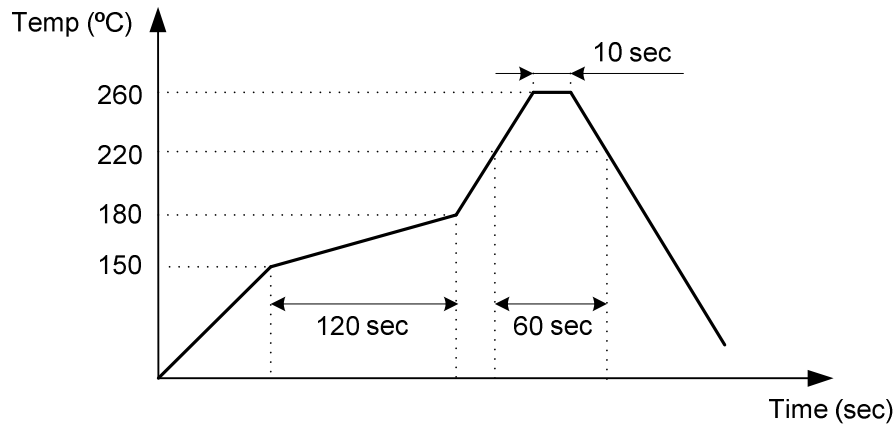

Note 1: Period while temperature exceeds the solder melting point : 220°C should be less than 200 sec.

Note 2: Period while temperature stays at the top melting point : 260°C should be less than 30 sec.

■ MARKING

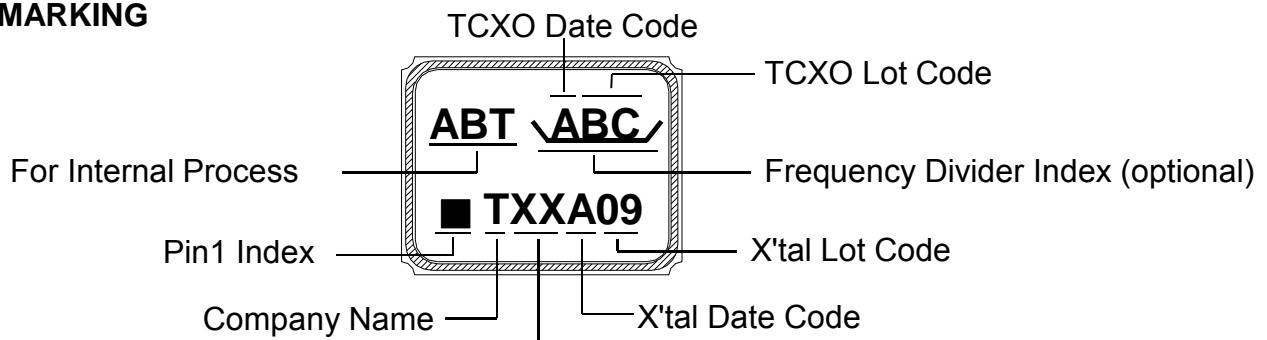

DATE CODE

				MONTH											
YEAR				JAN	FEB	MAR	APR	MAY	JUN	JUL	AUG	SEP	OCT	NOV	DEC
2005	2009	2013	2017	A	B	C	D	E	F	G	H	J	K	L	M
2006	2010	2014	2018	N	P	Q	R	S	T	U	V	W	X	Y	Z
2007	2011	2015	2019	a	b	c	d	e	f	g	h	j	k	l	m
2008	2012	2016	2020	n	p	q	r	s	t	u	v	w	x	y	z

* This date code will be cycled every four years.

Note: If TCXO frequency is X'tal frequency divided by 2, then frequency divider index appears.

If TCXO frequency is the same as X'tal frequency, then no frequency divider index appears.

■ **PACKING : (EIA-481-2)**

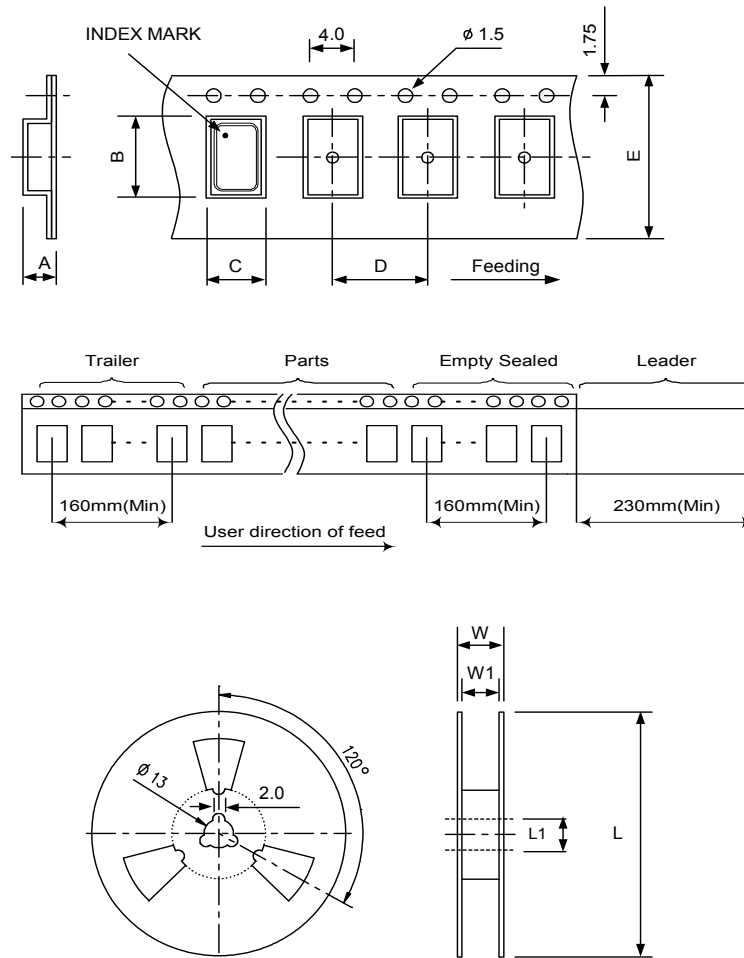

Unit: mm

DIMENSIONS (mm)	A	B	C	D	E	L	L1	W	W1	Standard Reel Quantity is 3,000 pcs per reel
	1.40	3.40	2.70	4.00	8.0	178.0	13.0	11.5	8.0	

■ **WEIGHT**

0.0219 g / piece(TYP), 65 ± 2 g /3 kpcs (regardless of tape weight)

■ **STRUCTURE ILLUSTRATION**

Crystal Enclosure Seal: Seam Welding

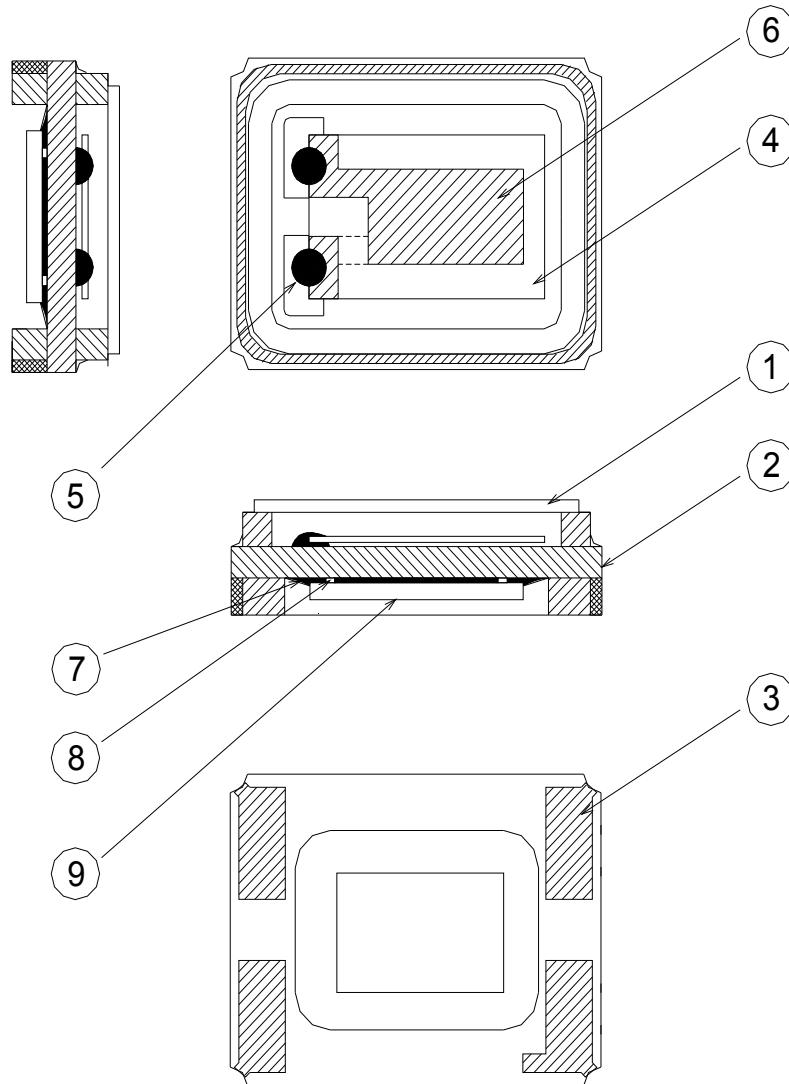

No.	COMPONENTS	MATERIALS	FINISH/SPECIFICATIONS
1	Cap	Metal(Fe + Co + Ni)	-
2	Base	Ceramic	Color Black
3	Pad	Au	Tungsten Metalize + Ni Plating + Au Plating
4	Crystal Blank	SiO ₂	-
5	Conductive Adhesive	Ag	Silicone Resin
6	Electrode	Noble Metal	-
7	Underfill	Organic	Color Black
8	Bump	Au	
9	IC	Si	

■ RELIABILITY SPECIFICATIONS

1. Mechanical Endurance

No.	Test Item	Test Methods	Criteria
1.1	Drop Test	Height : 100 cm height Direction : X,Y,Z 6 directions Test cycles : 3 cycles Fall freely on to concrete floor Mounting on test fixture (total weight=100 g)	+/- 2.0 ppm
1.2	Mechanical Shock	Acceleration : 1000 g Duration : 0.5 ms Test cycles : 3 times for all 3 directions	+/- 2.0 ppm
1.3	Vibration	Frequency range : 10 ~ 2000 Hz Amplitude : 1.52 mm (10 ~ 80 Hz) Acceleration : 20 g (80 ~ 2000 Hz) Sweep speed : 20 minutes/cycle Direction : X,Y,Z 3 directions Duration : 4 hours/each direction	+/- 2.0 ppm
1.4	Gross Leak	Standard sample for automatic gross leak detector. Test Pressure : 2 kg / cm ²	< 1.5 × 10 ⁻⁵ Pa m ³ / sec
1.5	Fine Leak	Helium bombing 4.5 kg / cm ² for 2 hours	< 1.0 × 10 ⁻⁹ Pa m ³ / sec
1.6	Solderability	Preheate temperature : 125°C ± 5°C Preheate time : 120 sec Soldering temperature : 245°C ± 5°C Duration : 5 ± 1 sec Method : Solder bath method	90% Coated

[Note] Criteria mean the maximum frequency change after reliability test, frequency shall be measured at 25°C.

2. Environmental Endurance

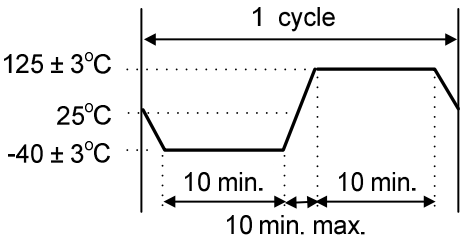
No.	Test Item	Test Methods	Criteria
2.1	High Temp. Storage	Temperature : +125°C ± 3°C Duration : 168 hours	+/- 2.0 ppm
2.2	Low Temp. Storage	Temperature : -40°C ± 3°C Duration : 500 hours	+/- 2.0 ppm
2.3	Thermal Shock (Air to Air)	Total 100 cycles of the following temperature cycle : 	+/- 2.0 ppm
2.4	High Temp & Humidity	Temperature : 85°C ± 3°C Humidity: RH 85% Duration : 168 hours	+/- 2.0 ppm
2.5	Aging	Temperature : 85°C ± 3°C Duration : 500 hours Voltage input by specification	+/- 2.0 ppm

[Note] Criteria mean the maximum frequency change after reliability test, frequency shall be measured after 2 hours at 25°C leaving.

单击下面可查看定价，库存，交付和生命周期等信息

[>>TXC\(台湾晶技\)](#)