

SPECIFICATION FOR APPROVAL

CN: 0

CUSTOMER : _____
PRODUCT TYPE : SMD GLASS SEALING X'TAL 3.2*2.5
NOMINAL FREQ. : 55.466670MHz
TXC P/N : AV55400010
REVISION : A1
CUSTOMER P/N : _____
PM / SALES : _____
DATE : _____
CUSTOMER SIGNATURE & Date

- (1) TXC requires one copy returned with signature and title of authorized individual that signifies acceptance of the attached specifications.
- (2) Orders received and accepted by TXC after return of signed copy of specification will be produced per these specifications.
- (3) Any changes to these specifications must be agreed upon by both parties and new revision of the Product Specification Sheet will be issued.
- (4) Any issuance of purchase order prior to consigning back the Approval page of "Specification Sheets" from customers will be regarded as the agreement on the contents of these specifications.

**MSL:Level 1
RoHS Compliant**

Pb used in sealing glass material is exempt from EU directive

PRODUCT SPECIFICATION SHEET

CN: _____

PRODUCT TYPE : SMD GLASS SEALING X'TAL 3.2*2.5

NOMINAL FREQ. : 55.466670MHz

TXC P/N : AV55400010

REVISION : A1

PE/RD	QA	MFG
<i>Wen yuan Chang</i>	<i>ZhongLin Wu</i>	<i>Zhi Jun Wu</i>
Wen yuan Chang	ZhongLin Wu	Zhi jun Wu
<i>19-Apr-19</i>	<i>19-Apr-19</i>	<i>19-Apr-19</i>

NOTE:

- (1) The green product standard set by TXC is based upon the international standards. Related information is publicly described on the TXC's Website, and updated regularly. The document is compliant with the latest green product quality system directives at the time.
- (2) Revision "Sx" is for engineering samples only. PE/RD's approval required.
- (3) Revision "Ax" is production ready. PE, QA and MFG's approval required

**MSL:Level 1
RoHS Compliant**

Pb used in sealing glass material is exempt from EU directive

Spec Sheet Contents

No.	Content	Page
1	ELECTRICAL SPECIFICATIONS & Attention	P.3
2	DIMENSIONS	P.4
3	MARKING	P.4
4	FACTORY LOCATION	P.4
5	SUGGESTED REFLOW PROFILE& MANUAL SOLDER CONDITION	P.4
6	STRUCTURE ILLUSTRATION	P.5
7	EMBOSS CARRIER TAPE & REEL	P.6
8	PACKING	P.7
9	RELIABILITY SPECIFICATIONS	P.8~9

■ ELECTRICAL SPECIFICATIONS

	Parameters	SYM.	Electrical Spec.				Notes
			MIN	TYP	MAX	UNITS	
1	Nominal Frequency	FL	55.466670			MHz	-
2	Oscillation Mode	-	Fundamental			-	-
3	Load Capacitance	CL	6			pF	-
4	Frequency Tolerance	-	±30			ppm	at 25 °C ± 3 °C
5	Frequency Stability	-	±50			ppm	Over Operating Temp. Range (Reference 25°C)
6	Operating Temperature	-	-40	~	125	°C	-
7	Aging	-	±3			ppm	1st Year at 25 °C ± 3 °C
8	Drive Level	DL	-	50	100	uW	-
9	Series Resonant Resistance	Rr	-	-	50	Ω	-
10	Shunt Capacitance	C0	-	-	2	pF	-
11	Insulation Resistance	-	500	-	-	MΩ	at DC 100V
12	Storage Temperature Range	-	-40	~	125	°C	-

Measure equipment

Electrical characteristics measured by S&A250B or equivalent.

Unit Weight:

0.020±0.002 g/pcs

■ Attention (注意事項) :

1. If you intend to use product on controls relating to medical equipment, aeronautical equipment, aerospace, military science, space equipment, etc.) please do not fail to advise us of your intention beforehand.
請勿將本產品使用在醫療,航空,宇航,軍事或與生命安全性相關的設備中, 若需使用在上述應用請事前與TXC聯繫。
2. Crystal units will be damaged by ultrasonic welding process due to resonance of crystal wafer itself.
If ultrasonic welding used, TXC strongly recommend verifying damage by ultrasonic weld.
本產品在超音波封合的過程中晶片可能會因共振受損, 若有超音波封合需求,TXC強烈建議應給予適當的驗證。
3. Crystal units will be damaged by plastic molding process due to pressure. If plastic molding used, TXC strongly recommend use seam welding products instead.
本產品在熱塑封合的過程中結構可能會受到熱壓力而損壞, 若有熱塑封合需求,請給以適當的驗證。

■ DIMENSION

(Unit:mm)

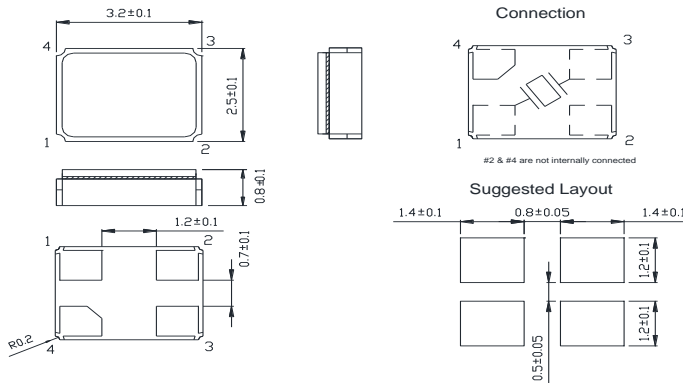

*Coplanarity of solderable areas Camber 0.10 mm Max

■ MARKING

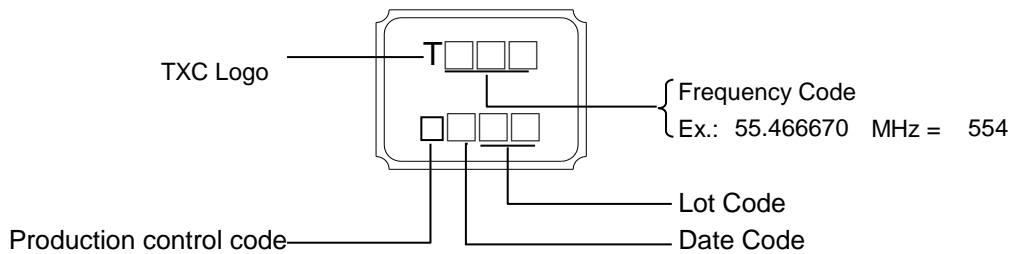

Production Location:China(Ningbo)

Month Code:

YEAR					MONTH												
2005	2009	2013	2017	2021	JAN	FEB	MAR	APR	MAY	JUN	JUL	AUG	SEP	OCT	NOV	DEC	
A	B	C	D	E	F	G	H	J	K	L	M	N	P	Q	R	S	T
U	V	W	X	Y	Z	a	b	c	d	e	f	g	h	j	k	l	m
n	p	q	r	s	t	u	v	w	x	y	z						

*This month code will be cycled every four years

■ SUGGESTED REFLOW PROFILE

Solder melting point :220±10 °C, 60 sec. Min.
 Peak Temperature: 260 ± 5 °C, 10 sec. Max.
 Reflow passage time : twice

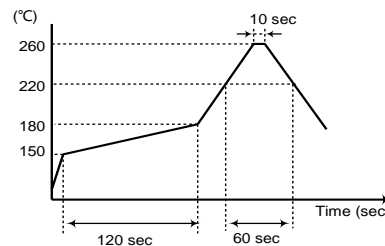

■ SUGGESTED MANUAL SOLDER CONDITION

Pressing a soliding iron of 350 °C on the terminal electrode for 4 seconds (twice).
 When using a soldering iron, press its tip on the part below the sealed part, avoiding glass-sealed part (otherwise, the glass will melt and air-tightness may be lost).

NOTE: After manual welding, the product should be placed at least 2 hours

■ STRUCTURE ILLUSTRATION

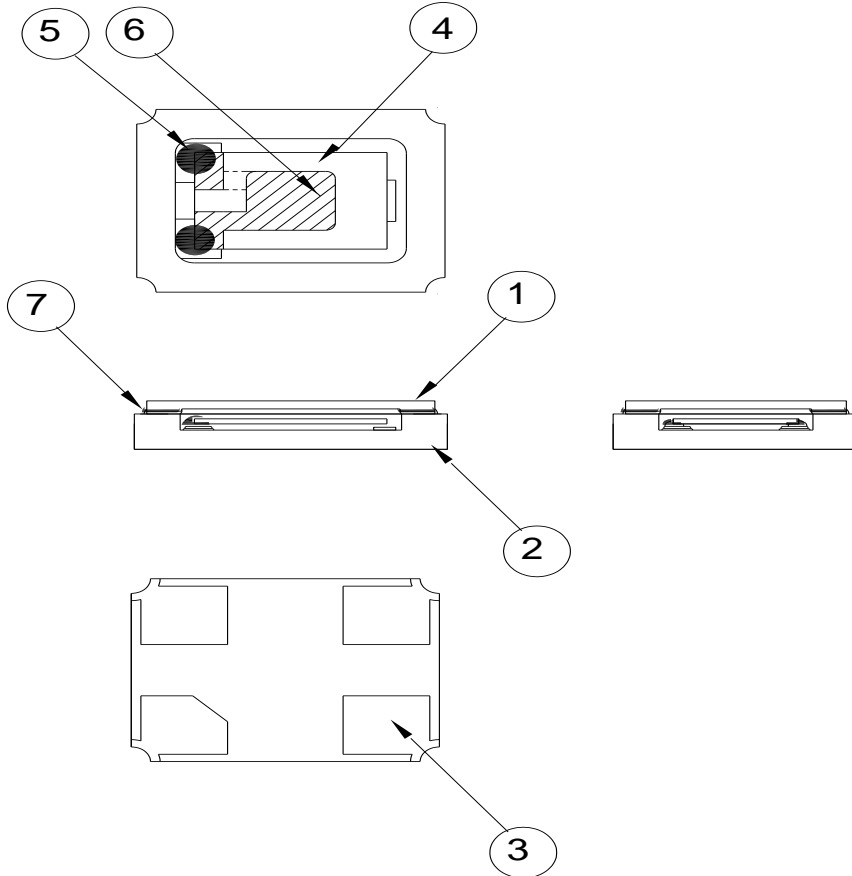

NO	COMPONENTS	MATERIALS	FINISH/SPECIFICATIONS
1	Cap	Ceramic (Al ₂ O ₃)	-
2	Package	Ceramic (Al ₂ O ₃)	-
3	PAD	Au	Tungsten metalize + Ni plating + Au plating
4	Crystal blank	SiO ₂	-
5	Conductive adhesive	Resin+Ag	-
6	Electrode	Noble Metal	-
7	Sealing Glass	Glass(PbO)	-

EMBOSS CARRIER TAPE & REEL

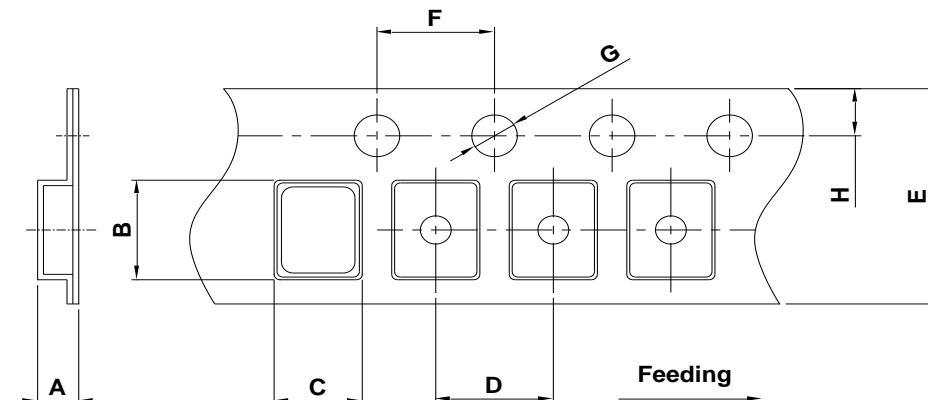

DIMENSIONS	A	B	C	D	E	F	G	H	(UNIT : mm)
	1.65 ±0.10	3.40 ±0.10	2.70 ±0.10	4.00 ±0.10	8.00 ±0.20	4.00 ±0.10	1.55 ±0.10	1.75 ±0.10	

REMARK :

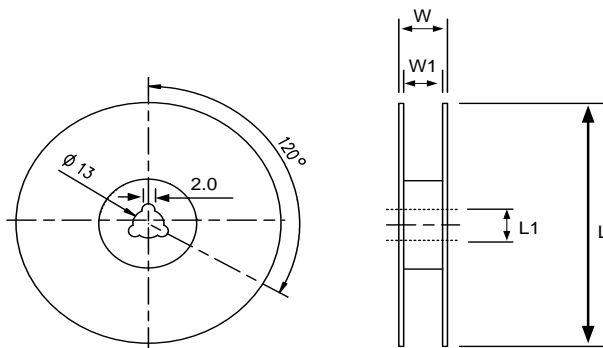
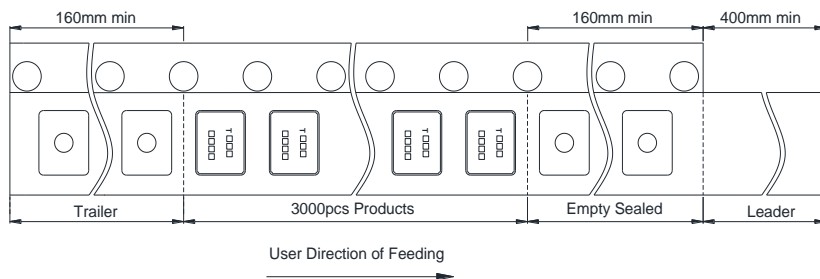

DIMENSIONS	L	L1	W	W1	(UNIT : mm)
	178±1.00	13±0.50	11.5±0.20	8±0.10	

PACKING

Box Item:

- 1. Reel X 6 (L200 X W200 X H140mm)
- 2. Reel X 12 (L200 X W200 X H250mm)
- 3. Reel X 25 (L400 X W400 X H280mm)
- 4. Reel X 50 (L400 X W400 X H280mm)
- 5. Reel X 100 (L399 X W346 X H360mm)

Note:

- 1. For the maximum reel of loads for each type box.
- 2. The number of reels is slightly adjusted according to each

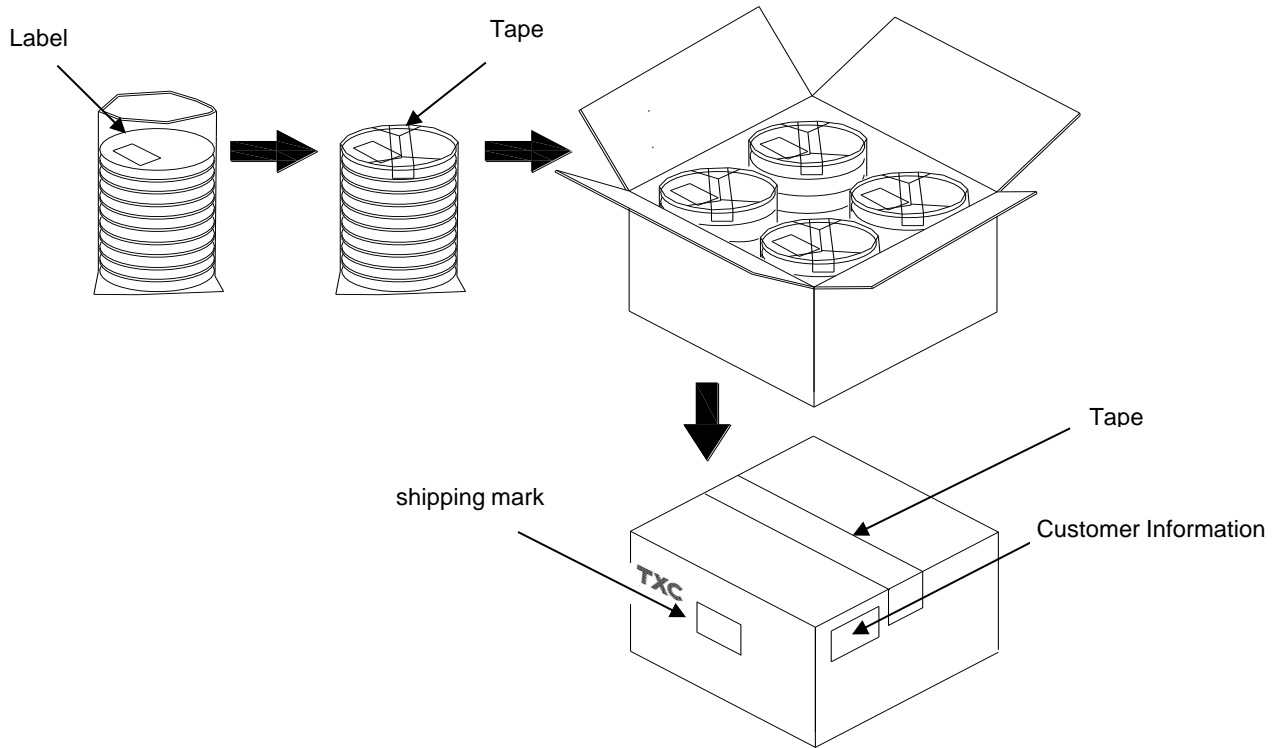

Label :

TXC CORPORATION		QA PASS
DATE CODE:		Q' TY:
LOT NO:		
PART NO:		<div style="border: 1px solid black; padding: 2px; display: inline-block;">RoHS</div> <div style="border: 1px solid black; padding: 2px; display: inline-block;">HF</div>
FREQ:		

[STORAGE]

- 1. Do not get wet by the rain.
- 2. The storage environment shall be 5°C ~40°C and 30% ~ 75%RH humidity and avoid exposure to sunlight.
- 3. If customers have special requirements, we can coordinate.

RELIABILITY SPECIFICATIONS (AEC-Q200 Compliant)
1. Mechanical Endurance

No.	Test Item	Test Methods	Test Criteria
1.1	Mechanical Shock	2000 G , 0.3 m Sec. ,3 times for all 3 directions.	B C
1.2	Vibration	Frequency range 10 ~ 2000 Hz Acceleration 20G Amplitude 1.52mm Sweep time 20 minute Pencil axes each test time 4 hours (Total test time 12 hours)	B C
1.3	Terminal Strength	17.7N force for 60sec +/-1sec.	F
1.4	Board Flex	Duration time:60 Sec Minimum,Deviation:3mm	B C
1.5	Solderability	Temperature 245 °C +/- 5°C Immersing depth 0.5 mm minimum Immersion time 5 +/- 0.5 seconds Flux Rosin resin methyl alcohol solvent (1 : 4)	E

2. Environmental Endurance

No.	Test Item	Test Methods	SPEC
2.1	Resistance To Soldering Heat	Test temperature 260 +/- 5 °C Test time 10 +/- 1 sec.	BCD
2.2	High Temp. Storage	+ 125°C ± 3 °C for 1000 ± 12 Hrs	BCD
2.3	Low Temp. Storage	- 40 °C ± 3 °C for 1000 ± 12 Hrs	BCD
2.4	Temperature cycle	-55°C ~125°C, for 1000 cycles. 	BCD
2.5	Operational Life	1000 hrs @ 125± 3°C. Rated VDD applied with 1 MΩ.	BCD
2.6	Biased Humidity	85°C ± 3°C , RH 85% , 1000 Hrs	BCD

RELIABILITY SPECIFICATIONS

Specifications	
A	Frequency change: Within ± 5 ppm or in customer's specification.
B	Frequency change: Within ± 10 ppm or in customer's specification.
C	Equivalent series resistance(E.S.R) change: Within $\pm 15\%$ or 10Ω (larger value).
D	After conditioning , quartz crystal units shall be subjected to standard atmospheric conditions for 24 hour, and measured.
E	Minimum 95% of immersed terminal shall be covered with new uniform solder.
F	No damage on specimen

Measurement condition

Electrical characteristics measured by S&A250B or equivalent.

单击下面可查看定价，库存，交付和生命周期等信息

[>>TXC\(台湾晶技\)](#)