

**FEATURES**

- z Simple low parts count
- z Internal 32V NDMOS switch
- z Up to 1.4A output current
- z Single pin on/off and brightness control using DC voltage or PWM
- z Soft Start
- z High efficiency (up to 97%)
- z Wide input voltage range: 6V to 32V
- z Output shutdown
- z Up to 1MHz switching frequency
- z Inherent open-circuit LED protection
- z Typical 4% output current accuracy
- z High-side current sense
- z Hysteretic control: no compensation
- z Adjustable constant LED current
- z Over temperature protection
- z Pb-free SOT89-5 packages

**APPLICATIONS**

- z Low voltage halogen replacement LEDs
- z Automotive lighting
- z Low voltage industrial lighting
- z LED back-up lighting
- z Illuminated signs
- z LCD TV backlighting

**DESCRIPTION**

The BL9582B is a continuous mode inductive step-down converter, designed for driving single or multiple series connected LEDs efficiently from a voltage source higher than the LED voltage. The device operates from an input supply between 6V and 32V and provides an externally output current up to 1.4A. Depending upon supply voltage and external components, this can provides up to 24 watts of output power.

The BL9582B includes the output switch and a high-side output current sensing circuit, which uses an external resistor to set the nominal average output current.

Output current can be adjusted by applying an external control signal to the 'ADJ' pin. The ADJ pin will accept either a DC voltage or a PWM waveform. During DC dimming, this will provide a continuous output current that is proportional to the external applied DC voltage. During the PWM dimming, this will provide a gated output current and the average current is proportional to the duty cycle. Applying a voltage of 0.2V or lower to the ADJ pin turns the output off and switches the device into a low current standby state.

**ORDERING INFORMATION**

BL9582B X XXX

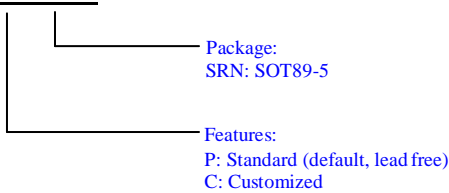

**TYPICAL APPLICATION**

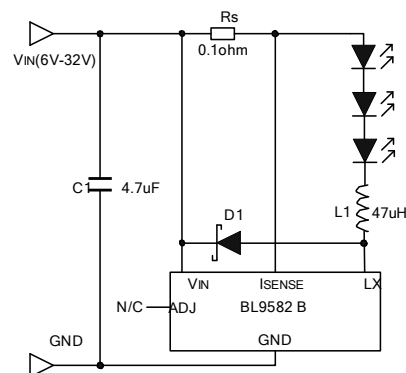

## Absolute Maximum Rating <sup>(Note 1)</sup> Input

Supply Voltage ( $V_{IN}$ )	-0.3V to +40V	Maximum Junction Temperature	150°C
$I_{SENSE}$ Voltage ( $V_{ISENSE}$ )	+0.3V to -5V <sup>(Note 2)</sup>	Operating Temperature Range <sup>(Note 3)</sup>	-40°C to 125°C
LX Output Voltage ( $V_{LX}$ )	-0.3V to +40V	Storage Temperature Range	-55°C to 150°C
Adjust Pin Input Voltage ( $V_{ADJ}$ )	-0.3V to +6V	Lead Temperature (Soldering, 10s)	300°C
Switch Output Current ( $I_{LX}$ )	1.7A		

## Package Information

<p style="text-align: center;">SOT89-5 TOP VIEW</p>		
Part Number	Top Mark	Temp Range
BL9582B	BL9582B(Note 4) A Y W W	-40°C to +125°C

## Thermal Resistance <sup>(Note 5)</sup>:

Package	$\Theta_{JA}$	$\Theta_{JC}$
SOT89-5	160 °C/W	45°C/W

**Note 1:** Absolute Maximum Ratings are those values beyond which the life of a device may be impaired.

**Note 2:**  $V_{ISENSE}$  measured respect to  $V_{IN}$

**Note 3:** The BL9582B is guaranteed to meet performance specifications from 0°C to 70°C. Specifications over the -40°C to 125°C operating temperature range are assured by design, characterization and correlation with statistical process controls.

**Note 4:** The first row printed BL9582B, the second row printed A Y W W. Y: Year of wafer manufacturing W: Week of wafer manufacturing.

Y	9	A	B	C	D
Year	2009	2010	2011	2012	2013

W W	01	...	26	27	28	...	53	54
Week	1	...	26	27	28	...	53	54

**Note 5:** Thermal Resistance is specified with approximately 1 square of 1 oz copper.

Pin Description

PIN	NAME	FUNCTION
1	LX	Drain of NDMOS switch
2	GND	Ground (0V)
3	ADJ	Multi-function On/Off and brightness control pin: <ul style="list-style-type: none"> <li>• Leave floating for normal operation.</li> <li>• Drive to voltage below 0.2V to turn off output current</li> <li>• Drive with DC voltage (<math>0.3V &lt; V_{ADJ} &lt; 1.2V</math>) to adjust output current from 25% to 100% of <math>I_{OUTnom}</math>. If the ADJ voltage is larger than 1.2V, the output current is <math>I_{OUTnom}</math>.</li> <li>• Drive with PWM signal from open-collector or open-drain transistor, to adjust output current.</li> <li>• Connect a capacitor from this pin to ground to activate soft-start. (soft-start time is approx. <math>0.06ms/nF</math>)</li> </ul>
4	$I_{SENSE}$	Connect resistor $R_S$ from this pin to $V_{IN}$ to define nominal average output current $I_{OUTnom}=0.1/R_S$
5	$V_{IN}$	Input voltage (6V to 32V). Decouple to ground with 4.7uF or higher X7R ceramic capacitor close to device

Block Diagram

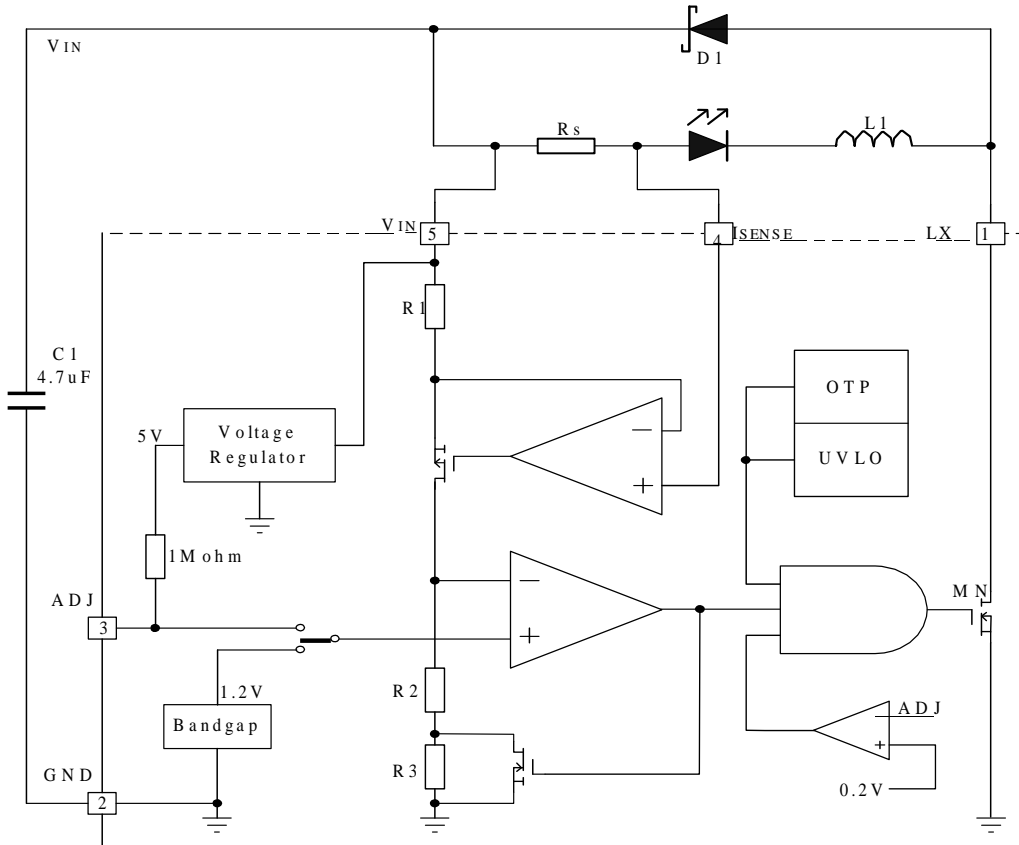

## Electrical Characteristics (Note 6)

(Test conditions:  $V_{IN}=12V$ ,  $T_A=25^{\circ}C$ , unless otherwise noted.)

Symbol	Parameter	Conditions	MIN	TYP	MAX	Unit
$V_{IN}$	Input voltage		6		32	V
$V_{UVLO}$	Under voltage lock out	$V_{IN}$ Rising		5.07		V
$V_{UVLO(HYS)}$	UVLO hysteresis	$V_{IN}$ falling		4.87		V
$I_{Q(OFF)}$	Quiescent supply current with output off	ADJ Pin grounded		100		$\mu A$
$I_{Q(ON)}$	Quiescent supply current with output switching	ADJ Pin floating $f=250KHz$		1.8	50	mA
$V_{ISENSE}$	Mean current sense threshold voltage	Measure on $I_{SENSE}$ pin with respect to $V_{IN}$	96	100	104	mV
$V_{SENSE(HYS)}$	Sense threshold hysteresis			$\pm 15$		%
$I_{SENSE}$	$I_{SENSE}$ pin input current	$V_{ISENSE}=V_{IN}-0.1$		1.2	10	$\mu A$
$V_{ADJ}$	ADJ pin floating voltage	ADJ pin floating		4		V
$I_{ADJ}$	ADJ pin leakage current	ADJ pin grounded		5		$\mu A$
$R_{ADJ}$	ADJ pin pull up resistor to internal supply voltage			1		$M\Omega$
$V_{ADJ(OFF)}$	DC voltage on ADJ pin to switch device from active (on) state to quiescent (off) state	$V_{ADJ}$ falling .	0.15	0.2	0.25	V
$V_{ADJ(ON)}$	DC voltage on ADJ pin to switch device from quiescent (off) state to active (on) state	$V_{ADJ}$ rising	0.2	0.25	0.3	V
$V_{ADJ(H)}$	Digital dimming ADJ pin input voltage high		1.5			V
$V_{ADJ(L)}$	Digital dimming ADJ pin input voltage low				0.2	V
$V_{ADJ(DC)}$	DC brightness control		0.3		1.2	V
$f_{ADJ}$	Recommended Digital dimming frequency		0.1		20	kHz
$D_{PWM(LF)}$	Duty cycle range of PWM signal applied to ADJ pin during low frequency PWM dimming mode	$f_{ADJ}=100Hz$	0.1		100	%
	Brightness control range			1000:1		
$D_{PWM(HF)}$	Duty cycle range of PWM signal applied to ADJ pin during high frequency PWM dimming mode	$f_{ADJ}=10KHz$	5		100	%
	Brightness control range			20:1		
$R_{LX}$	LX switch on resistance			0.35	0.7	$\Omega$
$I_{LX(LEAK)}$	LX switch leakage			0.1	5	$\mu A$

**Electrical Characteristics (continued)**(Test conditions:  $V_{IN}=12V$ ,  $T_A=25^{\circ}C$ , unless otherwise noted.)

Symbol	Parameter	Conditions	MIN	TYP	MAX	Unit
$I_{LX(MEAN)}$	Continuous LX switch current				1.4	A
$T_{EN, DELAY}$	Chip enable delay time	The delay time between ADJ pin rising edge and LX pin falling edge		480		ns
$T_{ENB, DELAY}$	Chip disable delay time	The delay time between ADJ pin falling edge and LX pin rising edge		25		ns
$f_{LX(MAX)}$	Recommended maximum operating frequency				1	MHz
$T_{OTP}$	Over temperature protection threshold	Temperature rising		160		$^{\circ}C$
$T_{SD(HYS)}$	Over temperature protection hysteresis	Temperature falling		20		$^{\circ}C$

**Note 6:** 100% production test at  $+25^{\circ}C$ . Specifications over the temperature range are guaranteed by design and characterization.

### Typical Performance Characteristics

(Test conditions:  $V_{IN}=12V$ ,  $R_S=0.1\Omega$ ,  $T_A=25^\circ C$ , unless otherwise noted.)

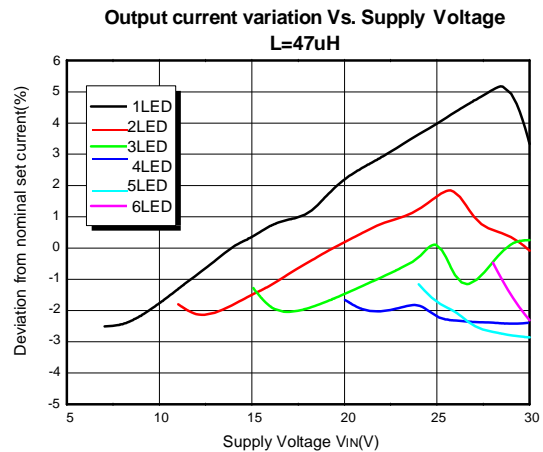
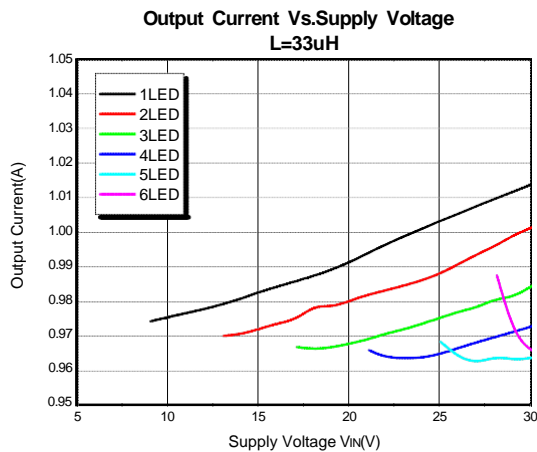
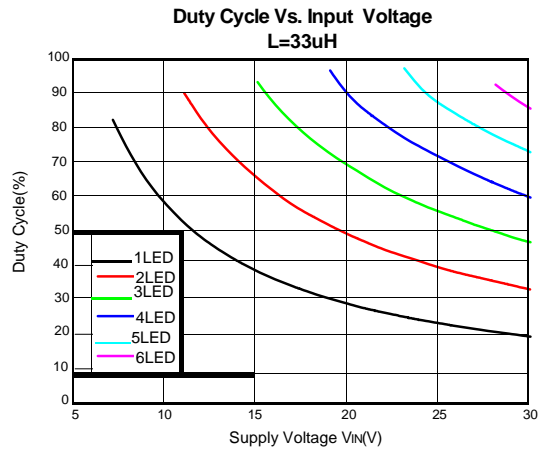
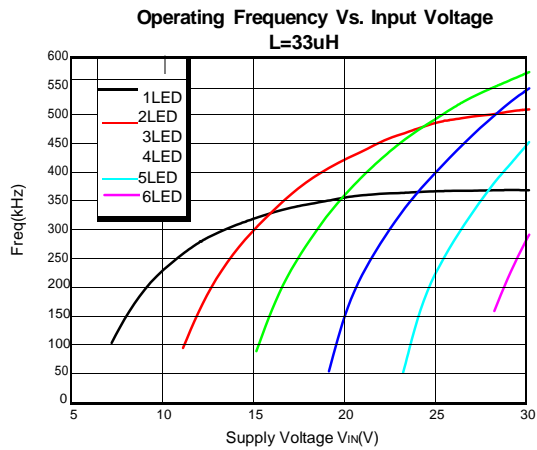
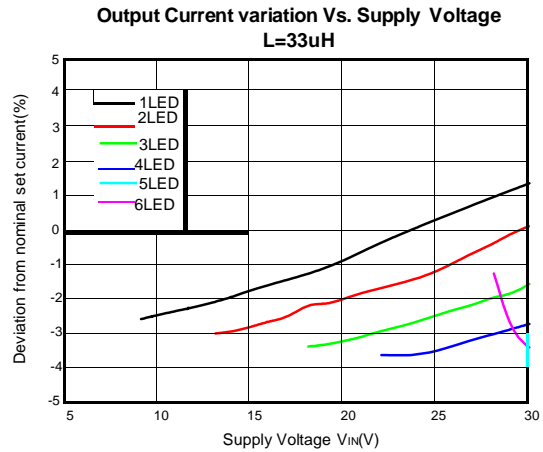
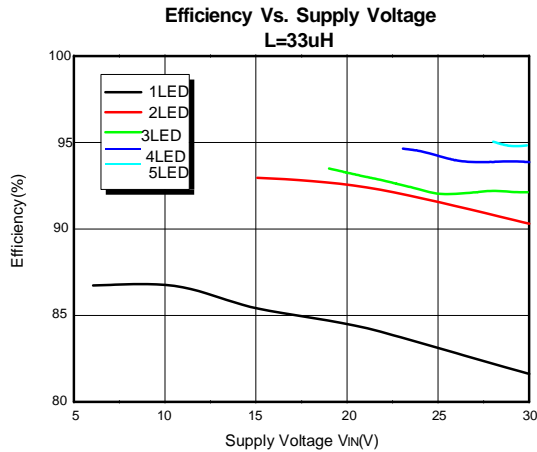

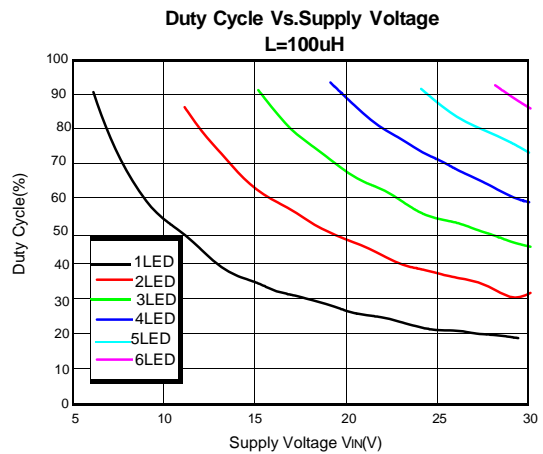
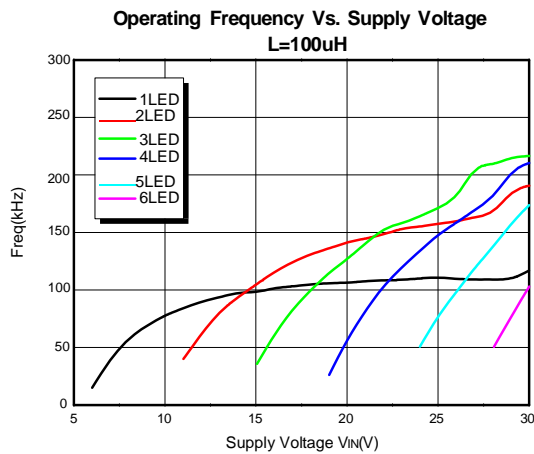
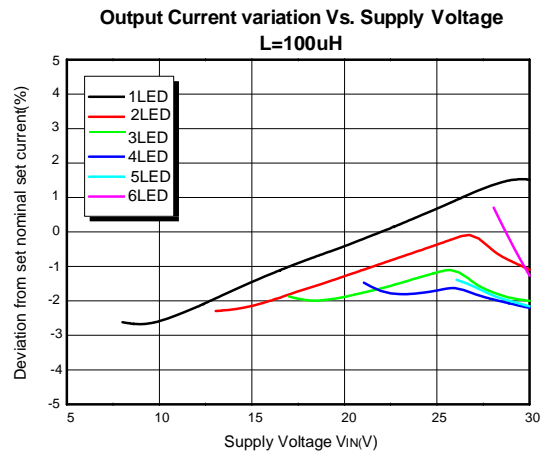
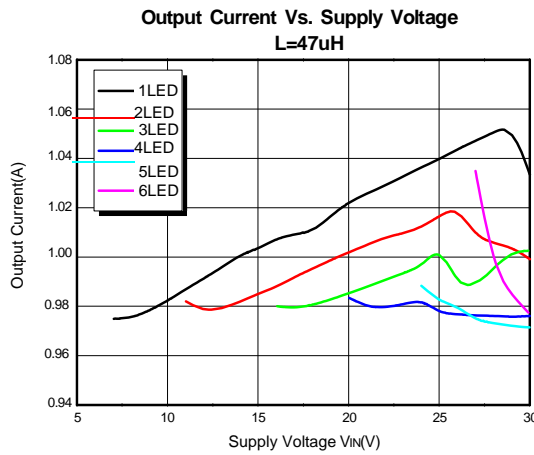
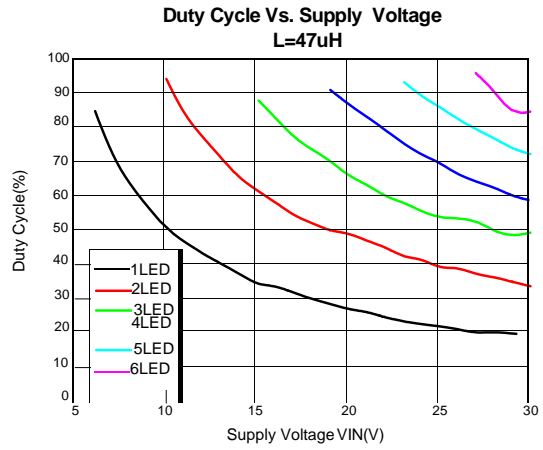
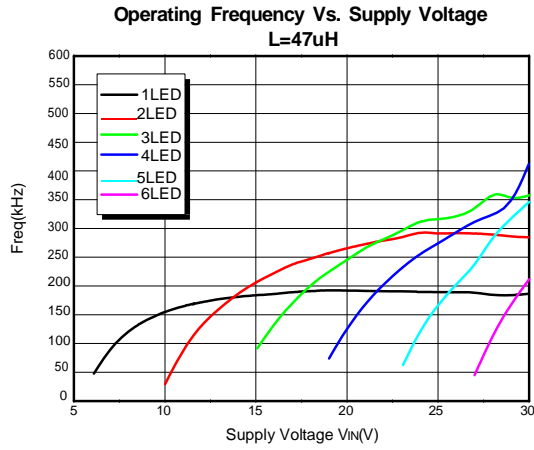

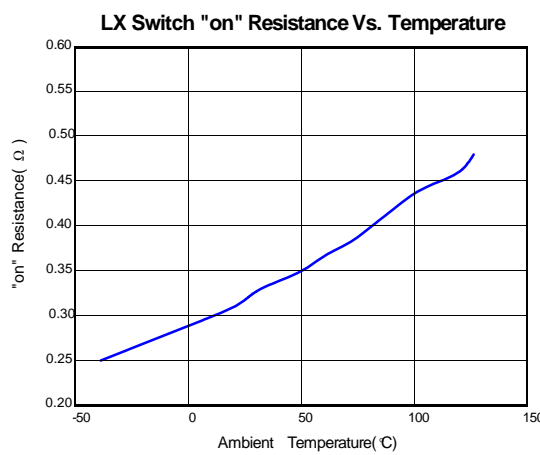
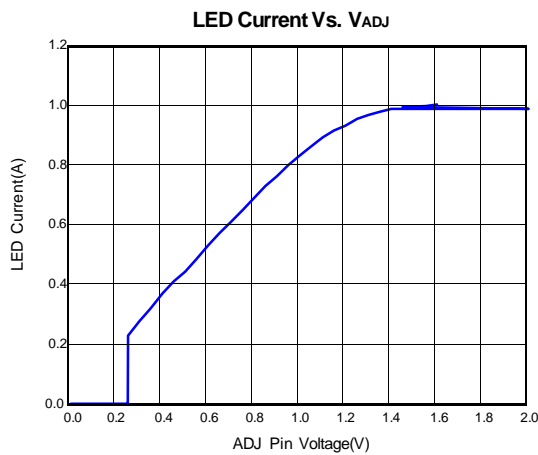
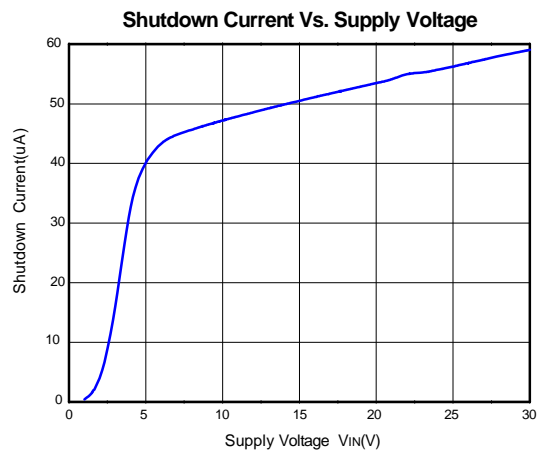
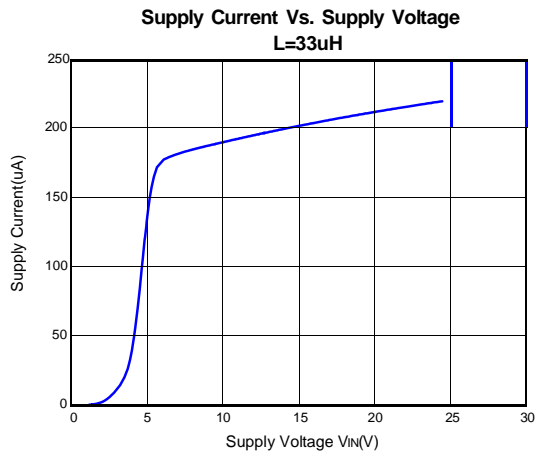
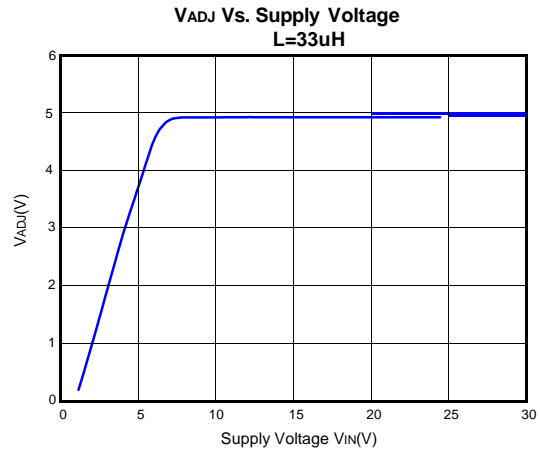
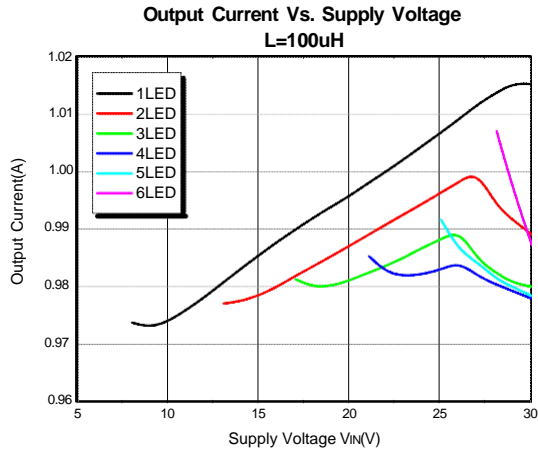



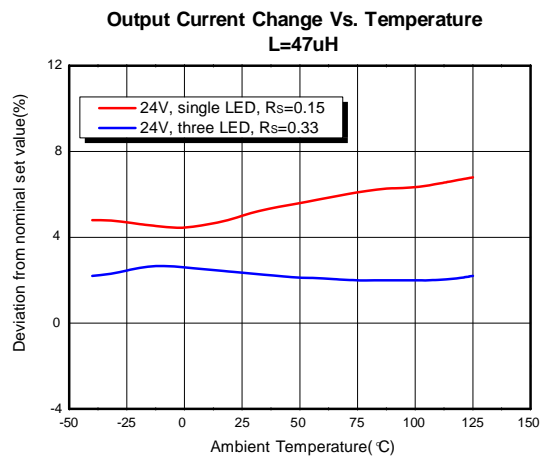
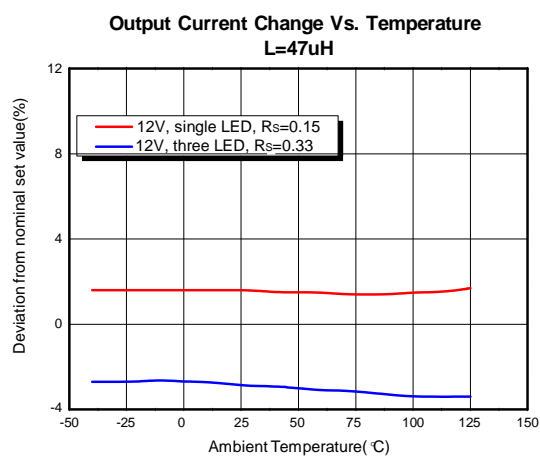
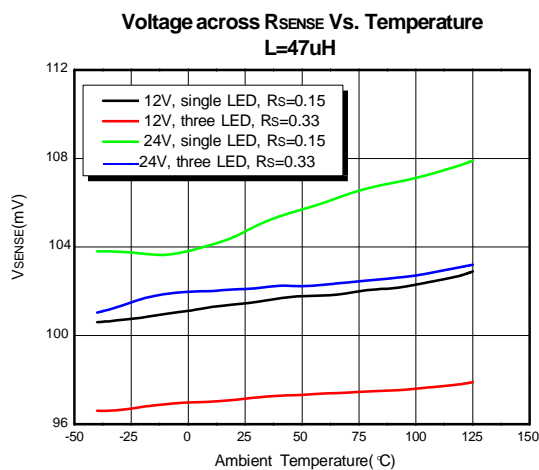
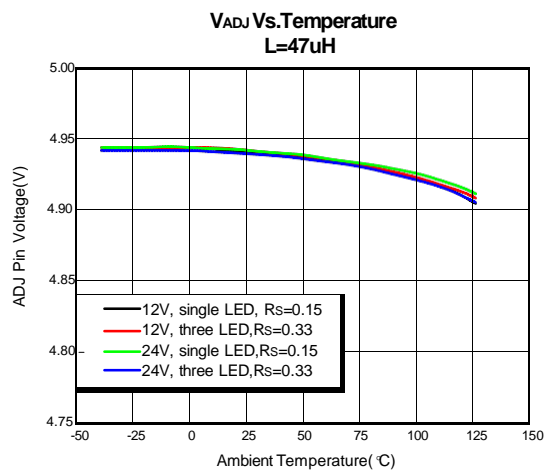

## Operation Description

The device, in conjunction with the coil (L1) and current sense resistor (R<sub>S</sub>), forms a self oscillating continuous-mode buck converter. When input voltage V<sub>IN</sub> is first applied, the initial current in L1 and R<sub>S</sub> is zero and there is no output from the current sense circuit. Under this condition, the (-) input to the comparator is at ground and its output is high. This turns on an internal switch and switches the LX pin low, causing current to flow from V<sub>IN</sub> to ground, via R<sub>S</sub>, L1 and the LED(s). The current rises at a rate determined by V<sub>IN</sub> and L1 to produce a voltage ramp (V<sub>ISENSE</sub>) across R<sub>S</sub>. When (V<sub>IN</sub>-V<sub>ISENSE</sub>) > 115mV, the output of comparator switches low and the switch turns off. The current flowing on the R<sub>S</sub> decreases at another rate. When (V<sub>IN</sub>-V<sub>ISENSE</sub>) < 85mV, the switch turns on again and the mean current on the LED is determined by

$$\left(\frac{85+115}{2}\right)mV / R_s = 100mV / R_s$$

The high-side current-sensing scheme and on-board current-setting circuitry minimize the number of external components while delivering LED current with ±4% accuracy, using a 1% sense resistor.

The BL9582B allows dimming with a PWM signal at the ADJ input. A logic level below 0.2V at ADJ forces BL9582B to turn off the LED and the logic level at ADJ must be at least 1.2V (1.5V recommended) to turn on the full LED current. The frequency of PWM dimming ranges from 100Hz to more than 20 kHz.

The ADJ pin can be driven by an external DC voltage (V<sub>ADJ</sub>) to adjust the output current to a value below the nominal

average value defined by R<sub>S</sub>. The DC voltage is valid from 0.3V to 1.2V. When the dc voltage is higher than 1.2V, the output current keeps constant. The LED current also can be adjusted by a resistor connected to the ADJ pin. An internal pull-up resistor (typical 1.0 MΩ) is connected to a 5V internal regulator. The voltage of ADJ pin is divided by the internal and external resistor. The ADJ pin is pulled up to the internal regulator (5V) by a 1.0 MΩ resistor. It can be floated at normal working. When a voltage applied to ADJ falls below the threshold (0.2V nom.), the output switch is turned off. The internal regulator and voltage reference remain powered during shutdown to provide the reference for the shutdown circuit. Quiescent supply current during shutdown is nominally 50uA and switch leakage is below 5uA. Additionally, to ensure the reliability, the BL9582B is built with a thermal shutdown (TSD) protection and a thermal pad. The TSD protects the IC from over temperature (160°C). Also the thermal pad enhances power dissipation. As a result, the BL9582B can handle a large amount of current safely.

## Application Information

### Setting nominal average output current with external resistor R<sub>S</sub>

The nominal average output current in the LED(s) is determined by the value of the external current sense resistor (R<sub>S</sub>) connected between V<sub>IN</sub> and I<sub>SENSE</sub> and is given by:

$$I_{out} = \frac{0.1}{R_s}$$

This equation is valid when ADJ pin is float

or applied with a voltage higher than 1.2V (must be less than or equal to 5V). Actually,  $R_s$  sets the maximum average current which can be adjusted to a less one by dimming.

The table below gives values of nominal average output current for several preferred values of current setting resistor ( $R_s$ ) in the typical application circuit shown on page 1.

Nominal average output current (mA)	$R_s(\Omega)$
1000	0.1
760	0.13
667	0.15
333	0.3

### Output current adjustment by external DC control

The ADJ pin can be driven by an external dc voltage ( $V_{ADJ}$ ), as shown, to adjust the output current to a value below the nominal average value defined by  $R_s$ .

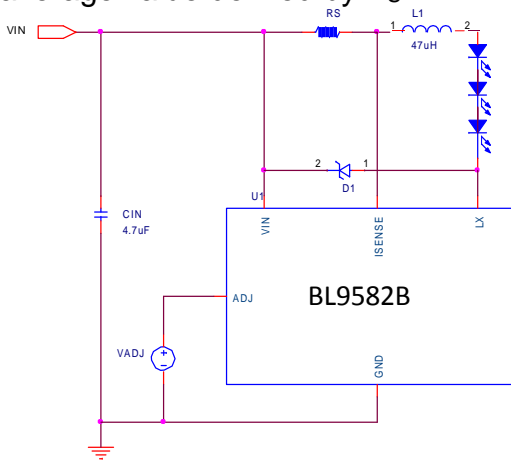

The average output current is given by:

$$I_{OUT} = \frac{0.1 \times V_{ADJ}}{1.2 \times R_s} (0.3V \leq V_{ADJ} \leq 1.2V)$$

Note that 100% brightness setting corresponds to:  $(1.3V \leq V_{ADJ} \leq 5V)$

### Output current adjustment by PWM

### control

A Pulse Width Modulated (PWM) signal with duty cycle PWM can be applied to the ADJ pin, as shown below, to adjust the output current to a value below the nominal average value set by resistor  $R_s$ :

$$I_{OUT} = \frac{0.1 \times D}{R_s} (0 \leq D \leq 100\%, 1.2V \leq V_{ADJ} \leq 5V)$$

$$I_{OUT} = \frac{V_{PULSE} \times 0.1 \times D}{1.2 \times R_s} (0 \leq D \leq 100\%, 0.3V \leq V_{PULSE} \leq 1.2V)$$

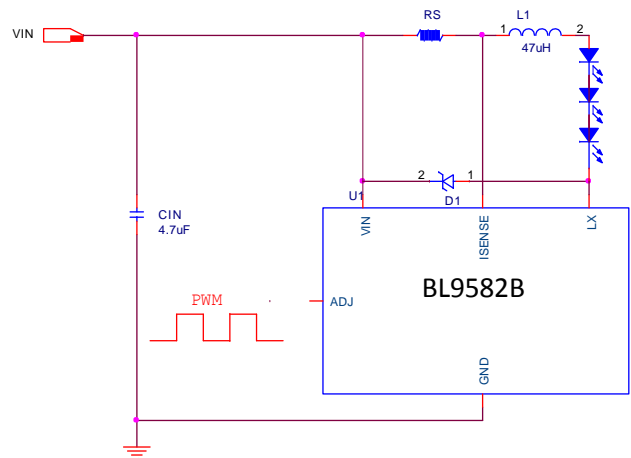

PWM dimming provides reduced brightness by modulating the LED's forward current between 0% and 100%. The LED brightness is controlled by adjusting the relative ratios of the on time to the off time. A 25% brightness level is achieved by turning the LED on at full current for 25% of one cycle. To ensure this switching process between on and off state is invisible by human eyes, the switching frequency must be greater than 100 Hz. Above 100 Hz, the human eyes average the on and off times, seeing only an effective brightness that is proportional to the LED's on-time duty cycle. The advantage of PWM dimming is that the forward current is always constant,

therefore the LED color does not vary with brightness as it does with analog dimming. Pulsing the current provides precise brightness control while preserving the color purity. The dimming frequency of BL9582B can be as high as 20 kHz.

### Shutdown mode

Taking the ADJ pin to a voltage below 0.2V will turn off the output and the supply current will fall to a low standby level of 50 $\mu$ A nominal.

### Soft-start

An external capacitor from the ADJ pin to ground will provide soft-start delay, by increasing the time taken for the voltage on this pin to rise to the turn-on threshold. Adding capacitance increases this delay by approximately 0.06ms/nF.

### Inherent open-circuit LED protection

If the connection to the LED(s) is open-circuited, the coil is isolated from the LX pin of the chip, so the device will not be damaged.

### Capacitor selection

A low ESR capacitor should be used for input decoupling, as the ESR of this capacitor appears in series with the supply source impedance and lowers overall efficiency. This capacitor has to supply the relatively high peak current to the coil and smooth the current ripple on the input supply. A minimum value of 4.7 $\mu$ F is acceptable if the input source is close to the device, but higher values will improve performance at lower input voltages, especially when the source impedance is high. The input capacitor should be placed

as close as possible to the IC.

For maximum stability over temperature and voltage, capacitors with X7R, X5R, or better dielectric are recommended. Capacitors with Y5V dielectric are not suitable for decoupling in this application and should not be used. A suitable Murata capacitor would be GRM42-2X7R475K-50. The following web sites are useful when finding alternatives:

[www.murata.com](http://www.murata.com)  
[www.t-yuden.com](http://www.t-yuden.com)  
[www.avxcorp.com](http://www.avxcorp.com)

### Inductor selection

Recommended inductor values for the BL9582B are in the range 27 $\mu$ H to 100 $\mu$ H. Higher values of inductance are recommended at lower output current in order to minimize errors due to switching delays, which result in increased ripple and lower efficiency. Higher values of inductance also result in a smaller change in output current over the supply voltage range. The inductor should be mounted as close to the device as possible with low resistance connections to the LX and  $V_{IN}$  pins. The chosen coil should have a saturation current higher than the peak output current and a continuous current rating above the required mean output current. Suitable coils for use with the BL9582B are listed in the table below:

Part No.	L (uH)	DCR ( $\Omega$ )	$I_{SAT}$ (A)	Manufacturer
MSS1038-333	33	0.093	2.3	CoilCraft <a href="http://www.coilcraft.com">www.coilcraft.com</a>
MSS1038-473	47	0.128	2	
MSS1038-683	68	0.213	1.6	
MSS1038-104	100	0.304	1.3	

The inductor value should be chosen to maintain operating duty cycle and switch 'on'/'off' times within the specified limits over the supply voltage and load current range.

The following equations can be used as a guide.

LX Switch 'On' time

$$T_{ON} = \frac{L \times \Delta I}{V_{IN} - V_{LED} - I_{AVG} \times (R_S + R_L + R_{LX})}$$

LX Switch 'Off' time

$$T_{OFF} = \frac{L \times \Delta I}{V_{LED} + V_D + I_{AVG}(R_S + R_L)}$$

Where:

- L is the coil inductance (H)
- R<sub>L</sub> is the coil resistance (Ω)
- R<sub>S</sub> is the current sense resistance (Ω)
- I<sub>AVG</sub> is the required LED current (A)
- ΔI is the coil peak-peak ripple current (A) (Internally set to 0.3 x I<sub>AVG</sub>)
- V<sub>IN</sub> is the supply voltage (V)
- V<sub>LED</sub> is the total LED forward voltage (V)
- R<sub>LX</sub> is the switch resistance (Ω) (=0.35Ω nominal)
- V<sub>D</sub> is the diode forward voltage at the required load current (V)

### Diode selection

For maximum efficiency and performance, the rectifier (D1) should be a fast low capacitance Schottky diode with low reverse leakage at the maximum operating voltage and temperature. They also provide better efficiency than silicon diodes, due to a combination of lower forward voltage and reduced recovery time. It is important to select parts with a peak current rating above the peak coil current and a continuous current rating higher than

the maximum output load current. It is very important to consider the reverse leakage of the diode when operating above 85°C. Excess leakage will increase the power dissipation in the device and if close to the load may create a thermal runaway condition. The higher forward voltage and overshoot due to reverse recovery time in silicon diodes will increase the peak voltage on the LX output. If a silicon diode is used, care should be taken to ensure that the total voltage appearing on the LX pin including supply ripple, does not exceed the specified maximum value. The following web sites are useful when finding alternatives:

[www.onsemi.com](http://www.onsemi.com)

### Reducing output ripple

Peak to peak ripple current in the LED(s) can be reduced, if required, by shunting a capacitor C<sub>LED</sub> across the LED(s) as shown below:

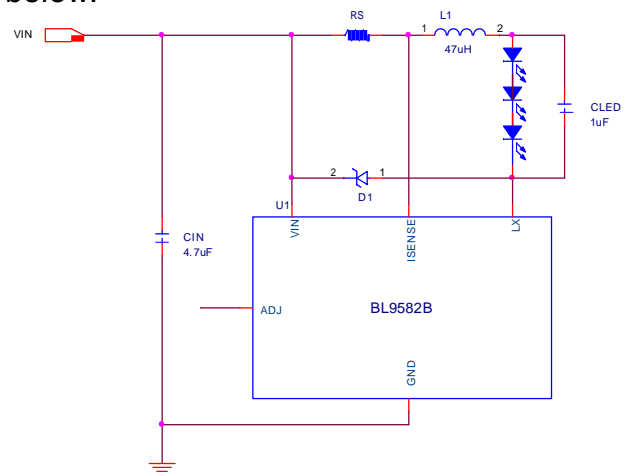

A value of 1µF will reduce the supply ripple current by a factor three (approx.). Proportionally lower ripple can be achieved with higher capacitor values. Note that the capacitor will not affect operating frequency or efficiency, but it will increase start-up delay and reduce the frequency of

dimming, by reducing the rate of rise of LED voltage. By adding this capacitor the current waveform through the LED(s) changes from a triangular ramp to a more sinusoidal version without altering the mean current value.

### Operation at low supply voltage

The internal regulator disables the drive to the switch until the supply has risen above the startup threshold ( $V_{UVLO}$ ). Above this threshold, the device will start to operate. However, with the supply voltage below the specified minimum value, the switch duty cycle will be high and the device power dissipation will be at a maximum. Care should be taken to avoid operating the device under such conditions in the application, in order to minimize the risk of exceeding the maximum allowed die temperature. (See next section on thermal considerations). The drive to the switch is turned off when the supply voltage falls below the under-voltage threshold ( $V_{UVLO}-0.2V$ ). This prevents the switch working with excessive 'on' resistance under conditions where the duty cycle is high.

### Thermal considerations

When operating the device at high ambient temperatures, or when driving maximum load current, care must be taken to avoid exceeding the package power dissipation limits. The graph below gives details for power derating. This assumes the device to be mounted on a 25mm<sup>2</sup> PCB with 1oz copper standing in still air.

Note that the device power dissipation will most often be a maximum at minimum supply voltage. It will also increase if the efficiency of the circuit is low. This may result from the use of unsuitable coils, or

excessive parasitic output capacitance on the switch output.

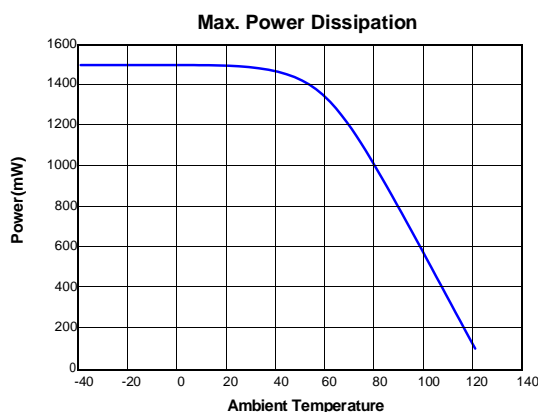

### Thermal compensation of output current

High luminance LEDs often need to be supplied with a temperature compensated current in order to maintain stable and reliable operation at all drive levels. The LEDs are usually mounted remotely from the device, so internal circuits for the BL9582B have been optimized to minimize the change in output current when no compensation is employed. If output current compensation is required, it is possible to use an external temperature sensing network - normally using Negative Temperature Coefficient (NTC) thermistors and/or diodes, mounted very close to the LED(s). The output of the sensing network can be used to drive the ADJ pin in order to reduce output current with increasing temperature.

### Thermal shutdown protection

To ensure the reliability, the BL9582B is built with a thermal shutdown (TSD) protection function. The TSD protects the IC from over temperature (160°C). When the chip



temperature decreases (140°C), the IC recovers again.

### Layout considerations

Careful PCB layout is critical to achieve low switching losses and stable operation. Use a multilayer board whenever possible for better noise immunity. Minimize ground noise by connecting high-current ground returns, the input bypass-capacitor ground lead, and the output-filter ground lead to a single point (star ground configuration).

### LX pin

The LX pin of the device is a fast switching node, so PCB tracks should be kept as short as possible. To minimize ground 'bounce', the ground pin of the device should be soldered directly to the ground plane.

### Coil and decoupling capacitors and current sense resistor

It is particularly important to mount the coil and the input decoupling capacitor as close to the device pins as possible to minimize parasitic resistance and inductance, which will degrade efficiency. It is also important to minimize any track resistance in series with current sense resistor  $R_S$ . It's best to connect  $V_{IN}$  directly to one end of  $R_S$  and  $I_{SENSE}$  directly to the opposite end of  $R_S$  with no other currents flowing in these tracks. It is important that the cathode current of the Schottky diode does not flow in a track between  $R_S$  and  $V_{IN}$  as this may give an apparent higher measure of current than is actual because of track resistance.

### ADJ pin

The ADJ pin is a high impedance input, so

when left floating, PCB traces to this pin should be as short as possible to reduce noise pickup. ADJ pin can also be connected to a voltage between 1.2V~5V. In this case, the internal circuit will clamp the output current at the value which is set by  $ADJ=1.2V$ .

### High voltage traces

Avoid running any high voltage traces close to the ADJ pin, to reduce the risk of leakage due to board contamination. Any such leakage may raise the ADJ pin voltage and cause excessive output current. A ground ring placed around the ADJ pin will minimize changes in output current under these conditions.

## Package Description

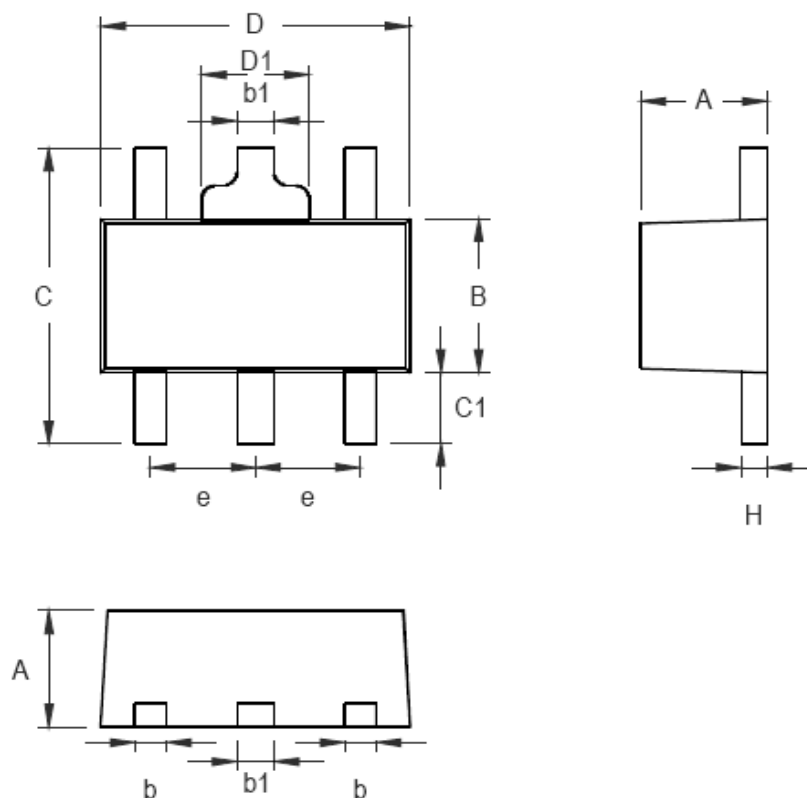

Symbol	Dimensions In Millimeters		Dimensions In Inches	
	Min	Max	Min	Max
A	1.397	1.600	0.055	0.063
b	0.356	0.508	0.014	0.020
b1	0.406	0.533	0.016	0.021
B	2.388	2.591	0.094	0.102
C	3.937	4.242	0.155	0.167
C1	0.787	1.194	0.031	0.047
D	4.394	4.597	0.173	0.181
D1	1.397	1.702	0.055	0.067
e	1.500 TYP.		0.060 TYP.	
H	0.356	0.432	0.014	0.017

SOT89-5 Surface Mount Package



单击下面可查看定价，库存，交付和生命周期等信息

[>>UDF\(优迪半导体\)](#)