

SOT-23 Plastic-Encapsulate Transistors

BC856A, B TRANSISTOR (PNP)

BC857A, B,C

BC858A, B,C

FEATURES

- Ideally suited for automatic insertion
- For Switching and AF Amplifier Applications

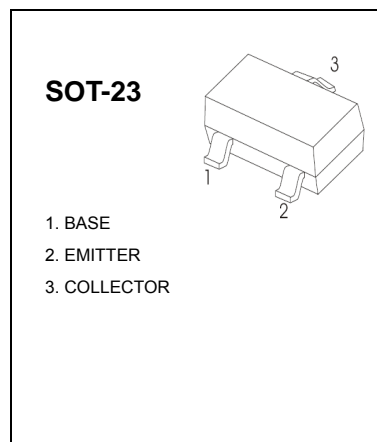

MAXIMUM RATINGS (T_a=25°C unless otherwise noted)

Symbol	Parameter	Value	Unit
V _{CB0}	Collector-Base Voltage		
	BC856	-80	V
	BC857	-50	
BC858	-30		
V _{CEO}	Collector-Emitter Voltage		
	BC856	-65	V
	BC857	-45	
BC858	-30		
V _{EB0}	Emitter-Base Voltage	-5	V
I _C	Collector Current –Continuous	-0.1	A
P _C	Collector Power Dissipation	200	mW
T _J	Junction Temperature	150	°C
T _{stg}	Storage Temperature	-65-150	°C

DEVICE MARKING

BC856A=3A; BC856B=3B;
BC857A=3E; BC857B=3F; BC857C=3G;
BC858A=3J; BC858B=3K; BC858C=3L

SOT-23 Plastic-Encapsulate Transistors
ELECTRICAL CHARACTERISTICS (T_a=25°C unless otherwise specified)

Parameter	Symbol	Test conditions	Min	Max	Unit
Collector-base breakdown voltage	BC856 BC857 BC858	V _{CBO} I _C = -10μA, I _E =0	-80 -50 -30		V
Collector-emitter breakdown voltage	BC856 BC857 BC858	V _{CEO} I _C = -10mA, I _B =0	-65 -45 -30		V
Emitter-base breakdown voltage		V _{EBO} I _E = -1μA, I _C =0	-5		V
Collector cut-off current	BC856 BC857 BC858	I _{CBO} V _{CB} = -70 V, I _E =0 V _{CB} = -45 V, I _E =0 V _{CB} = -25 V, I _E =0		-0.1	μA
Collector cut-off current	BC856 BC857 BC858	I _{CEO} V _{CE} = -60 V, I _B =0 V _{CE} = -40 V, I _B =0 V _{CE} = -25 V, I _B =0		-0.1	μA
Emitter cut-off current		I _{EBO} V _{EB} = -5 V, I _C =0		-0.1	μA
DC current gain	BC856A, 857A,858A BC856B, 857B,858B BC857C,BC858C	h _{FE} V _{CE} = -5V,I _C = -2mA	125 220 420	250 475 800	
Collector-emitter saturation voltage		V _{CE(sat)} I _C =-100mA,I _B = -5 mA		-0.5	V
Base-emitter saturation voltage		V _{BE(sat)} I _C = -100mA, I _B = -5mA		-1.1	V
Transition frequency		f _T V _{CE} = -5 V, I _C = -10mA f=100MHz	100		MHz
Collector capacitance		C _{ob} V _{CB} =-10V, f=1MHz		4.5	pF

SOT-23 Plastic-Encapsulate Transistors

Typical Characteristics BC856/BC857/BC858

Static Characteristic

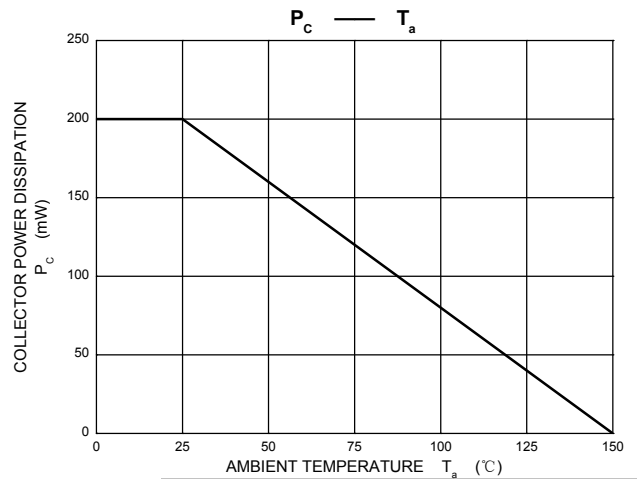
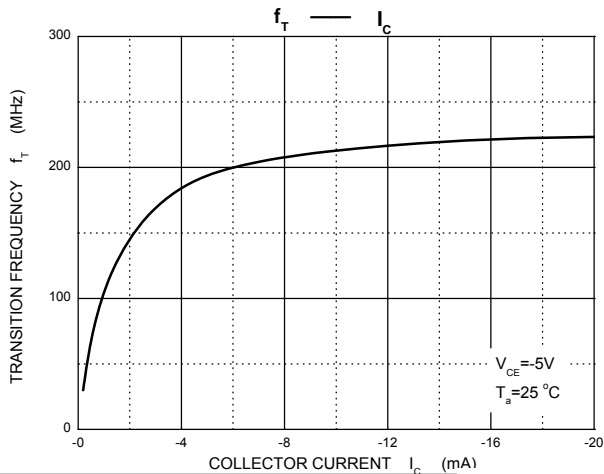
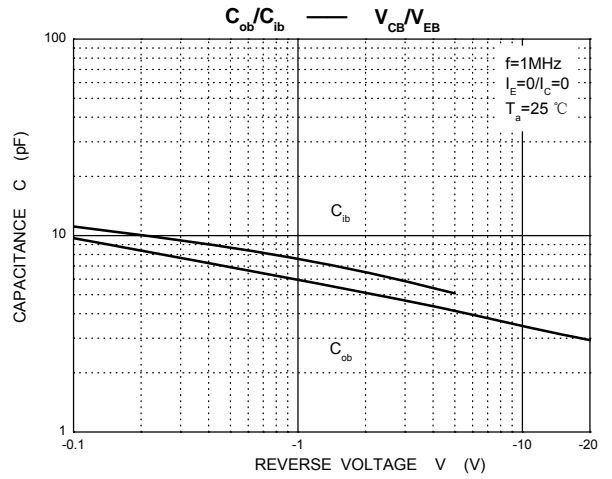
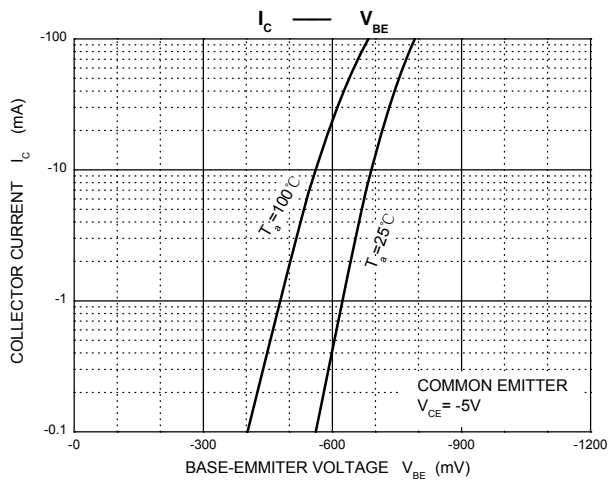
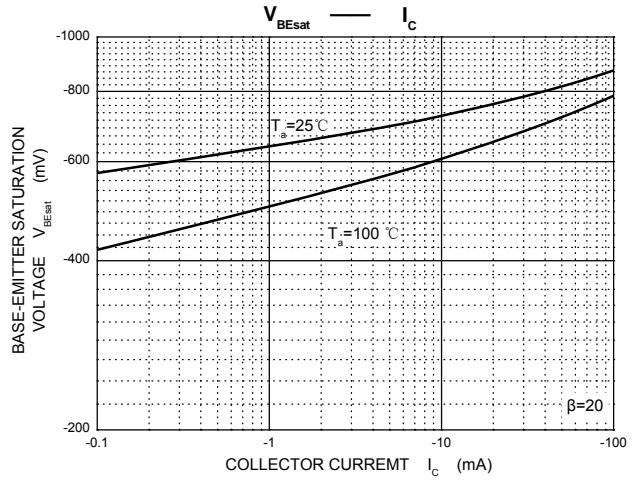
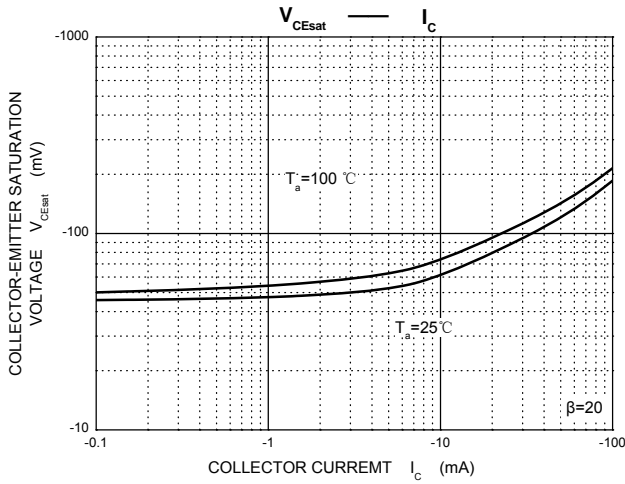
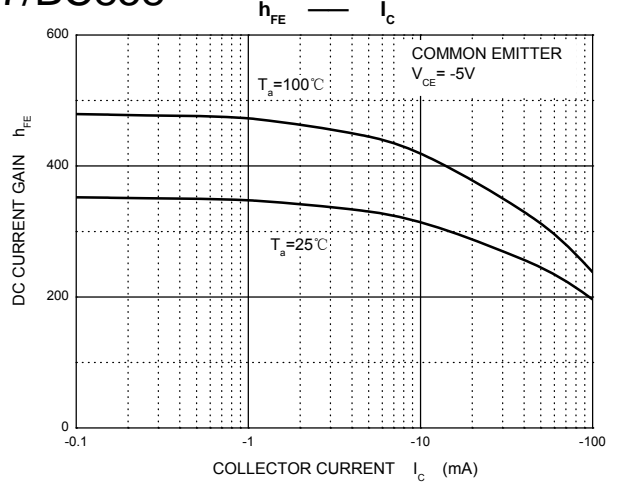
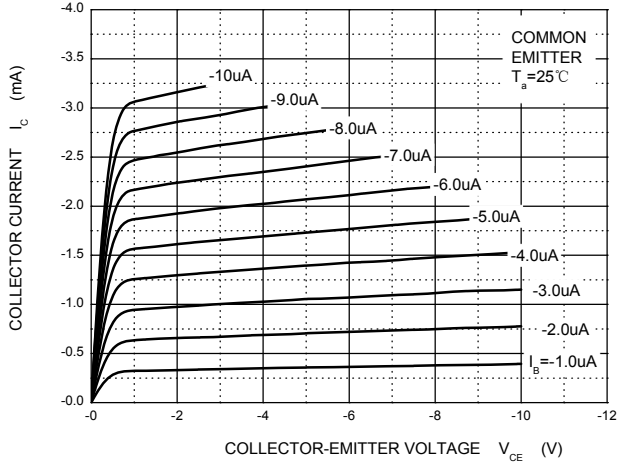

单击下面可查看定价，库存，交付和生命周期等信息

[>>UMW\(友台半导体\)](#)