

Description

The 6N138 and 6N139 series combine an AlGaAs infrared emitting diode as the emitter which is optically coupled to a silicon high speed photo darlington transistor in a plastic DIP8 package with different lead forming options.

A separate design between photodiode and darlington transistor reduces the base-collector capacitance of the input transistor which improves the speed by several orders of magnitude over conventional phototransistor optocouplers.

Features

- High isolation 5000 VRMS
- DC input with transistor output
- Operating temperature range - 55 °C to 100 °C
- REACH compliance
- Halogen free (Optional)
- MSL class 1

Truth Table (Positive Logic)

Input	Enable	Output
H	H	L
L	H	H
H	L	H
L	L	H
H	NC	L
L	NC	H

Applications

- Low current line receivers
- Current loop receivers
- Out interface to CMOS-LSTTL-TTL
- Pulse transformer replacement
- Computer-peripheral interface

Package Outlines

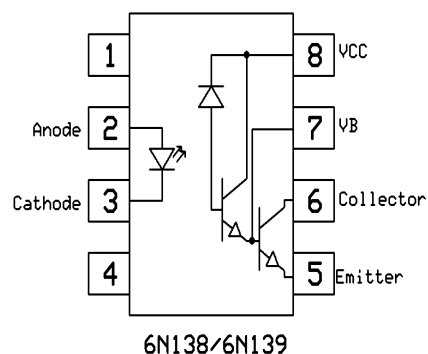

ABSOLUTE MAXIMUM RATINGS				
PARAMETER	SYMBOL	VALUE	UNIT	Note
INPUT				
Forward Current	I_F	25	mA	
Peak Forward Current	I_{FP}	50	mA	1
Peak Transient Current	$I_{F(trans)}$	1	A	2
Reverse Voltage	V_R	5	V	
Input Power Dissipation	P_I	100	mW	
OUTPUT				
Supply Voltage	V_{CC}	-0.5~18	V	
Output Voltage	V_O	-0.5~18	V	
Output Current	I_o	60	mA	
Emitter-Base Reverse Voltage	V_{EBR}	0.5	V	
Output Power Dissipation	P_O	100	mW	
COMMON				
Total Power Dissipation	P_{tot}	200	mW	
Isolation Voltage	V_{iso}	5000	V _{rms}	3
Operating Temperature	T_{opr}	-55~100	°C	
Storage Temperature	T_{stg}	-55~150	°C	
Soldering Temperature	T_{sol}	260	°C	4

Note 1. 50% duty, 1ms P.W

Note 2. $\leq 1\mu s$ P.W,300pps

Note 3. AC For 1 Minute, R.H. = 40 ~ 60%

Note 4. For 10 seconds

ELECTRICAL OPTICAL CHARACTERISTICS								
PARAMETER	SYMBOL	MIN	TYP	MAX	UNIT	TEST CONDITION	NOTE	
INPUT(at Ta=0 to 70°C , unless specified otherwise)								
Forward Voltage	V _F	-	1.28	1.7	V	I _F =1.6mA		
Reverse Current	I _R	-	-	10	μA	V _R =5V		
Input Capacitance	C _{in}	-	60	-	pF	V=0, f=1MHz		
OUTPUT(at Ta=0 to 70°C , unless specified otherwise)								
High Level Supply Current	I _{CCH}	-	0.05	10	μA	I _F =0mA, V _O =Open, V _{CC} =18V		
Low Level Supply Current	I _{CCL}	-	0.6	1.5	mA	I _F =1.6mA, V _O =Open, V _{CC} =18V		
Logic High Output Current	6N138	I _{OH}	-	0.01	100	μA	I _F =0mA, V _O =V _{CC} =18V,	
	6N139		-	-	250	μA		
TRANSFER CHARACTERISTICS(at Ta=0 to 70°C , unless specified otherwise)								
Current Transfer Ratio	6N139	CTR	400	2500	-	%	I _F = 0.5mA, V _O = 0.4V, V _{CC} =4.5V	
			500	2600	-		I _F = 1.6mA, V _O = 0.4V, V _{CC} =4.5V	
	6N138		300	2600	-			
Logic Low Output Voltage	6N139	V _{OL}	-	0.04	0.4	V	I _F = 0.5mA, I _O = 2mA, V _{CC} =4.5V	
			-	0.07	0.4		I _F = 1.6mA, I _O = 8mA, V _{CC} =4.5V	
			-	0.11	0.4		I _F = 5mA, I _O = 15mA, V _{CC} =4.5V	
			-	0.15	0.4		I _F = 12mA, I _O = 24mA, V _{CC} =4.5V	
	6N138		-	0.05	0.4		I _F = 1.6mA, I _O = 4.8mA, V _{CC} =4.5V	
Isolation Resistance	R _{iso}	10 ¹²	10 ¹⁴	-	Ω	DC500V, 40 ~ 60% R.H.		
Floating Capacitance	C _{IO}	-	0.3	1	pF	V=0, f=1MHz		

ELECTRICAL OPTICAL CHARACTERISTICS

PARAMETER	SYMBOL	MIN	TYP	MAX	UNIT	TEST CONDITION	NOTE
TRANSFER CHARACTERISTICS(at Ta=0 to 70°C , unless specified otherwise)							
Current Transfer Ratio	6N139	CTR	400	2500	-	%	$I_F = 0.5\text{mA}, V_O = 0.4\text{V}, V_{CC}=4.5\text{V}$
			500	2600	-		$I_F = 1.6\text{mA}, V_O = 0.4\text{V}, V_{CC}=4.5\text{V}$
	6N138	300	2600	-	$I_F = 1.6\text{mA}, V_O = 0.4\text{V}, V_{CC}=4.5\text{V}$		
Logic Low Output Voltage	6N139	V _{OL}	-	0.04	0.4	V	$I_F = 0.5\text{mA}, I_O = 2\text{mA}, V_{CC}=5\text{V}$
			-	0.07	0.4		$I_F = 1.6\text{mA}, I_O = 8\text{mA}, V_{CC}=4.5\text{V}$
			-	0.11	0.4		$I_F = 5\text{mA}, I_O = 15\text{mA}, V_{CC}=4.5\text{V}$
			-	0.15	0.4		$I_F = 12\text{mA}, I_O = 24\text{mA}, V_{CC}=4.5\text{V}$
	6N138	-	0.05	0.4	$I_F = 1.6\text{mA}, I_O = 4.8\text{mA}, V_{CC}=4.5\text{V}$		
Isolation Resistance	Riso	10 ¹²	10 ¹⁴	-	Ω	DC500V, 40 ~ 60% R.H.	
Floating Capacitance	C _{IO}	-	0.3	1	pF	V=0, f=1MHz	

ELECTRICAL OPTICAL CHARACTERISTICS								
PARAMETER	SYMBOL	MIN	TYP	MAX	UNIT	TEST CONDITION	NOTE	
SWITCHING CHARACTERISTICS(at Ta=0 to 70°C, V _{CC} =5V, unless specified otherwise)								
Propagation Delay Time to Logic Low	6N139	TPHL	-	5	25	μs	I _F = 0.5mA, R _L =4.7kΩ, T _A =25°C	Fig.13
			-	-	30		I _F = 0.5mA, R _L =4.7kΩ	
			-	0.2	1		I _F = 12mA, R _L =270Ω, T _A =25°C	
			-	-	2		I _F = 12mA, R _L =270Ω	
	6N138		-	1.4	10		I _F = 1.6mA, R _L =2.2kΩ, T _A =25°C	
			-	-	15		I _F = 1.6mA, R _L =2.2kΩ	
Propagation Delay Time to Logic High	6N139	TPLH	-	22	60	μs	I _F = 0.5mA, R _L =4.7kΩ, T _A =25°C	Fig.13
			-	-	90		I _F = 0.5mA, R _L =4.7kΩ	
			-	2.1	7		I _F = 12mA, R _L =270Ω, T _A =25°C	
			-	-	10		I _F = 12mA, R _L =270Ω	
	6N138		-	10.7	35		I _F = 1.6mA, R _L =2.2kΩ, T _A =25°C	
			-	-	50		I _F = 1.6mA, R _L =2.2kΩ	
Common Mode Transient Immunity at Logic High	6N139	CM _H	1000	-	-	V/μs	I _F = 0mA, V _{CM} =10Vpp, R _L =2.2kΩ, T _A =25°C	Fig.15
	6N138		1000	-	-			
Common Mode Transient Immunity at Logic Low	6N139	CM _L	1000	-	-	V/μs	I _F = 1.6mA, V _{CM} =10Vpp, R _L =2.2kΩ, T _A =25°C	Fig.15
	6N138		1000	-	-			

CHARACTERISTIC CURVES

Fig.1 Forward Current vs. Forward Voltage

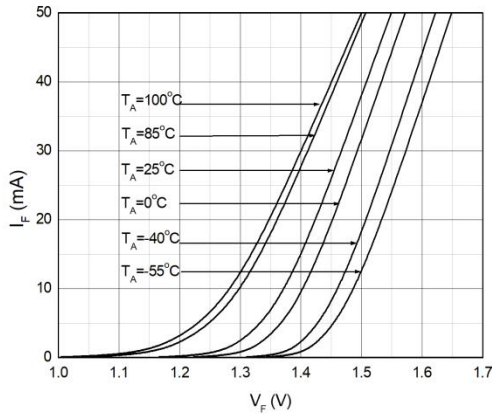

Fig.2 Current Transfer Ratio vs. Forward Current

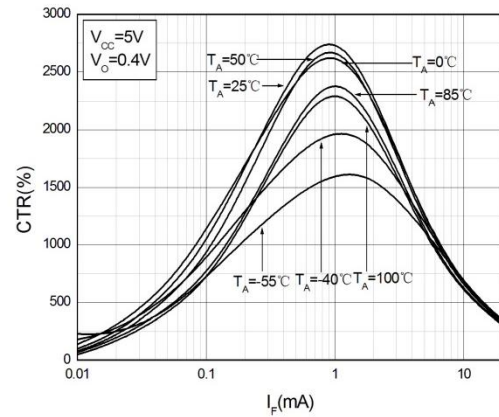

Fig.3 Normalized Current Transfer Ratio vs. Ambient Temperature

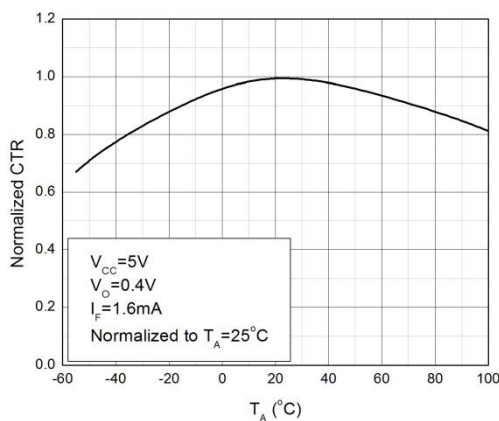

Fig.4 Current Transfer Ratio vs. Base-Emitter Resistance

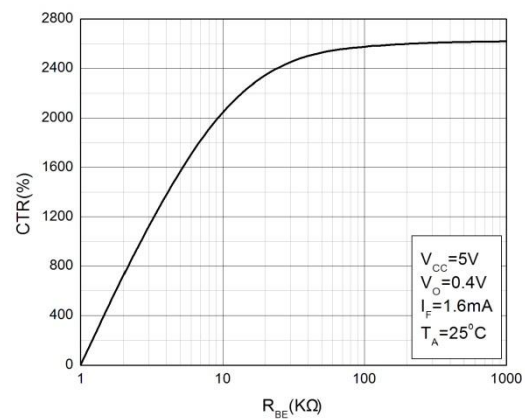

Fig.5 Low Level Output Current vs. Output Voltage

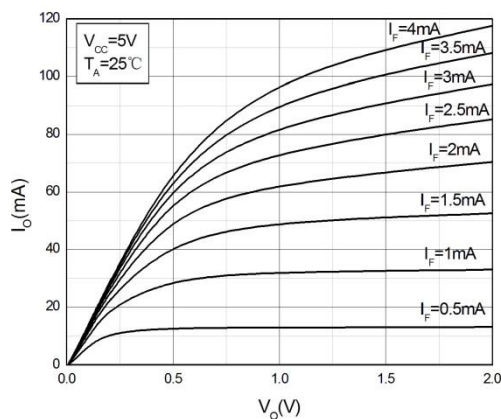
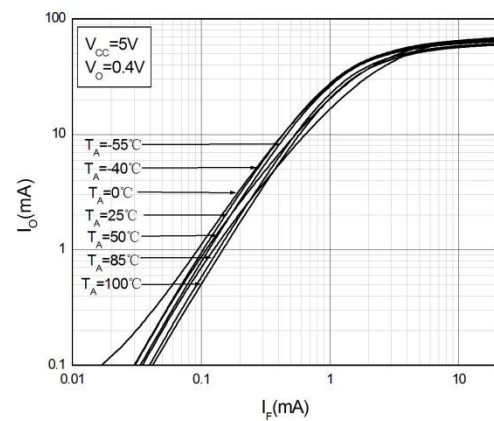

Fig.6 Low Level Output Current vs. Forward Current



CHARACTERISTIC CURVES

Fig.7 High Level Output Current vs. Ambient Temperature

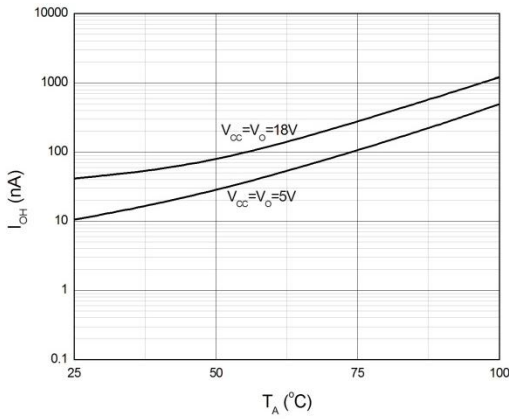

Fig.8 Propagation Delay vs. Pulse Width

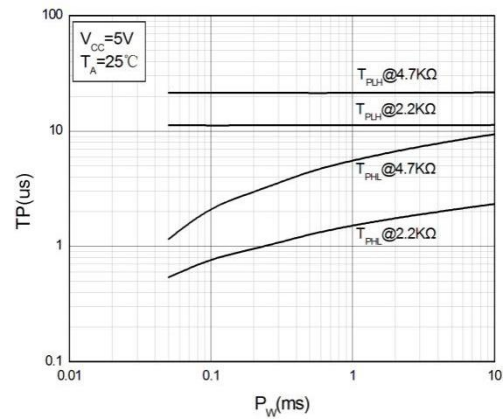

Fig.9 Rise and Fall Time vs. Load Resistance

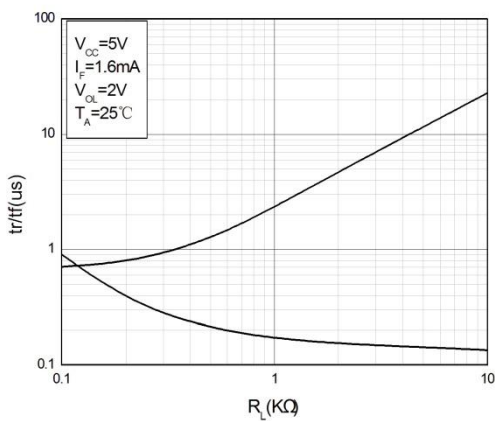

Fig.10 Propagation Delay vs. Ambient Temperature

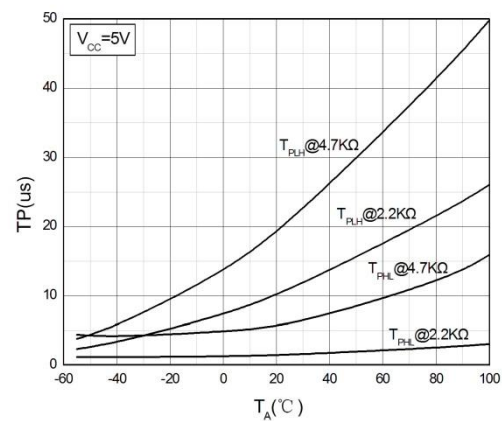

Fig.11 Propagation Delay vs. Forward Current

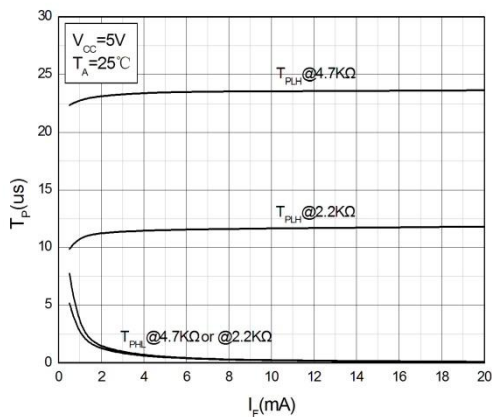
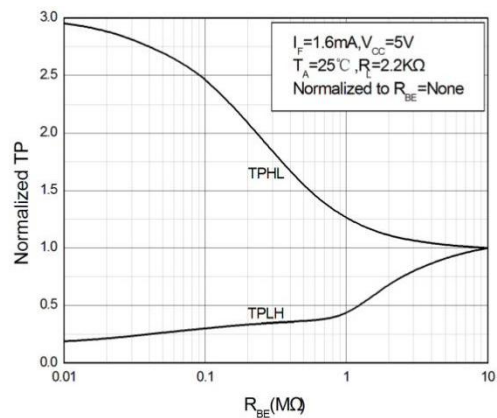

Fig.12 Propagation Delay vs. Base-Emitter Resistance



TEST CIRCUITS

Fig.13 Test Circuits for TPHL, TPLH, tr, tf

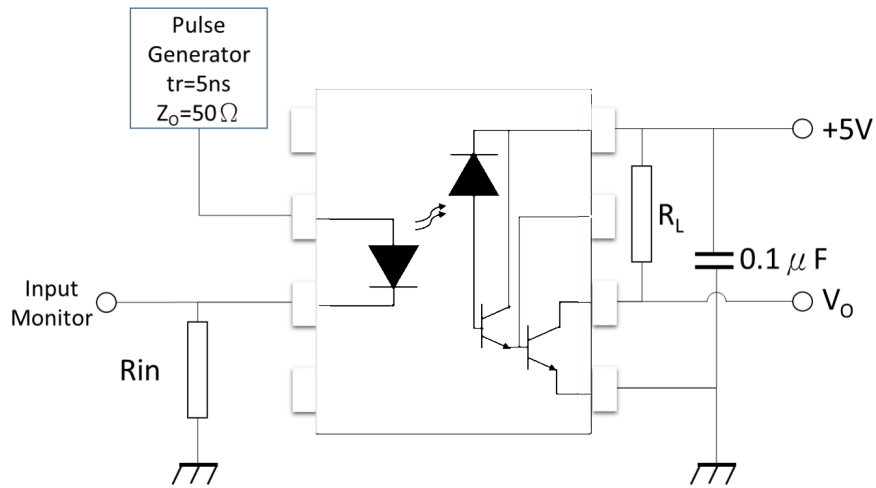
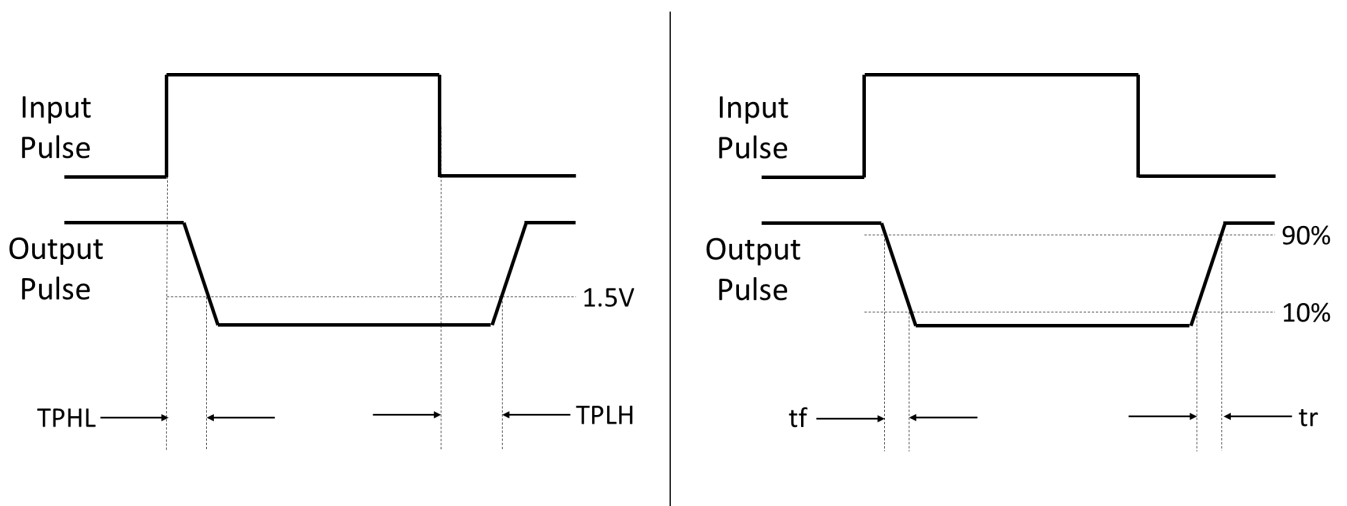

Fig.14 Waveforms of TPHL, TPLH, tr, tf



TEST CIRCUITS

Fig.15 Test Circuits for Common Mode Transient Immunity

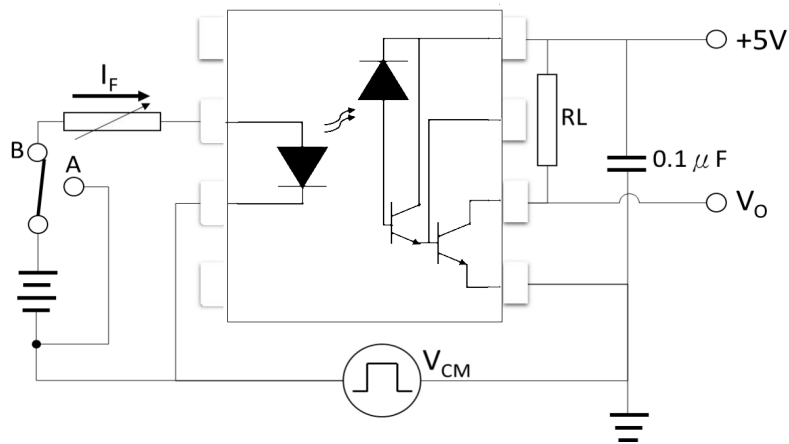
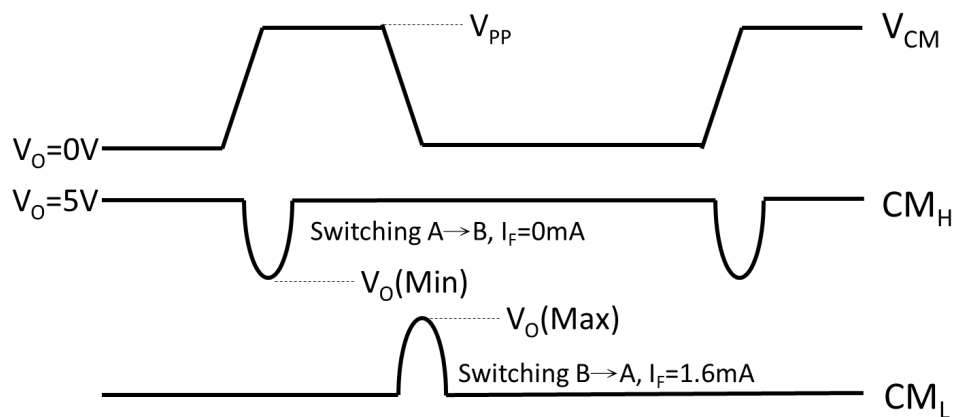
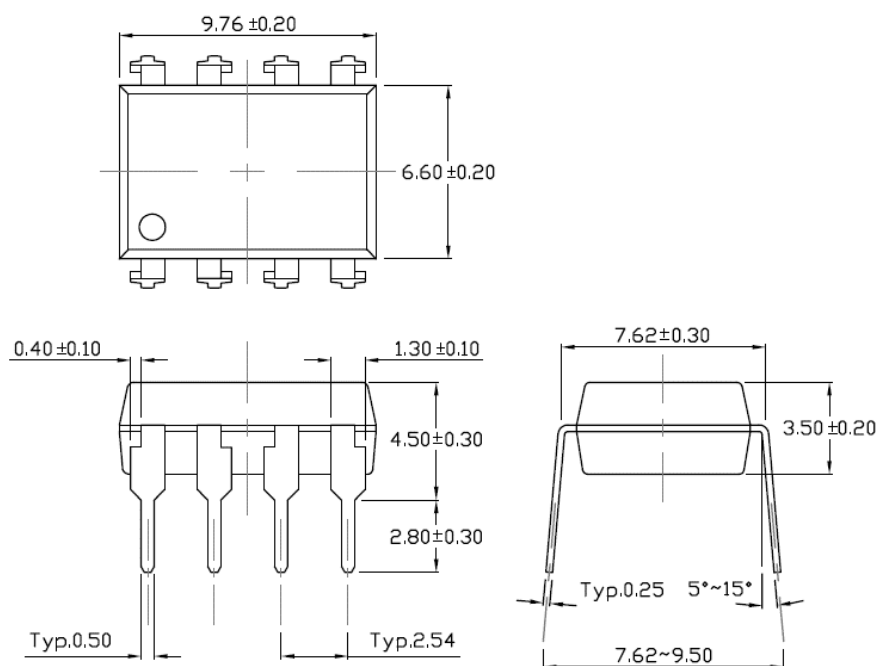

Fig.16 Waveforms of Common Mode Transient Immunity



Package Dimensions *Dimensions in mm unless otherwise stated*

DIP-8



SOP-8

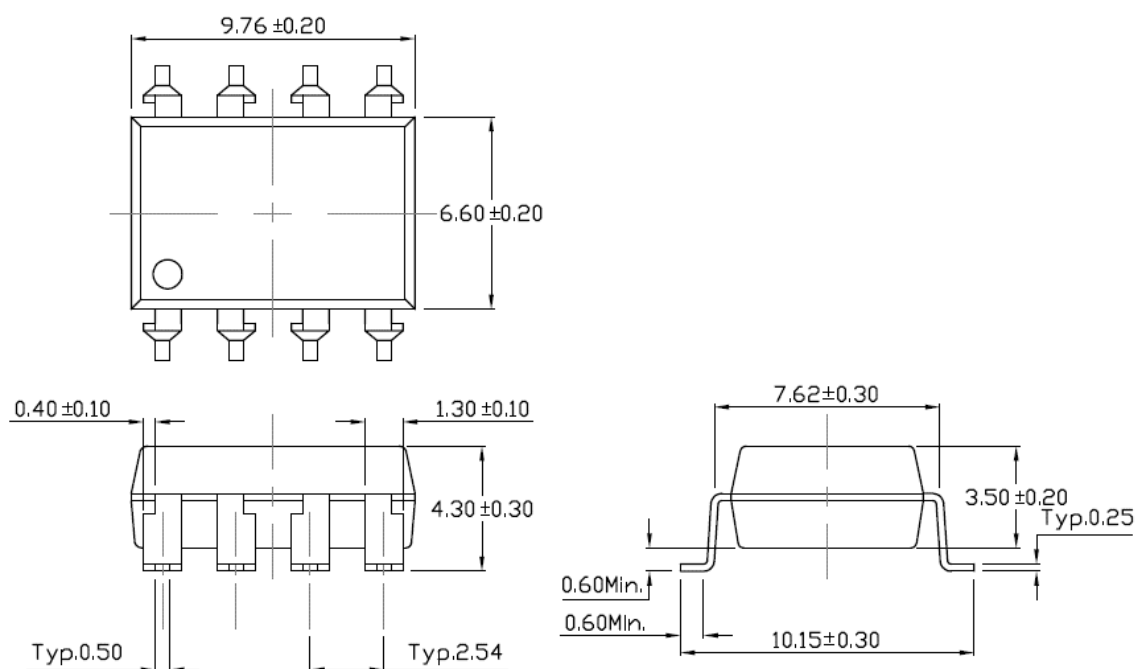

Marking

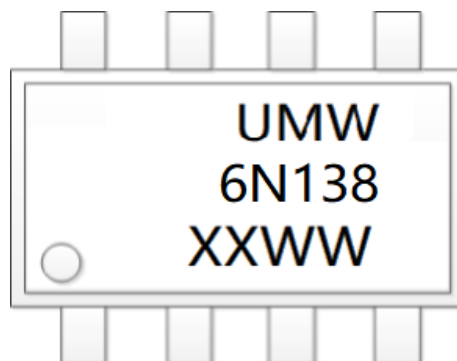

- “XX” denotes YEAR;
- “WW” denotes WEEK

ORDERING INFORMATION

Order Code	Description	Base qty
UMW 6N138M	Iron frame, DIP-8, Halogen/lead -free	1280/BOX
UMW 6N138S	Copper frame,SOP-8,Halogen-free	1000/REEL
UMW 6N139M	Iron frame, DIP-8, Halogen/lead -free	1280/BOX
UMW 6N139S	Copper frame,SOP-8,Halogen-free	1000/REEL

单击下面可查看定价，库存，交付和生命周期等信息

[>>UMW\(友台半导体\)](#)