

Summary

3524 is a pulse width modulation circuit for switching power supply. Its interior includes a reference voltage source, error amplifier, oscillator, pulse width modulation, pulse width control trigger, dual alternative output, current limiting circuit and turn off circuit.

The circuit can be used for switching power supply control of any polarity, transformer coupled DC-DC switching power supply, transformer boosting and polarity conversion, and other power supply applications.

The operating temperature of 3524 is from 0 ° C to+70 ° C.

Main features

- With 5V reference voltage source.
- The oscillation frequency range is 100Hz~300KHz.
- Good external synchronization function.
- It contains two 50mA outputs.
- With current limiting circuit.
- Complete PWM control circuit.
- Single ended or push-pull output.
- The total power current consumption is less than 10mA.

Pin diagram

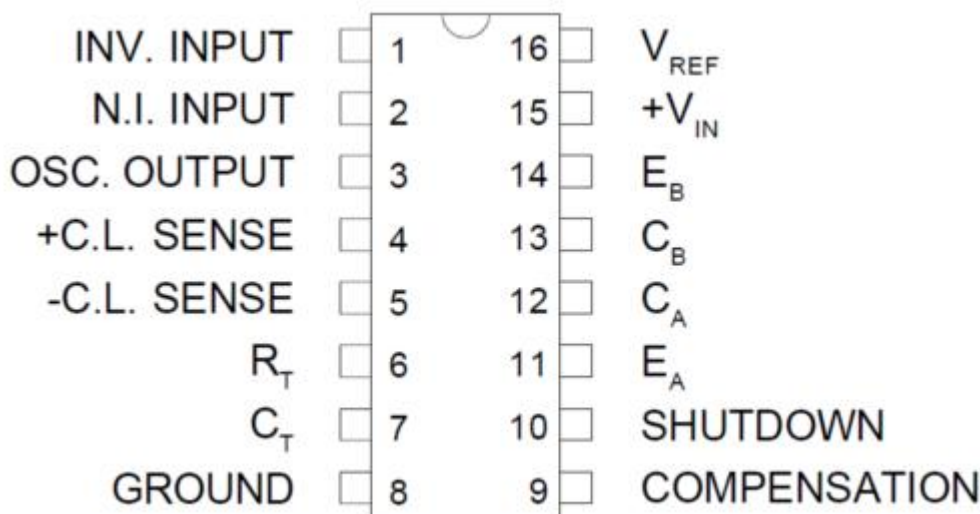

Outline drawing

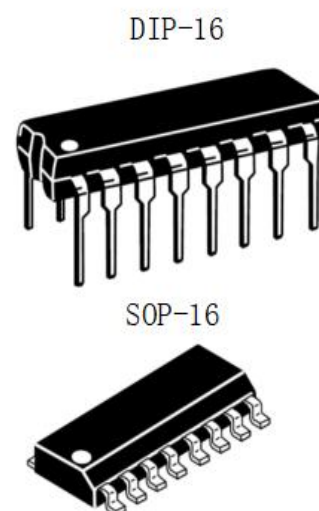

Functional block diagram

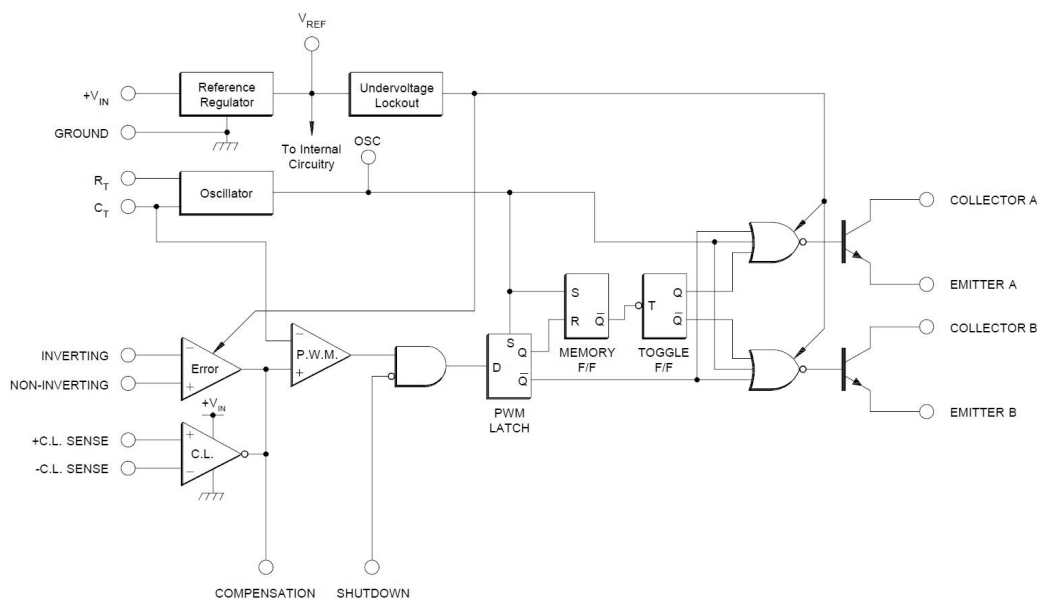

Limit parameter (Tamb=25°C unless otherwise specified)

parameter	value	unit
input voltage	42	V
collector voltage	40	V
Logic input voltage	-0.3~5.5	V
Current limiting pin differential input	-0.3~0.3	V
Output current per channel	100	mA
Reference voltage load	40	mA
Charging current at oscillating end	5	mA
Working junction temperature	150	°C

Recommended working conditions (Tamb=25°C unless otherwise specified)

parameter	value	unit
input voltage	8~40	V
collector voltage	0~40	V
Error amplifier common-mode input voltage	1.8~3.4	V
Current limiting pin differential input	-0.3~0.3	V
Output current per channel	0~50	mA
Reference voltage load	0.03~2	mA

oscillation frequency	0.1~300	KHz
Oscillating resistance	1.8~100	KΩ
Oscillating capacitance	1~1000	nF
Working junction temperature	150	°C
Operating ambient temperature	0~70	°C

Electrical characteristics

Conditions: (Tamb=25°C, Vin=20V unless otherwise specified.)

parameter	identification	test condition	Min	typical	Max	unit
Reference voltage part Vref (if not specified, IL = 0mA)						
Output voltage	Vref		4.8	5.0	5.2	V
Voltage linearity	LineReg	Vin=8V~40V			30	mV
Load linearity	LoadReg	IL = 0 to 20mA			50	mV
Reference short circuit current	Short current	VREF= 0V	25		150	mA
Oscillator (FOSC = 40KHz ,RT = 2.9KW, CT =0.01uF when not specified).						
oscillation frequency	Fosc		36		44	KHz
Frequency and voltage drift		VIN = 8V to 40V			1	%
Maximum oscillation frequency	MaxFosc	RT= 2K, CT= 1nF	200	400		KHz
Peak value of oscillation waveform			3		3.9	V
Valley value of oscillation waveform			0.6		1.2	V
Oscillating pulse width	PulseWidth		0.3		1.5	us
Error amplifier part EA (Vcm=2.5V when not specified)						
Input offset voltage	Vio				10	mV
Input bias current	Ib				10	uA
Input offset current	Iio				2	uA
DC open-loop gain	Av		60			dB
Output low level	Vol	VPIN1 - VPIN2 > 150mV		0.2	0.5	V

Input threshold voltage	Vsense		180		220	mV
Input bias current	Ib				200	uA
Shutdown of circuit shutdown						
Turn off threshold voltage	Vth		0.5	0.8	1.2	V
Output part (each output)						
Collector leakage current	Cleak	VCE = 40V			50	uA
Collector voltage drop	Vcsat	IC = 50mA			2	V
Emitter output voltage	Ve	IE = 50mA	17			V
Collector output rise time	Risetime	RC = 2K			0.4	us
Collector output falling time	Falltime	RC = 2K			0.2	us
Circuit as a whole						
Static working current	Icc	VIN = 40V			10	mA

characteristic curve

Relation between oscillation frequency and Rt, Ct

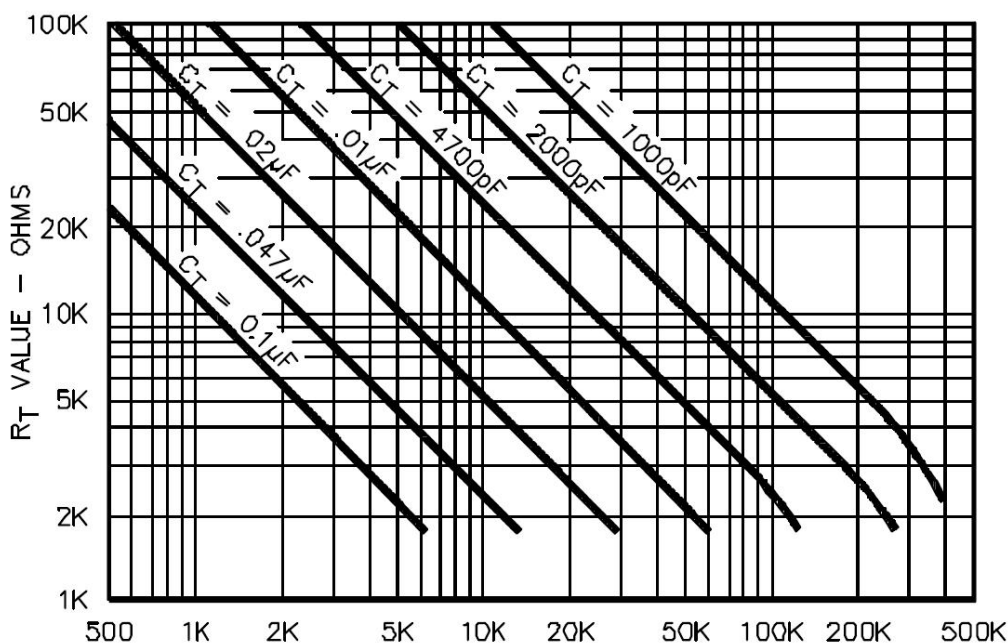

Relation between dead time and C_T

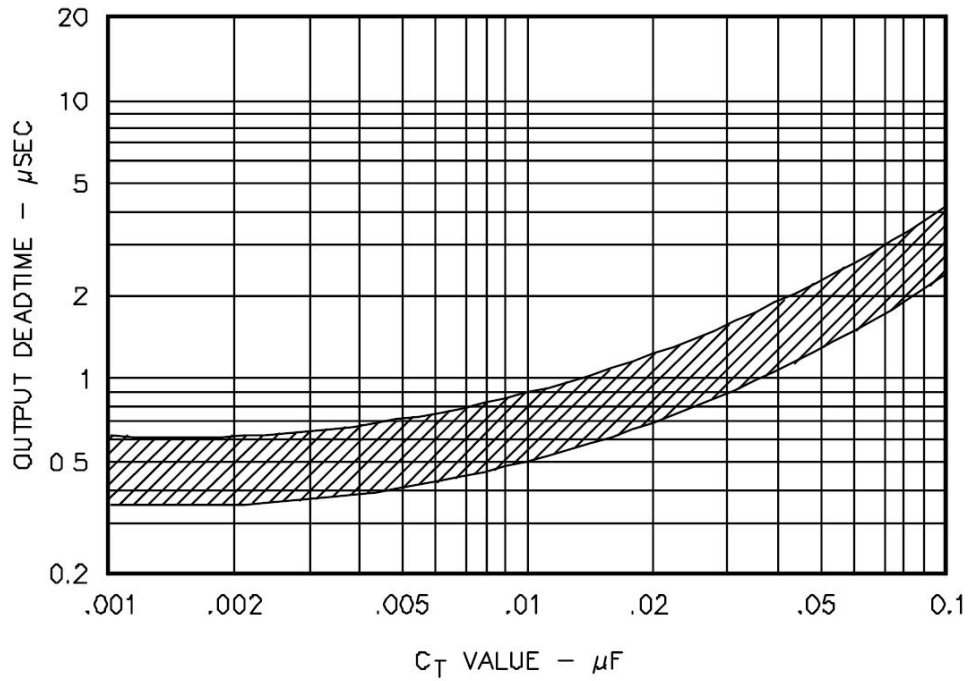

Typical applications

1. Internal current limiting circuit diagram

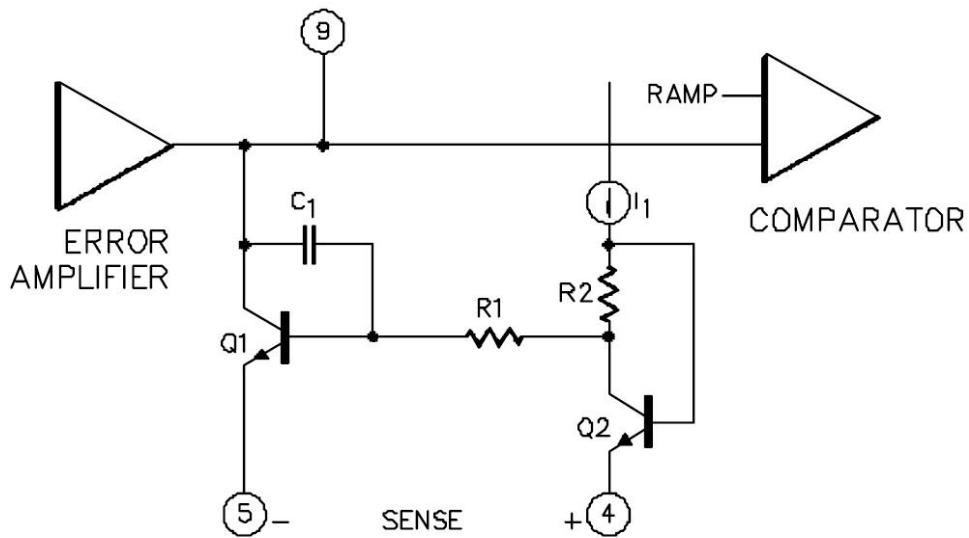

2. Single end output application (terminal output control can reach 0~90% duty cycle)

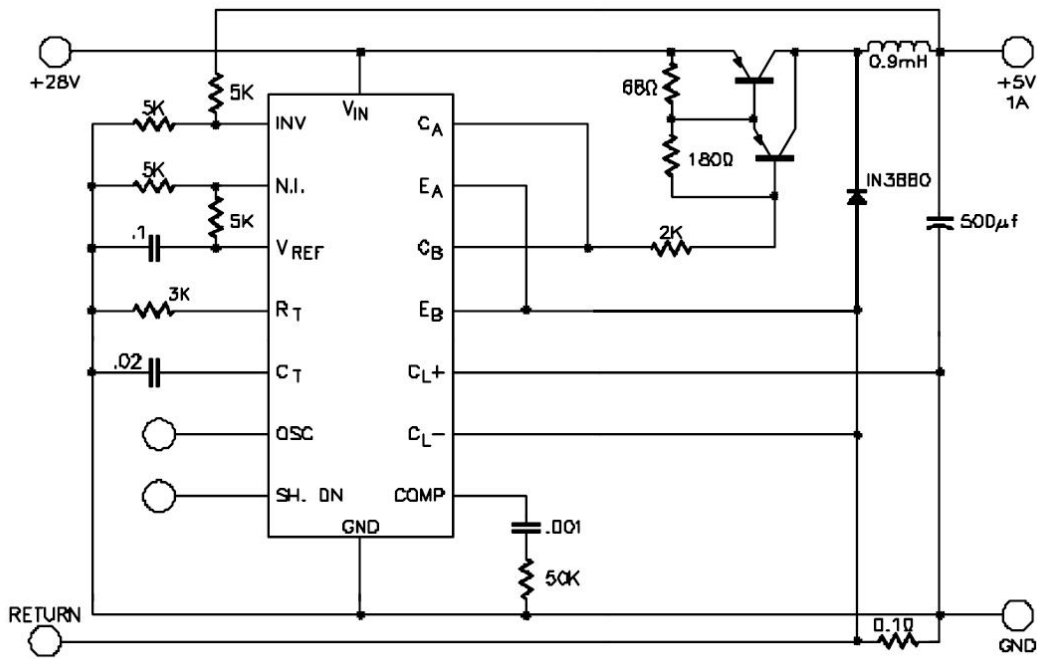

3. Push pull output application

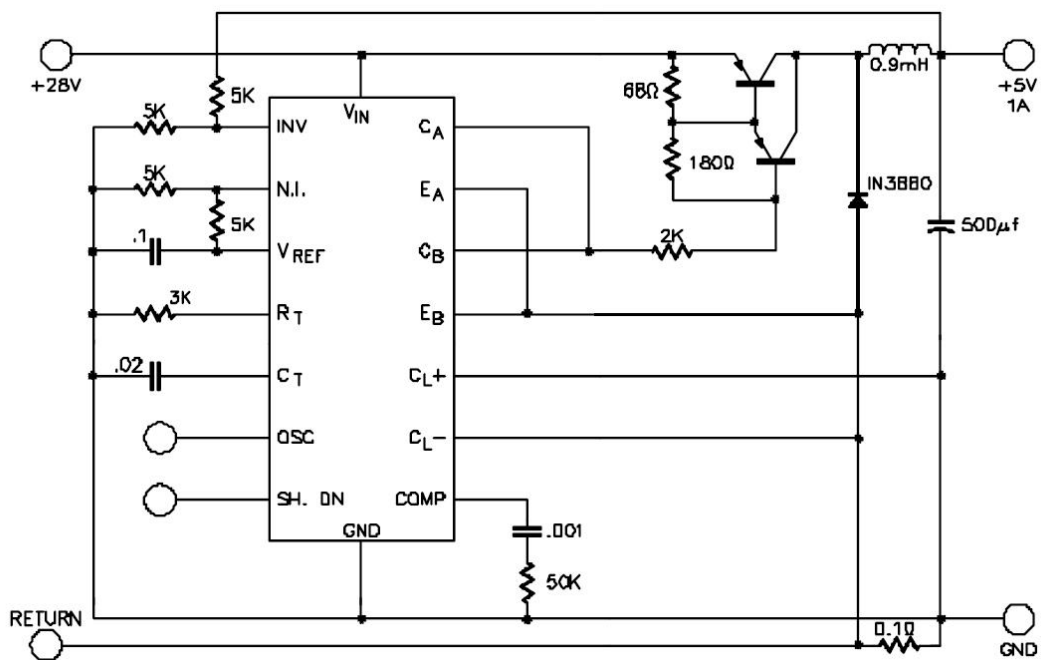

Encapsulation mechanical data:

SOP16

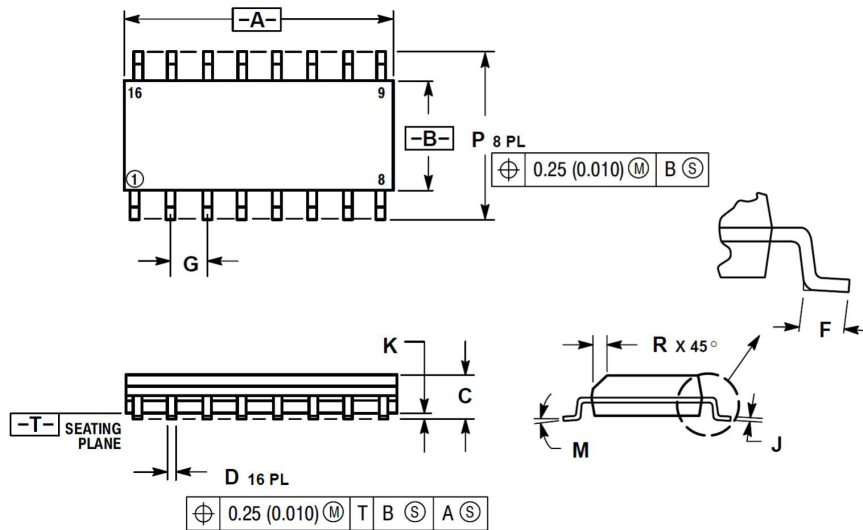

DIM	MILLIMETERS		INCHES	
	MIN	MAX	MIN	MAX
A	9.80	10.00	0.386	0.393
B	3.80	4.00	0.150	0.157
C	1.35	1.75	0.054	0.068
D	0.35	0.49	0.014	0.019
F	0.40	1.25	0.016	0.049
G	1.27 BSC		0.050 BSC	
J	0.19	0.25	0.008	0.009
K	0.10	0.25	0.004	0.009
M	0°	7°	0°	7°
P	5.80	6.20	0.229	0.244
R	0.25	0.50	0.010	0.019

DIP16

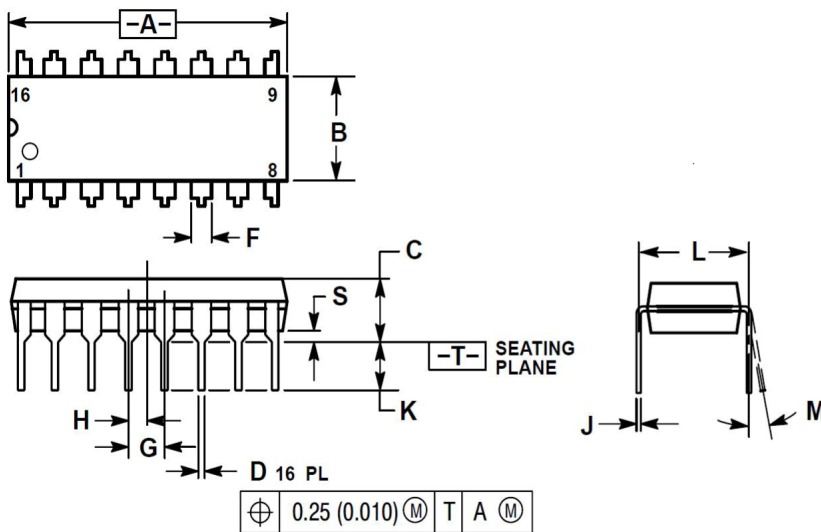

DIM	INCHES		MILLIMETERS	
	MIN	MAX	MIN	MAX
A	0.740	0.770	18.80	19.55
B	0.250	0.270	6.35	6.85
C	0.145	0.175	3.69	4.44
D	0.015	0.021	0.39	0.53
F	0.040	0.70	1.02	1.77
G	0.100 BSC		2.54 BSC	
H	0.050 BSC		1.27 BSC	
J	0.008	0.015	0.21	0.38
K	0.110	0.130	2.80	3.30
L	0.295	0.305	7.50	7.74
M	0°	10°	0°	10°
S	0.020	0.040	0.51	1.01

Marking

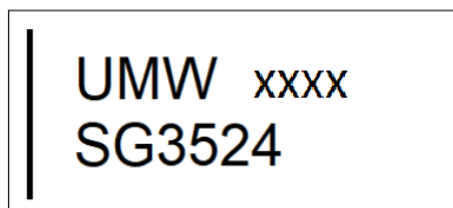

Ordering information

Order code	Package	Baseqty	Deliverymode
UMW SG3524DR	SOP-16	2500	Tape and reel
UMW SG3524N	DIP-16	2500	Tape and reel

单击下面可查看定价，库存，交付和生命周期等信息

[>>UMW\(友台半导体\)](#)