

### ●最大额定值 (TC=25°C)

#### ● Absolute Maximum Ratings (Tc=25°C)

TO-220/220F/262/263

参数 PARAMETER	符号 SYMBOL	额定值 VALUE	单位 UNIT
漏-源电压 Drain-source Voltage	$V_{DS}$	650	V
栅-源电压 gate-source Voltage	$V_{GS}$	$\pm 20$	V
漏极电流 Continuous Drain Current TC=25°C	$I_D$	10	A
漏极电流 Continuous Drain Current TC=100°C	$I_D$	6	A
最大脉冲电流 Drain Current — Pulsed ①	$I_{DM}$	40	A
耗散功率 Power Dissipation	$P_{tot}$	TO-220	W
		TO-220F	
		TO-262/263	
最高结温 Junction Temperature	$T_j$	150	°C
存储温度 Storage Temperature	$T_{STG}$	-55-150	°C
单脉冲雪崩能量 Single Pulse Avalanche Energy②	$E_{AS}$	500	mJ

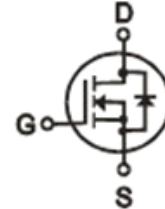

$V_{DS}=650V$

$R_{DS(ON)}=0.9\Omega$

$I_D=10A$

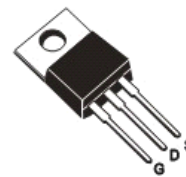

TO-220

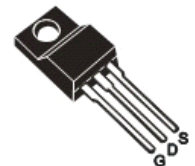

TO-220F

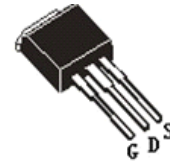

TO-262 (I<sup>2</sup>PAK)

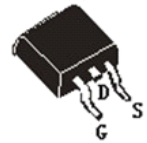

TO-263 (D<sup>2</sup>PAK)

### ●电特性 (Tc=25°C)

#### ● Electronic Characteristics (Tc=25°C)

参数 PARAMETER	符号 SYMBOL	测试条件 TEST CONDITION	最小值 MIN	典型值 TYP	最大值 MAX	单位 UNIT
漏-源击穿电压 Drain-source Breakdown Voltage	$BV_{DSS}$	$V_{GS}=0V, I_D=250\mu A$	650			V
击穿电压温度系数 Breakdown Voltage Temperature Coefficient	$\Delta BV_{DSS}/\Delta T_j$	$I_D=250\mu A$ , Referenced to 25°C		0.65		V/°C
栅极开启电压 Gate Threshold Voltage	$V_{GS(TH)}$	$V_{GS}=V_{DS}, I_D=250\mu A$	2.0		4.0	V
漏-源漏电流 Drain-source Leakage Current	$I_{DSS}$	$V_{DS}=650V,$ $V_{GS}=0V, T_j=25^\circ C$			1	$\mu A$
		$V_{DS}=480V,$ $V_{GS}=0V, T_j=125^\circ C$			10	$\mu A$
跨导 Forward Transconductance	$g_{fs}$	$V_{DS}=40V, I_D=5.0A$ ③		8		S

参数 PARAMETER	符号 SYMBOL	测试条件 TEST CONDITION	最小值 MIN	典型值 TYP	最大值 MAX	单位 UNIT
栅极漏电流 Gate-body Leakage Current ( $V_{DS} = 0$ )	$I_{GSS}$	$V_{GS} = \pm 20V$			$\pm 100$	nA
漏-源导通电阻 Static Drain-source On Resistance	$R_{DS(ON)}$	$V_{GS} = 10V, I_D = 5.0A$ ③		0.75	0.9	$\Omega$
输入电容 Input Capacitance	$C_{iss}$	$V_{GS} = 0V, V_{DS} = 25V$ $F = 1.0MHz$		1570		pF
关断延迟 Turn -Off Delay Time	$T_d(off)$	$V_{DD} = 300V, I_D = 10A$ $R_G = 25\Omega$ ③		130		ns
栅极电荷 Total Gate Charge	$Q_g$	$I_D = 10A, V_{DS} = 480V$ $V_{GS} = 10V$ ③		45		nC
栅源电荷 Gate-to-Source Charge	$Q_{gs}$			7.5		nC
栅漏电荷 Gate-to-Drain Charge	$Q_{gd}$			18.5		nC
二极管正向电流 Continuous Diode Forward Current	$I_S$				10	A
二极管正向压降 Diode Forward Voltage	$V_{SD}$	$T_j = 25^\circ C, I_S = 10A$ $V_{GS} = 0V$ ③			1.4	V
反向恢复时间 Reverse Recovery Time	$t_{rr}$	$T_j = 25^\circ C, I_f = 10A$ $di/dt = 100A/\mu s$ ③		420		ns
反向恢复电荷 Reverse Recovery Charge	$Q_{rr}$			4.2		$\mu C$

### ●热特性

#### ● Thermal Characteristics

参数 PARAMETER	符号 SYMBOL	最大值 MAX			单位 UNIT
		TO-220	TO-220F	TO-262/263	
热阻结-壳 Thermal Resistance Junction-case	$R_{thJC}$	0.80	2.50	1.0	$^\circ C/W$
热阻结-环境 Thermal Resistance Junction-ambient	$R_{thJA}$	62.5	62.5	62.5	$^\circ C/W$

### 注释(Notes):

- ① 脉冲宽度：以最高节温为限制  
Repetitive rating: Pulse width limited by maximum junction temperature
- ② 初始结温= $25^\circ C$ ,  $V_{DD} = 50V$ ,  $L = 10mH$ ,  $R_G = 25\Omega$ ,  $I_{AS} = 10A$   
Starting  $T_j = 25^\circ C$ ,  $V_{DD} = 50V$ ,  $L = 10mH$ ,  $R_G = 25\Omega$ ,  $I_{AS} = 10A$
- ③ 脉冲测试：脉冲宽度 $\leq 300\mu s$ ，占空比 $\leq 2\%$   
Pulse Test : Pulse width  $\leq 300\mu s$ , Duty cycle  $\leq 2\%$

● 特性曲线



图 1 输出特性曲线, Tc=25°C

Fig1 Typical Output Characteristics, Tc=25°C

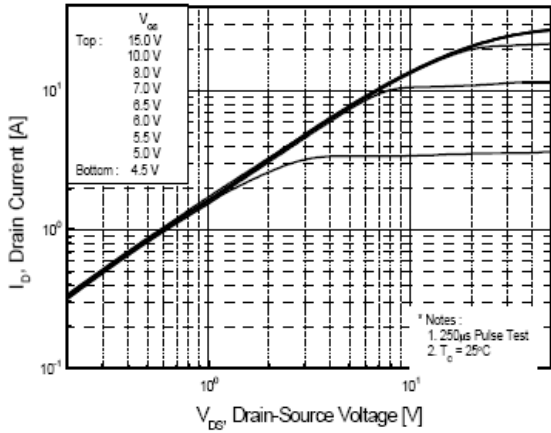

图 2 导通电阻与漏极电流和栅极电压曲线

Fig2 On-Resistance Vs.Drain Current and Gate Voltage

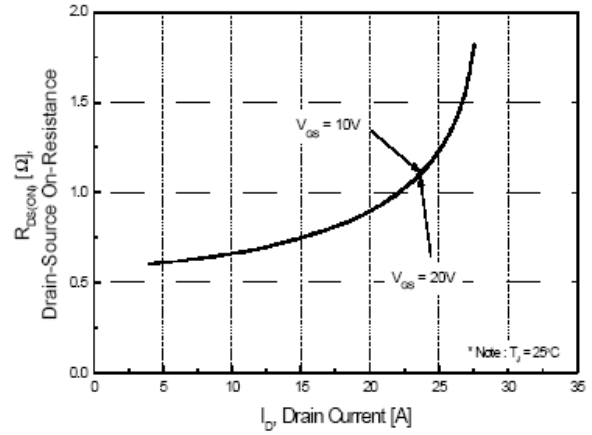

图 3 导通电阻与温度曲线

Fig3 Normalized On-Resistance Vs.Temperature

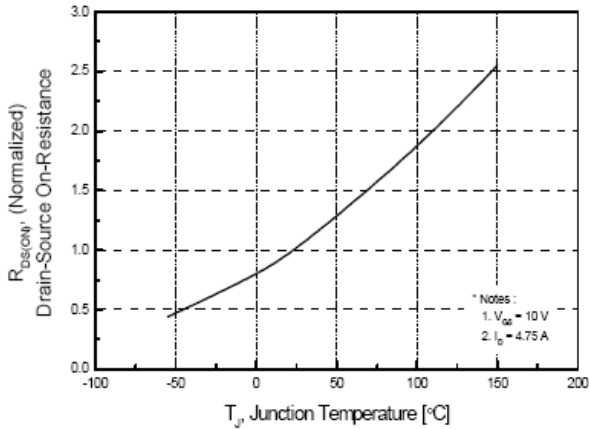

图 4 二极管正向电压曲线

Fig4 Typical Source-Drain Diode Forward Voltage

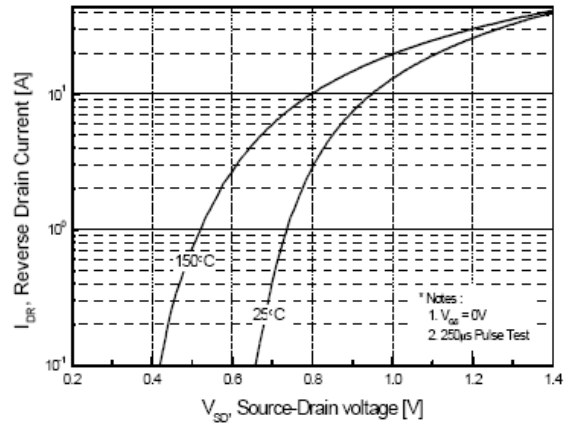

图 5 最大漏极电流与壳温曲线

Fig5 Maximum Drain Current Vs.Case Temperature

● 特性曲线

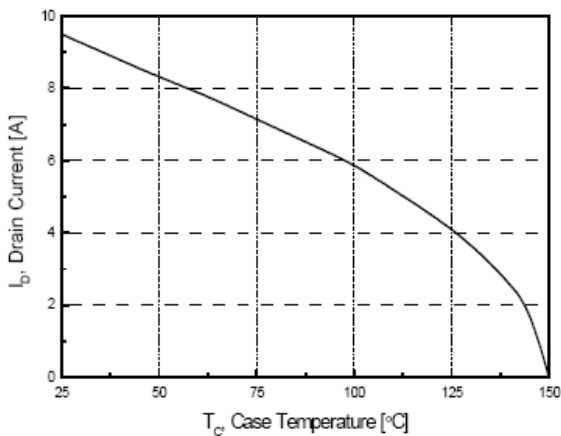

图 6-1 10N65(TO-220)

最大安全工作区曲线

Fig6-1 Maximum Safe Operating Area

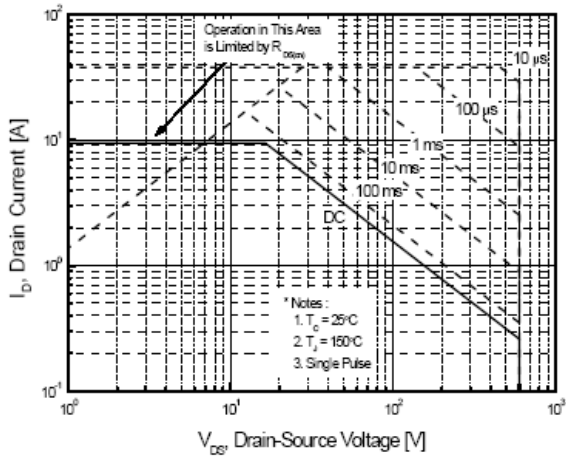

图 6-1 10N65(TO-220F)

最大安全工作区曲线

Fig6 -2Maximum Safe Operating Area

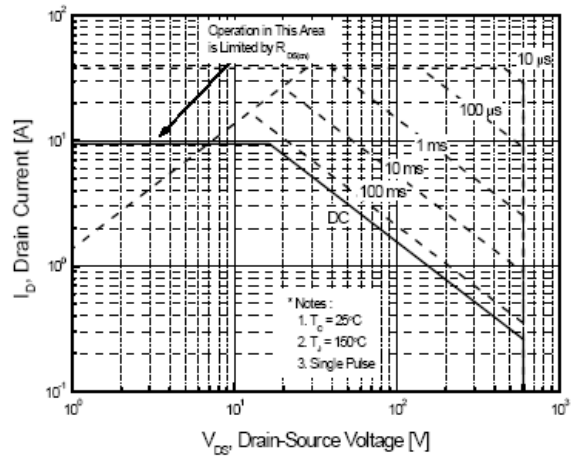

图 6-3 10N65(TO-262&263)

最大安全工作区曲线

Fig6-3 Maximum Safe Operating Area

TO-220 封装

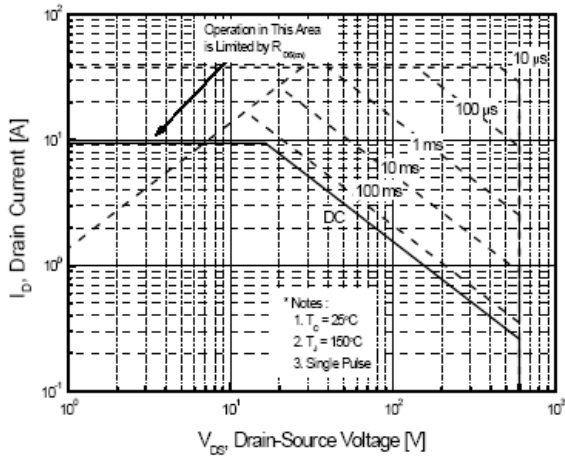
单位：毫米/UNIT: mm

符号 SYMBOL	最小值 min	典型值 nom	最大值 max	符号 SYMBOL	最小值 min	典型值 nom	最大值 max
A	4.00		4.80	E	9.90		10.70
B	1.20		1.50	e		2.54	
B1	1.00		1.40	F	1.10		1.45
b1	0.65		1.00	L	12.50		14.50
c	0.35		0.75	L1	3.00	3.50	4.00
D	15.00		16.50	Q	2.50		3.00
D1	5.90		6.90	Q1	2.00		3.00
				φP	3.60		3.90

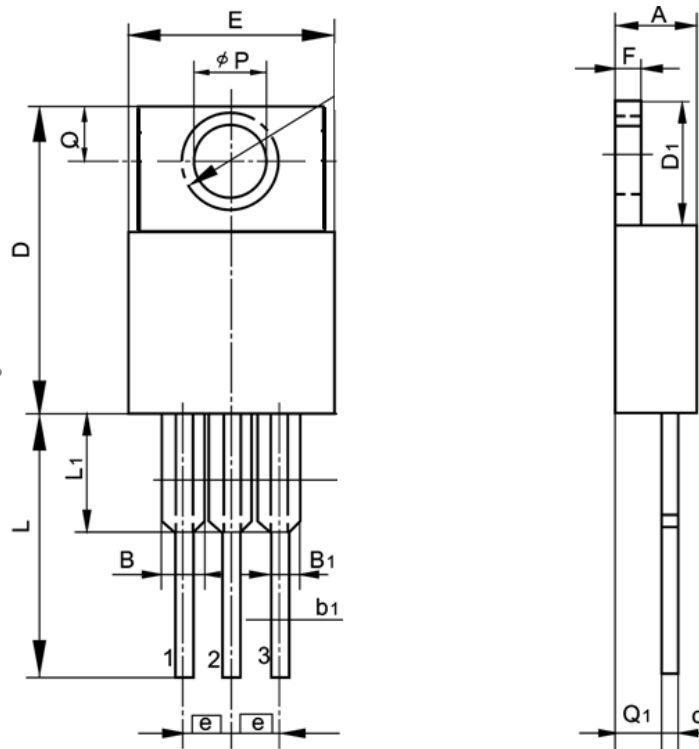

TO-220F 封装

单位:毫米/UNIT: mm

符号 SYMBOL	最小值 min	典型值 nom	最大值 max	符号 SYMBOL	最小值 min	典型值 nom	最大值 max
A	4.40		4.95	e		2.54	
A <sub>1</sub>	2.30		2.90	L	12.50		14.30
b	0.45		0.90	L <sub>1</sub>	9.10		10.05
b <sub>1</sub>	1.10		1.70	L <sub>2</sub>	15.00		16.00
c	0.35		0.90	L <sub>3</sub>	3.00		4.00
D	14.50		17.00	øp	3.00		3.50
D1	6.10		9.00	Q	2.30		2.80
E	9.60		10.30				

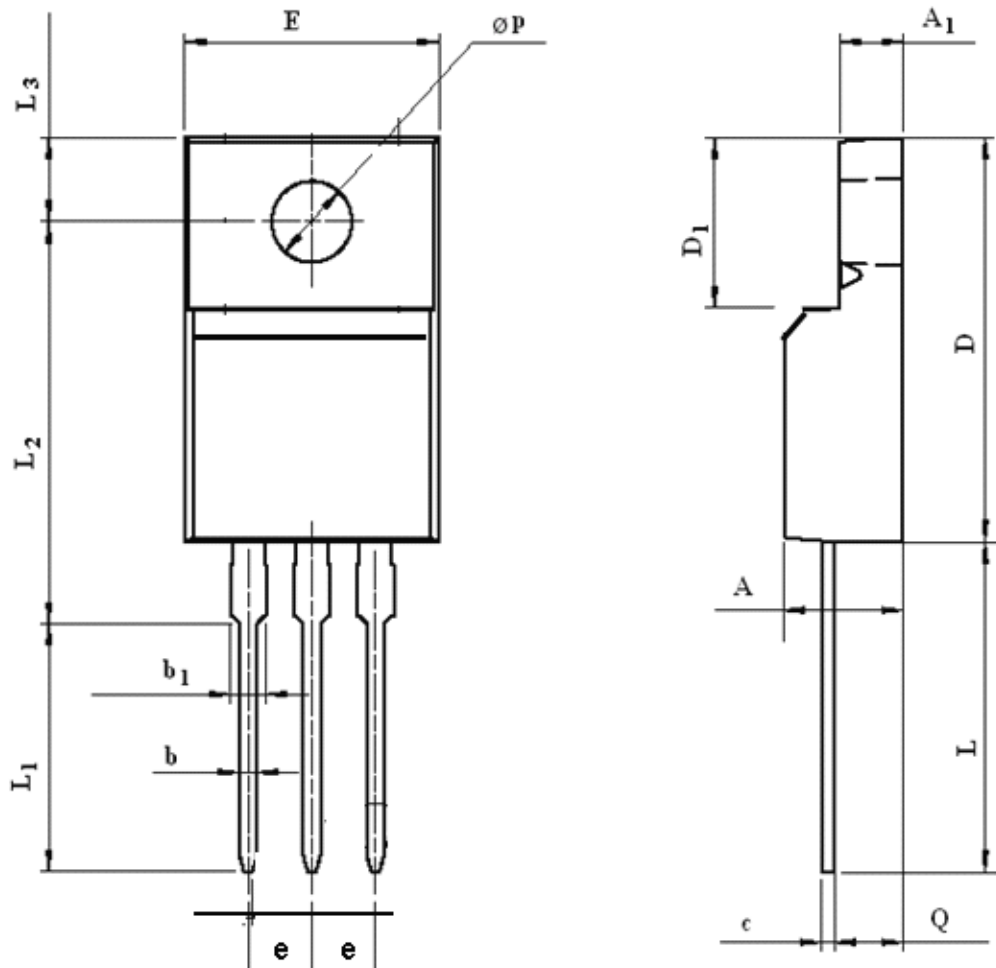

TO-262 封装

单位：毫米/UNIT: mm

符号 SYMBOL	最小值 min	典型值 nom	最大值 max	符号 SYMBOL	最小值 min	典型值 nom	最大值 max
A	3.80		4.80	e		2.54	
A1	2.00		2.80	e1			5.30
b	0.60		1.00	E	9.90		10.70
b1	1.20		1.40	L	12.50		14.50
c	0.40		0.70	L1	0.80	1.00	1.20
c2	1.10		1.40	L2			1.50
D			9.60				

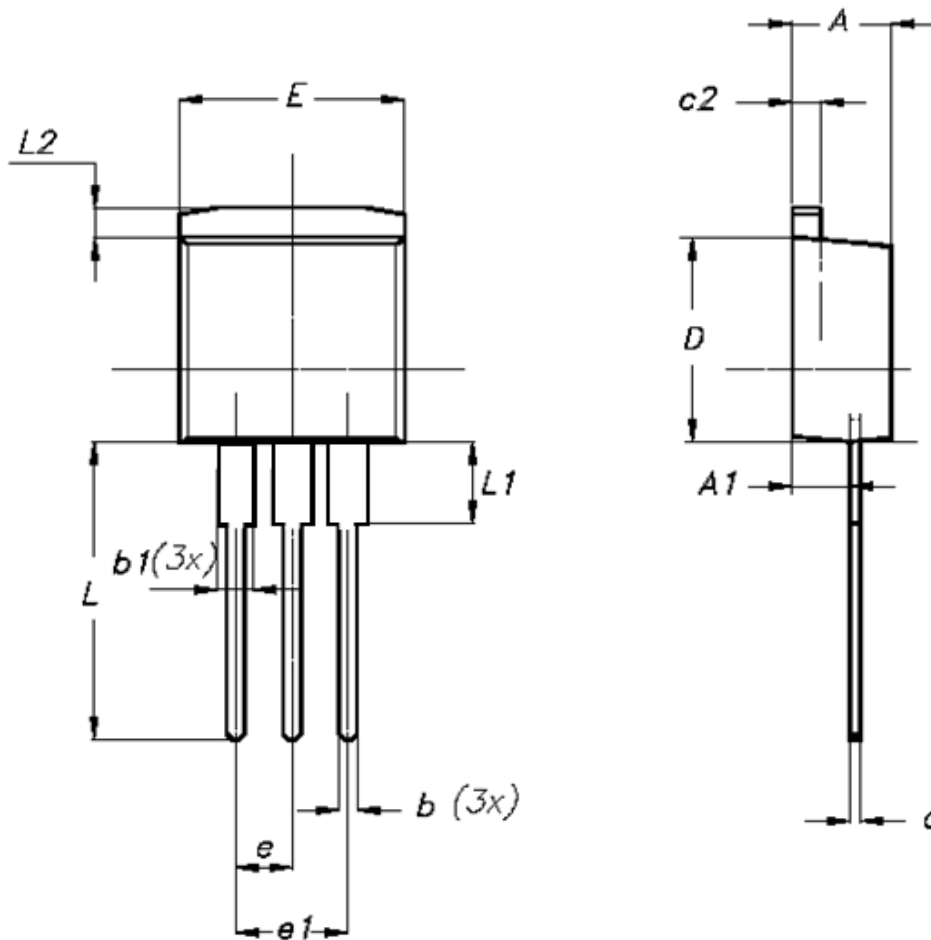

TO-263 封装

单位：毫米/UNIT: mm

符号 SYMBOL	最小值 min	典型值 nom	最大值 max	符号 SYMBOL	最小值 min	典型值 nom	最大值 max
A	4.42		4.72	E	8.99		9.29
B	1.22		1.32	e1	2.44		2.64
b	0.76		0.86	e2	4.98		5.18
b1	1.22		1.32	L1	15.19		15.79
b2	0.33		0.43	L2	2.29		2.79
C	1.22		1.32	L3	1.30		1.75
D	9.95		10.25				

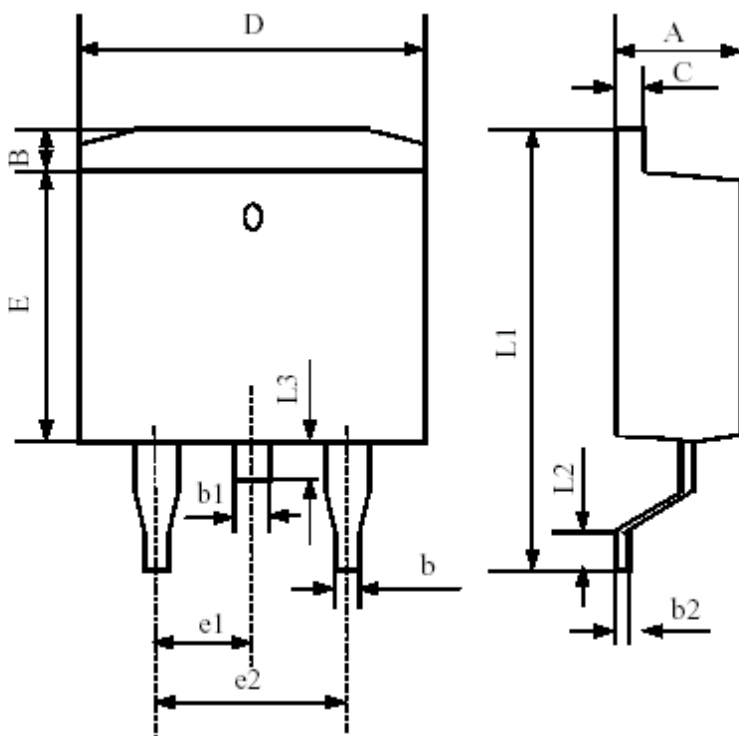



TO-263 编带规格

单位:毫米/UNIT: mm

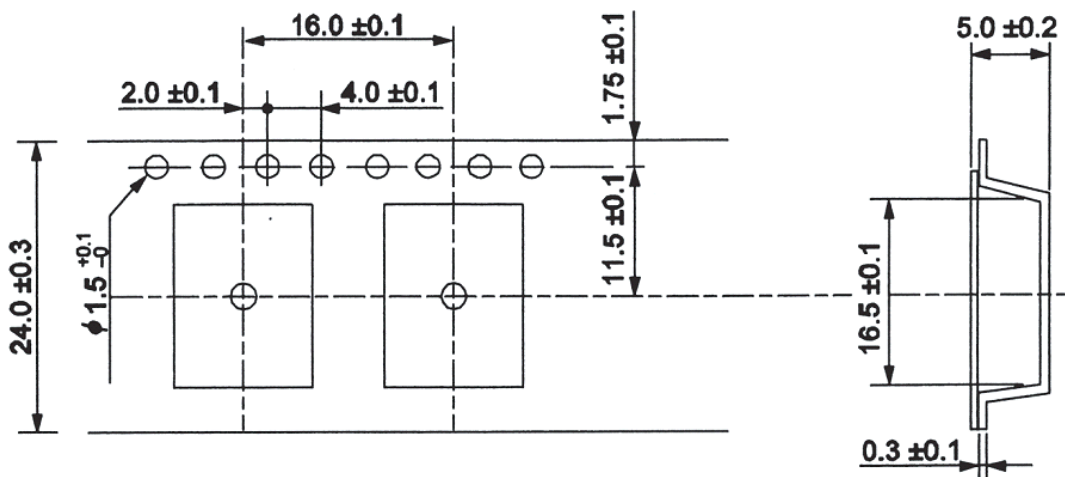

使用供带方向/USER DIRECTION OF FEED

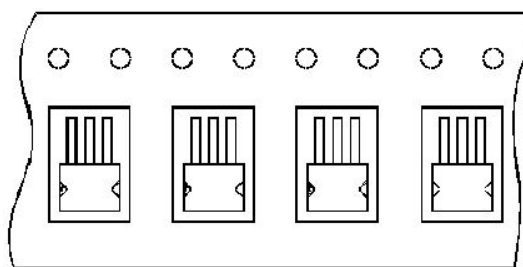

编带器件定位示意图/UNIT ORIENTATION

单击下面可查看定价，库存，交付和生命周期等信息

[>>UMW\(友台半导体\)](#)