

Low Capacitance 2-Line ESD Protection

Features

- Ultra low leakage: nA level
- Operating voltage: 5V
- Low clamping voltage
- Complies with following standards:
  - IEC 61000-4-2 (ESD) immunity test
    - Air discharge: ±30kV
    - Contact discharge: ±30kV
  - IEC61000-4-4 (EFT) 40A (5/50ns)
  - IEC61000-4-5 (Lightning) 6A (8/20µs)
- RoHS Compliant

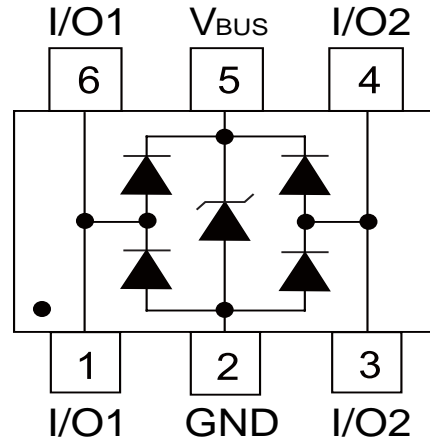

Applications

- USB 2.0 interface
- 10/100 Ethernet
- Personal digital assistants (PDA's)
- Notebooks, Desktops and Servers
- Portable instrumentation
- Digital cameras

Mechanical Characteristics

- Package: SOT23-6 Lead
- Finish: Matte Tin
- UL Flammability Classification Rating 94V-0
- Pb-Free, Halogen Free, RoHS/WEEE Compliant

Absolute Maximum Ratings (T<sub>A</sub>=25°C unless otherwise specified)

Parameter	Symbol	Value	Unit
Peak Pulse Power (8/20µs)	P <sub>pk</sub>	150	W
Peak Pulse Current (8/20µs)	I <sub>pp</sub>	6	A
ESD per IEC 61000-4-2 (Air)	V <sub>ESD</sub>	±30	kV
ESD per IEC 61000-4-2 (Contact)		±30	
Operating Temperature Range	T <sub>J</sub>	-55 to +125	°C
Storage Temperature Range	T <sub>stg</sub>	-55 to +150	°C

## Low Capacitance 2-Line ESD Protection

### Electrical Characteristics ( $T_A=25^{\circ}\text{C}$ unless otherwise specified)

Parameter	Symbol	Test Condition	Min	Typ	Max	Unit
Reverse stand-off voltage	$V_{RWM}$				5	V
Reverse breakdown voltage	$V_{BR}$	$I_{BR}=1\text{mA}$	6		9	V
Reverse leakage current	$I_R$	$V_R=5\text{V}$			0.1	$\mu\text{A}$
Clamping voltage ( $t_p=8/20\mu\text{s}$ )	$V_C$	$I_{PP}=1\text{A}$			10	V
Clamping voltage ( $t_p=8/20\mu\text{s}$ )	$V_C$	$I_{PP}=6\text{A}$			15	V
Junction capacitance	$C_J$	0Vdc, f=1MHz Between I/O pins and GND		0.8	1	pF
	$C_J$	0Vdc, f=1MHz I/O to I/O		0.35	0.4	pF

Low Capacitance 2-Line ESD Protection

Typical Characteristics

Fig1. 8/20μs Pulse Waveform

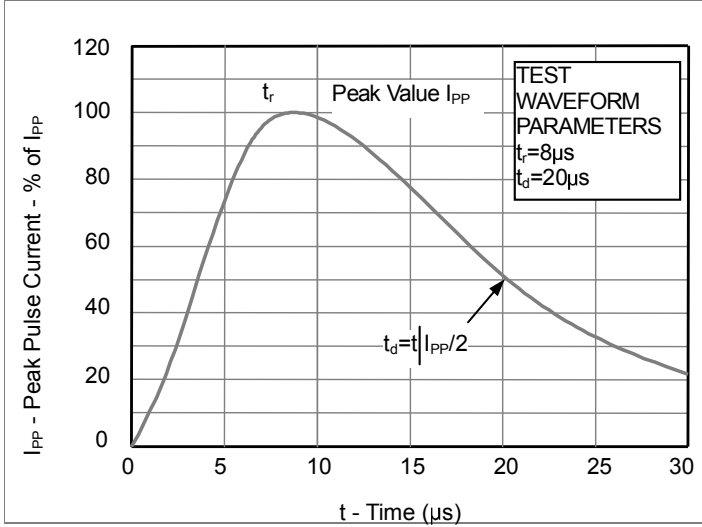

Fig2. ESD Pulse Waveform (according to IEC 61000-4-2)

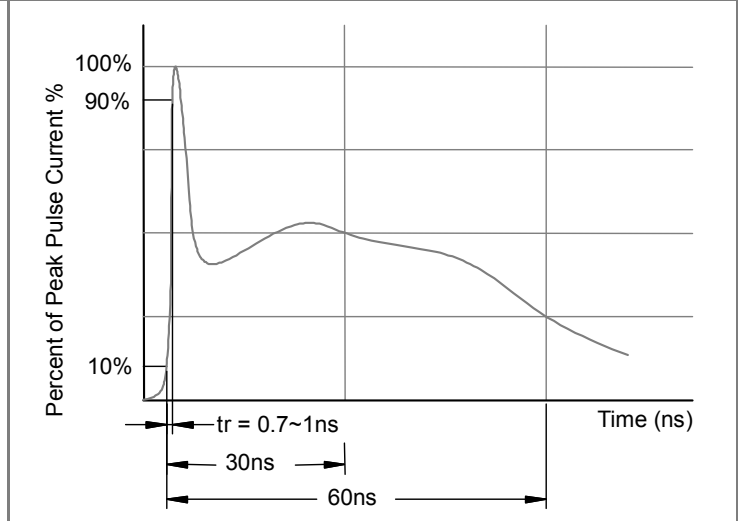
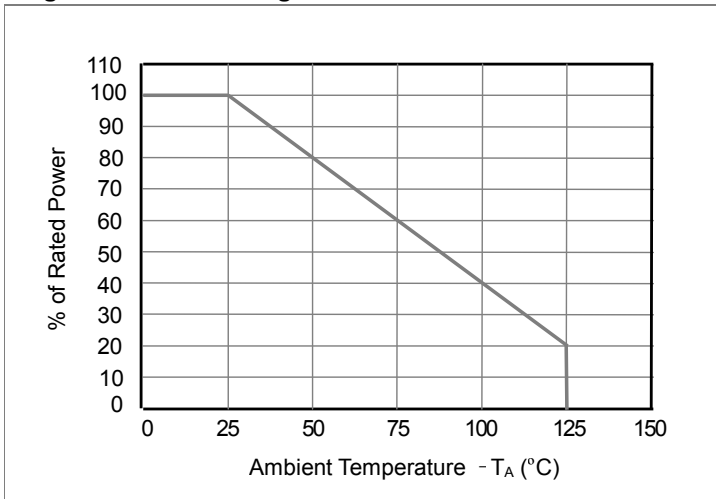
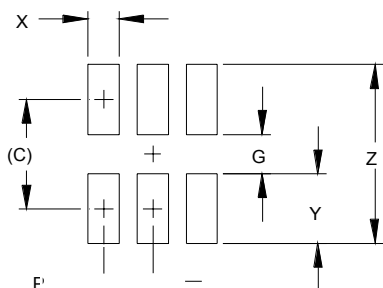

Fig3. Power Derating Curve



Outline Drawing – SOD323



DIMENSIONS		
DIM	INCHES	MILLIMETERS
C	(.098)	(2.50)
G	.055	1.40
P	.037	0.95
X	.024	0.60
Y	.043	1.10
Z	.141	3.60

Marking

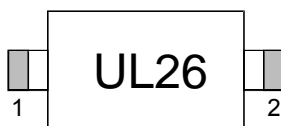

Ordering information

Order code	Package	Base qty	Delivery mode
UMW USBLC6-2SC6	SOD323	3000	Tape and reel

单击下面可查看定价，库存，交付和生命周期等信息

[>>UMW\(友台半导体\)](#)