

SOT-23 Plastic-Encapsulate MOSFETS

UMW SI2302B N-Channel 20-V(D-S) MOSFET

$V_{(BR)DSS}$	$R_{DS(on)MAX}$	I_D
20V	80mΩ@4.5V	2.5A
	100mΩ@2.5V	

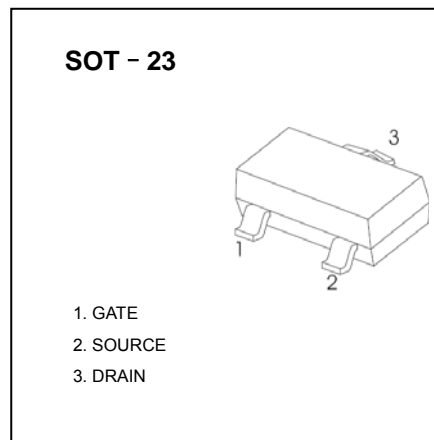

FEATURE

- TrenchFET Power MOSFET

APPLICATION

- Load Switch for Portable Devices
- DC/DC Converter

MARKING

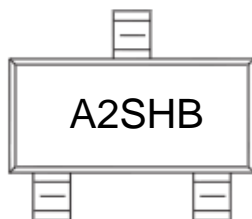

Equivalent Circuit

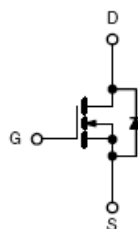

Maximum ratings ($T_a=25^{\circ}C$ unless otherwise noted)

Parameter	Symbol	Value	Unit
Drain-Source Voltage	V_{DS}	20	V
Gate-Source Voltage	V_{GS}	±8	
Continuous Drain Current	I_D	2.5	A
Continuous Source-Drain Current(Diode Conduction)	I_S	0.6	
Power Dissipation	P_D	0.4	W
Thermal Resistance from Junction to Ambient ($t \leq 5s$)	$R_{\theta JA}$	312.5	$^{\circ}C/W$
Operating Junction	T_J	150	$^{\circ}C$
Storage Temperature	T_{STG}	-55 ~ +150	

T_a=25 °C unless otherwise specified

Parameter	Symbol	Test Condition	Min	Typ	Max	Units
Static						
Drain-source breakdown voltage	V _{(BR)DSS}	V _{GS} = 0V, I _D = 10μA	20			V
Gate-threshold voltage	V _{GS(th)}	V _{DS} = V _{GS} , I _D = 50μA	0.65	0.95	1.2	
Gate-body leakage	I _{GSS}	V _{DS} = 0V, V _{GS} = ±8V			±100	nA
Zero gate voltage drain current	I _{DSS}	V _{DS} = 20V, V _{GS} = 0V			1	μA
Drain-source on-resistance ^a	r _{DS(on)}	V _{GS} = 4.5V, I _D = 2.6A		0.045	0.070	Ω
		V _{GS} = 2.5V, I _D = 2.1A		0.060	0.100	
Forward transconductance ^a	g _{fs}	V _{DS} = 5V, I _D = 3.6A		8		S
Diode forward voltage	V _{SD}	I _S = 0.94A, V _{GS} = 0V		0.76	1.2	V
Dynamic						
Total gate charge	Q _g	V _{DS} = 10V, V _{GS} = 4.5V, I _D = 3.6A		4.0	10	nC
Gate-source charge	Q _{gs}			0.65		
Gate-drain charge	Q _{gd}			1.5		
Input capacitance ^b	C _{iss}	V _{DS} = 10V, V _{GS} = 0V, f = 1MHz		300		pF
Output capacitance ^b	C _{oss}			120		
Reverse transfer capacitance ^b	C _{rss}			80		
Switching^b						
Turn-on delay time	t _{d(on)}	V _{DD} = 10V, R _L = 5.5Ω, I _D ≈ 3.6A, V _{GEN} = 4.5V, R _g = 6Ω		7	15	ns
Rise time	t _r			55	80	
Turn-off delay time	t _{d(off)}			16	60	
Fall time	t _f			10	25	

Notes :

- Pulse Test : Pulse width ≤ 300μs, duty cycle ≤ 2%.
- These parameters have no way to verify.

SOT-23 PACKAGE OUTLINE DIMENSIONS

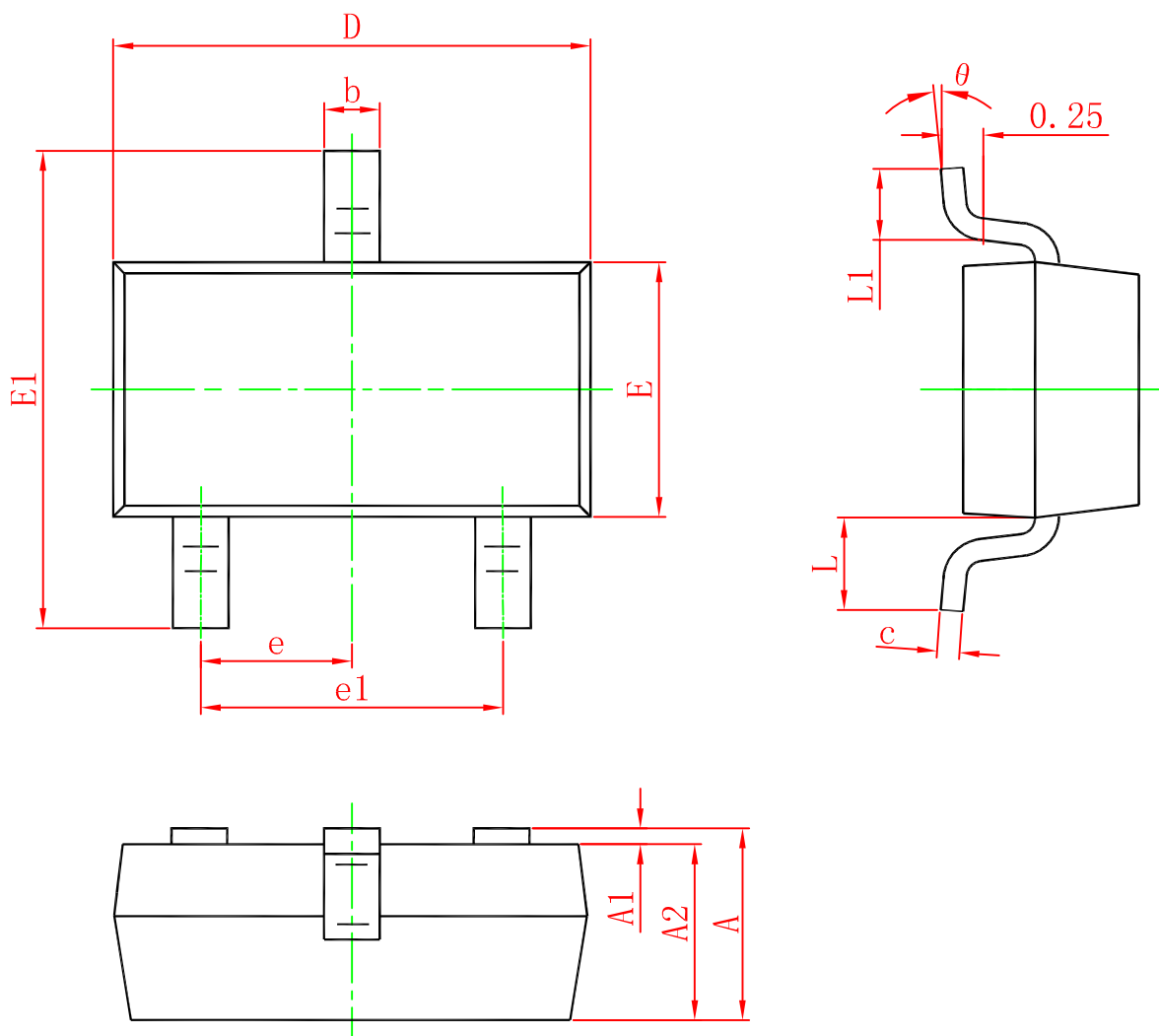

Symbol	Dimensions In Millimeters		Dimensions In Inches	
	Min.	Max.	Min.	Max.
A	0.900	1.150	0.035	0.045
A1	0.000	0.100	0.000	0.004
A2	0.900	1.050	0.035	0.041
b	0.300	0.500	0.012	0.020
c	0.080	0.150	0.003	0.006
D	2.800	3.000	0.110	0.118
E	1.200	1.400	0.047	0.055
E1	2.250	2.550	0.089	0.100
e	0.950 TYP.		0.037 TYP.	
e1	1.800	2.000	0.071	0.079
L	0.550 REF.		0.022 REF.	
L1	0.300	0.500	0.012	0.020
θ	0°	8°	0°	8°

单击下面可查看定价，库存，交付和生命周期等信息

[>>UMW\(友台半导体\)](#)