

**FEATURES**

- $V_{DS} (V) = -30V$
- $R_{DS(ON)} < 64m\ \Omega$  ( $V_{GS} = -10V$ )
- $R_{DS(ON)} < 103m\ \Omega$  ( $V_{GS} = -4.5V$ )

**Application(s)**

- System/Load Switch

**Benefits**

- Lower switching losses
- Multi-vendor compatibility
- Easier manufacturing
- Environmentally friendly
- Increased reliability

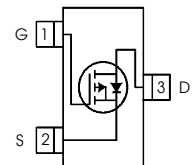
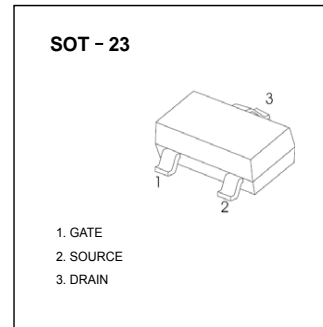

| Symbol                   | Parameter                                | Max.         | Units      |
|--------------------------|--|--------------|------------|
| $V_{DS}$                 | Drain-Source Voltage                     | -30          | V          |
| $I_D @ T_A = 25^\circ C$ | Continuous Drain Current, $V_{GS} @ 10V$ | -3.6         | A          |
| $I_D @ T_A = 70^\circ C$ | Continuous Drain Current, $V_{GS} @ 10V$ | -2.9         |            |
| $I_{DM}$                 | Pulsed Drain Current                     | -15          |            |
| $P_D @ T_A = 25^\circ C$ | Maximum Power Dissipation                | 1.3          | W          |
| $P_D @ T_A = 70^\circ C$ | Maximum Power Dissipation                | 0.8          |            |
|                          | Linear Derating Factor                   | 0.01         |            |
| $V_{GS}$                 | Gate-to-Source Voltage                   | $\pm 20$     | V          |
| $T_J, T_{STG}$           | Junction and Storage Temperature Range   | -55 to + 150 | $^\circ C$ |

**Thermal Resistance**

| Symbol          | Parameter                           | Typ. | Max. | Units        |
|-----------------|-------------------------------------|------|------|--------------|
| $R_{\theta JA}$ | Junction-to-Ambient ③               |      | 100  | $^\circ C/W$ |
| $R_{\theta JA}$ | Junction-to-Ambient ( $t < 10s$ ) ④ |      | 99   |              |

**Notes:**

- ① Repetitive rating; pulse width limited by max. junction temperature.
- ② Pulse width  $\leq 400\mu s$ ; duty cycle  $\leq 2\%$ .
- ③ Surface mounted on 1 in square Cu board

### Electric Characteristics @ $T_J = 25^\circ\text{C}$ (unless otherwise specified)

| Symbol                          | Parameter                            | Min. | Typ. | Max. | Units               | Conditions  |
|---------------------------------|--------------------------------------|------|------|------|---------------------|---|
| $V_{(BR)DSS}$                   | Drain-to-Source Breakdown Voltage    | -30  |      |      | V                   | $V_{GS} = 0V, I_D = -250\mu A$                        |
| $\Delta V_{(BR)DSS}/\Delta T_J$ | Breakdown Voltage Temp. Coefficient  |      | 0.02 |      | V/ $^\circ\text{C}$ | Reference to $25^\circ\text{C}, I_D = -1\text{mA}$    |
| $R_{DS(on)}$                    | Static Drain-to-Source On-Resistance |      | 51   | 64   | $m\Omega$           | $V_{GS} = -10V, I_D = -3.6A$ ②                        |
|                                 |                                      |      | 82   | 103  |                     | $V_{GS} = -4.5V, I_D = -2.9A$ ②                       |
| $V_{GS(th)}$                    | Gate Threshold Voltage               | -1.3 |      | -2.4 | V                   | $V_{DS} = V_{GS}, I_D = -10\mu A$                     |
| $I_{DSS}$                       | Drain-to-Source Leakage Current      |      |      | 1    | $\mu A$             | $V_{DS} = -24V, V_{GS} = 0V$                          |
|                                 |                                      |      |      | 150  |                     | $V_{DS} = -24V, V_{GS} = 0V, T_J = 125^\circ\text{C}$ |
| $I_{GSS}$                       | Gate-to-Source Forward Leakage       |      |      | -100 | nA                  | $V_{GS} = -20V$                                       |
|                                 | Gate-to-Source Reverse Leakage       |      |      | 100  |                     | $V_{GS} = 20V$  |
| $R_G$                           | Internal Gate Resistance             |      | 12   |      | $\Omega$            |   |
| $g_{fs}$                        | Forward Transconductance             | 5.0  |      |      | S                   | $V_{DS} = -10V, I_D = -3.6A$                          |
| $Q_g$                           | Total Gate Charge                    |      | 4.8  |      | nC                  | $I_D = -3.6A$   |
| $Q_{gs}$                        | Gate-to-Source Charge                |      | 1.2  |      |                     | $V_{DS} = -15V$                                       |
| $Q_{gd}$                        | Gate-to-Drain ("Miller") Charge      |      | 2.5  |      |                     | $V_{GS} = -4.5V$ ②                                    |
| $t_{d(on)}$                     | Turn-On Delay Time                   |      | 9.6  |      | ns                  | $V_{DD} = -15V$ ②                                     |
| $t_r$                           | Rise Time                            |      | 19   |      |                     | $I_D = -1A$   |
| $t_{d(off)}$                    | Turn-Off Delay Time                  |      | 16   |      |                     | $R_G = 6.8\Omega$                                     |
| $t_f$                           | Fall Time                            |      | 15   |      |                     | $V_{GS} = -4.5V$                                      |
| $C_{iss}$                       | Input Capacitance                    |      | 388  |      | pF                  | $V_{GS} = 0V$   |
| $C_{oss}$                       | Output Capacitance                   |      | 93   |      |                     | $V_{DS} = -25V$                                       |
| $C_{rss}$                       | Reverse Transfer Capacitance         |      | 65   |      |                     | $f = 1.0\text{KHz}$                                   |

### Source - Drain Ratings and Characteristics

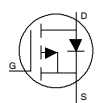
| Symbol   | Parameter                                 | Min. | Typ. | Max. | Units | Conditions   |
|----------|---|------|------|------|-------|--|
| $I_S$    | Continuous Source Current<br>(Body Diode) |      |      | -1.3 | A     | MOSFET symbol showing the integral reverse p-n junction diode.  |
| $I_{SM}$ | Pulsed Source Current<br>(Body Diode) ①   |      |      | -15  |       |  |
| $V_{SD}$ | Diode Forward Voltage                     |      |      | -1.2 | V     | $T_J = 25^\circ\text{C}, I_S = -1.3A, V_{GS} = 0V$ ②   |
| $t_{rr}$ | Reverse Recovery Time                     |      | 14   | 21   | ns    | $T_J = 25^\circ\text{C}, V_R = -24V, I_F = -1.3A$  |
| $Q_{rr}$ | Reverse Recovery Charge                   |      | 7.2  | 11   | nC    | $di/dt = 100A/\mu s$ ②   |

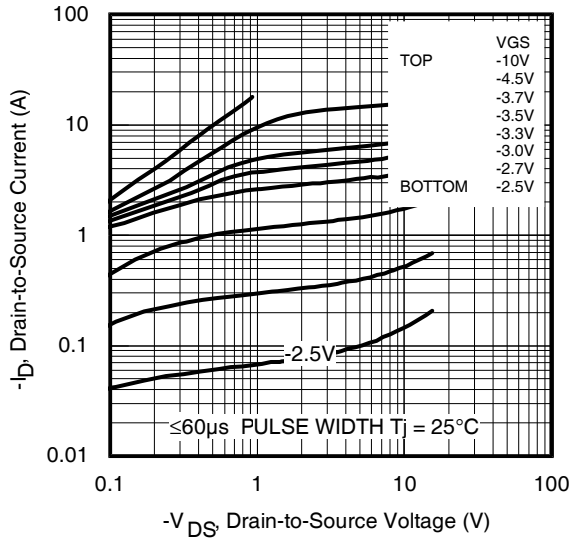

Fig 1. Typical Output Characteristics

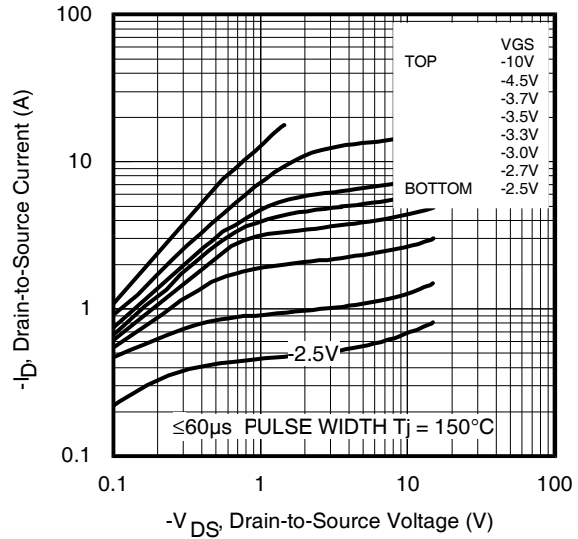

Fig 2. Typical Output Characteristics

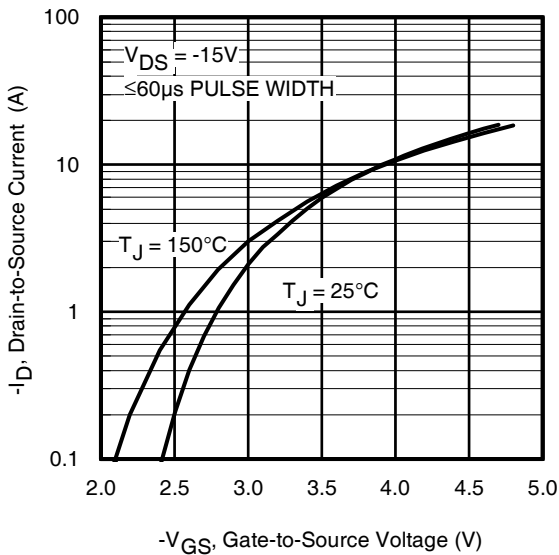

Fig 3. Typical Transfer Characteristics

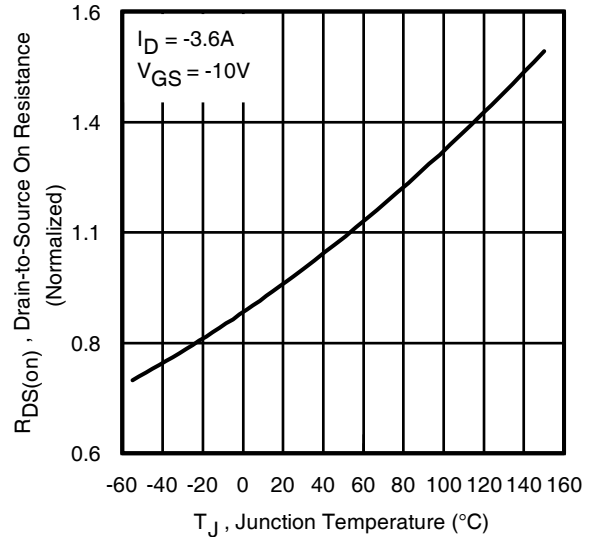
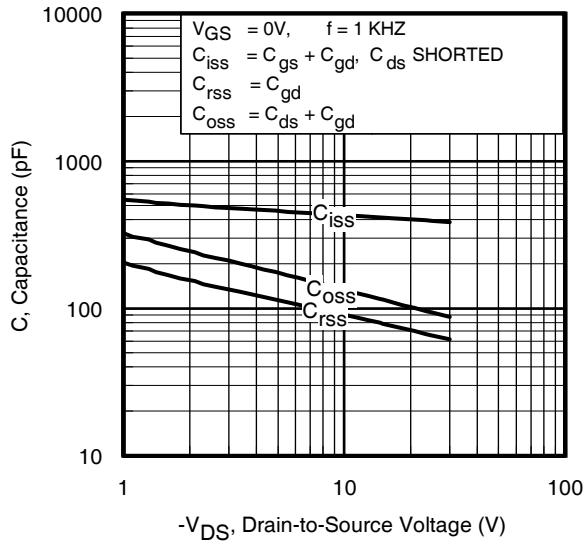
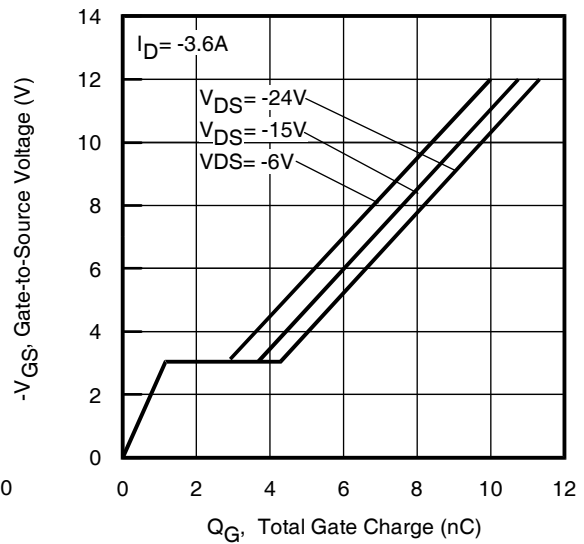

Fig 4. Normalized On-Resistance Vs. Temperature



**Fig 5.** Typical Capacitance Vs. Drain-to-Source Voltage



**Fig 6.** Typical Gate Charge Vs. Gate-to-Source Voltage

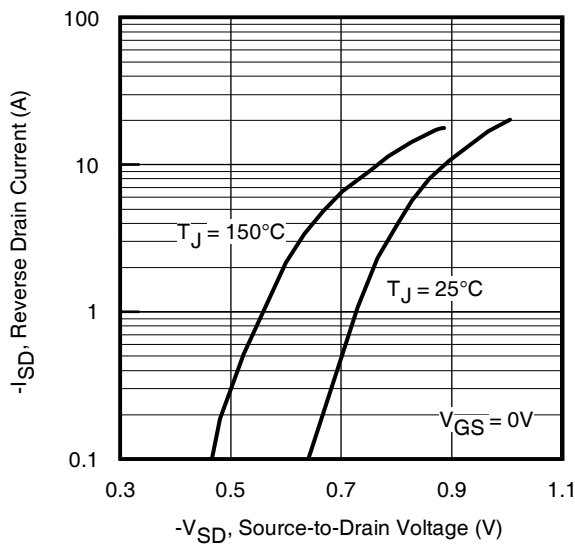

**Fig 7.** Typical Source-Drain Diode Forward Voltage

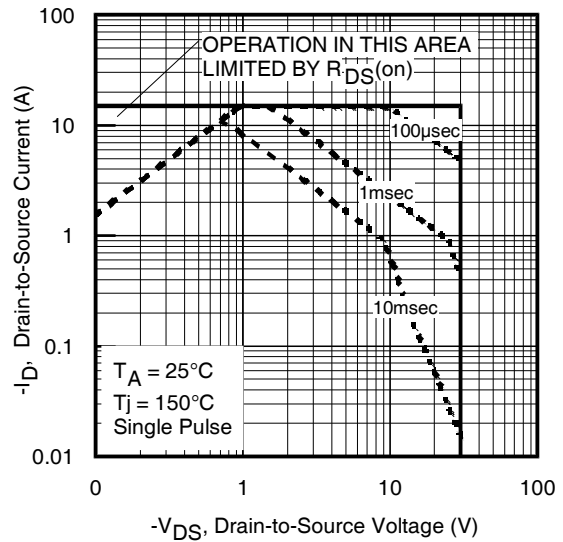

**Fig 8.** Maximum Safe Operating Area

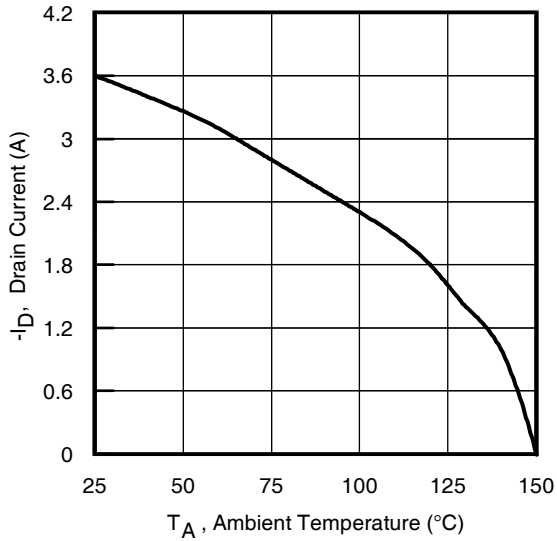

Fig 9. Maximum Drain Current Vs. Ambient Temperature

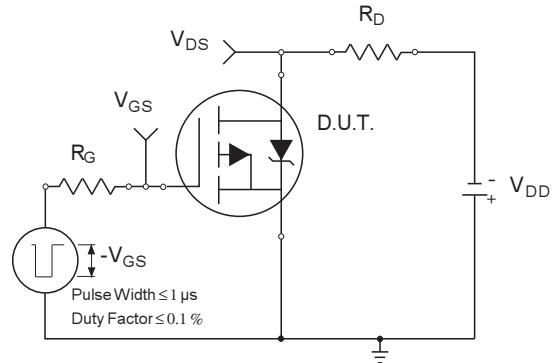

Fig 10a. Switching Time Test Circuit

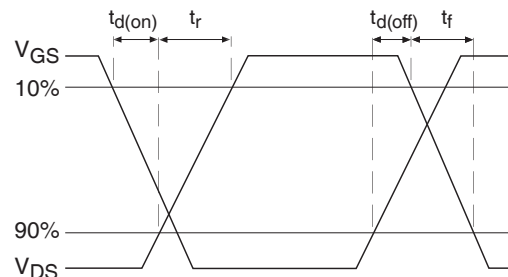

Fig 10b. Switching Time Waveforms

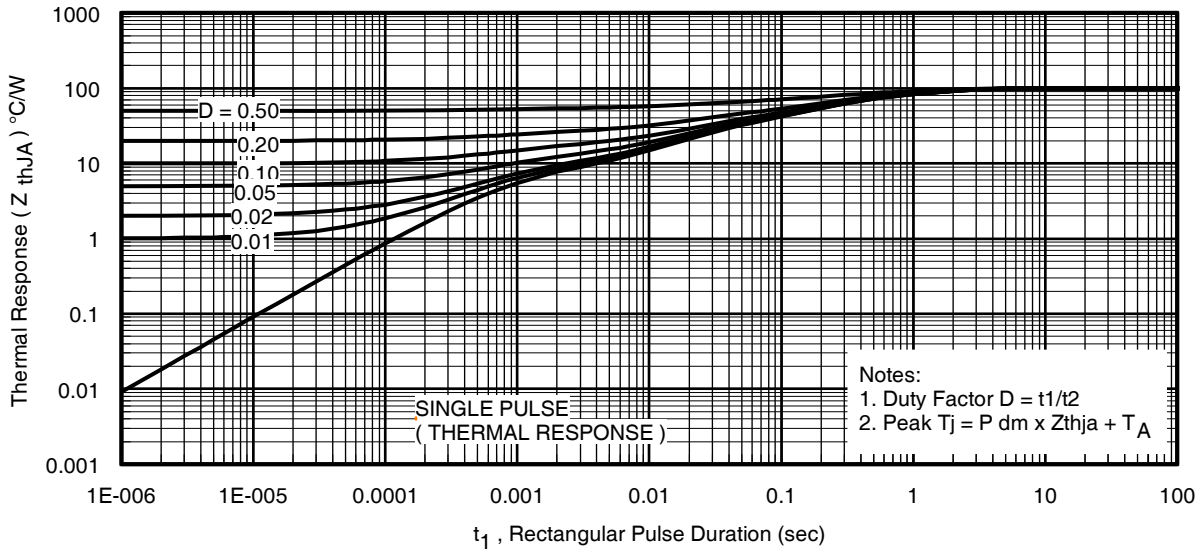

Fig 11. Typical Effective Transient Thermal Impedance, Junction-to-Ambient

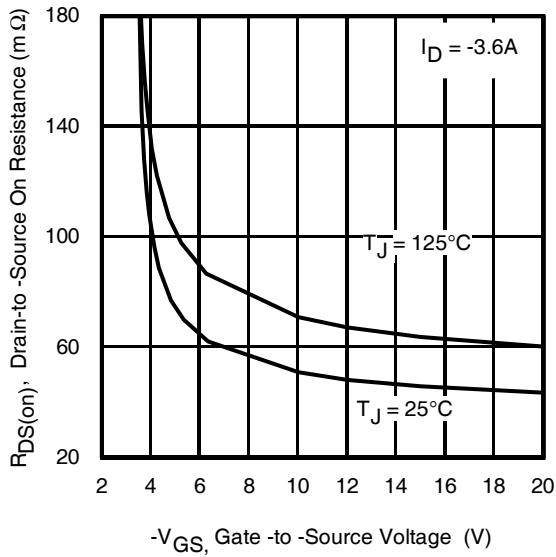

Fig 12. Typical On-Resistance Vs. Gate Voltage

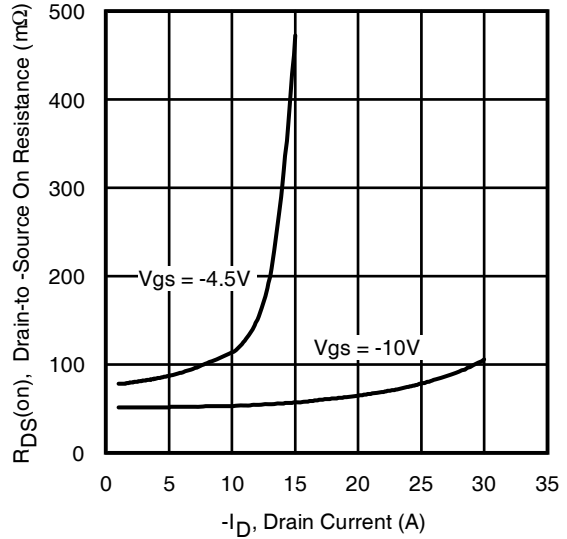

Fig 13. Typical On-Resistance Vs. Drain Current

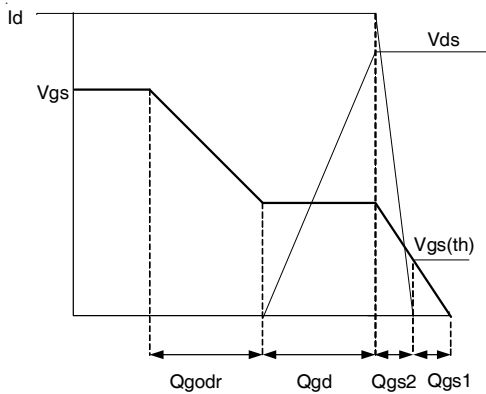

Fig 14a. Gate Charge Waveform

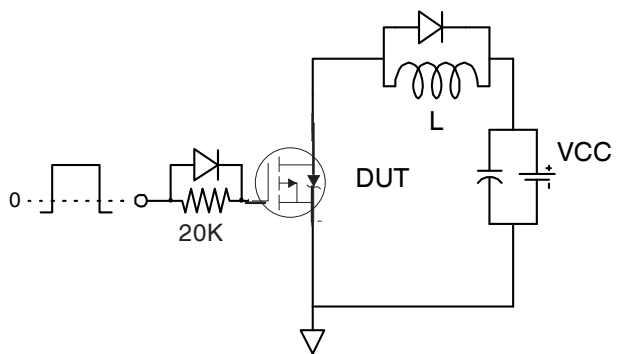

Fig 14b. Gate Charge Test Circuit

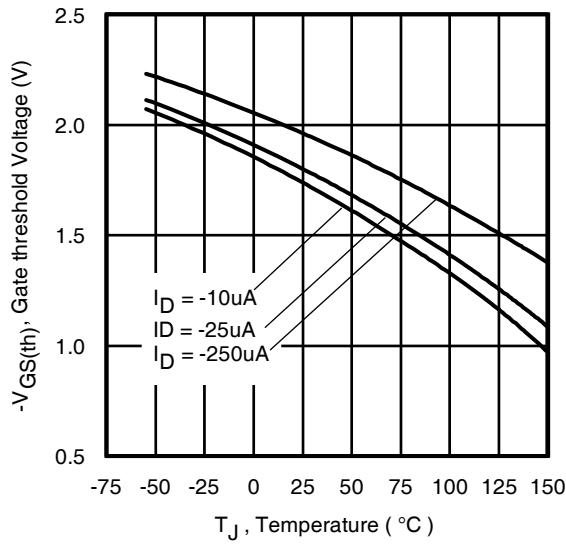

Fig 15. Typical Threshold Voltage Vs. Junction Temperature

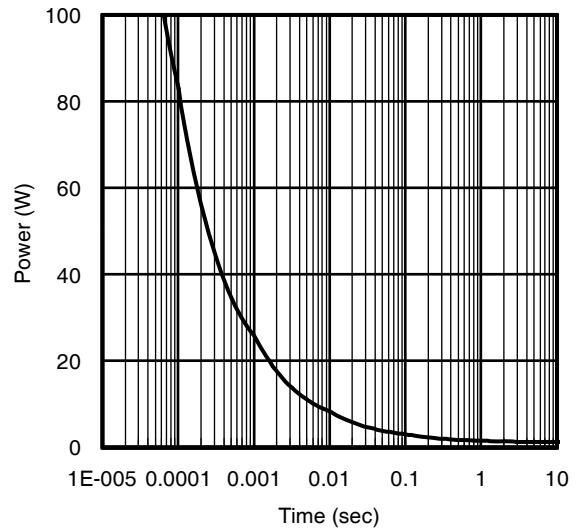
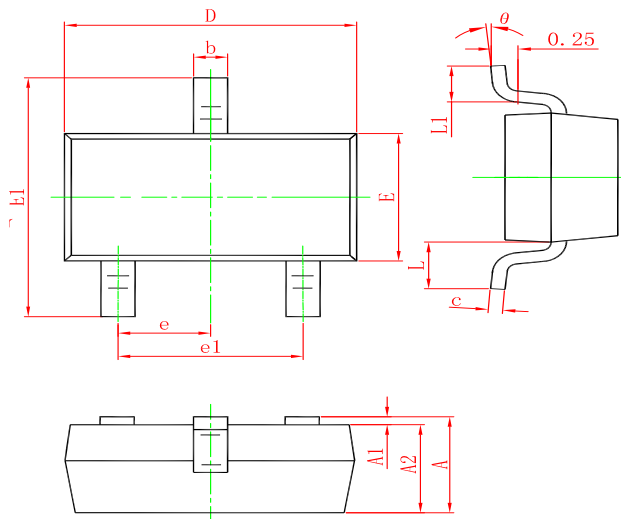

Fig 16. Typical Power Vs. Time

SOT-23 PACKAGE OUTLINE DIMENSIONS



| Symbol | Dimensions In Millimeters |       | Dimensions In Inches |       |
|--------|---------------------------|-------|----------------------|-------|
|        | Min.                      | Max.  | Min.                 | Max.  |
| A      | 0.900                     | 1.150 | 0.035                | 0.045 |
| A1     | 0.000                     | 0.100 | 0.000                | 0.004 |
| A2     | 0.900                     | 1.050 | 0.035                | 0.041 |
| b      | 0.300                     | 0.500 | 0.012                | 0.020 |
| c      | 0.080                     | 0.150 | 0.003                | 0.006 |
| D      | 2.800                     | 3.000 | 0.110                | 0.118 |
| E      | 1.200                     | 1.400 | 0.047                | 0.055 |
| E1     | 2.250                     | 2.550 | 0.089                | 0.100 |
| e      | 0.950 TYP.                |       | 0.037 TYP.           |       |
| e1     | 1.800                     | 2.000 | 0.071                | 0.079 |
| L      | 0.550 REF.                |       | 0.022 REF.           |       |
| L1     | 0.300                     | 0.500 | 0.012                | 0.020 |
| θ      | 0°                        | 8°    | 0°                   | 8°    |

Marking

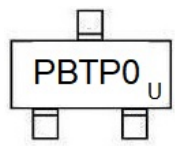

Ordering information

| Order code      | Package | Baseqty | Deliverymode  |
|-----------------|---------|---------|---------------|
| UMW IRLML9301TR | SOT-23  | 3000    | Tape and reel |



单击下面可查看定价，库存，交付和生命周期等信息

[>>UMW\(友台半导体\)](#)