

Features

- 60Watts peak pulse power ($t_p = 8/20\mu s$)
- Low clamping voltage
- Low leakage current
- Low capacitance ($C_j = 0.25pF$ typ.)
- Protection one data/power line
- IEC 61000-4-2 $\pm 15kV$ contact $\pm 20kV$ air
- IEC 61000-4-4 (EFT) 40A (5/50ns)
- IEC 61000-4-5 (Lightning) 3.5A (8/20 μs)

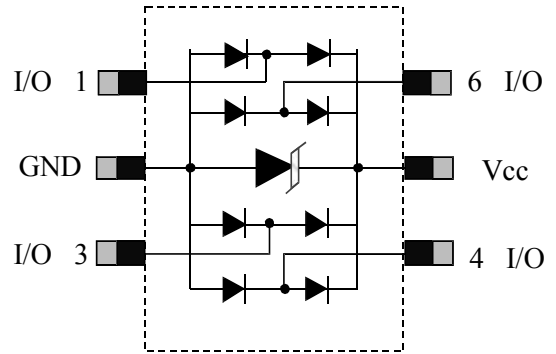

Applications

- Ethernet
- Digital Visual Interface (DVI)
- USB2.0
- Notebook and PC Computers

Absolute Maximum Rating

Rating	Symbol	Value	Units
Peak Pulse Power ($t_p=8/20\mu s$)	P_{PP}	60	Watts
Peak Pulse Current ($t_p=8/20\mu s$)(note1)	I_{pp}	3.5	A
ESD per IEC 61000-4-2 (Air) ESD per IEC 61000-4-2 (Contact)	V_{ESD}	20 15	kV
Lead Soldering Temperature	T_L	260(10seconds)	°C
Junction Temperature	T_J	-55 to + 125	°C
Storage Temperature	T_{stg}	-55 to + 125	°C

Electrical Characteristics

Parameter	Symbol	Conditions	Min	Typical	Max	Units
Reverse Stand-Off Voltage	V_{RWM}				5.0	V
Reverse Breakdown Voltage	V_{BR}	$I_T=1mA$	6			V
Reverse Leakage Current	I_R	$V_{RWM}=5V, T=25^\circ C$		50	500	nA
Peak Pulse Current	I_{PP}	$t_p = 8/20\mu s$			3	A
Clamping Voltage	V_C	$I_{PP}=3.5A, t_p=8/20\mu s$		15	18	V
Junction Capacitance	C_j	$V_R = 0V, f = 1MHz$ IO to IO		0.2	0.25	pF
		$V_R = 0V, f = 1MHz$ IO to GND		0.35	0.5	

Electrical Parameters (TA = 25°C unless otherwise noted)

Symbol	Parameter
I_{PP}	Maximum Reverse Peak Pulse Current
V_C	Clamping Voltage @ I_{PP}
V_{RWM}	Working Peak Reverse Voltage
I_R	Maximum Reverse Leakage Current @ V_{RWM}
V_{BR}	Breakdown Voltage @ I_T
I_T	Test Current

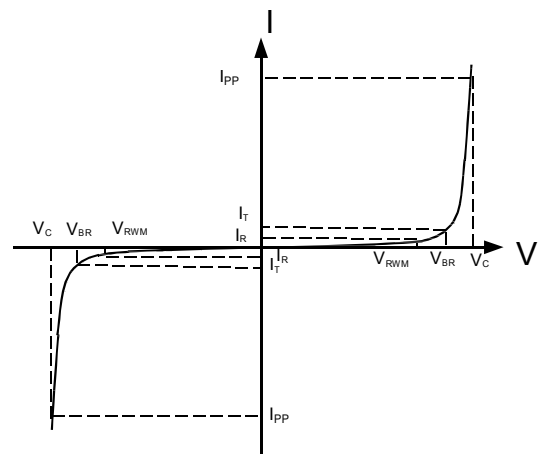

Typical Characteristic Curves

Fig.1 Peak Pulse Power Rating Curve

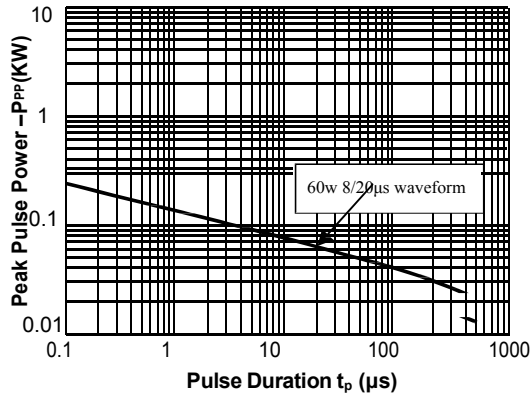

Fig.2 Pulse Derating Curve

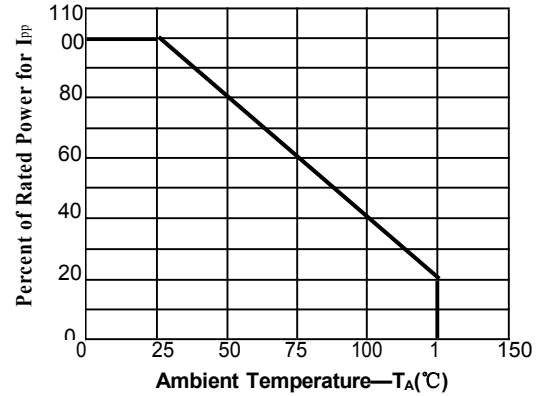

Fig.3 Pulse Waveform-8/20μs

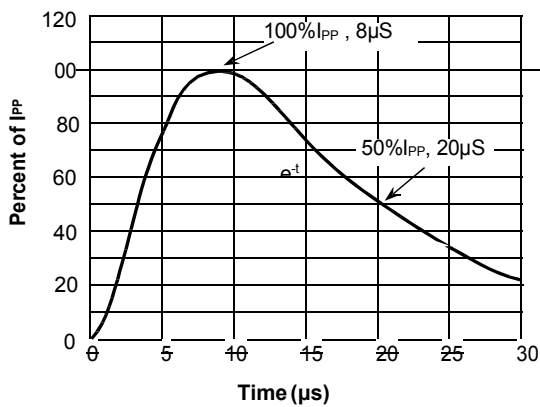

Fig.4 Pulse Waveform-ESD(IEC61000-4-2)

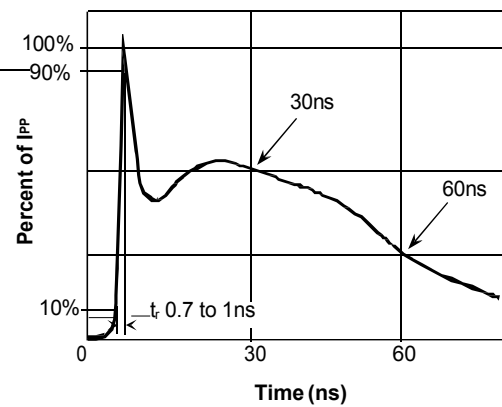
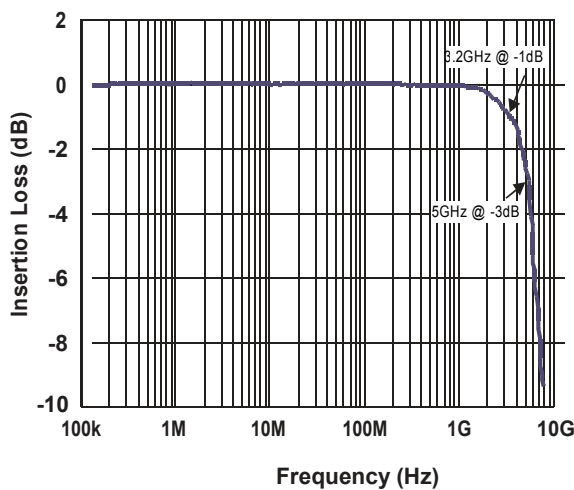
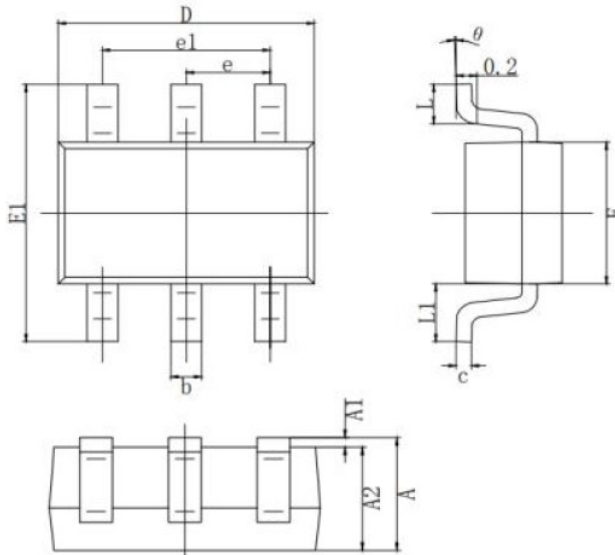

Fig.5 Insertion Loss S21 - I/O to GND



SOT-363 PACKAGE OUTLINE DIMENSIONS



SYMBOL	MILLIMETER	
	MIN	MAX
A	0.900	1.100
A1	0.000	0.100
A2	0.900	1.000
b	0.150	0.350
c	0.080	0.150
D	2.000	2.200
E	1.150	1.350
E1	2.150	2.450
e	0.650 TYP.	
e1	1.200	1.400
L	0.525 REF.	
L1	0.260	0.460
θ	0°	8°

Marking

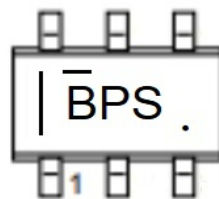

Ordering information

Order code	Package	Baseqty	Delivery mode
UMW TPD4E1U06DCKR	SOT-363	3000	Tape and reel

单击下面可查看定价，库存，交付和生命周期等信息

[>>UMW\(友台半导体\)](#)