

Features

- Fast switching MOSFET for SMPS
- Optimized technology for DC/DC converters
- Excellent gate charge x R_{DS(on)} product (FOM)
- Very low on-resistance R_{DS(on)}
- Avalanche rated

Product Summary

- V_{DS}= 30 V
- R_{DS(on),max}=13.5mΩ
- I_D =30A

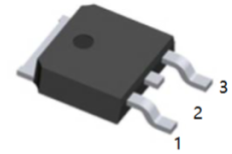

1.G 2.D 3.S
TO-252(DPAK) top view

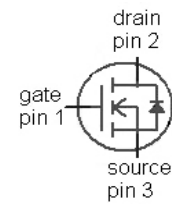

Maximum ratings, at T_J=25°C unless otherwise specified

Parameter	Symbol	Conditions	Value	Unit
Continuous drain current	I _D	V _{GS} =10 V, T _C =25 °C	30	A
		V _{GS} =10 V, T _C =100 °C	26	
		V _{GS} =4.5 V, T _C =25 °C	30	
		V _{GS} =4.5 V, T _C =100 °C	21	
Pulsed drain current ²⁾	I _{D,pulse}	T _C =25 °C	210	
Avalanche current single pulse ³⁾	I _{AS}	T _C =25 °C	30	
Avalanche energy, single pulse	E _{AS}	I _D =10 A, R _{GS} =25 Ω	20	mJ
Reverse diode dv/dt	dv/dt	I _D =30 A, V _{DS} =24 V, di/dt=200 A/μs, T _{j,max} =175 °C	6	kV/μs
Gate source voltage	V _{GS}		±20	V

¹⁾ J-STD20 and JESD22

Maximum ratings, at $T_J=25^\circ\text{C}$ unless otherwise specified

Parameter	Symbol	Conditions	Value			Unit
Power dissipation	P_{tot}	$T_C=25^\circ\text{C}$	31			W
Operating and storage temperature	T_j, T_{stg}		-55-175			$^\circ\text{C}$
IEC climatic category; DIN IEC 68-1			55/175/56			
Parameter	Symbol	Conditions	Values			Unit
			min.	typ.	max.	

Thermal characteristics

Thermal resistance, junction - case	R_{thJC}				4.9	K/W
SMD version, device on PCB	R_{thJA}	minimal footprint			75	
		6 cm ² cooling area ⁴⁾			50	

Electrical characteristics , at $T_J=25^\circ\text{C}$, unless otherwise specifice

Static characteristics

Drain-source breakdown voltage	$V_{(BR)DSS}$	$V_{GS}=0\text{ V}, I_D=1\text{ mA}$	30			V
Gate threshold voltage	$V_{GS(th)}$	$V_{DS}=V_{GS}, I_D=250\ \mu\text{A}$	1.0	1.7	2.5	
Zero gate voltage drain current	I_{DSS}	$V_{DS}=30\text{ V}, V_{GS}=0\text{ V}, T_J=25^\circ\text{C}$		0.1	1	μA
		$V_{DS}=30\text{ V}, V_{GS}=0\text{ V}, T_J=125^\circ\text{C}$		10	100	
Gate-source leakage current	I_{GSS}	$V_{GS}=20\text{ V}, V_{DS}=0\text{ V}$		10	100	nA
Drain-source on-state resistance ⁵⁾	$R_{DS(on)}$	$V_{GS}=4.5\text{ V}, I_D=20\text{ A}$		16.4	20.5	$\text{m}\Omega$
		$V_{GS}=10\text{ V}, I_D=30\text{ A}$		11.3	13.5	
Gate resistance	R_G			1.2		Ω
Transconductance	g_{fs}	$ V_{DS} > 2 I_D R_{DS(on)max}, I_D=30\text{ A}$	22	43		S

²⁾ See figure 3 for more detailed information

³⁾ See figure 13 for more detailed information

⁴⁾ Device on 40 mm x 40 mm x 1.5 mm epoxy PCB FR4 with 6 cm² (one layer, 70 μm thick) copper area for drain connection. PCB is vertical in still air.

⁵⁾ Measured from drain tab to source pin

Parameter	Symbol	Conditions	Values			Unit
			min.	typ.	max.	
Dynamic characteristics						
Input capacitance	C_{iss}	$V_{GS}=0\text{ V}, V_{DS}=15\text{ V},$ $f=1\text{ MHz}$		770	1000	pF
Output capacitance	C_{oss}			350	470	
Reverse transfer capacitance	C_{rss}			16		
Turn-on delay time	$t_{d(on)}$	$V_{DD}=15\text{ V}, V_{GS}=10\text{ V},$ $I_D=30\text{ A}, R_G=1.6\ \Omega$		3.0		ns
Rise time	t_r			3.0		
Turn-off delay time	$t_{d(off)}$			12		
Fall time	t_f			2.2		
Gate Charge Characteristics⁶⁾						
Gate to source charge	Q_{gs}	$V_{DD}=15\text{ V}, I_D=30\text{ A},$ $V_{GS}=0\text{ to }4.5\text{ V}$		2.7		nC
Gate charge at threshold	$Q_{g(th)}$			1.2		
Gate to drain charge	Q_{gd}			1.2		
Switching charge	Q_{sw}			2.6		
Gate charge total	Q_g			4.8	6.4	
Gate plateau voltage	$V_{plateau}$			3.5		
Gate charge total	Q_g	$V_{DD}=15\text{ V}, I_D=30\text{ A},$ $V_{GS}=0\text{ to }10\text{ V}$		10		nC
Gate charge total, sync. FET	$Q_{g(sync)}$	$V_{DS}=0.1\text{ V},$ $V_{GS}=0\text{ to }4.5\text{ V}$		4.2	5.5	
Output charge	Q_{oss}	$V_{DD}=15\text{ V}, V_{GS}=0\text{ V}$		9		
Reverse Diode						
Diode continuous forward current	I_S	$T_C=25\text{ }^\circ\text{C}$			25	A
Diode pulse current	$I_{S,pulse}$				210	
Diode forward voltage	V_{SD}	$V_{GS}=0\text{ V}, I_F=30\text{ A},$ $T_J=25\text{ }^\circ\text{C}$		0.98	1.2	V
Reverse recovery charge	Q_{rr}	$V_R=15\text{ V}, I_F=I_S,$ $d_F I dt=400\text{ A}\mu\text{s}$			10	nC

⁶⁾ See figure 16 for gate charge parameter definition

1 Power dissipation

$P_{tot}=f(T_c)$

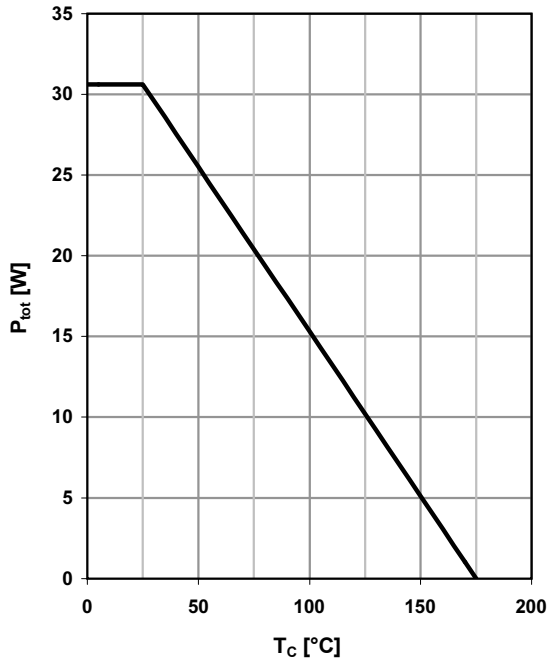

2 Drain current

$I_D=f(T_c); V_{GS} \geq 10V$

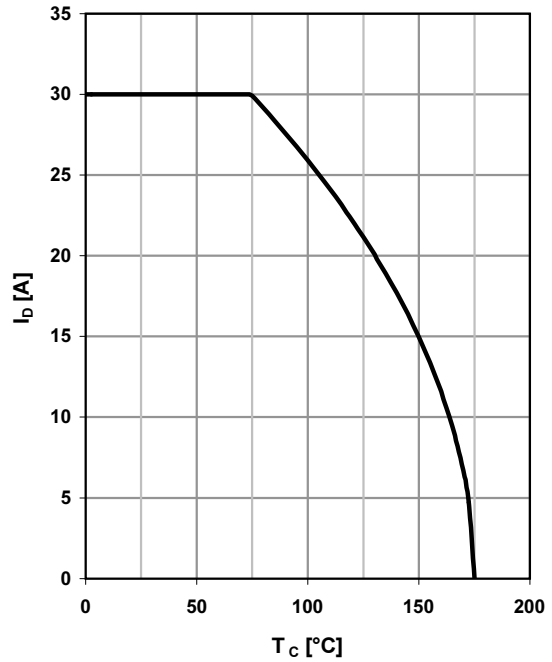

3 Safe operating area

$I_D=f(V_{DS}); T_c=25^\circ C; D=0$

parameter: t_p

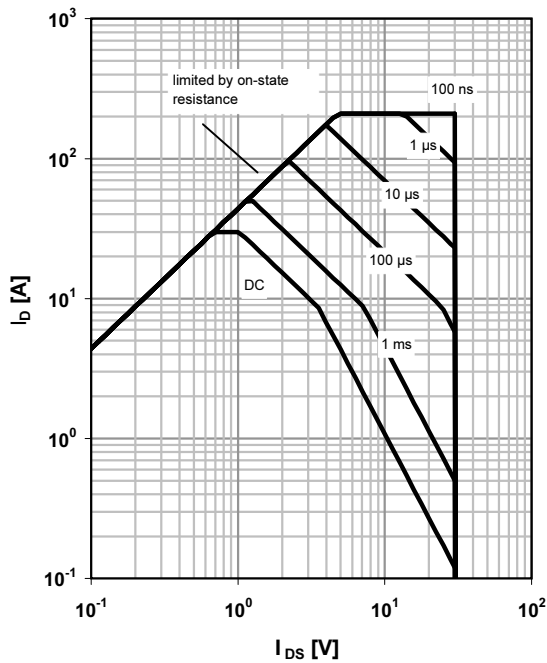

4 Max. transient thermal impedance

$Z_{thJC}=f(t_p)$

parameter: $D=t_p/T$

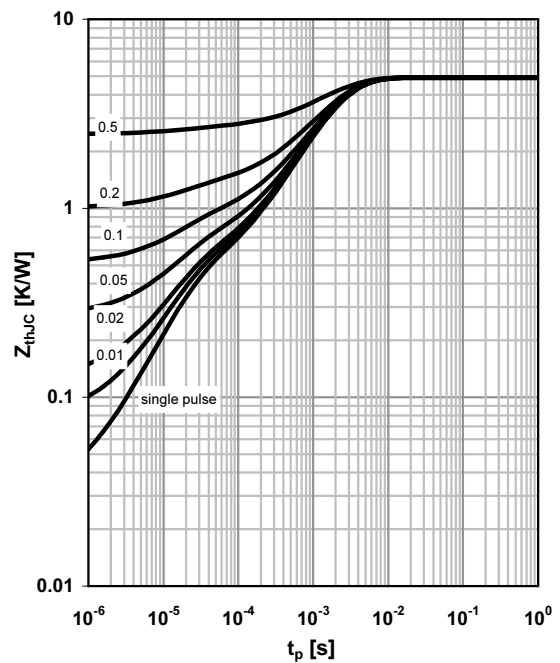

5 Typ. output characteristics

$I_D = f(V_{DS}); T_j = 25\text{ }^\circ\text{C}$

parameter: V_{GS}

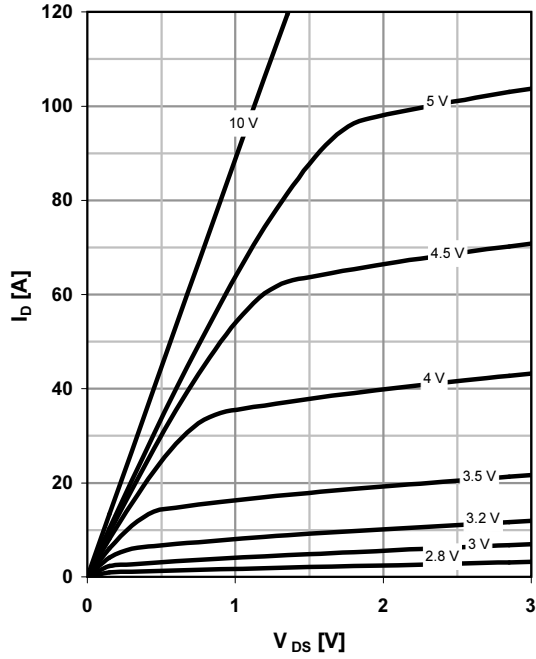

6 Typ. drain-source on resistance

$R_{DS(on)} = f(I_D); T_j = 25\text{ }^\circ\text{C}$

parameter: V_{GS}

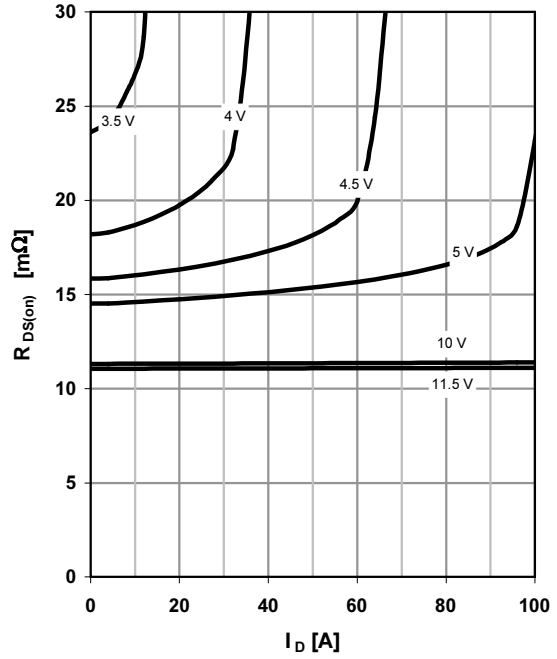

7 Typ. transfer characteristics

$I_D = f(V_{GS}); |V_{DS}| > 2|I_D|R_{DS(on)max}$

parameter: T_j

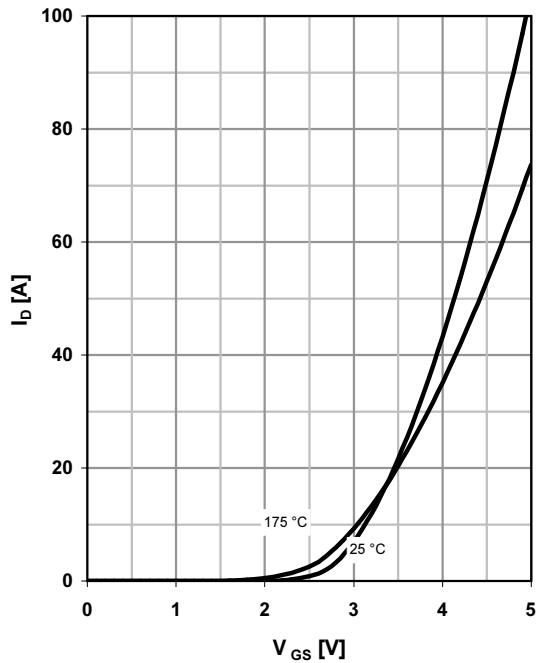

8 Typ. forward transconductance

$g_{fs} = f(I_D); T_j = 25\text{ }^\circ\text{C}$

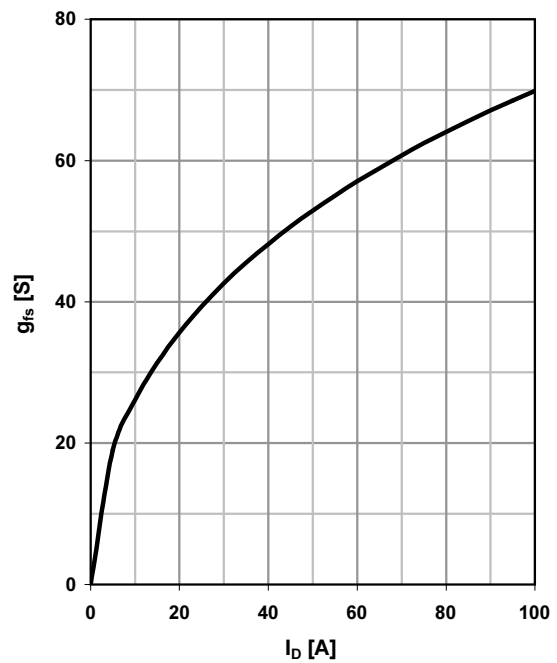

9 Drain-source on-state resistance

$R_{DS(on)} = f(T_j)$; $I_D = 30\text{ A}$; $V_{GS} = 10\text{ V}$

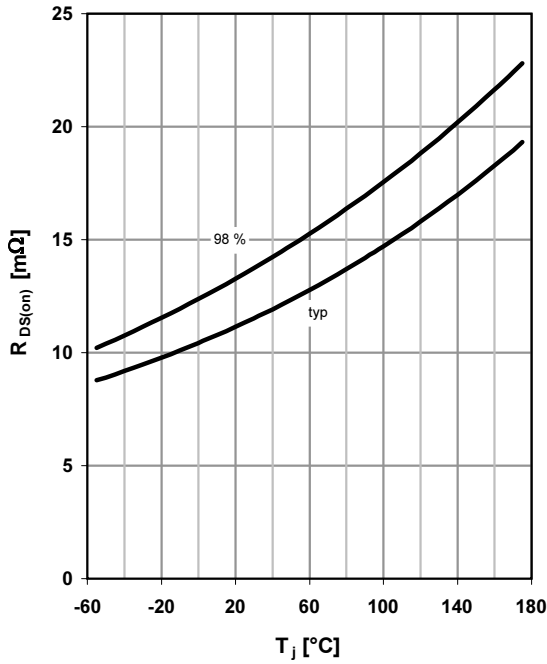

10 Typ. gate threshold voltage R

$V_{GS(th)} = f(T_j)$; $V_{GS} = V_{DS}$; $I_D = 250\ \mu\text{A}$

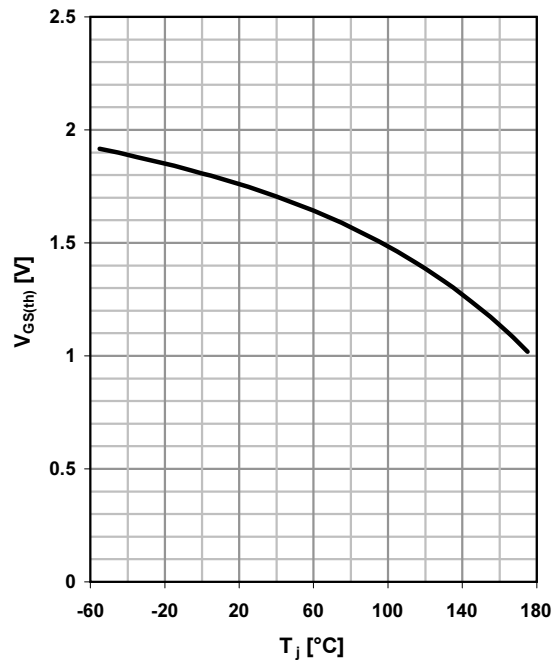

11 Typ. capacitances

$C = f(V_{DS})$; $V_{GS} = 0\text{ V}$; $f = 1\text{ MHz}$

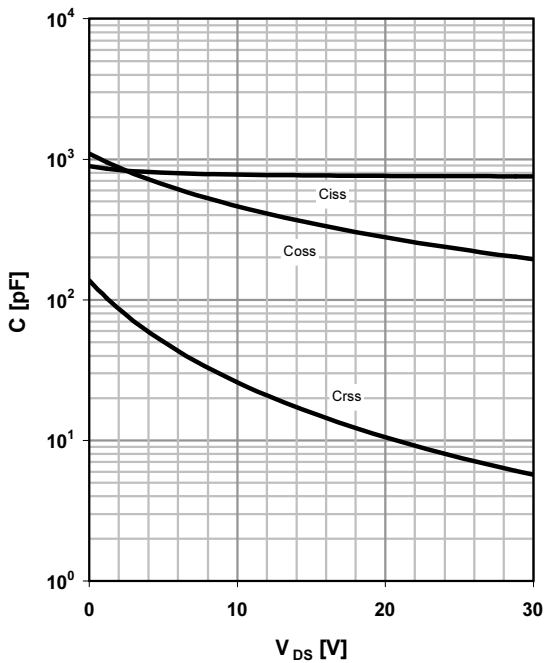

12 Forward characteristics of reverse diode

$I_F = f(V_{SD})$

parameter: T_j

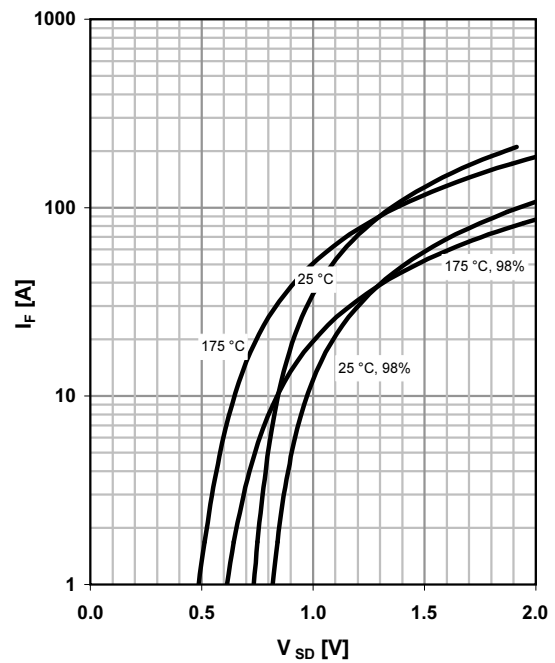

13 Avalanche characteristics

$I_{AS}=f(t_{AV}); R_{GS}=25\ \Omega$

parameter: $T_{j(start)}$

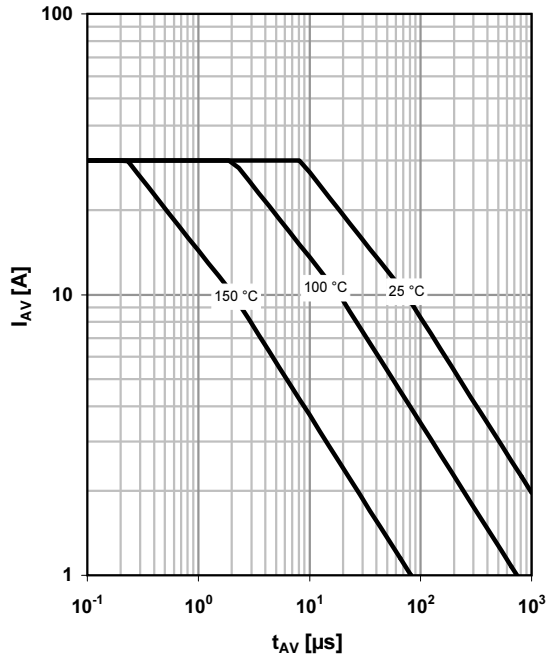

14 Typ. gate charge

$V_{GS}=f(Q_{gate}); I_D=30\text{ A pulsed}$

parameter: V_{DD}

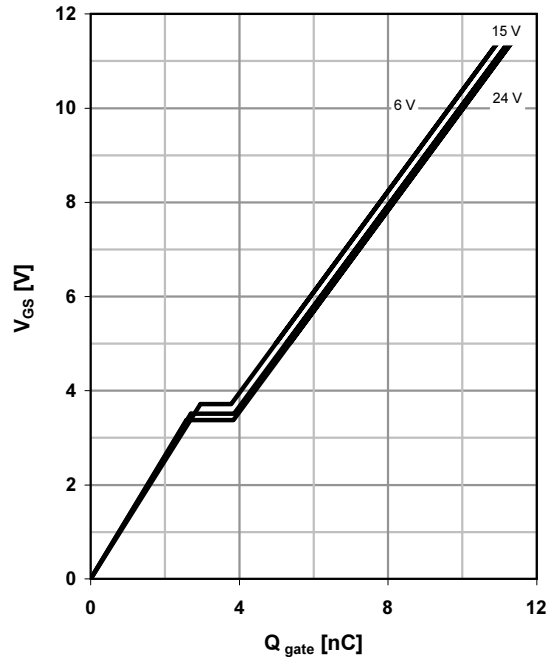

15 Drain-source breakdown voltage

$V_{BR(DSS)}=f(T_j); I_D=1\text{ mA}$

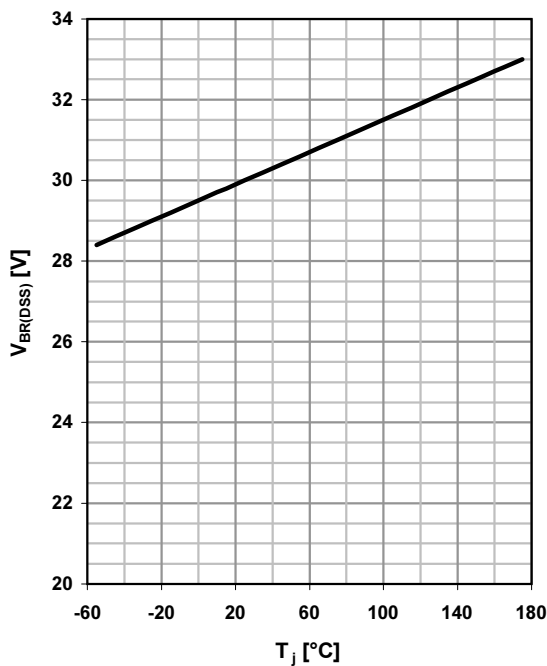

16 Gate charge waveforms

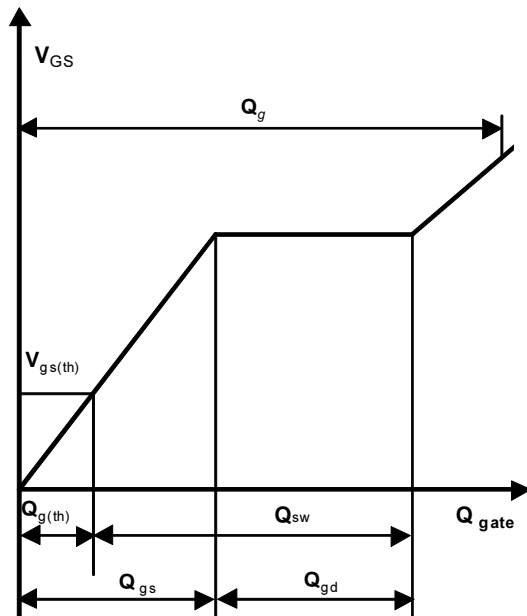

Package Mechanical Data TO-252

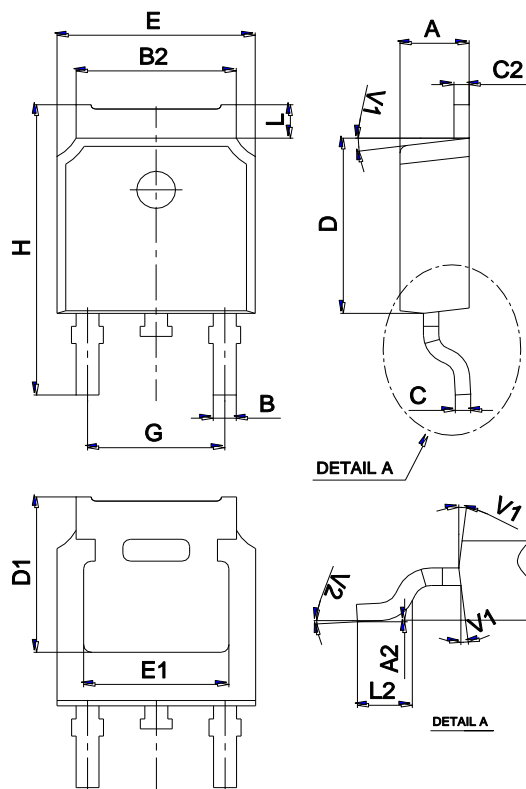

Ref.	Dimensions					
	Millimeters			Inches		
	Min.	Typ.	Max.	Min.	Typ.	Max.
A	2.10		2.50	0.083		0.098
A2	0		0.10	0		0.004
B	0.66		0.86	0.026		0.034
B2	5.18		5.48	0.202		0.216
C	0.40		0.60	0.016		0.024
C2	0.44		0.58	0.017		0.023
D	5.90		6.30	0.232		0.248
D1	5.30REF			0.209REF		
E	6.40		6.80	0.252		0.268
E1	4.63			0.182		
G	4.47		4.67	0.176		0.184
H	9.50		10.70	0.374		0.421
L	1.09		1.21	0.043		0.048
L2	1.35		1.65	0.053		0.065
V1		7°			7°	
V2	0°		6°	0°		6°

Marking

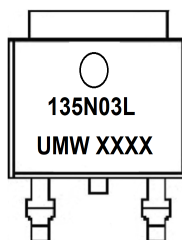

Ordering information

Order code	Package	Baseqty	Deliverymode
UMW IPD135N03LG	TO-252	2500	Tape and reel

单击下面可查看定价，库存，交付和生命周期等信息

[>>UMW\(友台半导体\)](#)