

Features

- 60Watts peak pulse power ($t_p = 8/20\mu s$)
- Low clamping voltage
- Low leakage current
- Low capacitance ($C_j=0.3pF$ typ. IO to IO)
- Protection one data/power line to:
- IEC 61000-4-2 $\pm 12kV$ contact $\pm 15kV$ air
- IEC 61000-4-4 (EFT) 40A(5/50ns)
- IEC 61000-4-5 (Lightning) 3.5A(8/20 μs)

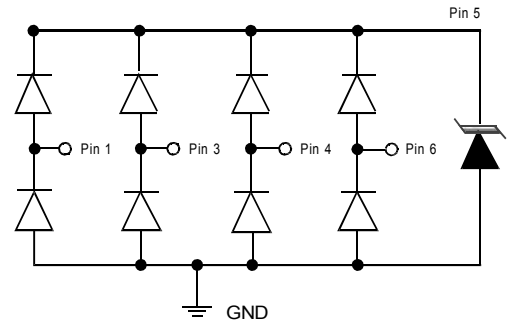

Applications

- Ethernet
- Digital Visual Interface (DVI)
- USB2.0
- Notebook and PC Computers

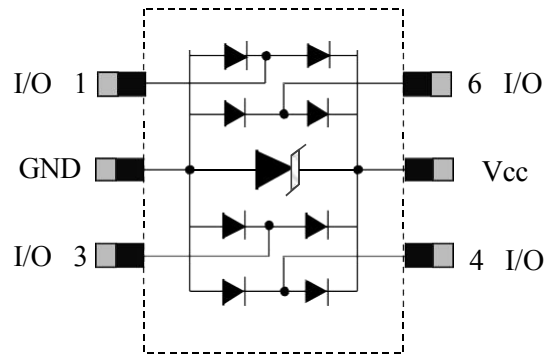

Absolute Maximum Rating

Rating	Symbol	Value	Units
Peak Pulse Power ($t_p=8/20\mu s$)	P_{PP}	60	Watts
Peak Pulse Current ($t_p=8/20\mu s$)(note1)	I_{pp}	3.5	A
ESD per IEC 61000-4-2 (Air) ESD per IEC 61000-4-2 (Contact)	V_{ESD}	15 12	kV
Lead Soldering Temperature	T_L	260(10seconds)	°C
Junction Temperature	T_J	-55 to + 125	°C
Storage Temperature	T_{stg}	-55 to + 125	°C

Electrical Characteristics

Parameter	Symbol	Conditions	Min	Typical	Max	Units
Reverse Stand-Off Voltage	V_{RWM}				5.0	V
Reverse Breakdown Voltage	V_{BR}	$I_T=1mA$	6	7.8	8.5	V
Reverse Leakage Current	I_R	$V_{RWM}=5V, T=25^\circ C$		50	500	nA
Peak Pulse Current	I_{PP}	$t_p=8/20\mu s$			3.5	A
Clamping Voltage	V_C	$I_{PP}=3.5A, t_p=8/20\mu s$		10	13	V
Junction Capacitance	C_j	$V_R=0V, f=1MHz$ IO to IO		0.2	0.25	pF
		$V_R=0V, f=1MHz$ IO to GND		0.36	0.5	

Electrical Parameters (TA=25°C unless otherwise noted)

Symbol	Parameter
I_{PP}	Maximum Reverse Peak Pulse Current
V_C	Clamping Voltage @ I_{PP}
V_{RWM}	Working Peak Reverse Voltage
I_R	Maximum Reverse Leakage Current @ V_{RWM}
V_{BR}	Breakdown Voltage @ I_T
I_T	Test Current

Note: .8/20μs pulse waveform.

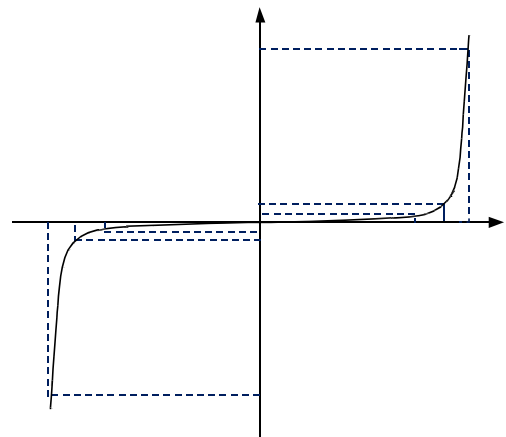

Typical Characteristic Curves

Fig.1 Peak Pulse Power Rating Curve

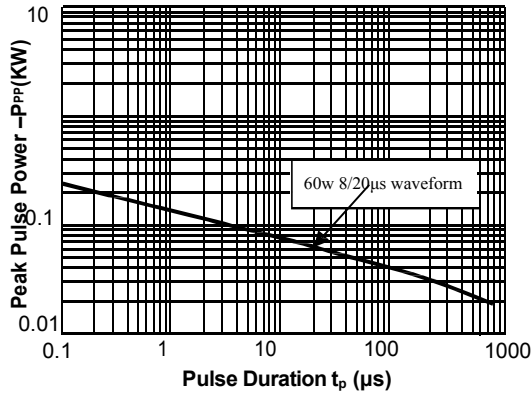

Fig.2 Pulse Derating Curve

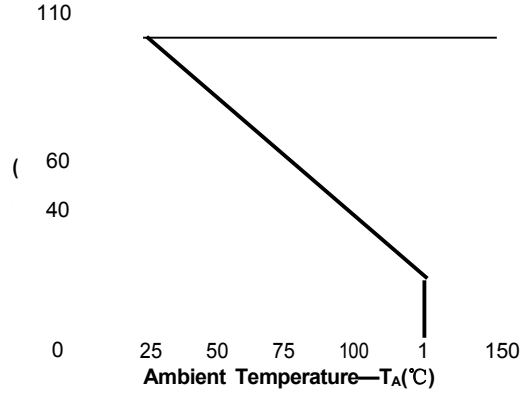

Fig.3 PulseWaveform-8/20μs

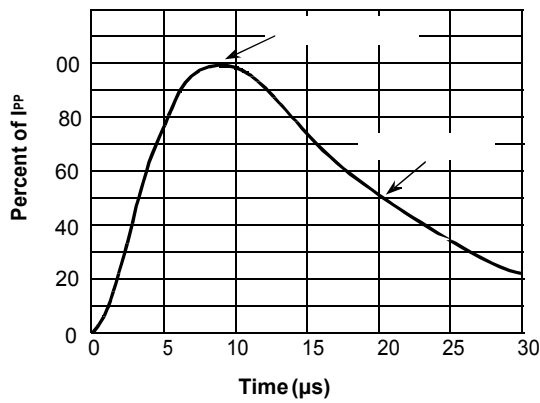

Fig.4 PulseWaveform-ESD(IEC61000-4-2)

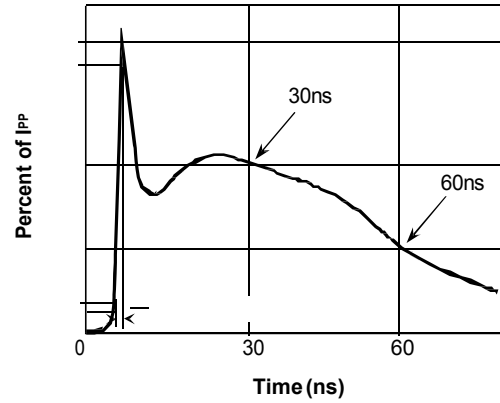
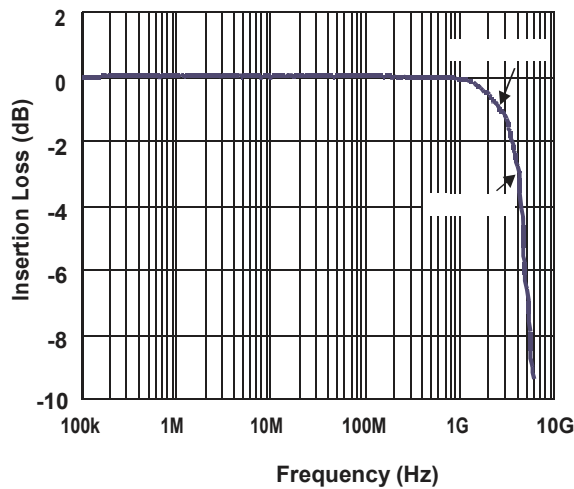
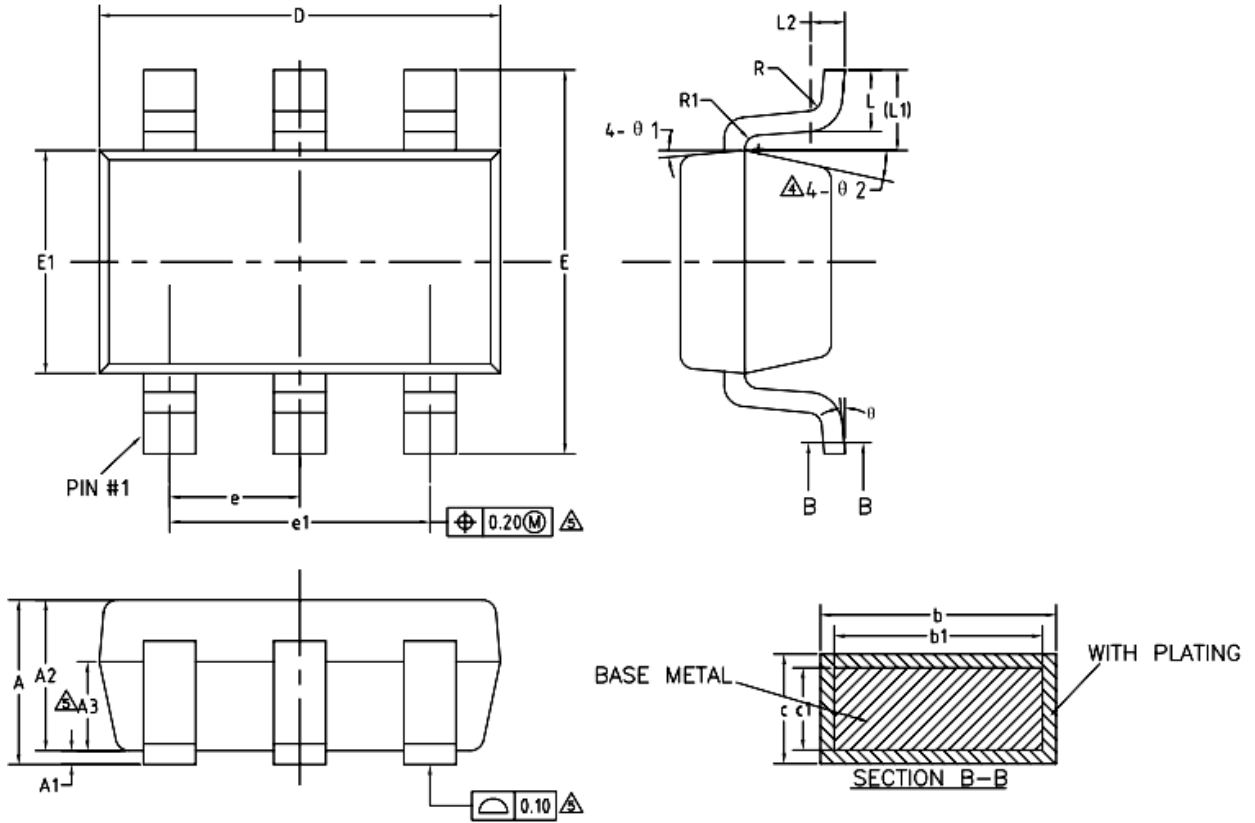

Fig.5 Insertion Loss S21 - I/O to GND



SOT23-6



COMMON DIMENSIONS
(UNITS OF MEASURE=MILLIMETER)

SYMBOL	MIN	NOM	MAX
A	—	—	1.25
A1	0	—	0.15
A2	1.00	1.10	1.20
A3	0.60	0.65	0.70
b	0.36	—	0.50
b1	0.36	0.38	0.45
c	0.14	—	0.20
c1	0.14	0.15	0.16
D	2.826	2.926	3.026
E	2.60	2.80	3.00
E1	1.526	1.626	1.726
e	0.90	0.95	1.00
e1	1.80	1.90	2.00
L	0.35	0.45	0.60
L1	0.59REF		
L2	0.25BSC		
R	0.10	—	—
R1	0.10	—	0.20
θ	0°	—	8°
θ 1	3°	5°	7°
θ 2	6°	—	14°

Marking



Ordering information

Order code	Package	Base qty	Delivery mode
UMW NUP4114HMR6T1G	SOT23-6	3000	Tape and reel

单击下面可查看定价，库存，交付和生命周期等信息

[>>UMW\(友台半导体\)](#)