

Description

AZC199-02S is a design which includes ESD rated diode arrays to protect high speed data interfaces. The AZC199-02S has been specifically designed to protect sensitive components which are connected to data and transmission lines from over-voltage caused by Electrostatic Discharging (ESD).

AZC199-02S includes ESD rated, low capacitance steering diodes and a unique design of clamping cell which is an equivalent TVS diode in a single package. During transient conditions, the steering diodes direct the transient to ground line. The internal unique design of clamping cell prevents over-voltage on the data line, protecting any downstream components.

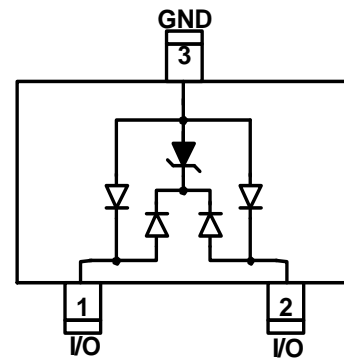
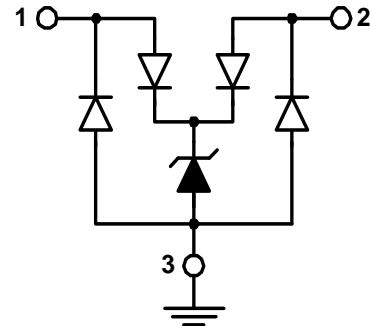

Features

- ESD Protect for 2 high-speed I/O lines
- Provide ESD protection for each line to IEC 61000-4-2,(ESD) (contact/air) ±16kV IEC 61000-4-4 (EFT) Level-3, 55A (5/50ns) IEC 61000-4-5 (Lightning) 5A (8/20µs)
- For low operating voltage applications: 5V, 4.2V, 3.3V, 2.5V etc.
- Low capacitance : 1.6pF typical
- Fast turn-on and Low clamping voltage
- Array of ESD rated diodes with internal equivalent TVS diode
- Solid-state silicon-avalanche and active circuit triggering technology
- Green part

Applications

- Video Graphics Cards
- Digital Visual Interface (DVI)
- USB2.0 Power and Data lines protection
- Notebook and PC Computers
- Monitors and Flat Panel Displays

ABSOLUTE MAXIMUM RATINGS

PARAMETER	SYMBOL	RATING	UNITS
Peak Pulse Current (tp =8/20μs)	I _{PP}	5	A
Operating Supply Voltage	V _{DC}	6	V
ESD per IEC 61000-4-2 (Air/Contact)	V _{ESD}	±16	kV
Lead Soldering Temperature	T _{SOL}	260 (10 sec.)	°C
Operating Temperature	T _{OP}	-55 to +85	°C
Storage Temperature	T _{STO}	-55 to +150	°C
DC Voltage at any I/O pin	V _{IO}	(GND – 0.5) to 5.5	V

ELECTRICAL CHARACTERISTICS

PARAMETER	SYMBOL	CONDITIONS	MIN	TYP	MAX	UNITS
Reverse Stand-Off Voltage	V _{RWM}	Pin 1/2 to Pin3, T=25 °C			5	V
Leakage Current	I _{Leak}	V _{pin1 or pin2} = 5V, V _{Pin3} = 0V, T=25 °C			1	μA
Reverse Breakdown Voltage	V _{BV}	I _{BV} = 1mA, T=25 °C, Pin 1/2 to Pin 3	7		10	V
Forward Voltage	V _F	I _F = 15mA, T=25 °C, Pin 3 to Pin1/2		0.85	1.1	V
ESD Clamping Voltage	V _{clamp}	IEC 61000-4-2 +6kV, T=25 °C, Contact mode, Pin 1/2 to Pin 3		11		V
ESD Dynamic Turn on Resistance	R _{dynamic}	IEC 61000-4-2 0~+6kV, T=25 °C, Contact mode, Pin 1/2 to Pin 3		0.3		Ω
Lightning Clamping Voltage	V _{lightning}	I _{PP} =5A, tp=8/20μs, T=25 °C Pin 1/2 to Pin 3		8.5		V
Channel Input Capacitance	C _{IN}	V _{pin3} =0V, V _{pin1 or 2} =2.5V, f=1MHz, T=25°C, Pin 1/2 to Pin 3		1.6	1.9	pF
Channel to Channel Input Capacitance	C _{CROSS}	V _{pin3} =0V, V _{pin1 or 2} =2.5V, f=1MHz, T=25°C, Between Pin 1 and Pin 2		0.23	0.28	pF
Variation of Channel Input Capacitance	ΔC _{IN}	V _{pin3} =0V, V _{pin1 or 2} =2.5V, f=1MHz, T=25°C, (Pin 1 to Pin 3)–(Pin 2 to Pin 3)		0.06	0.08	pF

Typical Characteristics

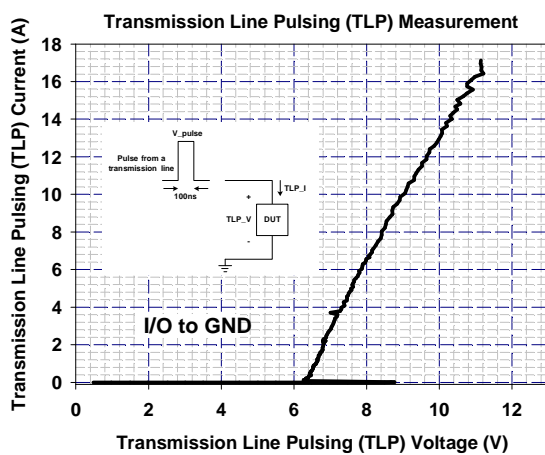
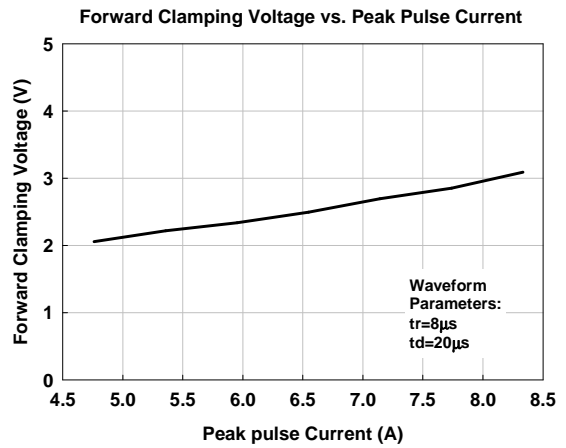
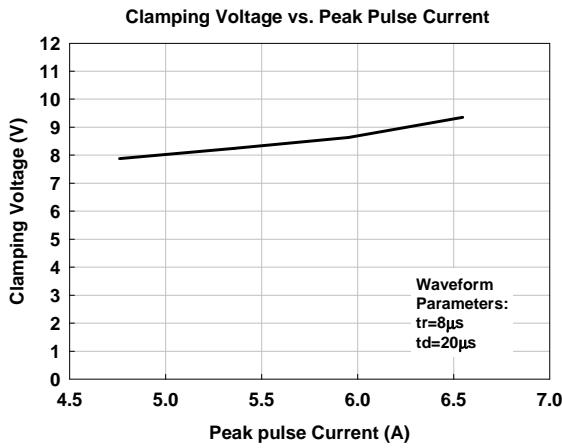
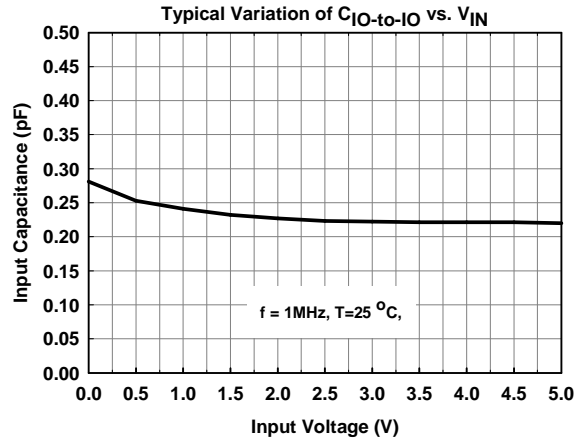
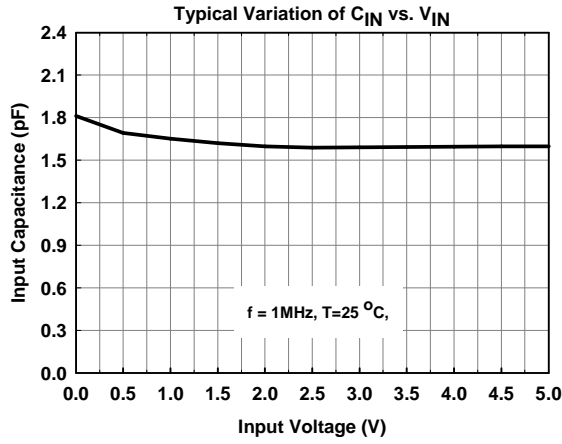

Applications Information

The AZC199-02S is designed to protect two lines against System ESD/EFT/Lightning pulses by clamping them to an acceptable reference.

The usage of the AZC199-02S is shown in Fig. 1. Protected lines, such as data lines, control lines, or power lines, are connected at pin 1 and 2. The pin 3 should be connected directly to a ground plane on the board. All path lengths connected to the pins of AZC199-02S should be kept as short as possible to minimize parasitic inductance in the board traces.

In order to obtain enough suppression of ESD induced transient, good circuit board is critical.

Thus, the following guidelines are recommended:

- Minimize the path length between the protected lines and the AZC199-02S.
- Place the AZC199-02S near the input terminals or connectors to restrict transient coupling.
- The ESD current return path to ground should be kept as short as possible.
- Use ground planes whenever possible.
- NEVER route critical signals near board edges and near the lines which the ESD transient easily injects to.

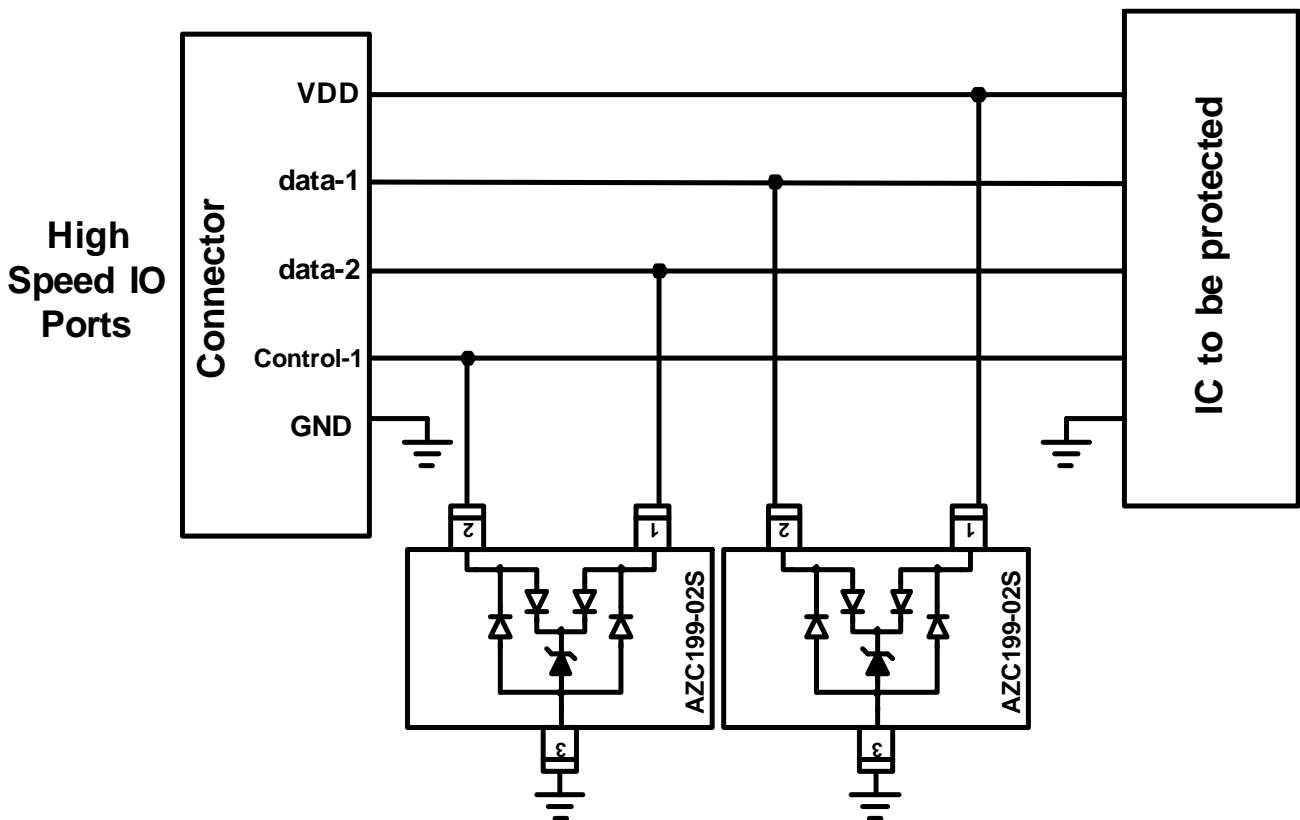

Fig. 1

Fig. 2 shows another simplified example of using transient stress. AZC199-02S to protect the control lines, high speed data lines, and power lines from ESD

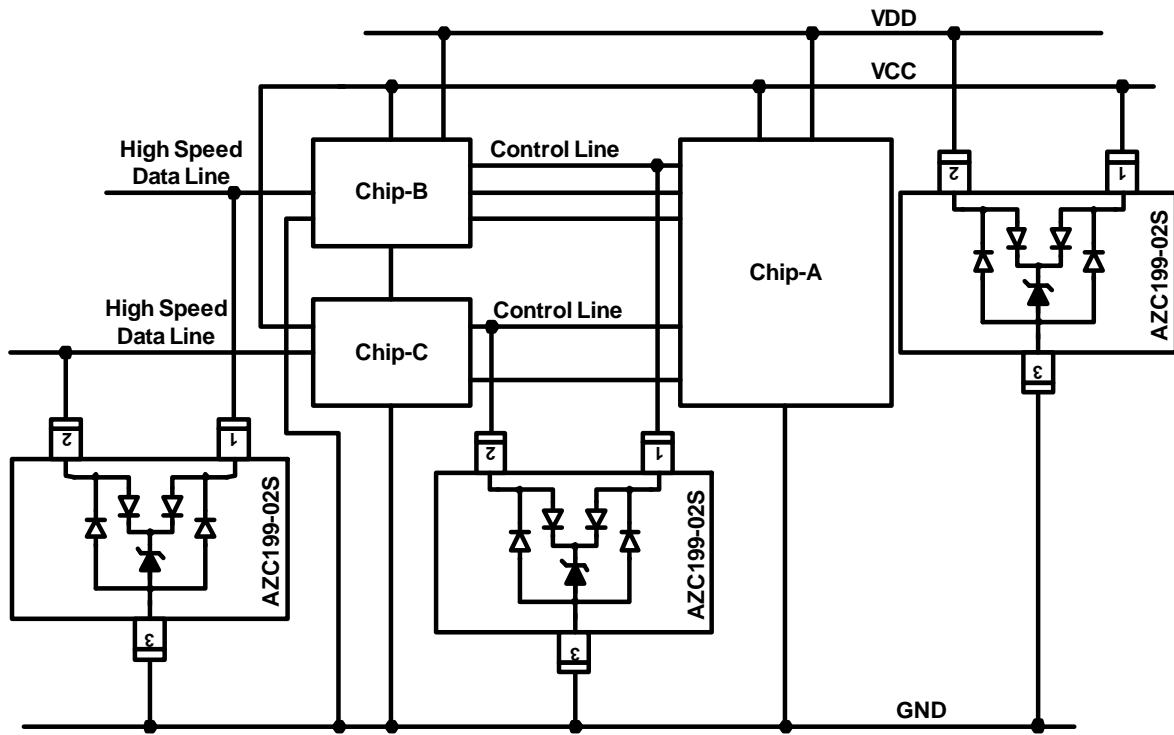
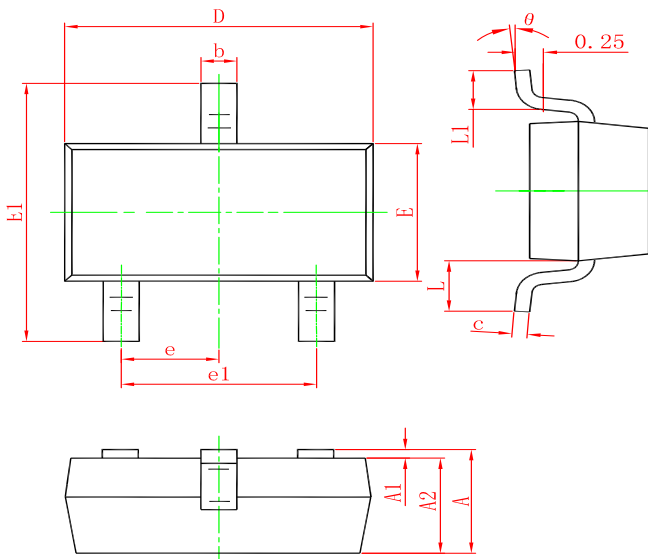

Fig. 2

SOT-23 PACKAGE OUTLINE DIMENSIONS



Symbol	Dimensions In Millimeters		Dimensions In Inches	
	Min.	Max.	Min.	Max.
A	0.900	1.150	0.035	0.045
A1	0.000	0.100	0.000	0.004
A2	0.900	1.050	0.035	0.041
b	0.300	0.500	0.012	0.020
c	0.080	0.150	0.003	0.006
D	2.800	3.000	0.110	0.118
E	1.200	1.400	0.047	0.055
E1	2.250	2.550	0.089	0.100
e	0.950 TYP.		0.037 TYP.	
e1	1.800	2.000	0.071	0.079
L	0.550 REF.		0.022 REF.	
L1	0.300	0.500	0.012	0.020
θ	0°	8°	0°	8°

Marking

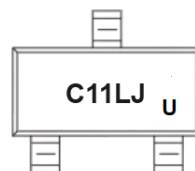

Ordering information

Order code	Package	Baseqty	Deliverymode
UMW AZC199-02S	SOT-23	3000	Tape and reel

单击下面可查看定价，库存，交付和生命周期等信息

[>>UMW\(友台半导体\)](#)