

## Description

AZ5125-01H is a design which includes a bi-directional ESD rated clamping cell to protect one power line, or one control line, or one low speed data line in an electronic systems. The AZ5125-01H has been specifically designed to protect sensitive components which are connected to power and control lines from over-voltage damage and latch-up caused by Electrostatic Discharging (ESD), Electrical Fast Transients (EFT), and Cable Discharge Event (CDE).

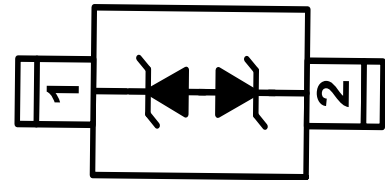

SOD-523 (Top View)

## Features

- ESD Protection for 1 Line with Bi-directional.
- Provide ESD protection for the protected line to IEC 61000-4-2 (ESD)  $\pm 20\text{kV}$  (air),  $\pm 15\text{kV}$  (contact)  
IEC 61000-4-4 (EFT) 50A (5/50ns)  
Cable Discharge Event (CDE)
- Ultra-small SOD-523 package saves board space.
- Protect one I/O line or one power line
- Fast turn-on and Low clamping voltage
- For low operating voltage applications: 5V maximum
- Solid-state silicon-avalanche and active circuit triggering technology
- Green Part

## Applications

- Computer Interfaces Protection
- Microprocessors Protection
- Serial and Parallel Ports Protection
- Control Signal Lines Protection
- Power lines on PCB Protection
- Latchup Protection

**SPECIFICATIONS**

ABSOLUTE MAXIMUM RATINGS			
PARAMETER	PARAMETER	RATING	UNITS
Operating Supply Voltage	$V_{DC}$	$\pm 6$	V
ESD per IEC 61000-4-2 (Air)	$V_{ESD}$	$\pm 20$	kV
ESD per IEC 61000-4-2 (Contact)		$\pm 15$	
Lead Soldering Temperature	$T_{SOL}$	260 (10 sec.)	$^{\circ}C$
Operating Temperature	$T_{OP}$	-55 to +85	$^{\circ}C$
Storage Temperature	$T_{STO}$	-55 to +150	$^{\circ}C$

ELECTRICAL CHARACTERISTICS						
PARAMETER	SYMBOL	CONDITIONS	MINI	TYP	MAX	UNITS
Reverse Stand-Off Voltage	$V_{RWM}$	$T=25^{\circ}C$ .	-5		5	V
Reverse Leakage Current	$I_{Leak}$	$V_{RWM} = \pm 5V, T=25^{\circ}C$ .			1	$\mu A$
Reverse Breakdown Voltage	$V_{BV}$	$I_{BV} = 1mA, T=25^{\circ}C$ .	6		9	V
ESD Clamping Voltage	$V_{ESD\_CL}$	IEC 61000-4-2 +6kV, $T=25^{\circ}C$ , Contact mode.		10		V
Channel Input Capacitance	$C_{IN}$	$V_R = 0V, f = 1MHz, T=25^{\circ}C$ .		7	9	pF

Typical Characteristics

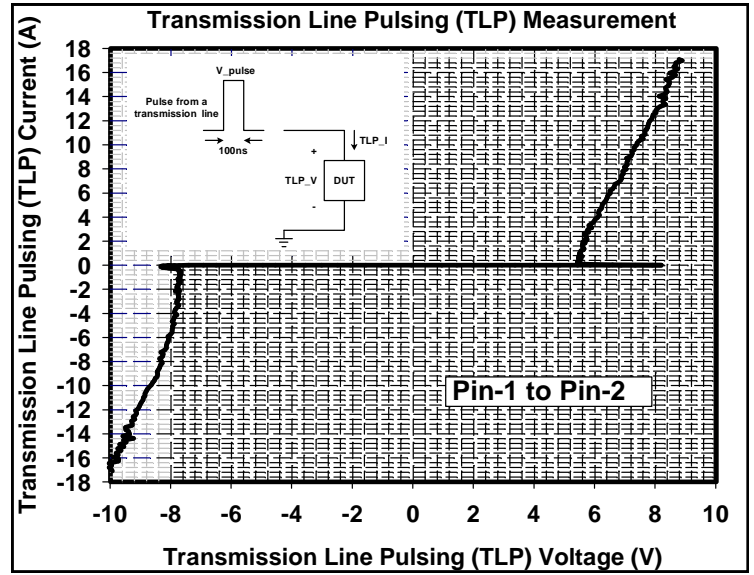
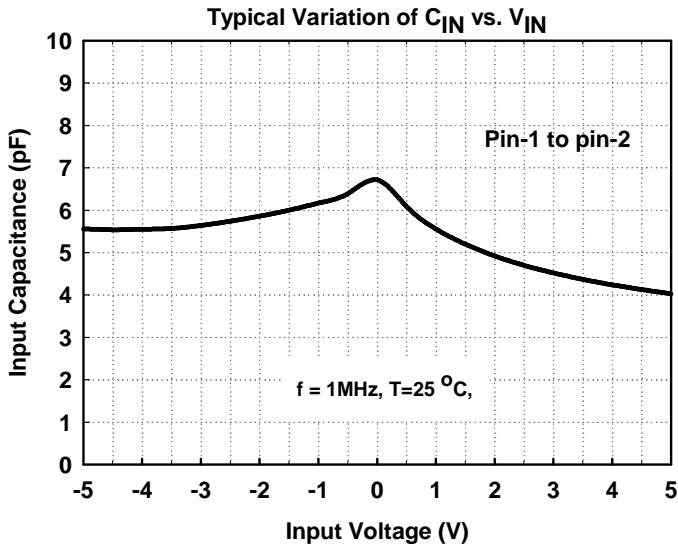

## Applications Information

The AZ5125-01H is designed to protect one line against System ESD/EFT/Cable-Discharge pulses by clamping them to an acceptable reference. It provides bi-directional protection.

The usage of the AZ5125-01H is shown in Fig. 1. Protected line, such as data lines, control lines, or power lines, is connected at pin 1. The pin 2 is connected to a ground plane on the board. Since AZ5125-01H is bi-directional, these connections can be reversed (protected line to pin 2, ground to pin 1). In order to minimize parasitic inductance in the board traces, all path lengths connected to the pins of AZ5125-01H should be kept as short as possible.

In order to obtain enough suppression of ESD induced transient, good circuit board is critical.

Thus, the following guidelines are recommended:

- Minimize the path length between the protected lines and the AZ5125-01H.
- Place the AZ5125-01H near the input terminals or connectors to restrict transient coupling.
- The ESD current return path to ground should be kept as short as possible.
- Use ground planes whenever possible.
- NEVER route critical signals near board edges and near the lines which the ESD transient easily injects to.

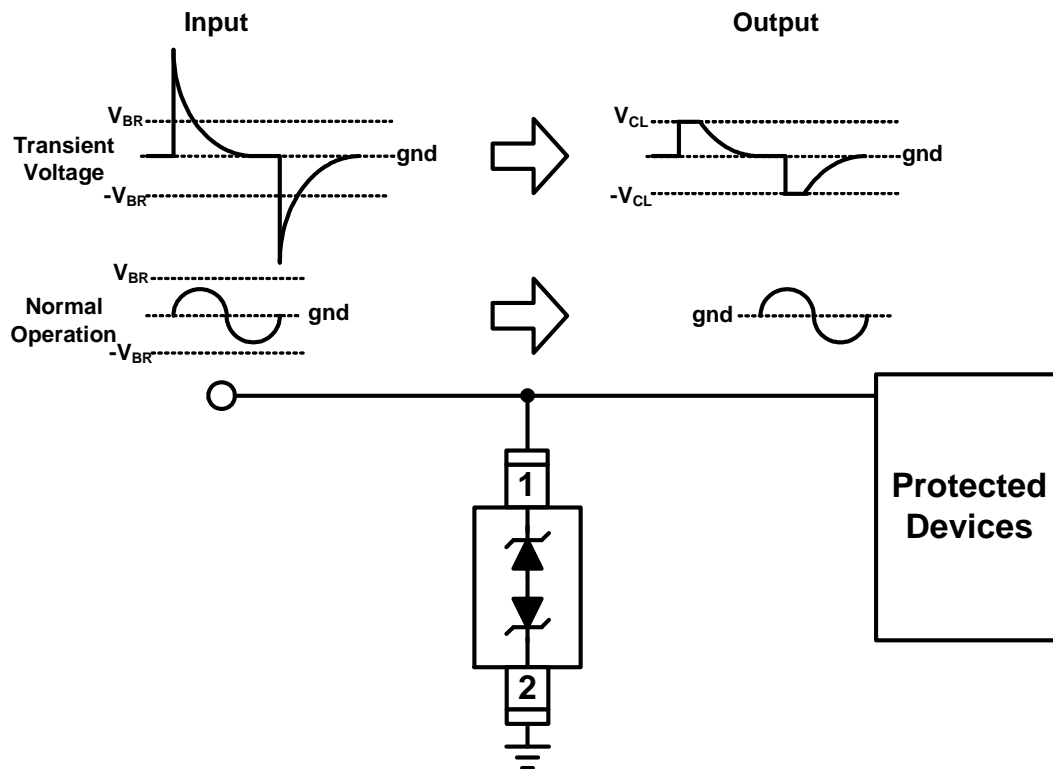
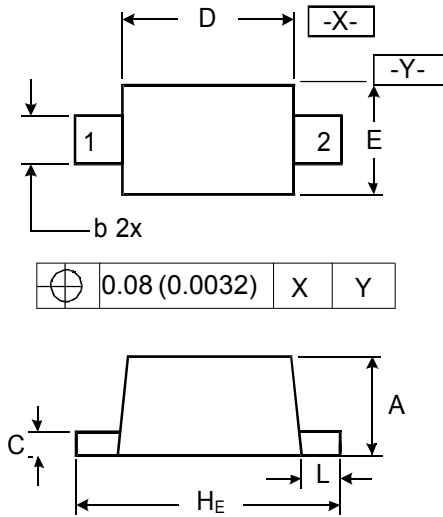

Fig. 1

**Package outline dimensions**

**SOD-523**



**DIMENSIONS**

SYMBOL	MILLIMETER		INCHES	
	MIN	MAX	MIN	MAX
A	0.50	0.70	0.020	0.028
b	0.25	0.35	0.010	0.014
C	0.07	0.20	0.0028	0.0079
D	1.10	1.30	0.043	0.051
E	0.70	0.90	0.028	0.035
HE	1.50	1.70	0.059	0.067
L	0.15	0.25	0.006	0.010

**Marking**



**Ordering information**

Order code	Package	Base qty	Delivery mode
UMW AZ5125-01H	SOD-523	3000	Tape and reel

单击下面可查看定价，库存，交付和生命周期等信息

[>>UMW\(友台半导体\)](#)