

Features

- High Efficiency Components in a Dual SOP-8 Package
- High Density Power MOSFET with Low $R_{DS(on)}$
- Miniature SOP-8 Surface Mount Package – Saves Board Space
- Diode Exhibits High Speed with Soft Recovery
- I_{DSS} Specified at Elevated Temperature
- Avalanche Energy Specified

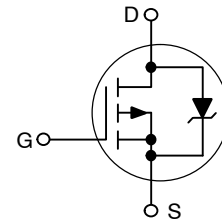

Applications

- DC-DC Converters
- Low Voltage Motor Control
- Power Management in Portable and Battery-Powered Products, i.e.: Computers, Printers, PCMCIA Cards, Cellular & Cordless Telephones
- $V_{DS(V)} = -30V$
- $R_{DS(ON)} < 85m\Omega$ ($V_{GS} = -10V$)
- $R_{DS(ON)} < 125m\Omega$ ($V_{GS} = -4.5V$)

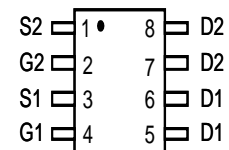

MAXIMUM RATINGS ($T_J = 25^\circ C$ unless otherwise noted)

Rating	Symbol	Value	Unit
Drain-to-Source Voltage	V_{DSS}	-30	V
Gate-to-Source Voltage – Continuous	V_{GS}	± 20	V
Thermal Resistance –			
Junction-to-Ambient (Note 1)	$R_{\theta JA}$	171	$^\circ C/W$
Total Power Dissipation @ $T_A = 25^\circ C$	P_D	0.73	W
Continuous Drain Current @ $25^\circ C$	I_D	-2.34	A
Continuous Drain Current @ $70^\circ C$	I_D	-1.87	A
Pulsed Drain Current (Note 4)	I_{DM}	-8.0	A
Thermal Resistance –			
Junction-to-Ambient (Note 2)	$R_{\theta JA}$	100	$^\circ C/W$
Total Power Dissipation @ $T_A = 25^\circ C$	P_D	1.25	W
Continuous Drain Current @ $25^\circ C$	I_D	-3.05	A
Continuous Drain Current @ $70^\circ C$	I_D	-2.44	A
Pulsed Drain Current (Note 4)	I_{DM}	-12	A
Thermal Resistance –			
Junction-to-Ambient (Note 3)	$R_{\theta JA}$	62.5	$^\circ C/W$
Total Power Dissipation @ $T_A = 25^\circ C$	P_D	2.0	W
Continuous Drain Current @ $25^\circ C$	I_D	-3.86	A
Continuous Drain Current @ $70^\circ C$	I_D	-3.1	A
Pulsed Drain Current (Note 4)	I_{DM}	-15	A
Operating and Storage Temperature Range	T_J, T_{stg}	-55 to +150	$^\circ C$
Single Pulse Drain-to-Source Avalanche Energy – Starting $T_J = 25^\circ C$ ($V_{DD} = -30$ Vdc, $V_{GS} = -4.5$ Vdc, Peak $I_L = -7.5$ Apk, $L = 5$ mH, $R_G = 25 \Omega$)	E_{AS}	140	mJ
Maximum Lead Temperature for Soldering Purposes, 1/8" from case for 10 seconds	T_L	260	$^\circ C$

ELECTRICAL CHARACTERISTICS ($T_J = 25^\circ\text{C}$ unless otherwise noted) (Note 5)

Characteristic	Symbol	Min	Typ	Max	Unit
Drain-to-Source Breakdown Voltage ($V_{GS} = 0\text{ Vdc}$, $I_D = -250\ \mu\text{Adc}$) Temperature Coefficient (Positive)	$V_{(BR)DSS}$	-30	-30		Vdc mV/°C
Zero Gate Voltage Drain Current ($V_{DS} = -24\text{ Vdc}$, $V_{GS} = 0\text{ Vdc}$, $T_J = 25^\circ\text{C}$) ($V_{DS} = -24\text{ Vdc}$, $V_{GS} = 0\text{ Vdc}$, $T_J = 125^\circ\text{C}$) ($V_{DS} = -30\text{ Vdc}$, $V_{GS} = 0\text{ Vdc}$, $T_J = 25^\circ\text{C}$)	I_{DSS}			-1.0 -20 -2.0	μAdc
Gate-Body Leakage Current ($V_{GS} = -20\text{ Vdc}$, $V_{DS} = 0\text{ Vdc}$)	I_{GSS}			-100	nAdc
Gate-Body Leakage Current ($V_{GS} = +20\text{ Vdc}$, $V_{DS} = 0\text{ Vdc}$)	I_{GSS}			100	nAdc
Gate Threshold Voltage ($V_{DS} = V_{GS}$, $I_D = -250\ \mu\text{Adc}$) Temperature Coefficient (Negative)	$V_{GS(th)}$	-1.0	-1.7 3.6	-2.5	Vdc
Static Drain-to-Source On-State Resistance ($V_{GS} = -10\text{ Vdc}$, $I_D = -3.05\text{ Adc}$) ($V_{GS} = -4.5\text{ Vdc}$, $I_D = -1.5\text{ Adc}$)	$R_{DS(on)}$		0.063 0.090	0.085 0.125	Ω
Forward Transconductance ($V_{DS} = -15\text{ Vdc}$, $I_D = -3.05\text{ Adc}$)	g_{FS}		5.0		Mhos
Input Capacitance	$(V_{DS} = -24\text{ Vdc}$, $V_{GS} = 0\text{ Vdc}$, $f = 1.0\text{ MHz}$)	C_{iss}	520	750	pF
Output Capacitance		C_{oss}	170	325	
Reverse Transfer Capacitance		C_{rss}	70	135	
Turn-On Delay Time	$(V_{DD} = -24\text{ Vdc}$, $I_D = -3.05\text{ Adc}$, $V_{GS} = -10\text{ Vdc}$, $R_G = 6.0\ \Omega$)	$t_{d(on)}$	12	22	ns
Rise Time		t_r	16	30	
Turn-Off Delay Time		$t_{d(off)}$	45	80	
Fall Time		t_f	45	80	
Turn-On Delay Time	$(V_{DD} = -24\text{ Vdc}$, $I_D = -1.5\text{ Adc}$, $V_{GS} = -4.5\text{ Vdc}$, $R_G = 6.0\ \Omega$)	$t_{d(on)}$	16		ns
Rise Time		t_r	42		
Turn-Off Delay Time		$t_{d(off)}$	32		
Fall Time		t_f	35		
Total Gate Charge	$(V_{DS} = -24\text{ Vdc}$, $V_{GS} = -10\text{ Vdc}$, $I_D = -3.05\text{ Adc}$)	Q_{tot}	16	25	nC
Gate-Source Charge		Q_{gs}	2.0		
Gate-Drain Charge		Q_{gd}	4.5		
Diode Forward On-Voltage ($I_S = -3.05\text{ Adc}$, $V_{GS} = 0\text{ V}$) ($I_S = -3.05\text{ Adc}$, $V_{GS} = 0\text{ V}$, $T_J = 125^\circ\text{C}$)	V_{SD}		-0.96 -0.78	-1.25	Vdc
Reverse Recovery Time	$(I_S = -3.05\text{ Adc}$, $V_{GS} = 0\text{ Vdc}$, $di_S/dt = 100\text{ A}/\mu\text{s}$)	t_{rr}	34		ns
		t_a	18		
		t_b	16		
Reverse Recovery Stored Charge	Q_{RR}		0.03		μC

- Handling precautions to protect against electrostatic discharge is mandatory.
- Indicates Pulse Test: Pulse Width = 300 μs max, Duty Cycle = 2%.
- Switching characteristics are independent of operating junction temperature.

TYPICAL ELECTRICAL CHARACTERISTICS

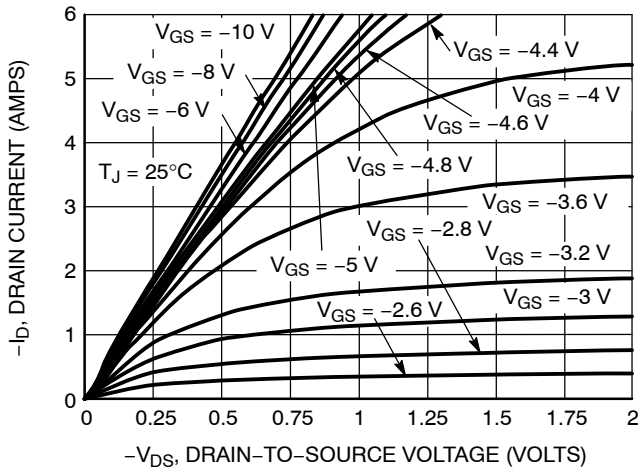

Figure 1. On-Region Characteristics

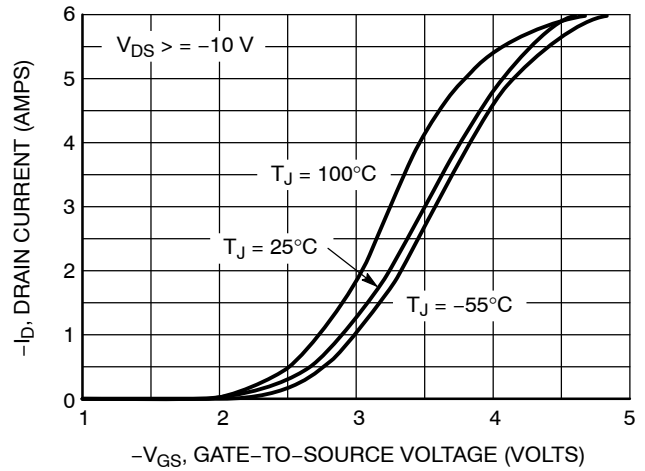

Figure 2. Transfer Characteristics

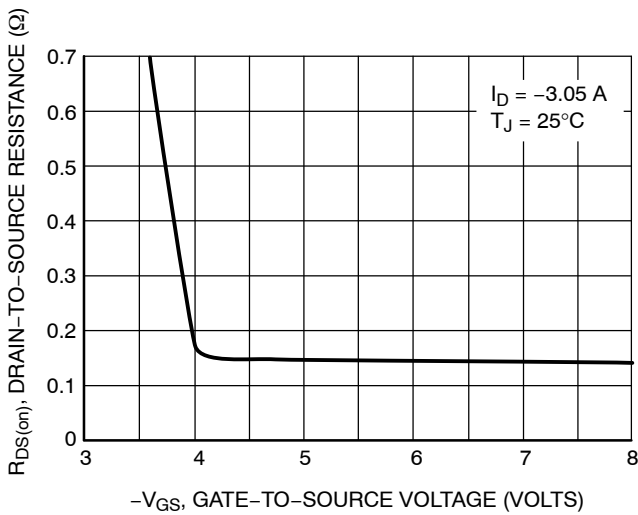

Figure 3. On-Resistance vs. Gate-to-Source Voltage

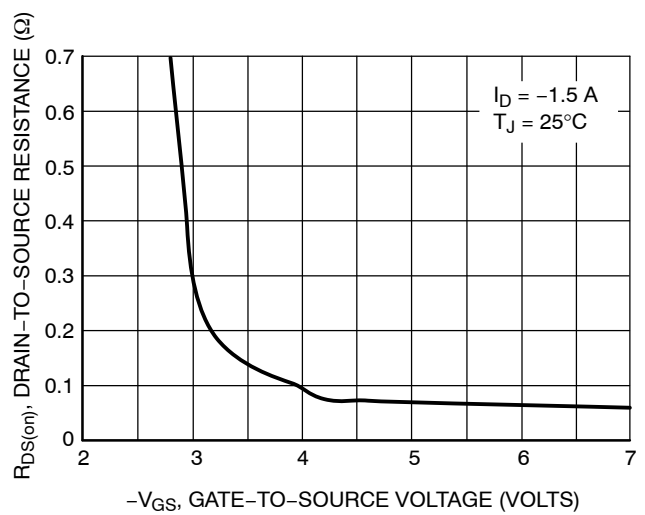

Figure 4. On-Resistance vs. Gate-to-Source Voltage

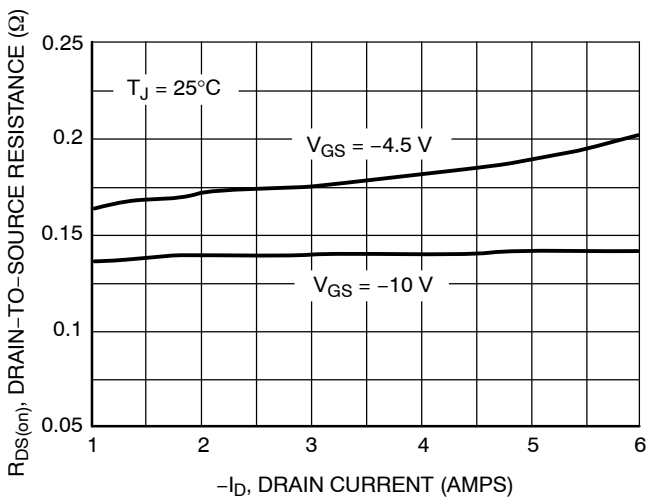

Figure 5. On-Resistance vs. Drain Current and Gate Voltage

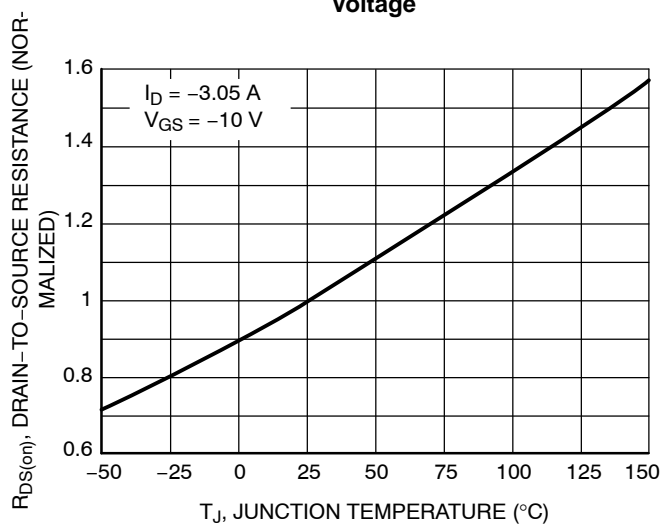

Figure 6. On Resistance Variation with Temperature

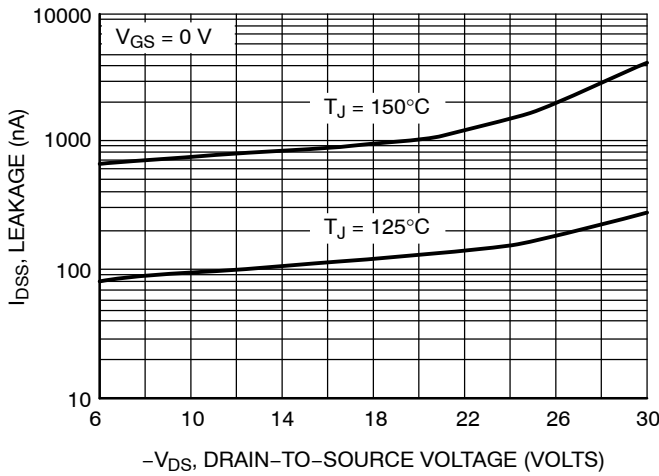

Figure 7. Drain-to-Source Leakage Current vs. Voltage

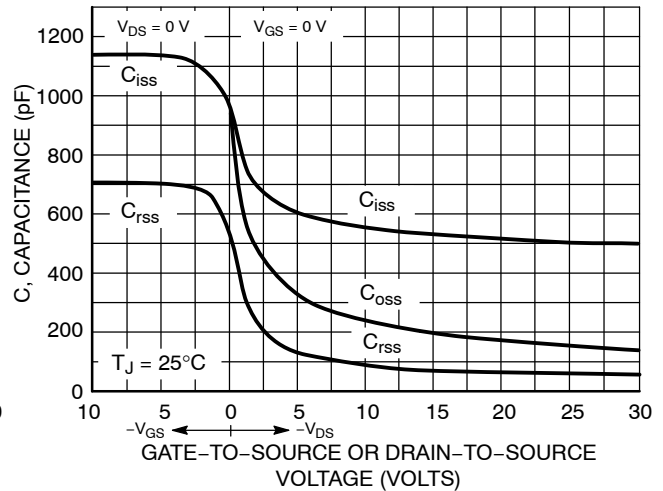

Figure 8. Capacitance Variation

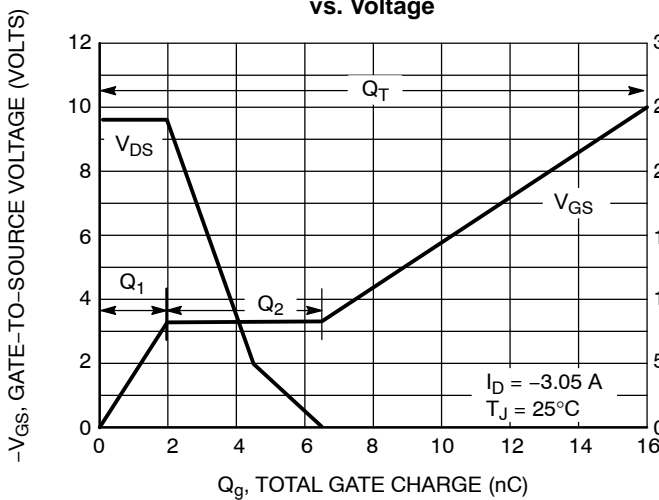

Figure 9. Gate-to-Source and Drain-to-Source Voltage vs. Total Charge

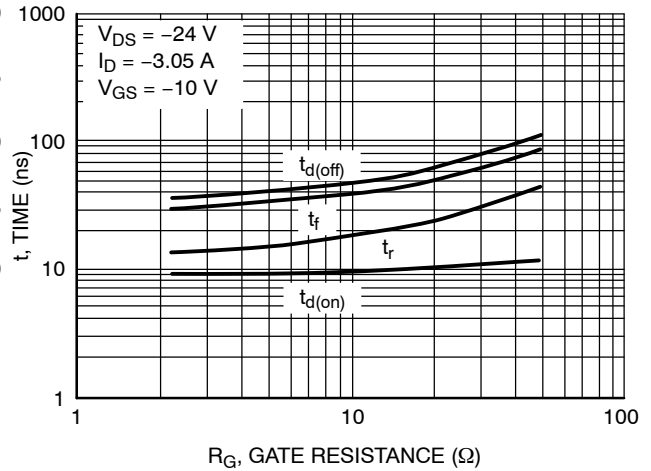

Figure 10. Resistive Switching Time Variation vs. Gate Resistance

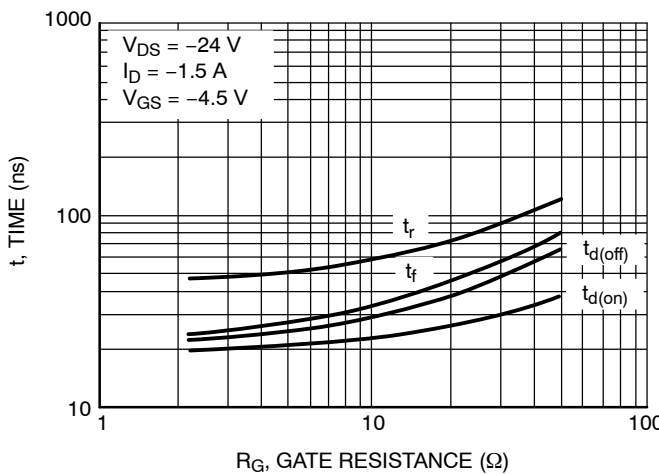

Figure 11. Resistive Switching Time Variation vs. Gate Resistance

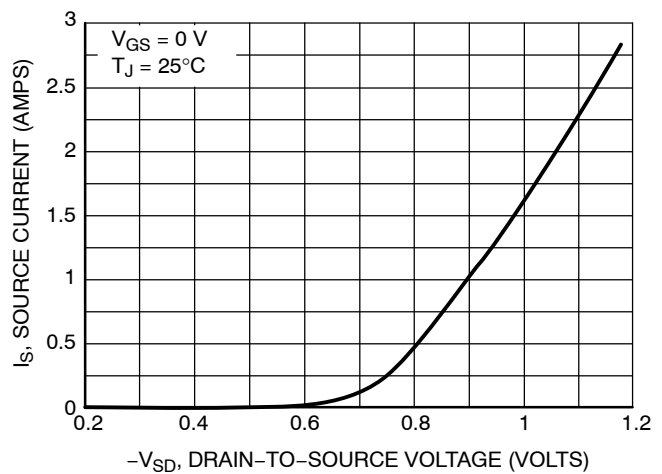

Figure 12. Diode Forward Voltage vs. Current

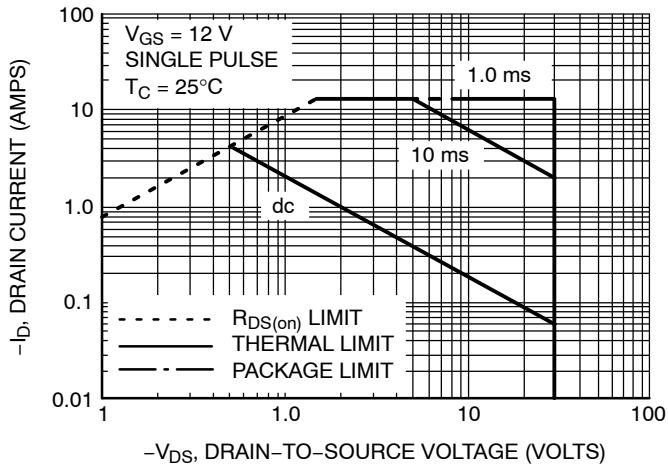

Figure 13. Maximum Rated Forward Biased Safe Operating Area

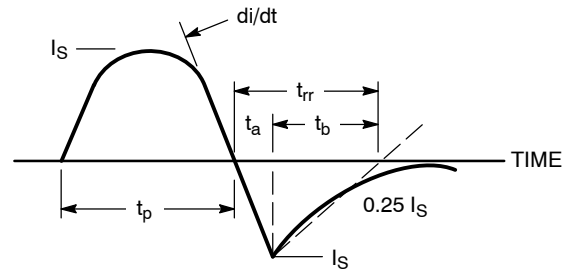

Figure 14. Diode Reverse Recovery Waveform

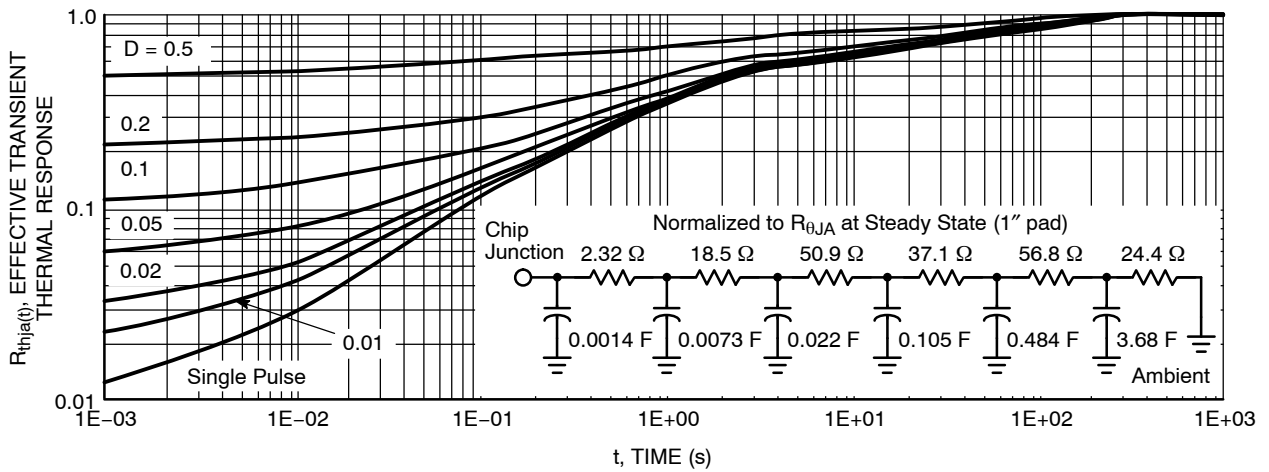
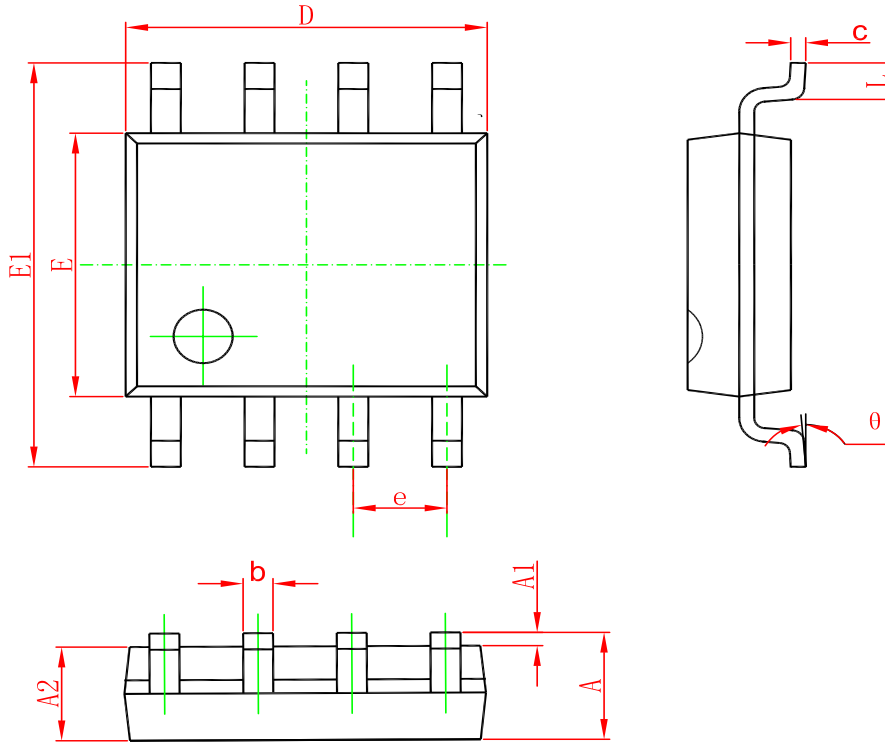

Figure 15. FET Thermal Response

PACKAGE OUTLINE DIMENSIONS

SOP-8



Symbol	Dimensions In Millimeters		Dimensions In Inches	
	Min	Max	Min	Max
A	1.350	1.750	0.053	0.069
A1	0.100	0.250	0.004	0.010
A2	1.350	1.550	0.053	0.061
b	0.330	0.510	0.013	0.020
c	0.170	0.250	0.006	0.010
D	4.700	5.100	0.185	0.200
E	3.800	4.000	0.150	0.157
E1	5.800	6.200	0.228	0.244
e	1.270(BSC)		0.050(BSC)	
L	0.400	1.270	0.016	0.050
θ	0°	8°	0°	8°

Marking

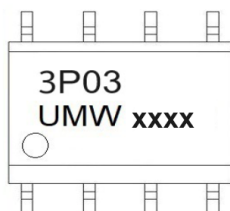

Ordering information

Order code	Package	Baseqty	Deliverymode
UMW NTMD3P03R2G	SOP-8	3000	Tape and reel

单击下面可查看定价，库存，交付和生命周期等信息

[>>UMW\(友台半导体\)](#)