

General Description

The AOZ8905 is a transient voltage suppressor array designed to protect high speed data lines such as HDMI, USB 2.0, MDDI, SATA, and Gigabit Ethernet from damaging ESD events. This device incorporates eight surge rated, low capacitance steering diodes and a TVS in a single package. During transient conditions, the steering diodes direct the transient to either the positive side of the power supply line or to ground. The AOZ8905 provides a typical line to line capacitance of 0.35pF and low insertion loss up to 3GHz providing greater signal integrity

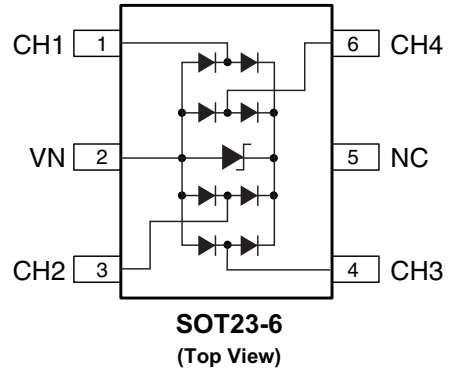

Features

- ESD protection for high-speed data lines:
 - IEC 61000-4-2, level 4 (ESD) immunity test
 - ±15kV (air discharge) and ±8kV (contact discharge)
 - IEC61000-4-4 (EFT) 40A (5/50nS)
 - IEC61000-4-5 (Lightning) 2.5A (8/20µS)
 - Human Body Model (HBM) ±15kV
- Array of surge rated diodes with internal TVS diode
- Protects four I/O lines
- Low capacitance between I/O lines: 0.35pF
- Low clamping voltage
- Low operating voltage: 5.0V

Applications

- HDMI, USB 2.0, MDDI, SATA ports
- Monitors and flat panel displays
- Set-top box
- Video graphics cards
- Digital Video Interface (DVI)
- Notebook computers

Absolute Maximum Ratings

Exceeding the Absolute Maximum ratings may damage the device.

Parameter	Rating
Storage Temperature (T_S)	-65°C to +150°C
ESD Rating per IEC61000-4-2, contact ⁽¹⁾	±8kV
ESD Rating per IEC61000-4-2, air ⁽¹⁾	±15kV
ESD Rating per Human Body Model ⁽²⁾	±15kV

Notes:

- IEC 61000-4-2 discharge with $C_{Discharge} = 150\text{pF}$, $R_{Discharge} = 330\Omega$.
- Human Body Discharge per MIL-STD-883, Method 3015 $C_{Discharge} = 100\text{pF}$, $R_{Discharge} = 1.5\text{k}\Omega$.

Maximum Operating Ratings

Parameter	Rating
Junction Temperature (T_J)	-40°C to +125°C

Electrical Characteristics

$T_A = 25^\circ\text{C}$ unless otherwise specified. Specifications in **BOLD** indicate a temperature range of -40°C to +85°C.

Symbol	Parameter	Conditions	Min.	Typ.	Max.	Units
V_{RWM}	Reverse Working Voltage	Between I/O and VN ⁽³⁾			5.0	V
V_{BR}	Reverse Breakdown Voltage	$I_T = 1\text{mA}$, between I/O and VN ⁽⁴⁾	6.0			V
I_R	Reverse Leakage Current	$V_{RWM} = 5\text{V}$, between I/O and VN			1	μA
V_F	Diode Forward Voltage	$I_F = 15\text{mA}$	0.70	0.85	1	V
V_{CL}	Channel Clamp Voltage Positive Transients Negative Transient	$I_{PP} = 1\text{A}$, $t_p = 100\text{ns}$, any I/O pin to Ground ⁽⁵⁾			15.0 -3.5	V V
	Channel Clamp Voltage Positive Transients Negative Transient	$I_{PP} = 5\text{A}$, $t_p = 100\text{ns}$, any I/O pin to Ground ⁽⁵⁾			22.0 -6.0	V V
	Channel Clamp Voltage Any I/O Pin to Ground	$I_{PP} = 1\text{A}$, $t_p = 8/20\mu\text{s}$			15.5	V
C_j	Channel Input Capacitance	$V_R = 0\text{V}$, $f = 1\text{MHz}$, between I/O pins		0.35	0.40	pF
		$V_R = 0\text{V}$, $f = 1\text{MHz}$, any I/O pin to Ground		0.70	0.80	pF

Notes:

- The working peak reverse voltage, V_{RWM} , should be equal to or greater than the DC or continuous peak operating voltage level.
- V_{BR} is measured at the pulse test current I_T .
- Measurements performed using a 100ns Transmission Line Pulse (TLP) system.

Typical Performance Characteristics

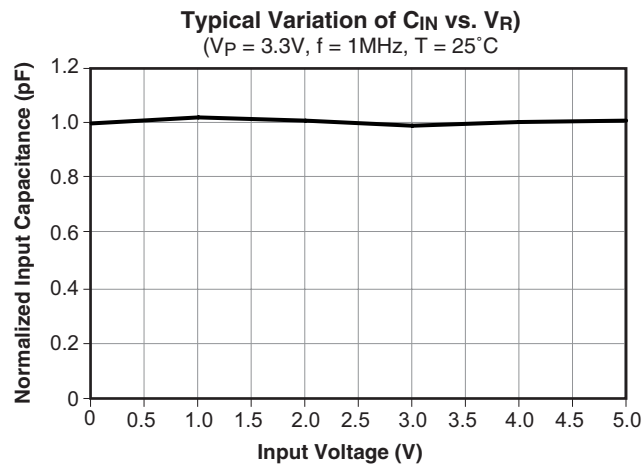
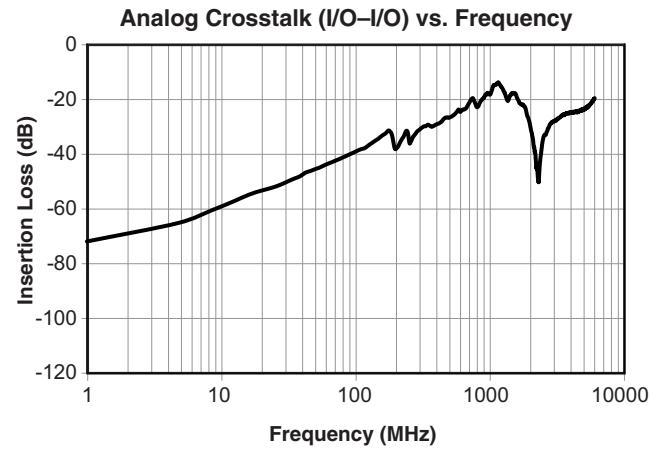
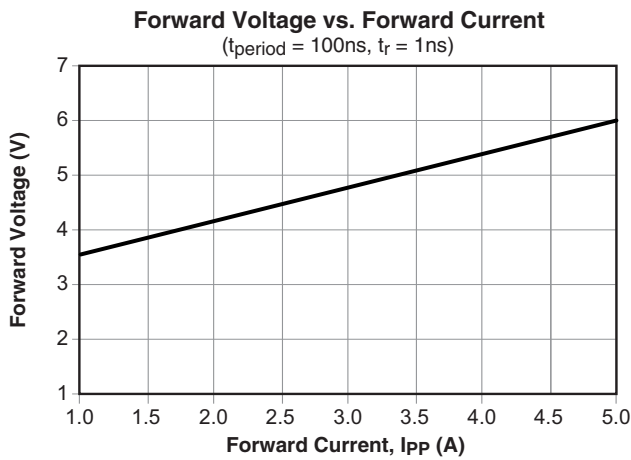
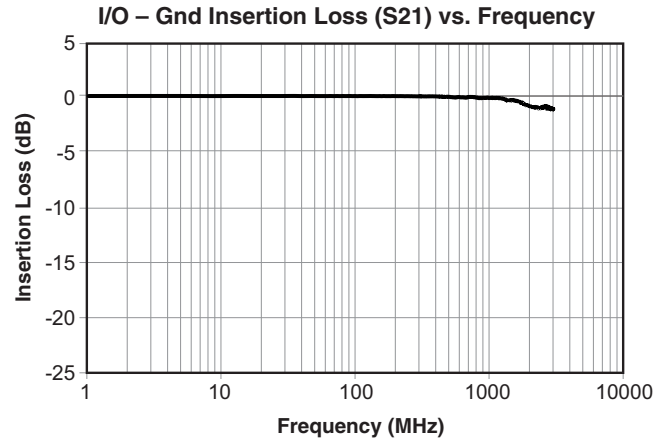
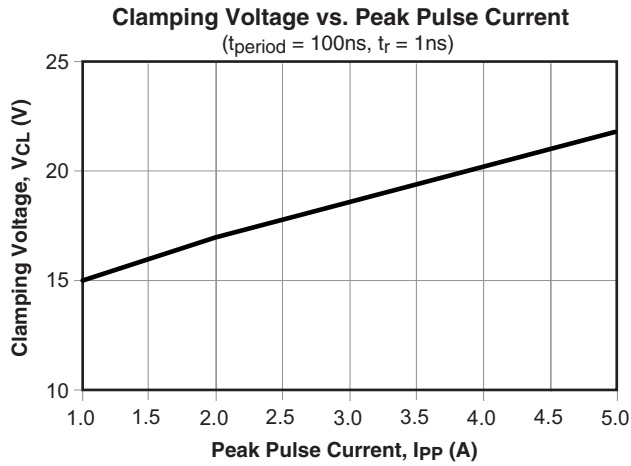

TDR for HDMI 1.3

The AOZ8905 TDR test results indicates the minimal effect the low capacitance has on the HDMI 1.3 TDR measurements. Below are the graphs from the TDR measurements. The two graphs show the before and

after results of the TDR of each of the differential data line (Clock, D0, D1, D2) of the HDMI when the AOZ8905 was populated onto the PCB.

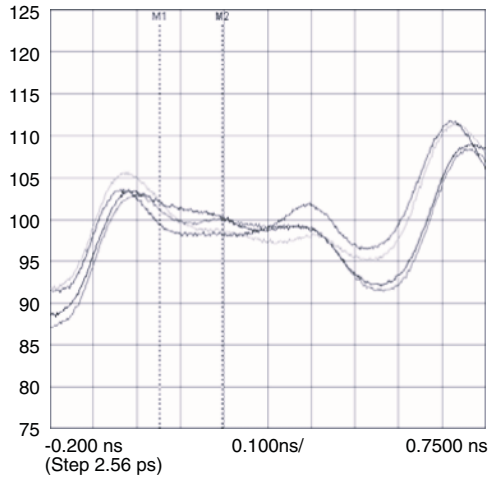

Figure 2. Ideal Stripe-Line
(TDR Measurement with 200pS Rise Time Using AOS Evaluation Board)

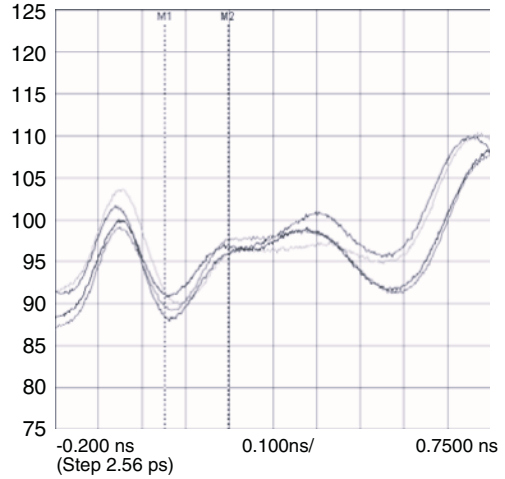
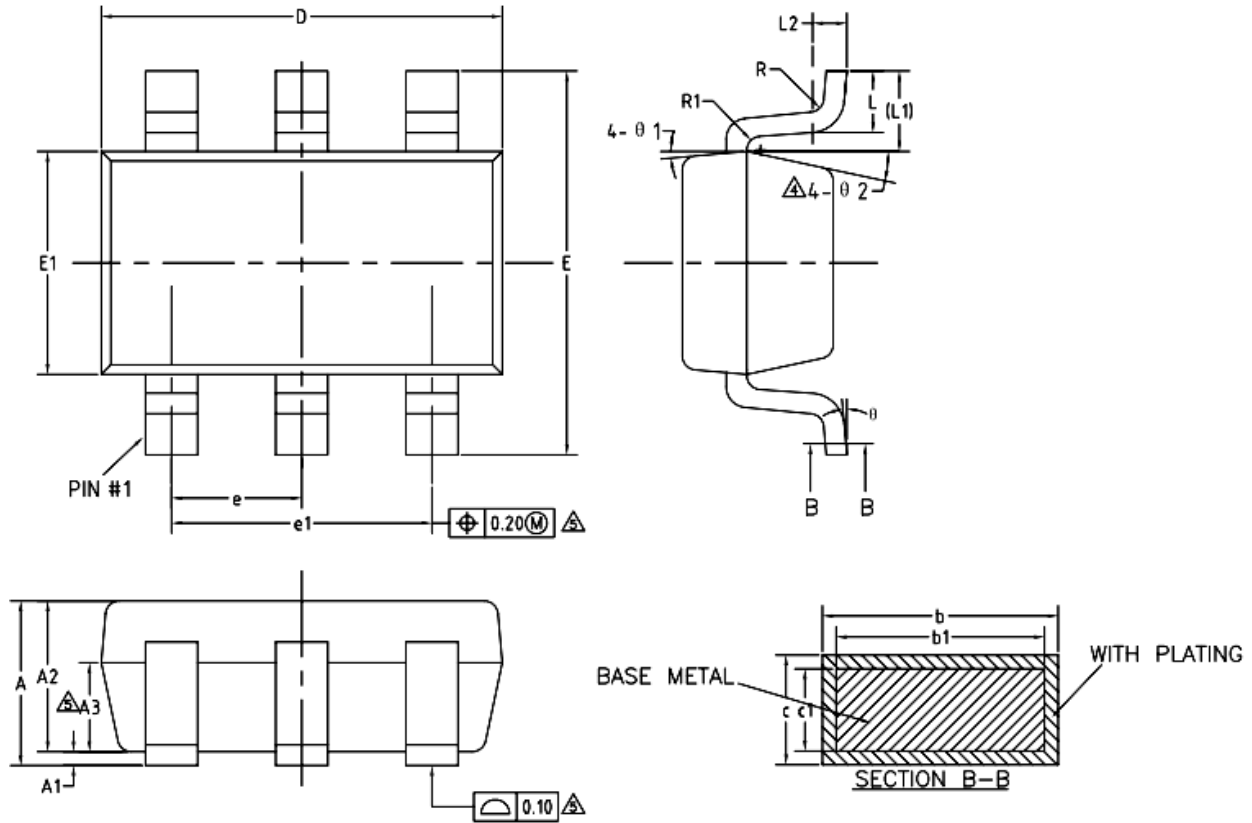

Figure 3. With AOZ8905 Device on the Board

SOT23-6



COMMON DIMENSIONS
(UNITS OF MEASURE=MILLIMETER)

SYMBOL	MIN	NOM	MAX
A	—	—	1.25
A1	0	—	0.15
A2	1.00	1.10	1.20
A3	0.60	0.65	0.70
b	0.36	—	0.50
b1	0.36	0.38	0.45
c	0.14	—	0.20
c1	0.14	0.15	0.16
D	2.826	2.926	3.026
E	2.60	2.80	3.00
E1	1.526	1.626	1.726
Δ e	0.90	0.95	1.00
Δ e1	1.80	1.90	2.00
L	0.35	0.45	0.60
L1	0.59REF		
L2	0.25BSC		
Δ R	0.10	—	—
Δ R1	0.10	—	0.20
θ	0°	—	8°
$\theta 1$	3°	5°	7°
Δ $\theta 2$	6°	—	14°

Marking

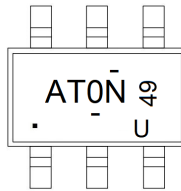

Ordering information

Order code	Package	Base qty	Delivery mode
UMW AOZ8905CI	SOT23-6	3000	Tape and reel

单击下面可查看定价，库存，交付和生命周期等信息

[>>UMW\(友台半导体\)](#)