

DESCRIPTION

This monolithic integrated circuit is an adjustable 3-terminal positive voltage regulator designed to supply more than 1.5A of load current with an output voltage adjustable over a 1.2 to 37V. It employs internal current limiting, thermal shut-down and safe area compensation.

FEATURE

- Internal thermal overload protection
- Internal short circuit current limiting
- Output transistor safe operating area compensation

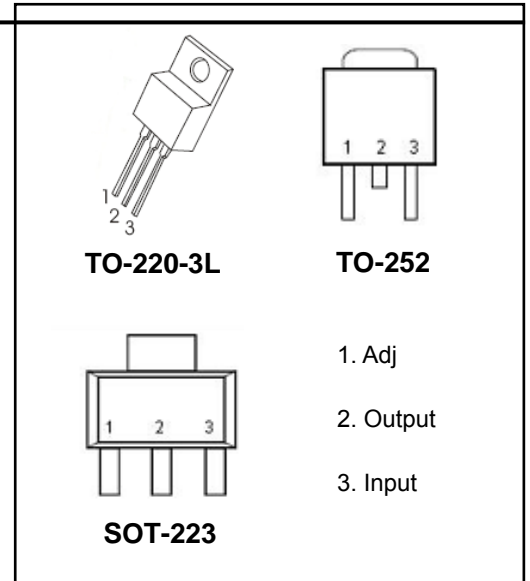

Internal Block Diagram

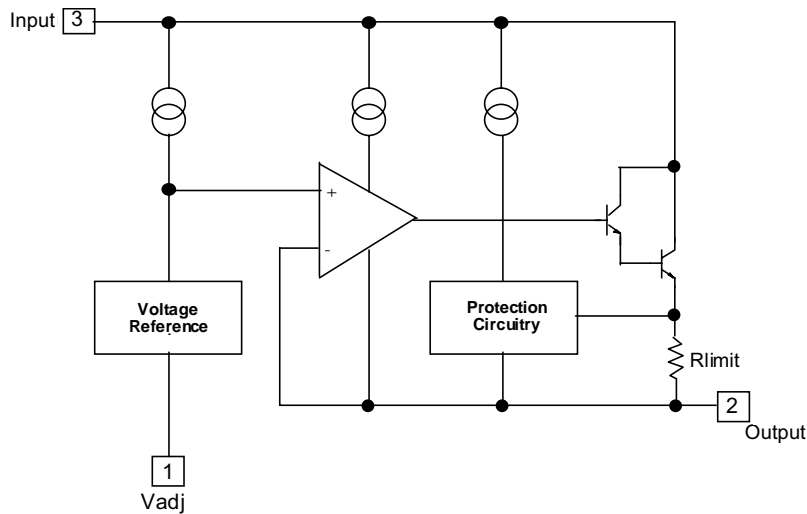

Absolute Maximum Ratings

Symbol	Parameter	Value	Unit
V_I-V_O	Input-Output Voltage Differential	40	V
T_{LEAD}	Lead Temperature	230	°C
P_D	Power Dissipation	Internally limited	W
T_J	Operating Junction Temperature Range	0~125	°C
T_{stg}	Storage Temperature Range	-55~125	
$\Delta V_O / \Delta T$	Temperature Coefficient of Output Voltage	±0.02	%/°C

ELECTRICAL CHARACTERISTICS

($V_O-V_I=5V, I_O=0.5A, 0^\circ C \leq T_J \leq +125^\circ C, I_{MAX}=1.5A, P_{DMAX}=20W$, unless otherwise specified)

Parameter	Symbol	Test conditions	MIN	TYP	MAX	UNIT
Line Regulation(note1)	R_{line}	$T_A=25^\circ C$ $3V \leq V_I-V_O \leq 40V$		0.01	0.04	%V
		$3V \leq V_I-V_O \leq 40V$		0.02	0.07	
Load Regulation(note1)	R_{load}	$T_A=25^\circ C, 10mA \leq I_O \leq I_{MAX}$ $V_O < 5V$ $V_O \geq 5V$		18 0.4	25 0.5	mV
		$10mA \leq I_O \leq I_{MAX}$ $V_O < 5V$ $V_O \geq 5V$		40 0.8	70 1.5	% V_O
Adjustable Pin Current	I_{ADJ}	-		46	100	μA
Adjustable Pin Current Change	ΔI_{ADJ}	$3V \leq V_I-V_O \leq 40V$ $10mA \leq I_O \leq I_{MAX}, P_D \leq P_{MAX}$		2.0	5	
Reference Voltage	V_{REF}	$3V \leq V_{IN}-V_O \leq 40V$ $10mA \leq I_O \leq I_{MAX}, P_D \leq P_{MAX}$	1.20	1.25	1.30	V
Temperature Stability	ST_T	-		0.7		%/ V_O
Minimum Load Current to Maintain Regulation	$I_{L(MIN)}$	$V_I-V_O=40V$		3.5	12	mA
Maximum Output Current	$I_{O(MAX)}$	$V_I-V_O \leq 15V, P_D \leq P_{MAX}$ $V_I-V_O \leq 40V, P_D \leq P_{MAX}$ $T_A=25^\circ C$	1.0	2.2 0.3		A
RMS Noise, % of V_{OUT}	e_N	$T_A=25^\circ C, 10Hz \leq f \leq 10KHz$		0.003	0.01	%/ V_O
Ripple Rejection	RR	$V_O=10V, f=120Hz$ without C_{ADJ} $C_{ADJ}=10\mu F$ (note2)	66	60 75		dB
Long-Term Stability, $T_J=T_{HIGH}$	ST	$T_A=25^\circ C$ for end point measurements, 1000HR		0.3	1	%
Thermal Resistance Junction to case	$R_{\theta JC}$	-		5		°C/W

Notes:

1. Load and line regulation are specified at constant junction temperature. Change in V_D due to heating effects must be taken into account separately. Pulse testing with low duty is used. ($P_{MAX}=20W$)
2. C_{ADJ} . when used, is connected between the adjustment pin and ground.

Typical Application

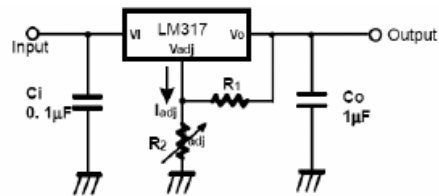

$$V_O = 1.25V (1 + R_2 / R_1) + I_{adj} R_2$$

C_i is required when regulator is located an appreciable distance from power supply filter.

C_o is not needed for stability, however, it does improve transient response.

Since I_{ADJ} is controlled to less than $100\mu A$, the error associated with this term is negligible in most applications.

■ TO-220-3L封装外形图

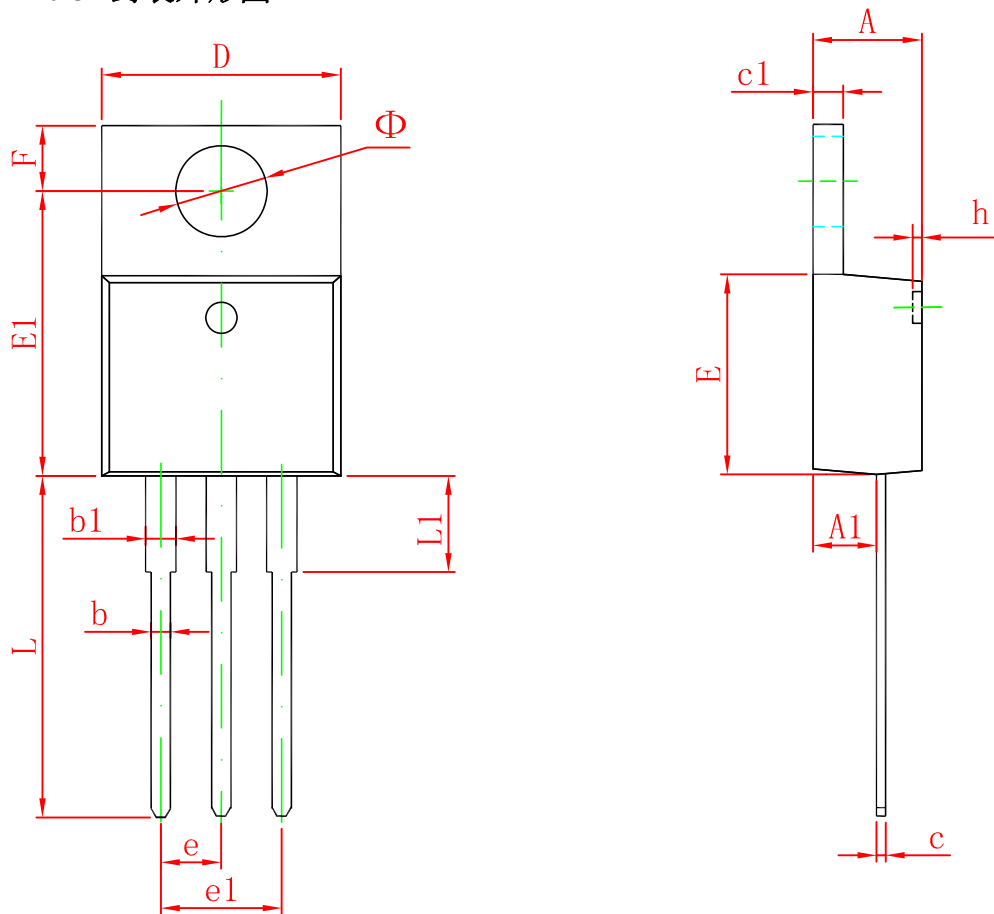

Symbol	Dimensions In Millimeters		Dimensions In Inches	
	Min	Max	Min	Max
A	4.470	4.670	0.176	0.184
A1	2.520	2.820	0.099	0.111
b	0.710	0.910	0.028	0.036
b1	1.170	1.370	0.046	0.054
c	0.310	0.530	0.012	0.021
c1	1.170	1.370	0.046	0.054
D	10.010	10.310	0.394	0.406
E	8.500	8.900	0.335	0.350
E1	12.060	12.460	0.475	0.491
e	2.540 TYP		0.100 TYP	
e1	4.980	5.180	0.196	0.204
F	2.590	2.890	0.102	0.114
h	0.000	0.300	0.000	0.012
L	13.400	13.800	0.528	0.543
L1	3.560	3.960	0.140	0.156
Φ	3.735	3.935	0.147	0.155

■ SOT223 封装外形图

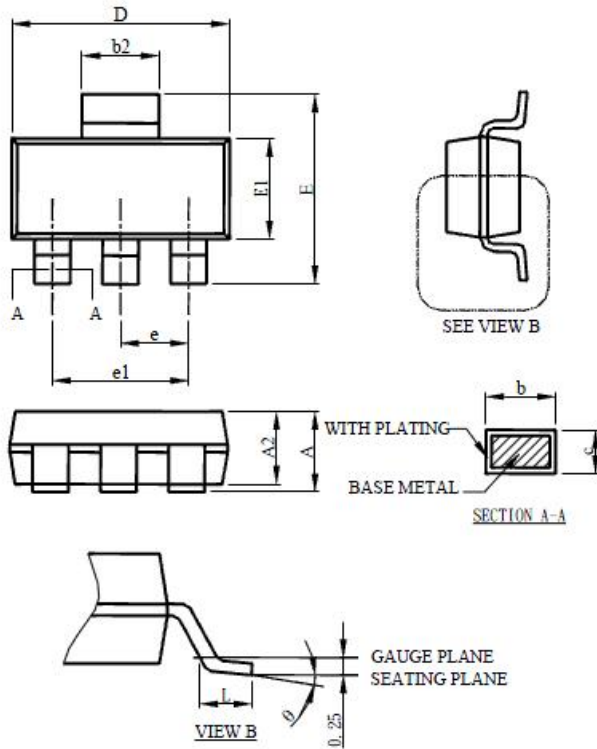

SOT-223		
SYMBOL	MILLIMETERS	
	MIN.	MAX.
A		1.80
A1	0.02	0.10
A2	1.55	1.65
b	0.66	0.84
b2	2.90	3.10
c	0.23	0.33
D	6.30	6.70
E	6.70	7.30
E1	3.30	3.70
e	2.30 BSC	
e1	4.60 BSC	
L	0.90	
θ	0°	8°

- Note:
1. Refer to JEDEC TO-261AA.
 2. Dimension D and E1 are determined at the outermost extremes of the plastic body exclusive of mold flash, tie bar burrs, gate burrs, and interlead flash, but including any mismatch between the top and bottom of the plastic body.
 3. Controlling dimension is millimeter, converted inch dimensions are not necessarily exact.

■ TO-252 封裝外形圖

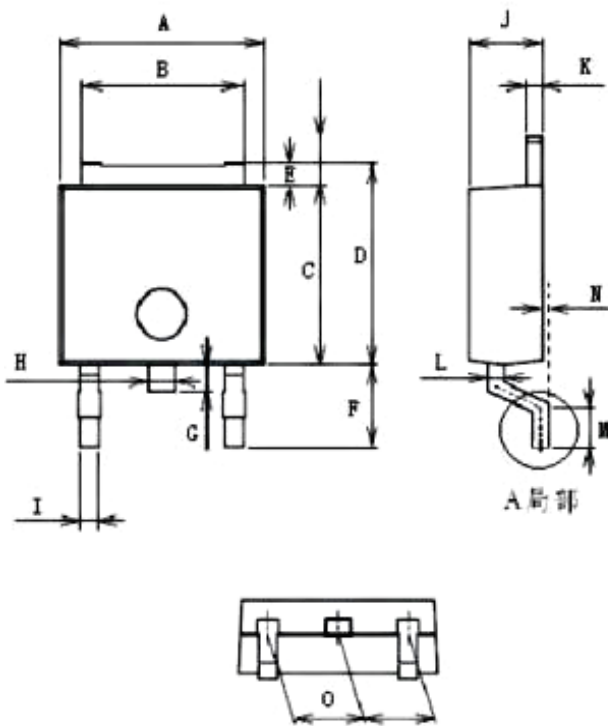

Unit: mm

Item	Min	Max
A	6.40	6.70
B	5.20	5.40
C	6.00	6.30
D	6.55	6.85
E	0.45	0.60
F	3.07	3.35
G	0.85	1.05
H	0.75	0.95
I	0.55	0.75
J	2.20	2.40
K	0.43	0.58
L	0.43	0.58
M	0.90	1.10
N	0.90	1.10
O	2.20	2.40

聲明:

- 我公司保留說明書更改權利，恕不另行通知；
- 任何半導體產品特性條件下都有一定失效或者發生故障的可能，買方有責任在使用我司產品進行系統設計和整機製造時遵守安全標準并採取安全措施，以避免潛在失敗風險可能造成人身傷害或財產損失情況的發生；
- 產品提升永無止境，我司將竭誠為客戶提供更優秀的半導體產品。

单击下面可查看定价，库存，交付和生命周期等信息

[>>UMW\(友台半导体\)](#)