

DESCRIPTIONS

The 099-04AT1G is a 4-channel ultra low capacitance rail clamp ESD protection diodes array. Each channel consists of a pair of ESD diodes that steer positive or negative ESD current to either the positive or negative rail. A zener diode is integrated in to the array between the positive and negative supply rails. In the typical applications, the negative rail pin (assigned as GND) is connected with system ground. The Positive ESD current is steered to the ground through an ESD diode and Zener diode and the positive ESD voltage is clamped to the zener voltage.

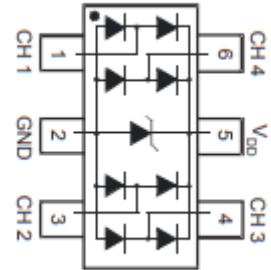

FEATURES

- 4 channels of ESD protection
- Provides ESD protection to IEC61000-4-2 level 4
 - $\pm 15\text{kV}$ air discharge
 - $\pm 8\text{kV}$ contact discharge
- Channel I/O to GND capacitance: 0.9pF(Max)
- Channel I/O to I/O capacitance: 0.45pF(Max)
- Low clamping voltage
- Low operating voltage
- Improved zener structure
- Optimized package for easy high speed data lines PCB layout

APPLICATIONS

- HDMI / DVI ports
- Display Port interface
- 10M / 100M / 1G Ethernet
- USB 2.0 interface
- VGA interface
- Flat panel Monitors / TVs;
- PC / Note book

ABSOLUTE MAXIMUM RATINGS

Characteristics	Symbol	Ratings	Unit
Peak Pulse Power(8/20μs)	P _{PP}	150	W
Peak Pulse Current(8/20μs)	I _{PP}	5	A
ESD per IEC 61000-4-2(Air)	V _{ESD1}	±15kV	kV
ESD per IEC 61000-4-2(Contact)	V _{ESD2}	±8kV	kV
Operating Temperature Range	T _{opr}	-55 ~ +125	°C
Storage Temperature Range	T _{stg}	-55 ~ +150	°C

ELECTRICAL CHARACTERISTICS (T_{amb}=25°C)

Characteristics	Symbol	Test Conditions	Min.	Typ.	Max.	Unit
Reverse Working Voltage	V _{RWM}	Any I/O pin to GND			5	V
Reverse Breakdown Voltage	V _{BR}	I _t =1mA; Any I/O pin to GND	6			V
Reverse Leakage Current	I _R	V _{RWM} =5V, T=25°C; Any I/O pin to GND			1	μA
Positive Clamping Voltage	V _{C1}	I _{PP} =1A, t _p =8/20 μs; Positive pulse; Any I/O pin to GND		8.5	12.0	V
Negative Clamping Voltage	V _{C2}	I _{PP} =1A, t _p =8/20 μs; Negative pulse; Any I/O pin to GND		1.8		V
Junction Capacitance Between Channel	C _{J1}	V _R =0V, f=1MHz; Between I/O pins		0.35	0.45	pF
Junction Capacitance Between I/O And GND	C _{J2}	V _R =0V, f=1MHz; Any I/O pin to GND			0.9	pF

TYPICAL ELECTRICAL CHARACTERISTICS CURVE

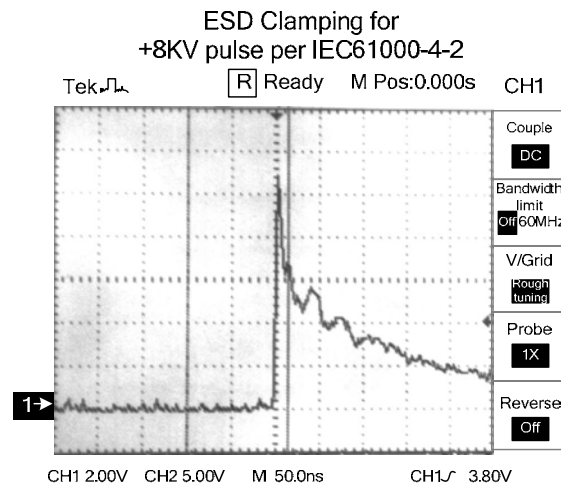
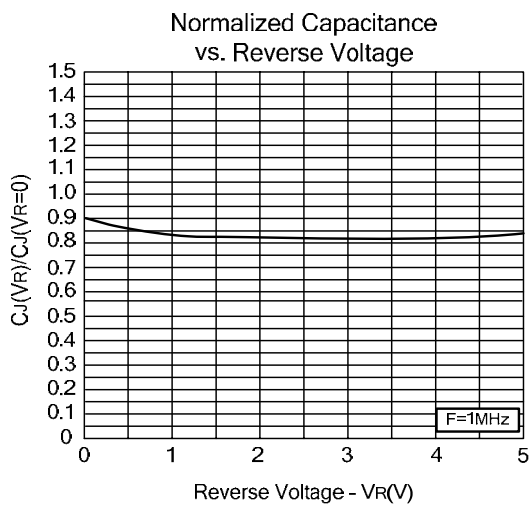
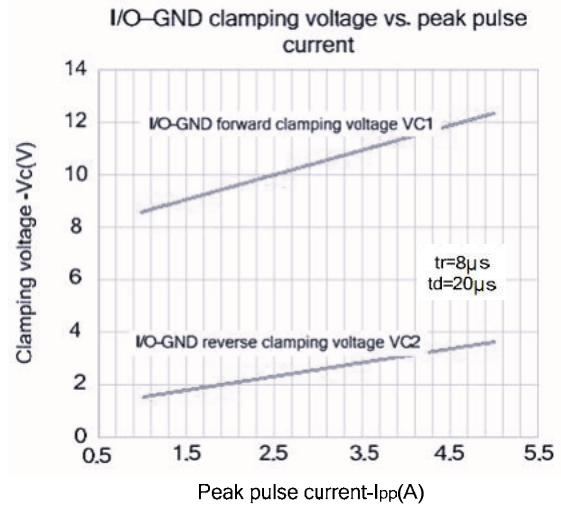
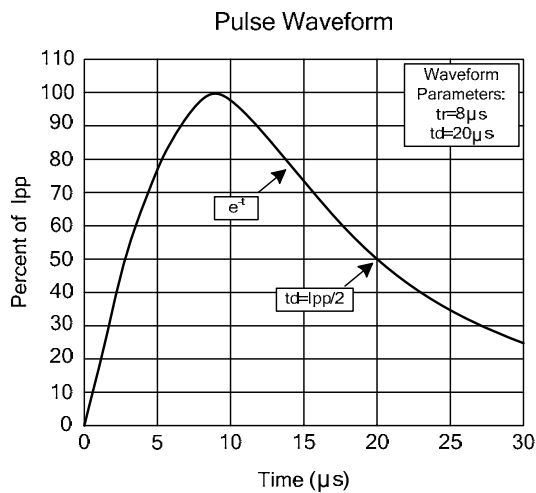
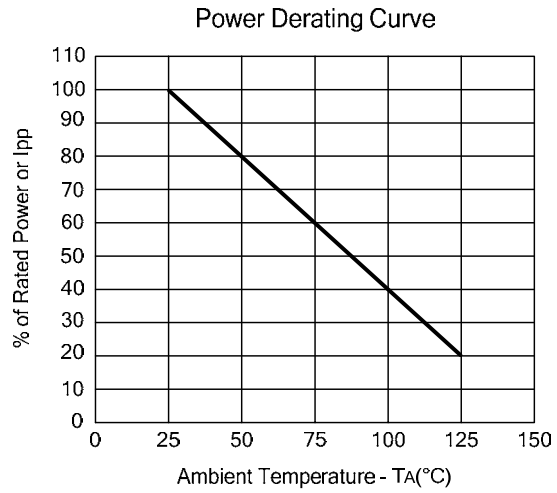
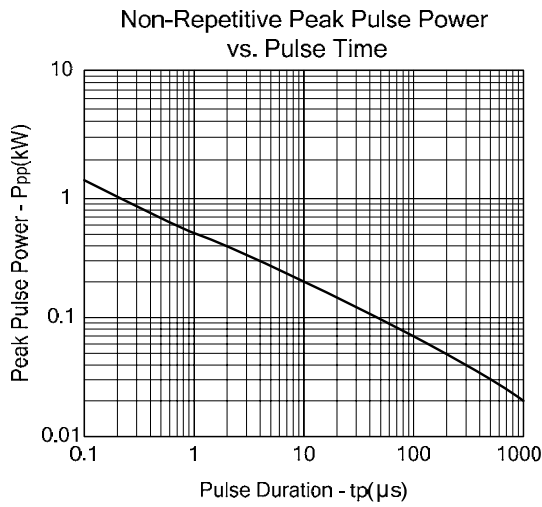

TYPICAL ELECTRICAL CHARACTERISTICS CURVE

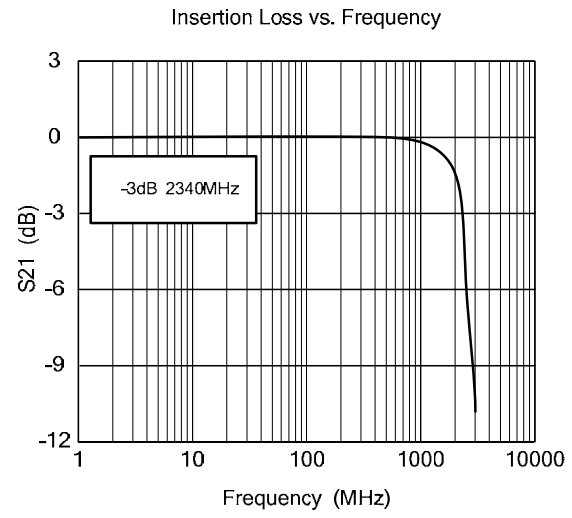
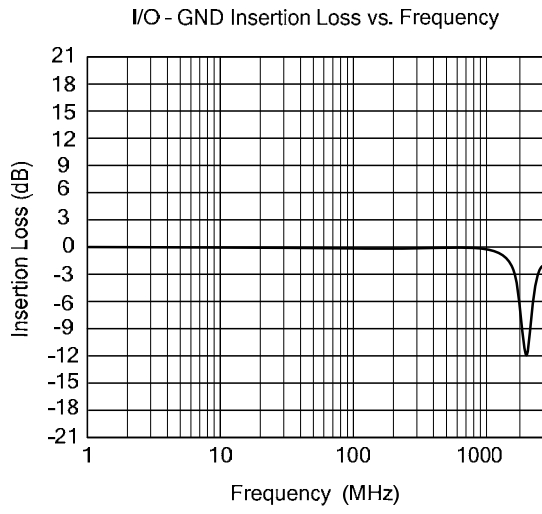

SOT23-6

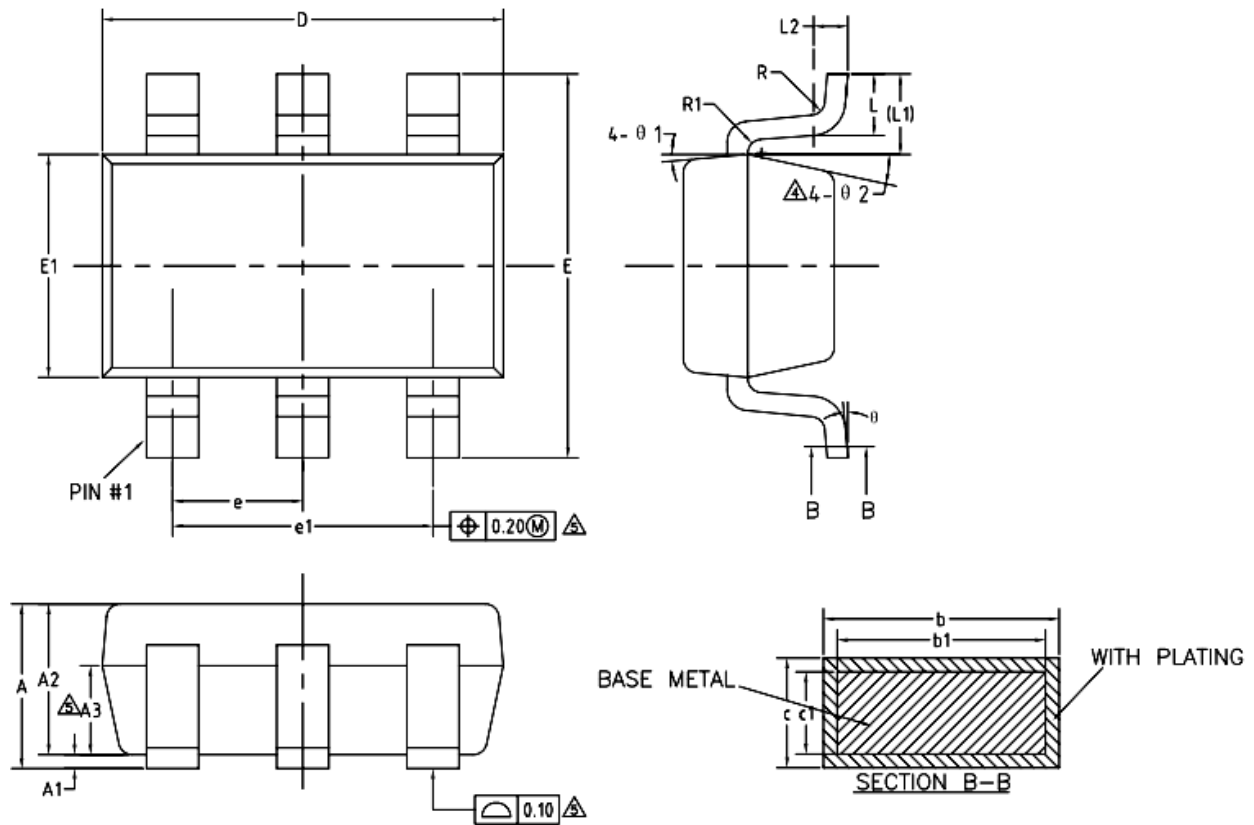

COMMON DIMENSIONS
(UNITS OF MEASURE=MILLIMETER)

SYMBOL	MIN	NOM	MAX
A	-	-	1.25
A1	0	-	0.15
A2	1.00	1.10	1.20
A3	0.60	0.65	0.70
b	0.36	-	0.50
b1	0.36	0.38	0.45
c	0.14	-	0.20
c1	0.14	0.15	0.16
D	2.826	2.926	3.026
E	2.60	2.80	3.00
E1	1.526	1.626	1.726
Δ e	0.90	0.95	1.00
Δ e1	1.80	1.90	2.00
L	0.35	0.45	0.60
L1	0.59REF		
L2	0.25BSC		
Δ R	0.10	-	-
Δ R1	0.10	-	0.20
θ	0°	-	8°
$\theta 1$	3°	5°	7°
Δ $\theta 2$	6°	-	14°

Marking

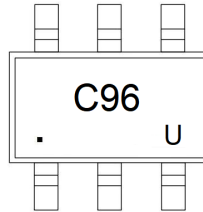

Ordering information

Order code	Package	Base qty	Delivery mode
UMW 099-04AT1G	SOT23-6	3000	Tape and reel

单击下面可查看定价，库存，交付和生命周期等信息

[>>UMW\(友台半导体\)](#)