



CD4069

CMOS IC

INVERTER CIRCUIT

DESCRIPTION

The UTC **CD4069** is a CMOS IC with six inverter circuits and designed for using of wide power supply operating range, low power consumption, high noise immunity, and symmetric controlled rise and fall times. The IC is capable of ESD protection by diode clamps to VDD and VSS.

FEATURES

- * Wide supply voltage range: 3.0V ~ 15V.
- * High noise immunity: 0.45 V_{DD} typ.
- * Low Power TTL compatibility: Fan out of 2 driving 74L or 1 driving 74LS.

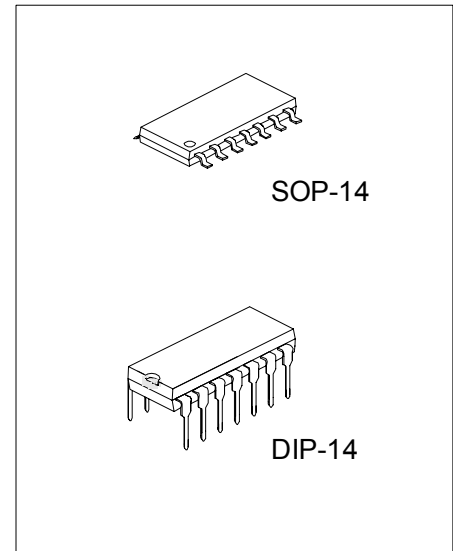

*Pb-free plating product number: CD4069L

ORDERING INFORMATION

Order Number		Package	Packing
Normal	Lead Free Plating		
CD4069-D14-T	CD4069L-D14-T	DIP-14	Tube
CD4069-S14-R	CD4069L-S14-R	SOP-14	Tape Reel
CD4069-S14-T	CD4069L-S14-T	SOP-14	Tube

<p>CD4069L-D14-T</p> <p>(1)Packing Type (2)Package Type (3)Lead Plating</p>	<p>(1) R: Tape Reel, T: Tube (2) D14: DIP-14, S14: SOP-14 (3) L: Lead Free Plating, Blank: Pb/Sn</p>
---	--

■ PIN CONFIGURATION

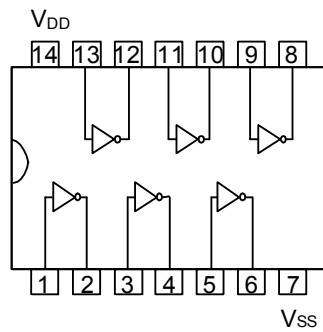

■ BLOCK DIAGRAM

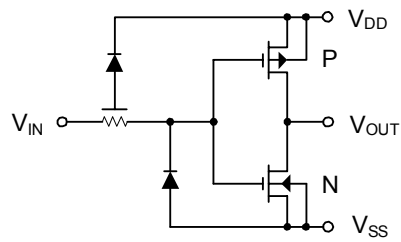

■ ABSOLUTE MAXIMUM RATINGS

PARAMETER	SYMBOL	RATINGS	UNIT
DC Supply Voltage	V_{DD}	-0.5 ~ +18	V
Input Voltage	V_{IN}	-0.5 ~ $V_{DD} + 0.5$	V
Storage Temperature Range	T_S	-65 ~ +150	
Power Dissipation	DIP-14	P_D	700
	SOP-14		500
Junction Temperature	T_J	125	
Operating Temperature	T_{OPR}	-20 ~ +85	
Storage Temperature	T_{STG}	-40 ~ +150	

Note: Absolute maximum ratings are those values beyond which the device could be permanently damaged.

Absolute maximum ratings are stress ratings only and functional device operation is not implied.

■ RECOMMENDED OPERATING CONDITIONS ($V_{SS}=0V$)

PARAMETER	SYMBOL	RATINGS	UNIT
DC Supply Voltage	V_{DD}	3 ~ 15	V
Input Voltage	V_{IN}	0 ~ V_{DD}	V
Operating Temperature Range	T_a	-40 ~ +85	

■ DC ELECTRICAL CHARACTERISTICS ($V_{SS}=0V$, $T_a=25$, unless otherwise specified.)

PARAMETER	SYMBOL	CONDITIONS	MIN	TYP	MAX	UNIT
Quiescent Device Current	I_{DD}	$V_{DD}=5V$, $V_{IN}=V_{DD}$ or V_{SS} $V_{DD}=10V$, $V_{IN}=V_{DD}$ or V_{SS} $V_{DD}=15V$, $V_{IN}=V_{DD}$ or V_{SS}			1.0 2.0 4.0	μA
Low Level Output Voltage	V_{OL}	$ I_O < 1\mu A$ $V_{DD}=5V$ $V_{DD}=10V$ $V_{DD}=15V$		0 0 0	0.05 0.05 0.05	V
High Level Output Voltage	V_{OH}	$ I_O < 1\mu A$ $V_{DD}=5V$ $V_{DD}=10V$ $V_{DD}=15V$	4.95 9.95 14.95			V
Low Level Input Voltage	V_{IL}	$ I_O < 1\mu A$ $V_{DD}=5V$, $V_{OUT}=4.5V$ $V_{DD}=10V$, $V_{OUT}=9V$ $V_{DD}=15V$, $V_{OUT}=13.5V$			1.0 2.0 3.0	V
High Level Input Voltage	V_{IH}	$ I_O < 1\mu A$ $V_{DD}=5V$, $V_{OUT}=0.5V$ $V_{DD}=10V$, $V_{OUT}=1V$ $V_{DD}=15V$, $V_{OUT}=1.5V$	4.0 8.0 12.0			V
Low Level Output Current (Note 3)	I_{OL}	$V_{DD}=5V$, $V_{OUT}=0.4V$ $V_{DD}=10V$, $V_{OUT}=0.5V$ $V_{DD}=15V$, $V_{OUT}=1.5V$	0.44 1.1 3.0	0.88 2.25 8.8		mA
High Level Output Current (Note 3)	I_{OH}	$V_{DD}=5V$, $V_{OUT}=4.6V$ $V_{DD}=10V$, $V_{OUT}=9.5V$ $V_{DD}=15V$, $V_{OUT}=13.5V$	-0.44 -1.1 -3.0	-0.88 -2.25 -8.8		mA
Input Current	I_{IN}	$V_{DD}=15V$, $V_{IN}=0V$ $V_{DD}=15V$, $V_{IN}=15V$		-10^{-5} 10^{-5}	-0.30 0.30	μA

■ AC ELECTRICAL CHARACTERISTICS(Note 1)

(Ta=25 , CL=50pF, RL=200kΩ, tr and tr ≤ 20 ns, unless otherwise specified)

PARAMETER	SYMBOL	CONDITIONS	MIN	TYP	MAX	UNIT
Propagation Delay Time from Input to Output	t _{PHL} or t _{PLH}	V _{DD} =5V V _{DD} =10V V _{DD} =15V		50 30 25	90 60 50	ns
Transition Time	t _{THL} or t _{TLH}	V _{DD} =5V V _{DD} =10V V _{DD} =15V		80 50 40	150 100 80	ns
Average Input Capacitance	C _{IN}	Any Gate		6	15	pF
Power Dissipation Capacitance	C _{PD}	Any Gate (Note 3)		12		pF

Note: 1.AC Parameters are guaranteed by DC correlated testing.

2: I_{OH} and I_{OL} are tested one output at a time.

3: C_{PD} determines the no load AC power consumption of any CMOS device.

TYPICAL CHARACTERISTICS

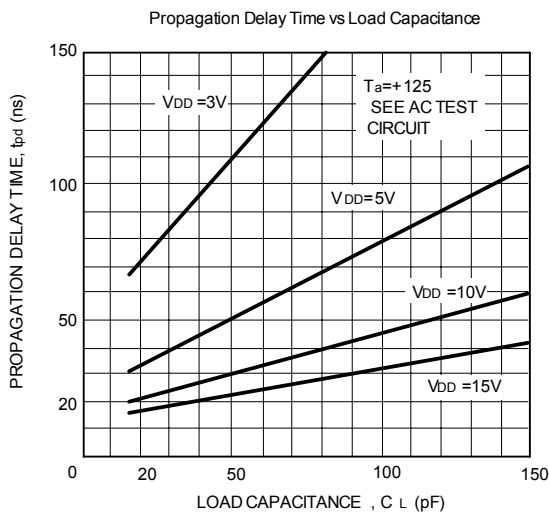
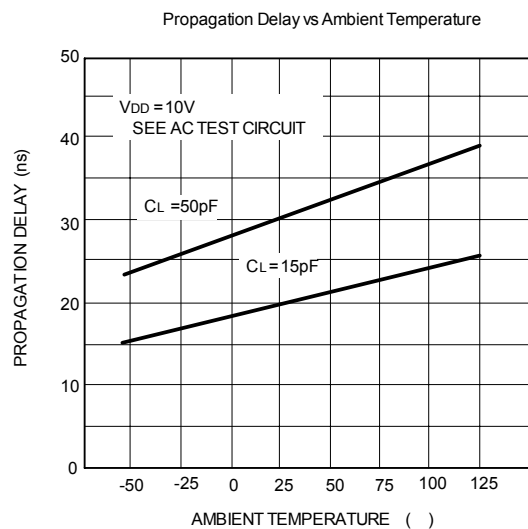
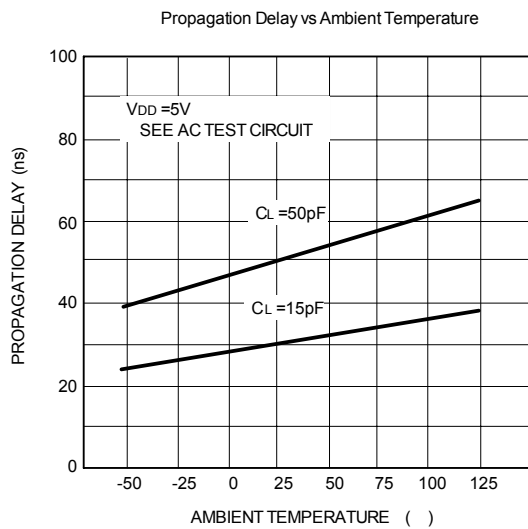
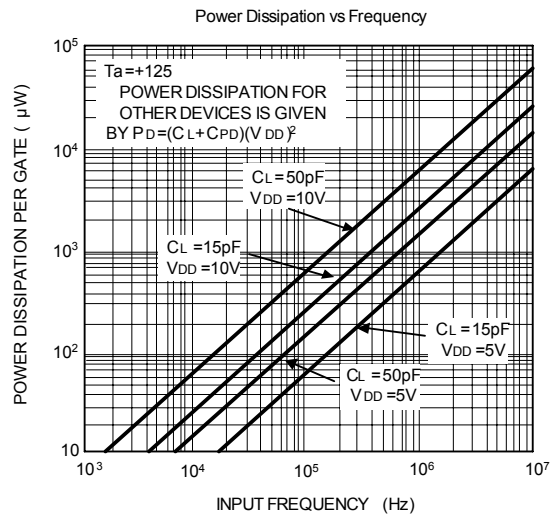
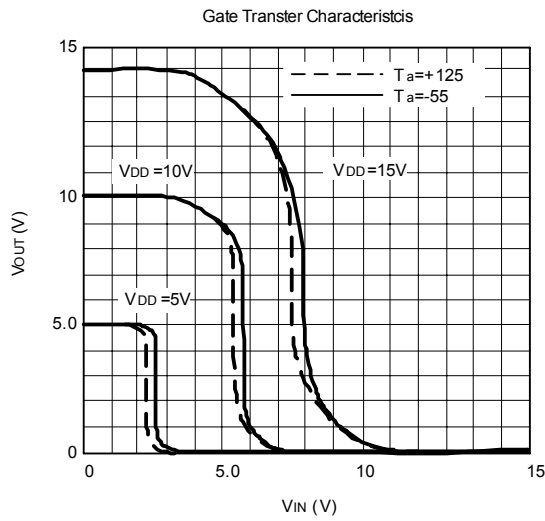

UTC assumes no responsibility for equipment failures that result from using products at values that exceed, even momentarily, rated values (such as maximum ratings, operating condition ranges, or other parameters) listed in products specifications of any and all UTC products described or contained herein. UTC products are not designed for use in life support appliances, devices or systems where malfunction of these products can be reasonably expected to result in personal injury. Reproduction in whole or in part is prohibited without the prior written consent of the copyright owner. The information presented in this document does not form part of any quotation or contract, is believed to be accurate and reliable and may be changed without notice.

单击下面可查看定价，库存，交付和生命周期等信息

[>>UTC\(友顺\)](#)