



7P20

Power MOSFET

-5.7A, -200V P-CHANNEL POWER MOSFET

DESCRIPTION

The **7P20** uses advanced proprietary, planar stripe, DMOS technology to provide excellent $R_{DS(ON)}$, low gate charge and operation with low gate voltages. This device is suitable for use as a load switch or in PWM applications. They are also well suited for high efficiency switching DC/DC converters.

FEATURES

- * $R_{DS(ON)} \leq 0.69\Omega @ V_{GS} = -10V, I_D = -2.85A$
- * Ultra Low Gate Charge (typical 19 nC)
- * Low Reverse Transfer Capacitance ($C_{RSS} = \text{Typical } 25 \text{ pF}$)
- * Fast Switching Capability
- * Avalanche Energy Specified
- * Improved dv/dt Capability, High Ruggedness

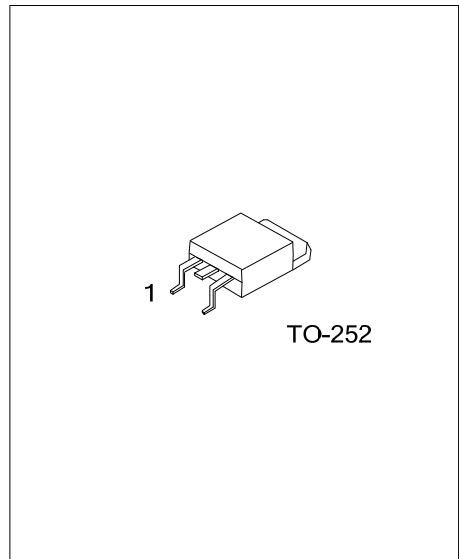

SYMBOL

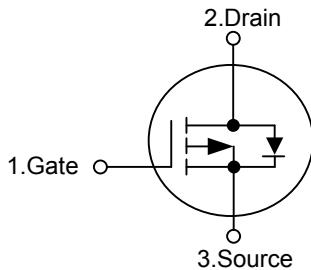

ORDERING INFORMATION

Ordering Number		Package	Pin Assignment			Packing
Lead Free	Halogen Free		1	2	3	
7P20L-TN3-R	7P20G-TN3-R	TO-252	G	D	S	Tape Reel

Note: Pin Assignment: G: Gate D: Drain S: Source

<p>7P20G-TN3-R</p> <p>(1)Packing Type</p> <p>(2)Package Type</p> <p>(3)Green Package</p>	<p>(1) R: Tape Reel</p> <p>(2) TN3: TO-252</p> <p>(3) G: Halogen Free and Lead Free L: Lead Free</p>
--	--

■ MARKING

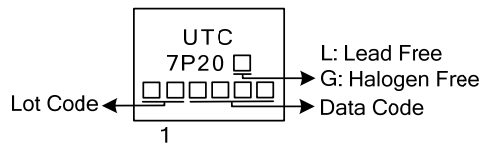

■ ABSOLUTE MAXIMUM RATINGS ($T_C = 25^\circ\text{C}$, unless otherwise specified)

PARAMETER	SYMBOL	RATINGS	UNIT
Drain-Source Voltage	V_{DSS}	-200	V
Gate-Source Voltage	V_{GSS}	± 30	V
Continuous Drain Current	I_D	-5.7	A
Pulsed Drain Current (Note 2)	I_{DM}	-22.8	A
Avalanche Current (Note 2)	I_{AR}	-5.7	A
Single Pulsed Avalanche Energy (Note 3)	E_{AS}	570	mJ
Repetitive Avalanche Energy (Note 2)	E_{AR}	5.5	mJ
Peak Diode Recovery dv/dt (Note 4)	dv/dt	-5.5	V/ns
Power Dissipation	$T_A = 25^\circ\text{C}$	2.5	W
	$T_C = 25^\circ\text{C}$	55	
Junction Temperature	T_J	+150	$^\circ\text{C}$
Storage Temperature	T_{STG}	-55 ~ +150	$^\circ\text{C}$

Notes: 1. Absolute maximum ratings are those values beyond which the device could be permanently damaged.

Absolute maximum ratings are stress ratings only and functional device operation is not implied.

2. Repetitive Rating : Pulse width limited by maximum junction temperature.

3. $L=26.3\text{mH}$, $I_{AS}=-5.7\text{A}$, $V_{DD}=-50\text{V}$, $R_G=25\Omega$, Starting $T_J=25^\circ\text{C}$.

4. $I_{SD}\leq-7.3\text{A}$, $di/dt\leq 300\text{A}/\mu\text{s}$, $V_{DD}\leq BV_{DSS}$, Starting $T_J=25^\circ\text{C}$.

■ THERMAL DATA

PARAMETER	SYMBOL	RATINGS	UNIT
Junction to Ambient	θ_{JA}	100	$^\circ\text{C}/\text{W}$
Junction to Case	θ_{JC}	2.27	$^\circ\text{C}/\text{W}$

■ ELECTRICAL CHARACTERISTICS (T_c=25°C, unless otherwise specified)

PARAMETER	SYMBOL	TEST CONDITIONS	MIN	TYP	MAX	UNIT
OFF CHARACTERISTICS						
Drain-Source Breakdown Voltage	BV _{DSS}	V _{GS} =0 V, I _D =-250 μA	-200			V
Breakdown Voltage Temperature Coefficient	ΔBV _{DSS} /ΔT _J	I _D =-250μA, Referenced to 25°C		-0.1		V/°C
Drain-Source Leakage Current	I _{DSS}	V _{DS} =-200V, V _{GS} =0V			-1	μA
Gate-Source Leakage Current	I _{GSS}	V _{DS} =0V, V _{GS} =±30V			±100	nA
ON CHARACTERISTICS						
Gate Threshold Voltage	V _{GS(TH)}	V _{DS} =V _{GS} , I _D =-250μA	-2.0		-4.0	V
Static Drain-Source On-Resistance	R _{DS(ON)}	V _{GS} =-10V, I _D =-2.85A		0.54	0.69	Ω
Forward Transconductance	g _{FS}	V _{DS} =-40V, I _D =-2.85A (Note 1)		3.7		S
DYNAMIC PARAMETERS						
Input Capacitance	C _{ISS}	V _{DS} =-25V, V _{GS} =0V, f=1.0MHz		590	770	pF
Output Capacitance	C _{OSS}			140	180	pF
Reverse Transfer Capacitance	C _{RSS}			25	35	pF
SWITCHING PARAMETERS						
Total Gate Charge	Q _G	V _{DS} =-160V, V _{GS} =-10V, I _D =-7.3A (Note 1, 2)		19	25	nC
Gate Source Charge	Q _{GS}			4.6		nC
Gate Drain Charge	Q _{GD}			9.5		nC
Turn-ON Delay Time	t _{D(ON)}	V _{DD} =-100V, I _D =-7.3A, R _G =25Ω (Note 1, 2)		15	40	ns
Turn-ON Rise Time	t _R			110	230	ns
Turn-OFF Delay Time	t _{D(OFF)}			30	70	ns
Turn-OFF Fall-Time	t _F			42	90	ns
SOURCE- DRAIN DIODE RATINGS AND CHARACTERISTICS						
Maximum Body-Diode Continuous Current	I _S				-5.7	A
Maximum Pulsed Drain-Source Diode Forward Current	I _{SM}				-22.8	A
Diode Forward Voltage	V _{SD}	I _S =-5.7A, V _{GS} =0V			-5.0	V
Body Diode Reverse Recovery Time	t _{rr}	V _{GS} =0V, I _S =-7.30 A dI _F /dt=100A/s (Note 1)		180		ns
Body Diode Reverse Recovery Charge	Q _{rr}				1.07	

Notes: 1. Pulse Test : Pulse width ≦ 300μs, Duty cycle ≦ 2%.

2. Essentially independent of operating temperature.

■ TEST CIRCUITS AND WAVEFORMS

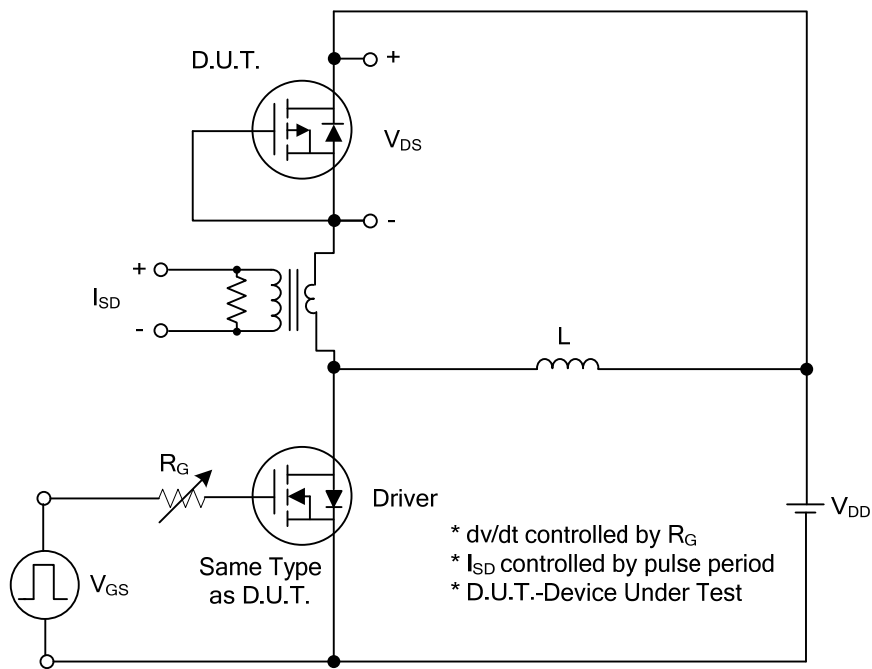

Peak Diode Recovery dv/dt Test Circuit

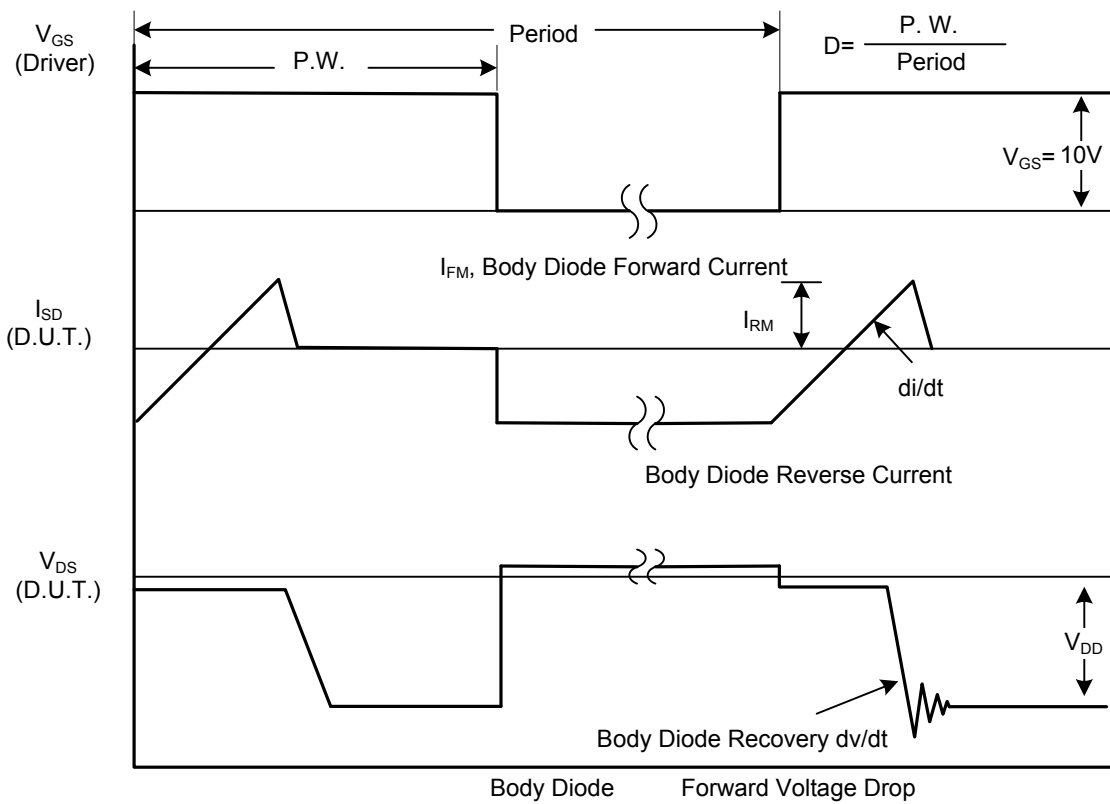

Peak Diode Recovery dv/dt Waveforms

■ TEST CIRCUITS AND WAVEFORMS (Cont.)

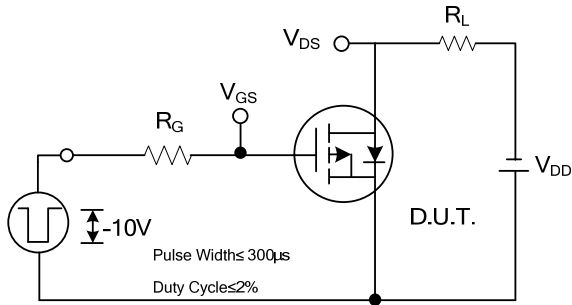

Fig. 2A Switching Test Circuit

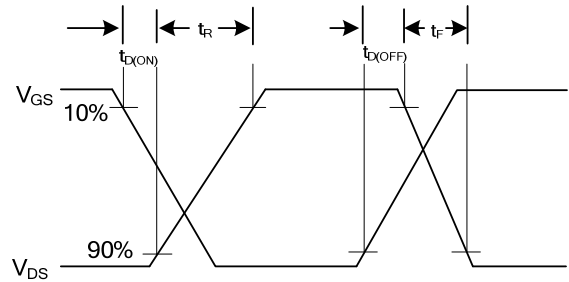

Fig. 2B Switching Waveforms

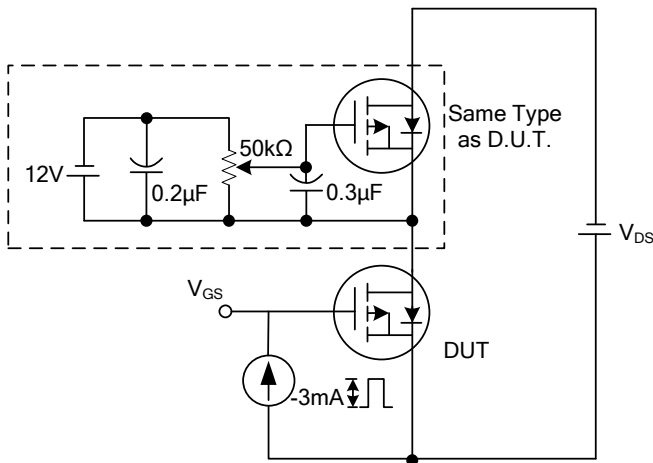

Fig. 3A Gate Charge Test Circuit

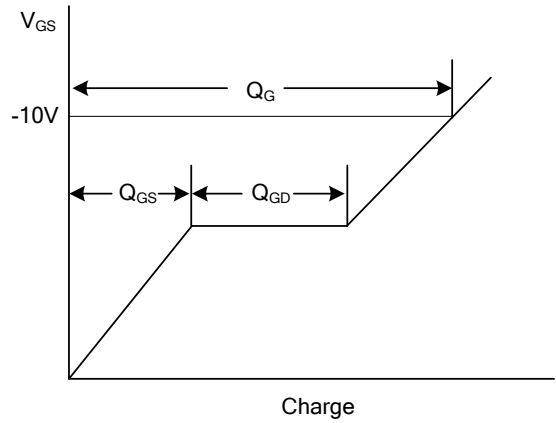

Fig. 3B Gate Charge Waveform

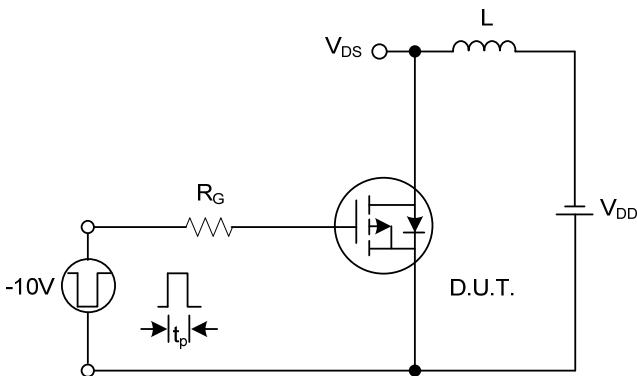

Fig. 4A Unclamped Inductive Switching Test Circuit

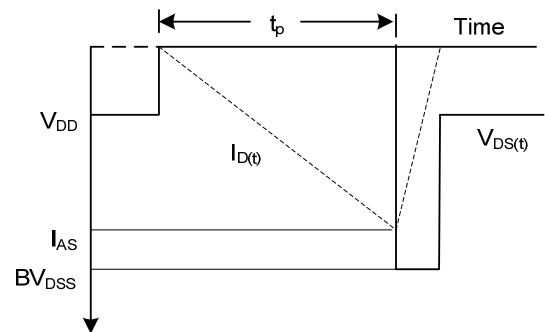
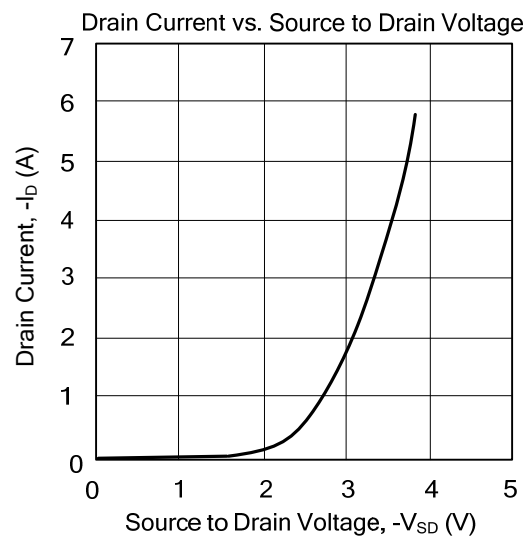
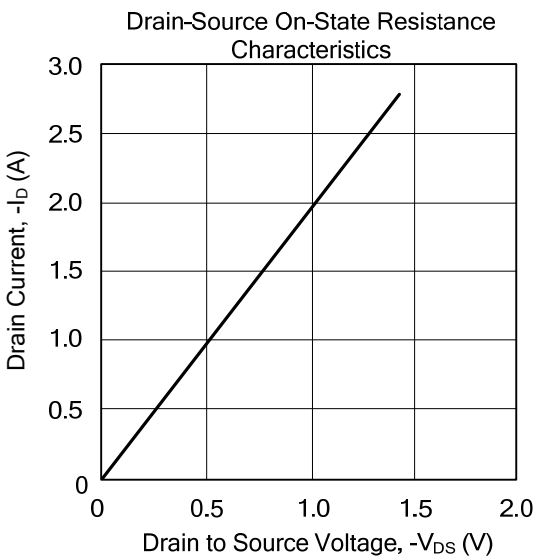
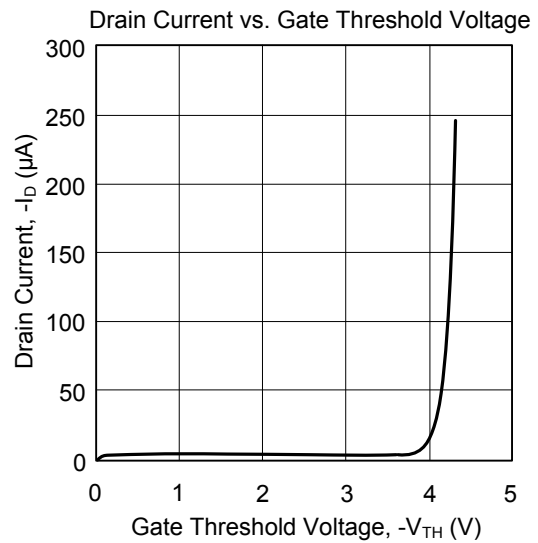
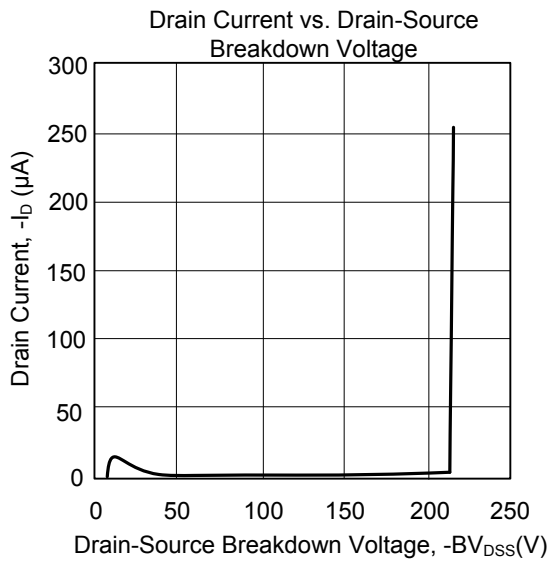

Fig. 4B Unclamped Inductive Switching Waveforms

■ TYPICAL CHARACTERISTICS



UTC assumes no responsibility for equipment failures that result from using products at values that exceed, even momentarily, rated values (such as maximum ratings, operating condition ranges, or other parameters) listed in products specifications of any and all UTC products described or contained herein. UTC products are not designed for use in life support appliances, devices or systems where malfunction of these products can be reasonably expected to result in personal injury. Reproduction in whole or in part is prohibited without the prior written consent of the copyright owner. The information presented in this document does not form part of any quotation or contract, is believed to be accurate and reliable and may be changed without notice.

单击下面可查看定价，库存，交付和生命周期等信息

[>>UTC\(友顺\)](#)