



U74LVC1G07

CMOS IC

BUFFER/DRIVER WITH OPEN-DRAIN OUTPUT

DESCRIPTION

The **U74LVC1G07** is a single Buffer/Driver with open-drain output. This device has power-down protective circuit, preventing device destruction when it is powered down.

FEATURES

- * Inputs and open-drain output accept voltage up to 5.5V
- * Low power Current: $I_{CC}=10\mu A(\text{Max})$
- * $\pm 24\text{mA}$ output drive ($V_{CC}=3.3\text{V}$)
- * Power down protection

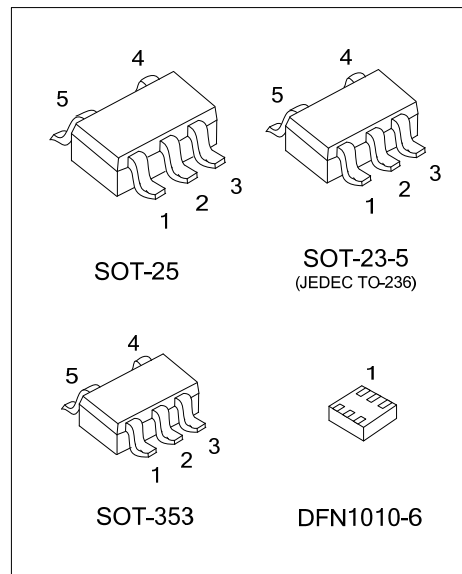

ORDERING INFORMATION

Ordering Number		Package	Packing
Lead Free	Halogen Free		
U74LVC1G07G-AE5-R	U74LVC1G07G-AE5-R	SOT-23-5	Tape Reel
U74LVC1G07G-AF5-R	U74LVC1G07G-AF5-R	SOT-25	Tape Reel
U74LVC1G07G-AL5-R	U74LVC1G07G-AL5-R	SOT-353	Tape Reel
U74LVC1G07G-K06-1010-R	U74LVC1G07G-K06-1010-R	DFN1010-6	Tape Reel

<p>U74LVC1G07G-AE5-R</p> <p>(1) Packing Type (2) Package Type (3) Green Package</p>	<p>(1) R: Tape Reel (2) AE5: SOT-23-5, AF5: SOT-25, AL5: SOT-353 K06-1010: DFN1010-6 (3) G: Halogen Free and Lead Free, L: Lead Free</p>
---	--

MARKING

SOT-23-5 / SOT-25 / SOT-353	DFN1010-6
<p>L: Lead Free G: Halogen Free</p>	

■ PIN CONFIGURATION

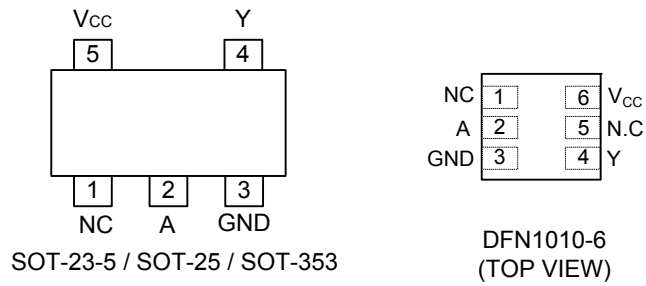

■ FUNCTION TABLE (each gate)

INPUT(A)	OUTPUT(Y)
H	Z
L	L

■ LOGIC DIAGRAM (positive logic)

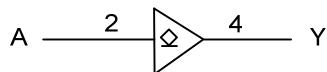

■ ABSOLUTE MAXIMUM RATING (T_A=25°C, unless otherwise specified)

PARAMETER	SYMBOL	TEST CONDITIONS	RATINGS	UNIT
Supply Voltage	V _{CC}		-0.5 ~ 6.5	V
Input Voltage	V _{IN}		-0.5 ~ 6.5	V
Output Voltage	V _{OUT}	Active	-0.5 ~ 6.5	V
		Power-Down	-0.5 ~ 6.5	V
Continuous V _{CC} or GND Current	I _{CC}		±100	mA
Continuous Output Current	I _{OUT}		±50	mA
Input Clamp Current	I _{IK}	V _{IN} <0	-50	mA
Output Clamp Current	I _{OK}	V _{OUT} <0	-50	mA
Storage Temperature Range	T _{STG}		-65 ~ +150	°C

Note: Absolute maximum ratings are those values beyond which the device could be permanently damaged. Absolute maximum ratings are stress ratings only and functional device operation is not implied.

■ RECOMMENDED OPERATING CONDITIONS

PARAMETER	SYMBOL	CONDITIONS	MIN	TYP	MAX	UNIT
Supply Voltage	V _{CC}	Operating	1.65		5.5	V
		Data retention only	1.5			V
Input Voltage	V _{IN}		0		5.5	V
Output Voltage	V _{OUT}		0		5.5	V
Operating Temperature	T _{OPR}		-40		+125	°C

■ STATIC CHARACTERISTICS (T_A=25°C, unless otherwise specified)

PARAMETER	SYMBOL	TEST CONDITIONS	MIN	TYP	MAX	UNIT
High-Level Input Voltage	V _{IH}	V _{CC} =1.65V~1.95V	0.65×V _{CC}			V
		V _{CC} =2.3V~2.7V	1.7			V
		V _{CC} =3.0V~3.6V	2			V
		V _{CC} =4.5V~5.5V	0.7×V _{CC}			V
Low-Level Input Voltage	V _{IL}	V _{CC} =1.65V~1.95V			0.35×V _{CC}	V
		V _{CC} =2.3V~2.7V			0.7	V
		V _{CC} =3.0V~3.6V			0.8	V
		V _{CC} =4.5V~5.5V			0.3×V _{CC}	V
Low-Level Output Voltage	V _{OL}	V _{CC} =1.65V ~ 5.5V, I _{OL} =100μA			0.1	V
		V _{CC} =1.65V, I _{OL} =4mA			0.45	V
		V _{CC} =2.3V, I _{OL} =8mA			0.3	V
		V _{CC} =3.0V, I _{OL} =16mA			0.4	V
		V _{CC} =3.0V, I _{OL} =24mA			0.55	V
		V _{CC} =4.5V, I _{OL} =32mA			0.55	V
Input Leakage Current	I _{I(LEAK)}	V _{CC} =0V~5.5V, V _{IN} =V _{CC} or GND			±5	μA
Power OFF Leakage Current	I _{off}	V _{CC} =0V, V _{IN} or V _{CC} =5.5V			±10	μA
OFF-state output current	I _{OZ}	V _{CC} =5.5V, V _{IN} =V _{IH} or V _{IL} , V _{OUT} =V _{CC} or GND		±0.1	±10	μA
Quiescent Supply Current	I _Q	V _{CC} =1.65V~5.5V, V _{IN} =V _{CC} or GND, I _{OUT} =0			10	μA
Additional Quiescent Supply Current	ΔI _Q	V _{CC} =3V~5.5V, One input at V _{CC} -0.6V, other inputs at V _{CC} or GND			500	μA
Input Capacitance	C _{IN}	V _{CC} =3.3V, V _{IN} =V _{CC} or GND		4		pF
Output Capacitance	C _{OUT}	V _{CC} =3.3V, V _{OUT} =V _{CC} or GND		5		pF

■ DYNAMIC CHARACTERISTICS (T_A=25°C, unless otherwise specified)

PARAMETER	SYMBOL	TEST CONDITIONS	MIN	TYP	MAX	UNIT
Propagation delay from input (A) to output(Y)	t _{PLZ} /t _{PZL}	V _{CC} =1.8V±0.15V, C _L =30pF, R _L =1KΩ	2.4		8.3	ns
		V _{CC} =2.5V±0.2V, C _L =30pF, R _L =500Ω	1		5.5	ns
		V _{CC} =3.3V±0.3V, C _L = 50 pF, R _L =500Ω	1.5		4.2	ns
		V _{CC} = 5V±0.5V, C _L = 50 pF, R _L =500Ω	1		3.5	ns

■ OPERATING CHARACTERISTICS (f=10MHz, T_A=25°C, unless otherwise specified)

PARAMETER	SYMBOL	TEST CONDITIONS	MIN	TYP	MAX	UNIT
Power Dissipation Capacitance	C _{PD}	V _{CC} =1.8V	3	3		pF
		V _{CC} =2.5V	3	3		pF
		V _{CC} =3.3V	3	4		pF
		V _{CC} =5V	3	6		pF

TEST CIRCUIT AND WAVEFORMS

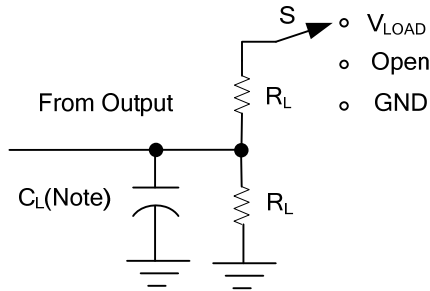

TEST	S
t_{PLH}/t_{PHL}	Open
t_{PHZ}/t_{PZH}	GND
t_{PLZ}/t_{PZL}	V_{LOAD}

Note: C_L includes probe and jig capacitance.

V_{CC}	V_{IN}	t_R/t_F	V_M	V_{LOAD}	C_L	R_L	V_{Δ}
$1.8V \pm 0.15V$	V_{CC}	$\leq 2ns$	$V_{CC}/2$	$2 \times V_{CC}$	30pF	1K Ω	0.15V
$2.5V \pm 0.2V$	V_{CC}	$\leq 2ns$	$V_{CC}/2$	$2 \times V_{CC}$	30pF	500 Ω	0.15V
$3.3V \pm 0.3V$	3 V	$\leq 2.5ns$	1.5V	6V	50pF	500 Ω	0.3V
$5V \pm 0.5V$	V_{CC}	$\leq 2.5ns$	$V_{CC}/2$	$2 \times V_{CC}$	50pF	500 Ω	0.3V

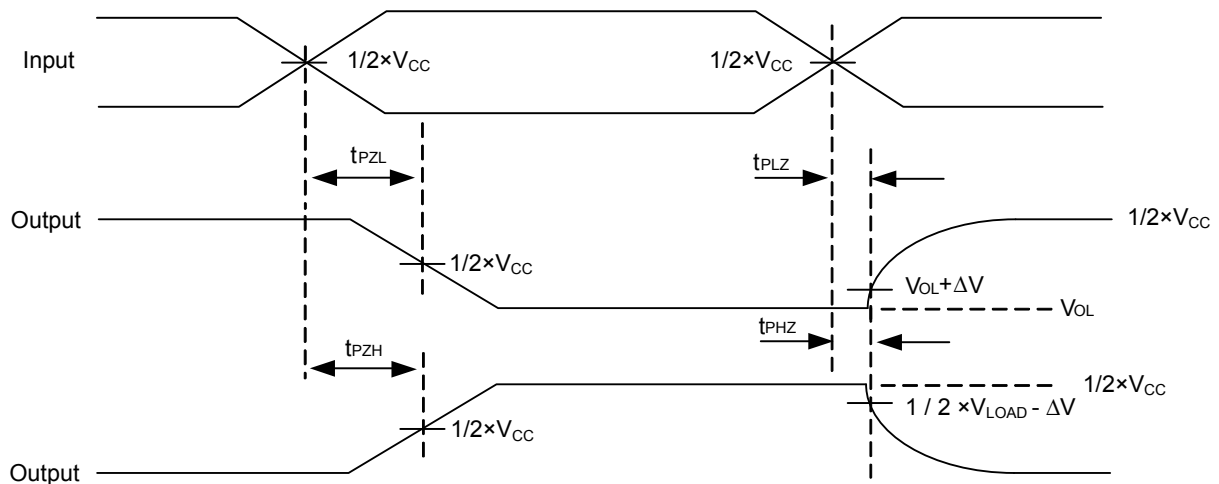

UTC assumes no responsibility for equipment failures that result from using products at values that exceed, even momentarily, rated values (such as maximum ratings, operating condition ranges, or other parameters) listed in products specifications of any and all UTC products described or contained herein. UTC products are not designed for use in life support appliances, devices or systems where malfunction of these products can be reasonably expected to result in personal injury. Reproduction in whole or in part is prohibited without the prior written consent of the copyright owner. UTC reserves the right to make changes to information published in this document, including without limitation specifications and product descriptions, at any time and without notice. This document supersedes and replaces all information supplied prior to the publication hereof.

单击下面可查看定价，库存，交付和生命周期等信息

[>>UTC\(友顺\)](#)