

Features

- ◆ Low On-Resistance
- ◆ Fast Switching
- ◆ 100% Avalanche Tested
- ◆ Repetitive Avalanche Allowed up to T_{jmax}
- ◆ Lead-Free, RoHS Compliant

Description

VS4110AT designed by the trench processing techniques to achieve extremely low on-resistance. Additional features of this design are a 175°C junction operating temperature, fast switching speed and improved repetitive avalanche rating . These features combine to make this design an extremely efficient and reliable device for use in Motor applications and a wide variety of other applications.

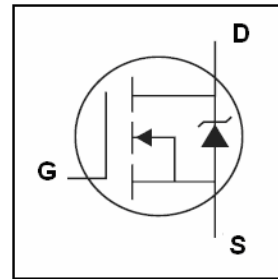

V_{DSS}	100V
$R_{DS(on)}$	4.5m Ω
I_D	180A

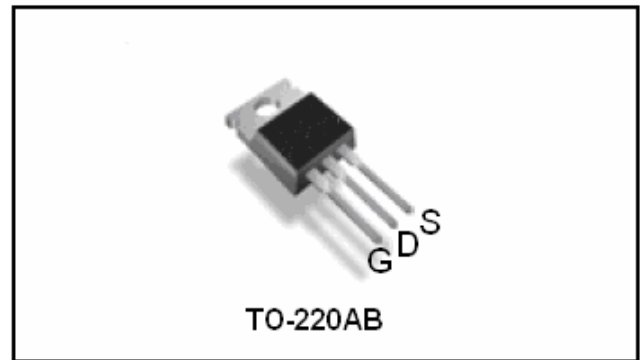
Absolute Maximum Ratings

Stresses beyond those listed under "Absolute Maximum Ratings" may cause permanent damage to the device. These are stress ratings only; and functional operation of the device at these or any other condition beyond those indicated in the specifications is not implied. Exposure to absolute-maximum-rated conditions for extended periods may affect device reliability. The thermal resistance and power dissipation ratings are measured under board mounted and still air conditions. Ambient temperature (T_A) is 25°C, unless otherwise specified.

Symbol	Parameter	Rating	Unit	
Common Ratings ($T_c=25^\circ\text{C}$ Unless Otherwise Noted)				
V_{GS}	Gate-Source Voltage	± 20	V	
$V_{(BR)DSS}$	Drain-Source Breakdown Voltage	100	V	
T_J	Maximum Junction Temperature	175	$^\circ\text{C}$	
T_{STG}	Storage Temperature Range	-55 to 175	$^\circ\text{C}$	
I_S	Maxium Diode Continuous Forward Current	$T_C = 25^\circ\text{C}$	180	A
Mounted on Large Heat Sink				
I_{DM}	Pulse Drain Current Tested ①	$T_C = 25^\circ\text{C}$	650	A
I_D	Continuous Drain current@ $V_{GS}=10\text{V}$	$T_C = 25^\circ\text{C}$	180	A
P_D	Maximum Power Dissipation	$T_C = 25^\circ\text{C}$	350	W
$R_{\theta JC}$	Thermal Resistance-Junction to Case		0.35	$^\circ\text{C/W}$
$R_{\theta JA}$	Thermal Resistance Junction-Ambient		62.5	$^\circ\text{C/W}$
Drain-Source Avalanche Ratings				
EAS	Avalanche Energy, Single Pulsed ②		900	mJ

Symbol	Parameter	Condition	Min.	Typ.	Max.	Unit
Static Electrical Characteristics @ T_J = 25°C (unless otherwise stated)						
V _{(BR)DSS}	Drain-Source Breakdown Voltage	V _{GS} =0V I _D =250μA	100	120	--	V
I _{DSS}	Zero Gate Voltage Drain Current(Tc=25°C)	V _{DS} =100V,V _{GS} =0V	--	--	1	μA
	Zero Gate Voltage Drain Current(Tc=125°C)	V _{DS} =100V,V _{GS} =0V	--	--	100	μA
I _{GSS}	Gate-Body Leakage Current	V _{GS} =±20V,V _{DS} =0V	--	--	±100	nA
V _{GS(TH)}	Gate Threshold Voltage	V _{DS} =V _{GS} ,I _D =250μA	2	--	4	V
R _{DS(ON)}	Drain-Source On-State Resistance ^③	V _{GS} =10V, I _D =80A	--	4.5	5.5	mΩ
g _{fs}	Forward Transconductance	V _{DS} = 10V, I _D =70A	--	120	--	S
Dynamic Electrical Characteristics @ T_J = 25°C (unless otherwise stated)						
C _{iss}	Input Capacitance	V _{DS} =50V,V _{GS} =0V, f=1MHz	--	8950	--	pF
C _{oss}	Output Capacitance		--	620	--	pF
C _{rss}	Reverse Transfer Capacitance		--	245	--	pF
Q _g	Total Gate Charge	V _{DS} =50V,I _D =75A, V _{GS} =10V	--	150	--	nC
Q _{gs}	Gate-Source Charge		--	36	--	nC
Q _{gd}	Gate-Drain Charge		--	40	--	nC
Switching Characteristics						
t _{d(on)}	Turn-on Delay Time	V _{DD} =60V, I _D =30A, R _G =2.8Ω, V _{GS} =10V	--	26	--	nS
t _r	Turn-on Rise Time		--	70	--	nS
t _{d(off)}	Turn-Off Delay Time		--	76	--	nS
t _f	Turn-Off Fall Time		--	90	--	nS
Source- Drain Diode Characteristics @ T_J = 25°C (unless otherwise stated)						
I _{SD}	Source-drain current(Body Diode)	T _c =25°C	--	--	160	A
V _{SD}	Forward on voltage	I _{SD} =80A,V _{GS} =0V	--	0.89	1.3	V
t _{rr}	Reverse Recovery Time	T _J =25°C,I _{SD} =75A, V _{GS} =0V	--	65	--	nS
Q _{rr}	Reverse Recovery Charge	di/dt=100A/μs		125		nC

NOTE:

- ① Pulse width ≤ 300μs; duty cycle ≤ 2%; pulse width limited by max. junction temperature.
 ② Limited by T_{Jmax}, starting T_J = 25°C, L = 0.5mH,R_G = 25Ω, I_{AS} =60A, V_{GS} =10V.

Typical Characteristics

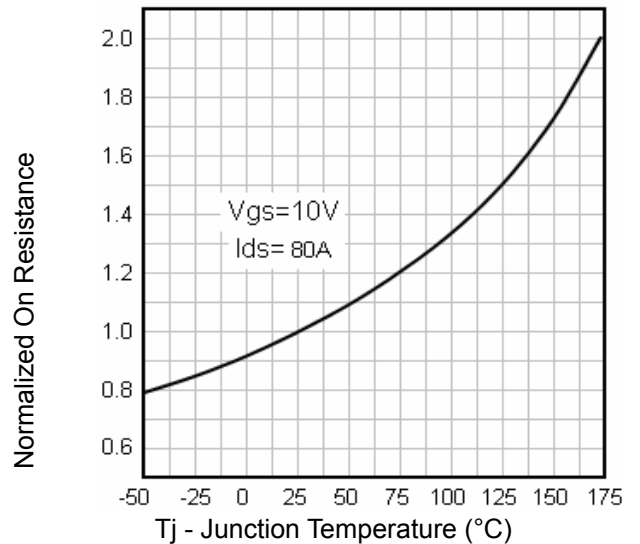
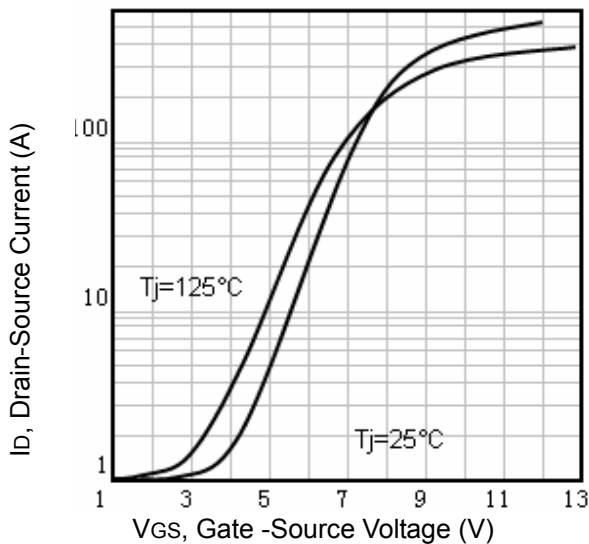
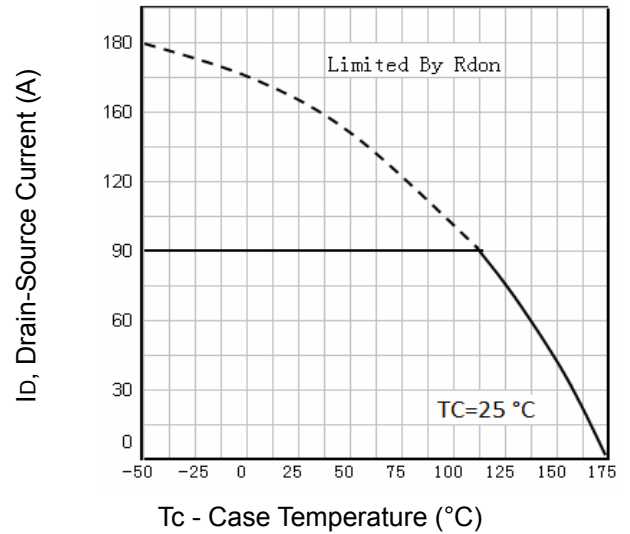
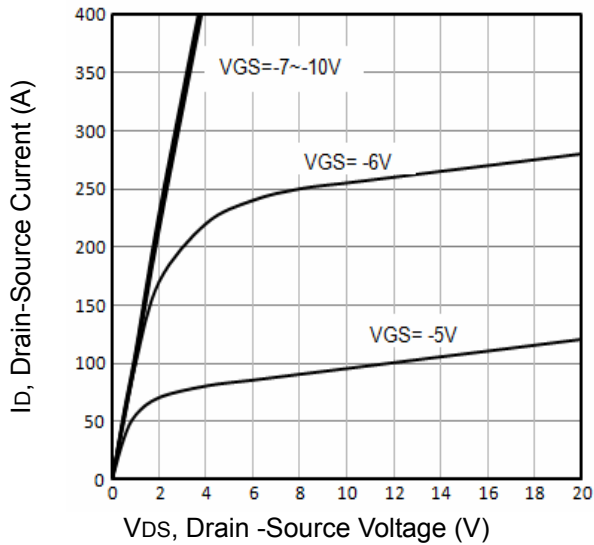

Fig3. Typical Transfer Characteristics

Fig4. Normalized On-Resistance Vs. Temperature

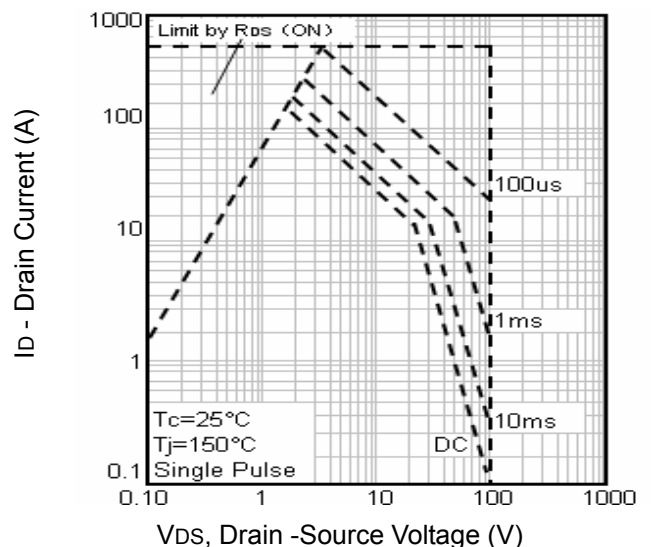
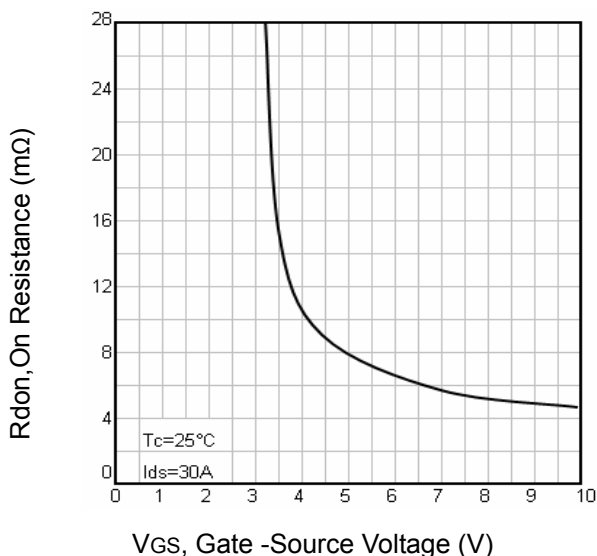

Fig5. Typical On-Resistance Vs. Gate-Source Voltage

Fig6. Maximum Safe Operating Area

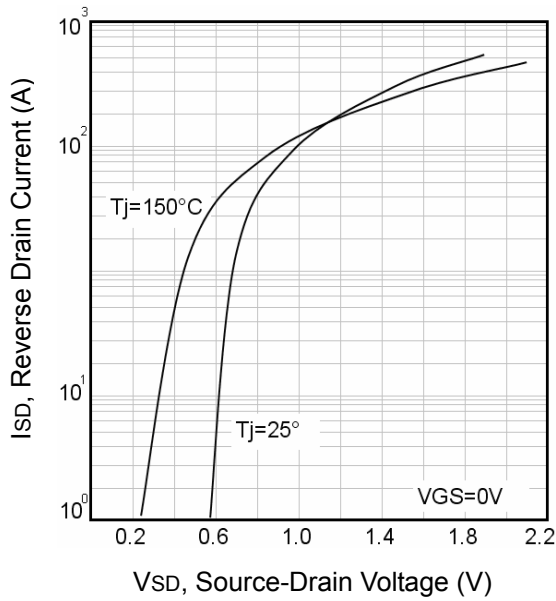

Fig7. Typical Source-Drain Diode Forward Voltage

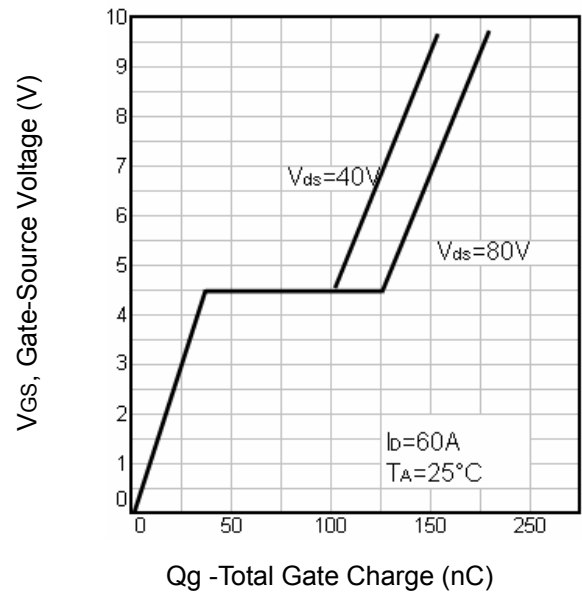

Fig8. Typical Gate Charge Vs. Gate-Source Voltage

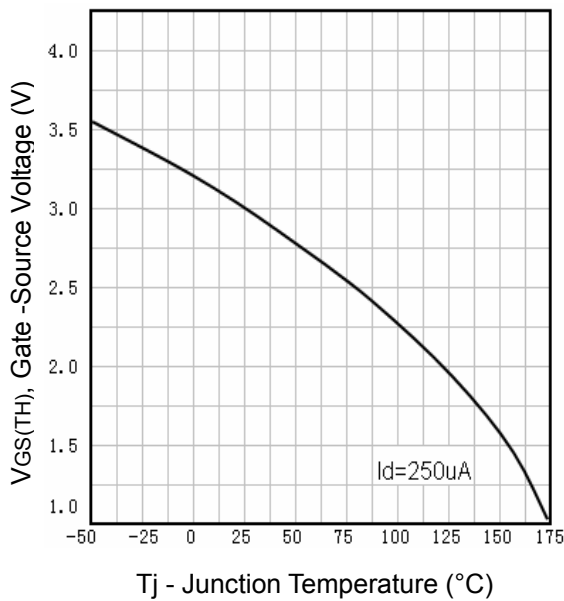

Fig9. Threshold Voltage Vs. Temperature

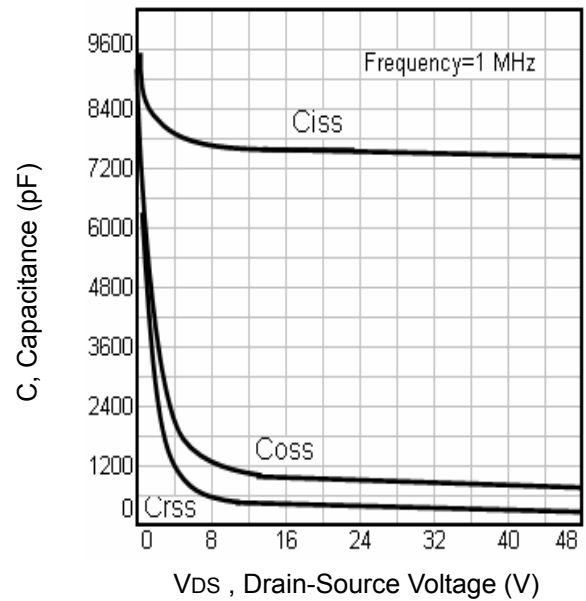

Fig10. Typical Capacitance Vs. Drain-Source Voltage

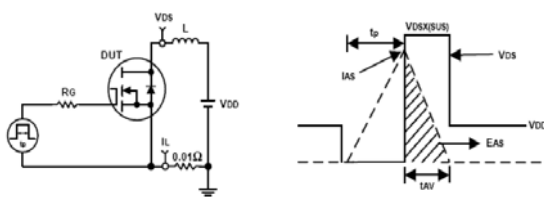

Fig11. Unclamped Inductive Test Circuit and waveforms

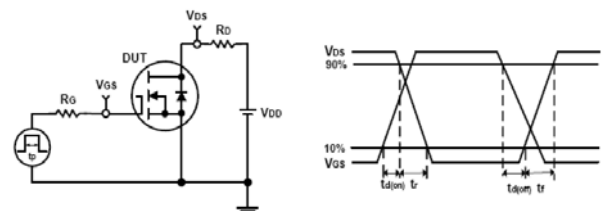
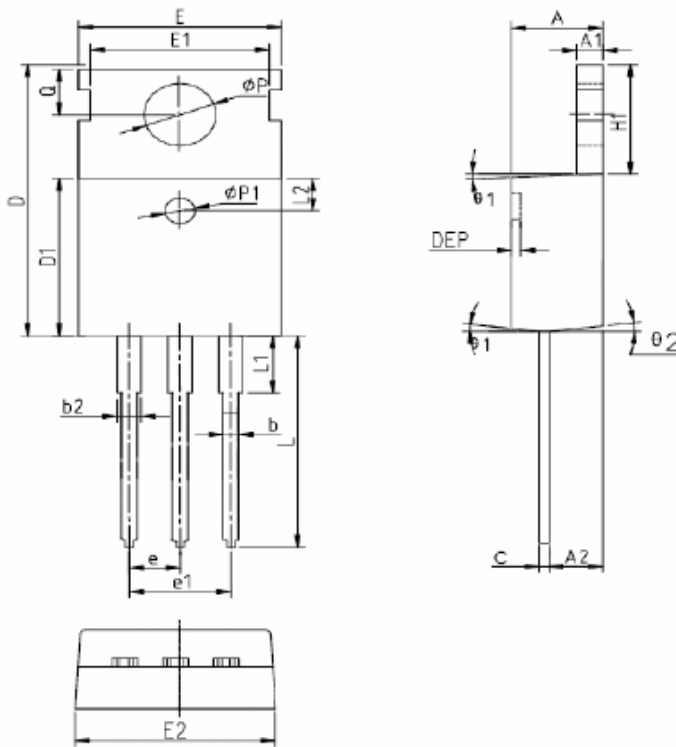

Fig12. Switching Time Test Circuit and waveforms

TO-220 Package Outline



SYMBOL	MM		
	MIN	NOM	MAX
A	4.40	4.57	4.70
A1	1.27	1.30	1.33
A2	2.35	2.40	2.50
b	0.77	-	0.90
b2	1.23	-	1.36
C	0.48	0.50	0.52
D	15.40	15.60	15.80
D1	9.00	9.10	9.20
DEP	0.05	0.10	0.20
E	9.70	9.90	10.10
E1	-	8.70	-
E2	9.80	10.00	10.20
$\phi P1$	1.40	1.50	1.60
e	2.54BSC		
e1	5.08BSC		
H1	6.40	6.50	6.60
L	12.75	-	13.17
L1	-	-	3.95
L2	2.50REF.		
ϕP	3.57	3.60	3.63
Q	2.73	2.80	2.87
$\theta 1$	5°	7°	9°
$\theta 2$	1°	3°	5°

Order Information

Product	Marking	Package	Packaging	Min Unit Quantity
VS4110AT	VS4110AT	TO-220	50PCS/Tube	1000PCS

Customer Service

Sales and Service:

sales@vgsemi.com

Shen Zhen Vanguard Semiconductor CO., LTD

TEL: (86-755) -26902410

FAX: (86-755) -26907027

WEB: www.vgsemi.com

单击下面可查看定价，库存，交付和生命周期等信息

[>>Vanguard Semiconduct\(威兆半导体\)](#)