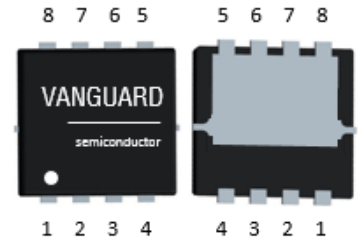

## Features

- Enhancement mode
- Very low on-resistance  $R_{DS(on)}$  @  $V_{GS}=4.5\text{ V}$
- Fast Switching and High efficiency
- 100% Avalanche test
- Pb-free lead plating; RoHS compliant

**Halogen-Free**

$V_{DS}$	30	V
$R_{DS(on),TYP}$ @ $V_{GS}=10\text{ V}$	5.2	m $\Omega$
$R_{DS(on),TYP}$ @ $V_{GS}=4.5\text{ V}$	7.8	m $\Omega$
$I_D$	58	A

**PDFN3333**

Part ID	Package Type	Marking	Tape and reel information
VS3618BE	PDFN3333	3618BE	5000PCS/Reel

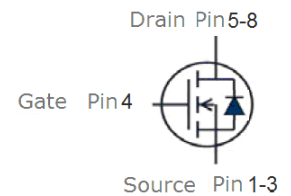

## Maximum ratings, at $T_A = 25^\circ\text{C}$ , unless otherwise specified

Symbol	Parameter	Rating	Unit
$V_{(BR)DSS}$	Drain-Source breakdown voltage	30	V
$V_{GS}$	Gate-Source voltage	$\pm 20$	V
$I_S$	Diode continuous forward current	$T_C = 25^\circ\text{C}$	58 A
$I_D$	Continuous drain current @ $V_{GS}=10\text{V}$	$T_C = 25^\circ\text{C}$	58 A
		$T_C = 100^\circ\text{C}$	37 A
$I_{DM}$	Pulse drain current tested ①	$T_C = 25^\circ\text{C}$	230 A
$I_{DSM}$	Continuous drain current @ $V_{GS}=10\text{V}$	$T_A = 25^\circ\text{C}$	20 A
		$T_A = 70^\circ\text{C}$	16 A
EAS	Avalanche energy, single pulsed ②	46	mJ
$P_D$	Maximum power dissipation	$T_C = 25^\circ\text{C}$	30 W
		$T_C = 100^\circ\text{C}$	12 W
$P_{DSM}$	Maximum power dissipation ③	$T_A = 25^\circ\text{C}$	3.6 W
		$T_A = 70^\circ\text{C}$	2.3 W
$T_{STG}, T_J$	Storage and Junction Temperature Range	-55 to 150	$^\circ\text{C}$

## Thermal Characteristics

Symbol	Parameter	Typical	Unit
$R_{\theta JC}$	Thermal Resistance, Junction-to-Case	4.1	$^\circ\text{C/W}$
$R_{\theta JA}$	Thermal Resistance, Junction-to-Ambient	35	$^\circ\text{C/W}$

**Electrical Characteristics**

Symbol	Parameter	Condition	Min.	Typ.	Max.	Unit
<b>Static Electrical Characteristics @ T<sub>j</sub>=25°C (unless otherwise stated)</b>						
V <sub>(BR)DSS</sub>	Drain-Source Breakdown Voltage	V <sub>GS</sub> =0V, I <sub>D</sub> =250μA	30	--	--	V
I <sub>DSS</sub>	Zero Gate Voltage Drain Current	V <sub>DS</sub> =30V, V <sub>GS</sub> =0V	--	--	1	μA
	Zero Gate Voltage Drain Current(T <sub>j</sub> =125°C)	V <sub>DS</sub> =30V, V <sub>GS</sub> =0V	--	--	100	μA
I <sub>GSS</sub>	Gate-Body Leakage Current	V <sub>GS</sub> =±20V, V <sub>DS</sub> =0V	--	--	±100	nA
V <sub>GS(TH)</sub>	Gate Threshold Voltage	V <sub>DS</sub> =V <sub>GS</sub> , I <sub>D</sub> =250μA	1.3	1.8	2.4	V
R <sub>DS(ON)</sub>	Drain-Source On-State Resistance ④	V <sub>GS</sub> =10V, I <sub>D</sub> =15A	--	5.2	6	mΩ
		T <sub>j</sub> =100°C	--	6.3	--	mΩ
R <sub>DS(ON)</sub>	Drain-Source On-State Resistance ④	V <sub>GS</sub> =4.5V, I <sub>D</sub> =10A	--	7.8	10	mΩ
<b>Dynamic Electrical Characteristics @ T<sub>j</sub> = 25°C (unless otherwise stated)</b>						
C <sub>iss</sub>	Input Capacitance	V <sub>DS</sub> =15V, V <sub>GS</sub> =0V, f=1MHz	985	1160	1335	pF
C <sub>oss</sub>	Output Capacitance		150	180	210	pF
C <sub>rss</sub>	Reverse Transfer Capacitance		110	130	150	pF
R <sub>g</sub>	Gate Resistance	f=1MHz	--	2.0	--	Ω
Q <sub>g</sub> (10V)	Total Gate Charge	V <sub>DS</sub> =15V, I <sub>D</sub> =15A, V <sub>GS</sub> =10V	--	22	--	nC
Q <sub>g</sub> (4.5V)	Total Gate Charge		--	11	--	nC
Q <sub>gs</sub>	Gate-Source Charge		--	3.8	--	nC
Q <sub>gd</sub>	Gate-Drain Charge		--	4.5	--	nC
<b>Switching Characteristics</b>						
t <sub>d(on)</sub>	Turn-on Delay Time	V <sub>DD</sub> =15V, I <sub>D</sub> =15A, R <sub>G</sub> =3.0Ω, V <sub>GS</sub> =10V	--	6.6	--	ns
t <sub>r</sub>	Turn-on Rise Time		--	44	--	ns
t <sub>d(off)</sub>	Turn-Off Delay Time		--	20	--	ns
t <sub>f</sub>	Turn-Off Fall Time		--	9	--	ns
<b>Source- Drain Diode Characteristics @ T<sub>j</sub> = 25°C (unless otherwise stated)</b>						
V <sub>SD</sub>	Forward on voltage	I <sub>SD</sub> =10A, V <sub>GS</sub> =0V	--	0.8	1.2	V
t <sub>rr</sub>	Reverse Recovery Time	T <sub>j</sub> =25°C, I <sub>sd</sub> =15A, V <sub>GS</sub> =0V	--	12	--	ns
Q <sub>rr</sub>	Reverse Recovery Charge	di/dt=100A/μs	--	4.3	--	nC

NOTE:

- ① Repetitive rating; pulse width limited by max junction temperature.
- ② Limited by T<sub>Jmax</sub>, starting T<sub>J</sub> = 25°C, L = 0.5mH, R<sub>G</sub> = 25Ω, I<sub>AS</sub> = 10A, V<sub>GS</sub> = 10V. Part not recommended for use above this value
- ③ The power dissipation P<sub>DSM</sub> is based on R<sub>θJA</sub> and the maximum allowed junction temperature of 150°C.
- ④ Pulse width ≤ 380μs; duty cycle ≤ 2%.

Typical Characteristics

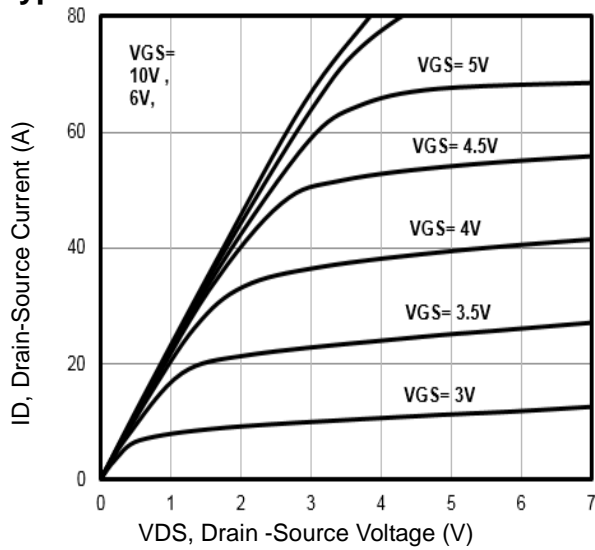

Fig1. Typical Output Characteristics

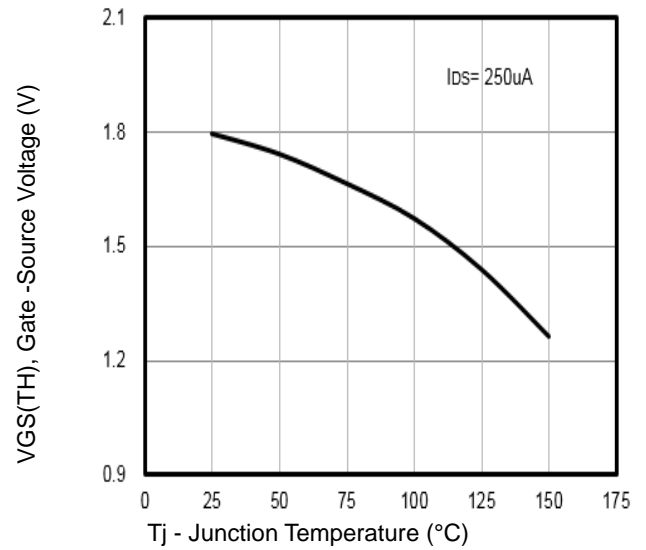

Fig2.  $V_{GS(TH)}$  Gate-Source Voltage Vs.  $T_j$

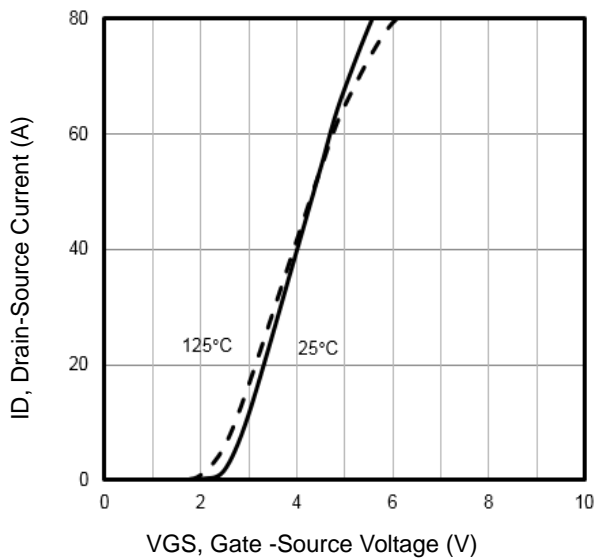

Fig3. Typical Transfer Characteristics

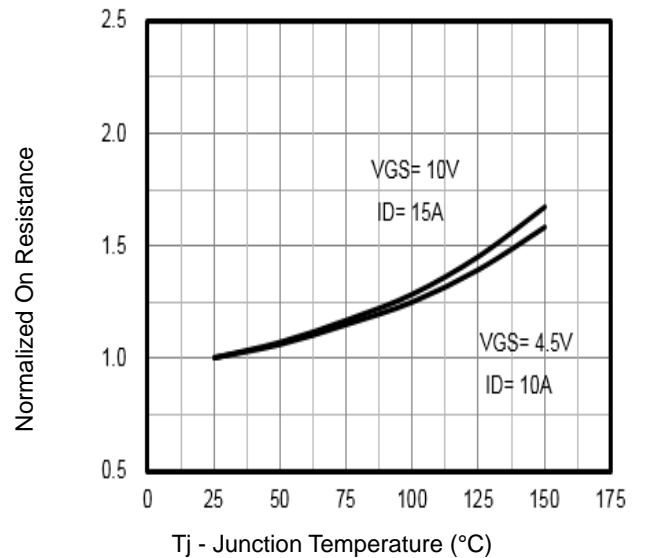

Fig4. Normalized On-Resistance Vs.  $T_j$

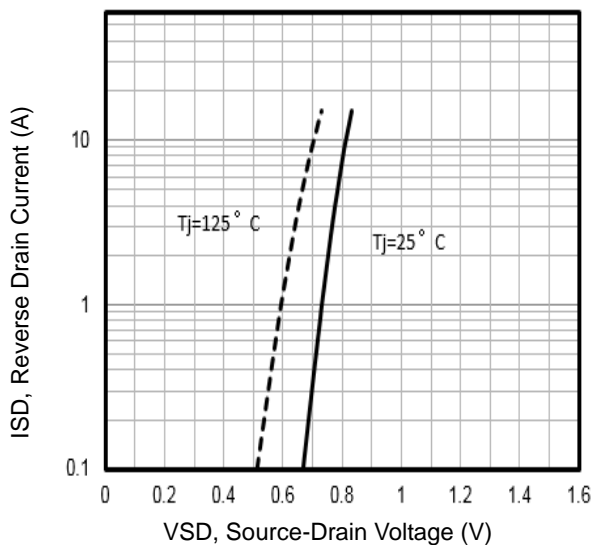

Fig5. Typical Source-Drain Diode Forward Voltage

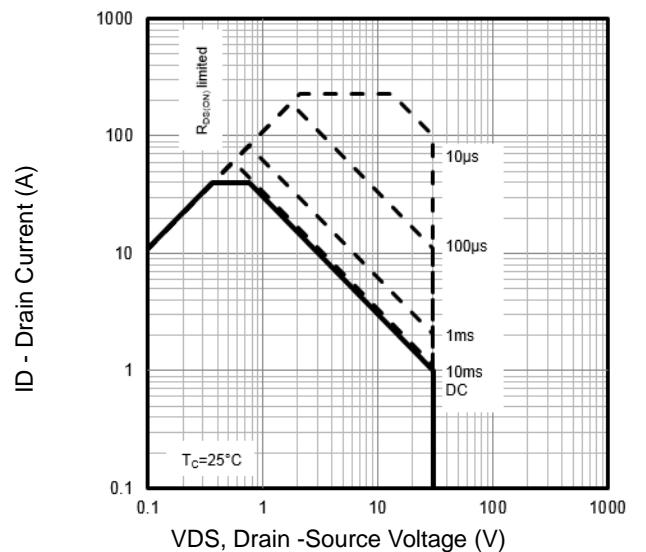

Fig6. Maximum Safe Operating Area

Typical Characteristics

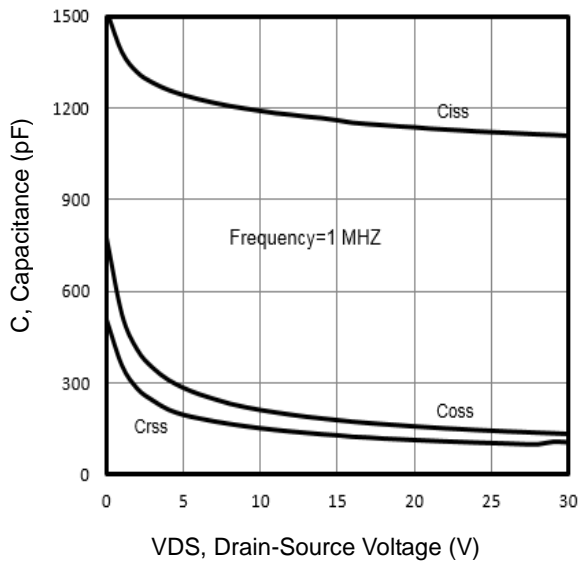

Fig7. Typical Capacitance Vs. Drain-Source Voltage

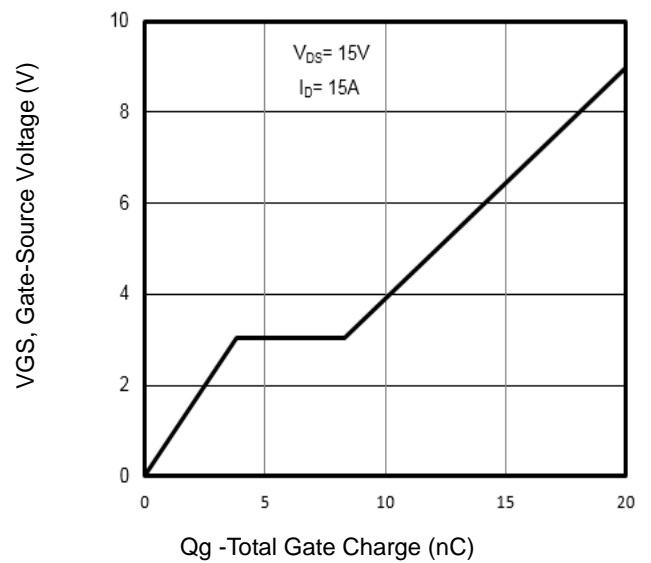

Fig8. Typical Gate Charge Vs. Gate-Source Voltage

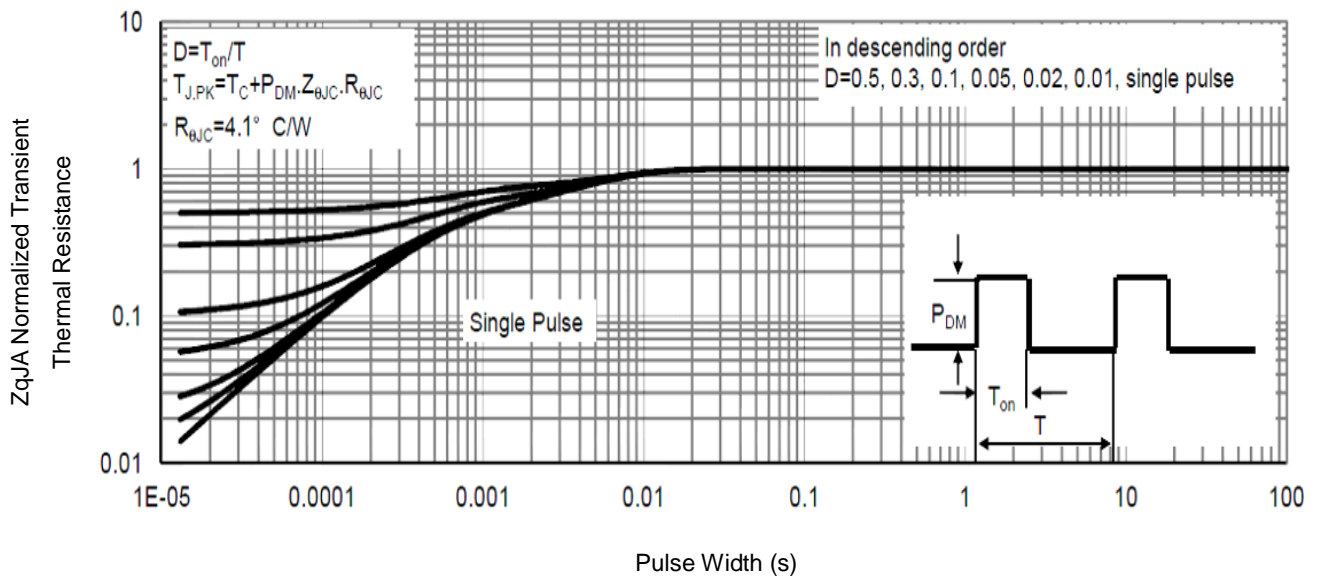

Fig9. Normalized Maximum Transient Thermal Impedance

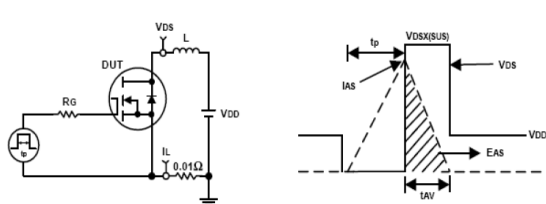

Fig10. Unclamped Inductive Test Circuit and waveforms

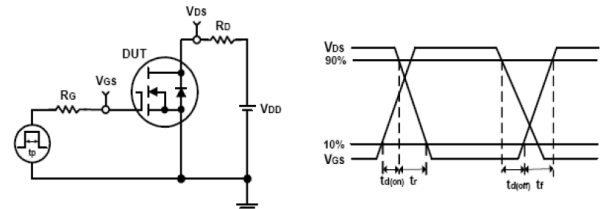
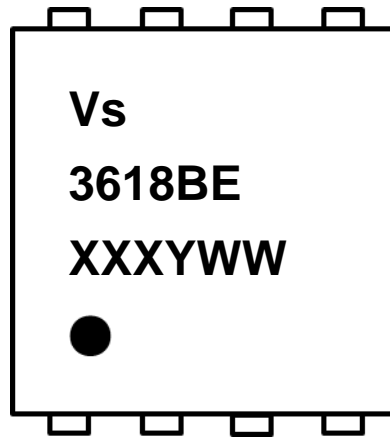

Fig11. Switching Time Test Circuit and waveforms

## Marking Information



1<sup>st</sup> line: Vanguard Code (Vs)

2<sup>nd</sup> line: Part Number (3618BE)

3<sup>rd</sup> line: Date code (XXXYWW)

XXX: Wafer Lot Number Code , code changed with Lot Number

Y: Year Code, (e.g. E=2017, F=2018, G=2019, H=2020, etc)

WW: Week Code (01 to 53)

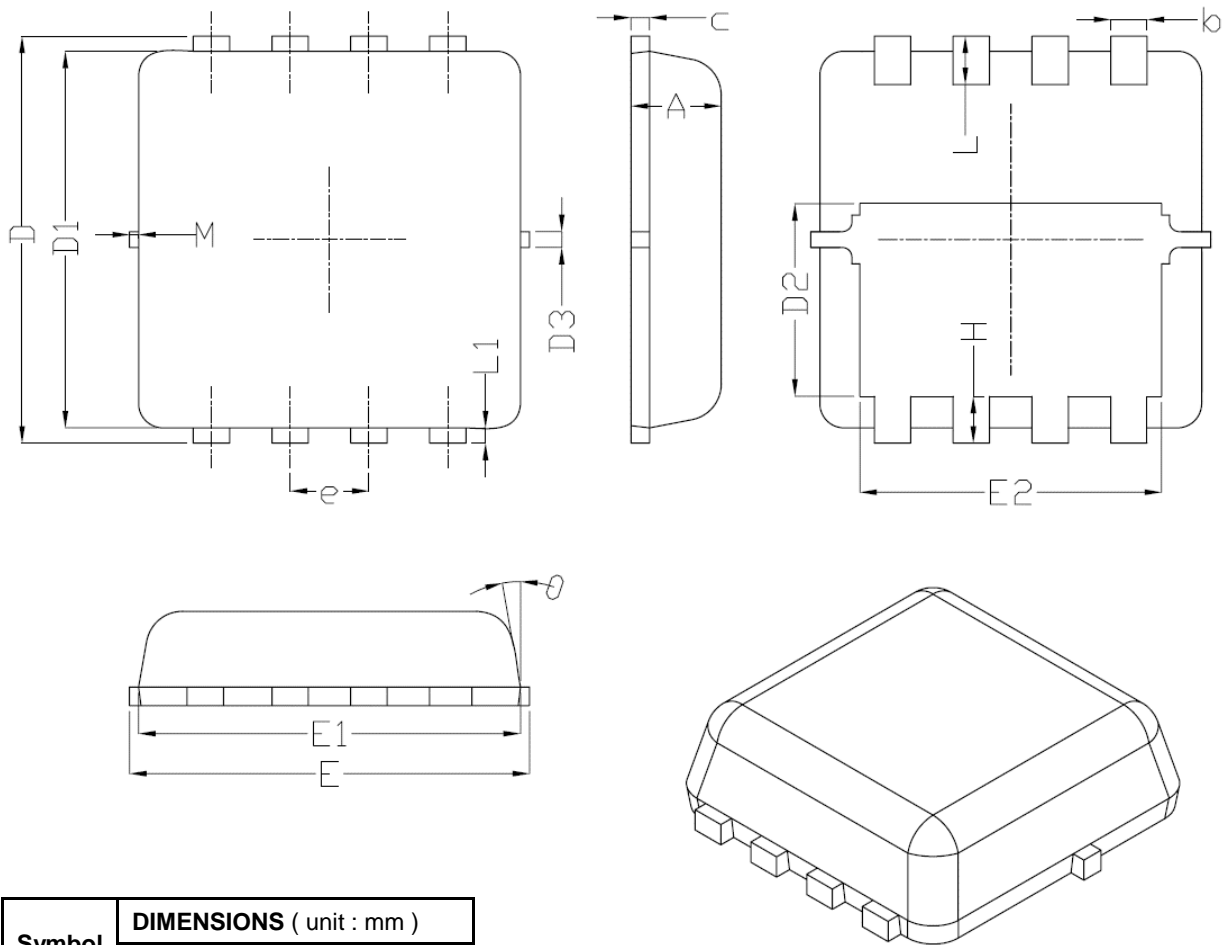
**PDFN3333 Package Outline Data**

Symbol	DIMENSIONS ( unit : mm )		
	Min	Typ	Max
<b>A</b>	0.7	0.75	0.8
<b>b</b>	0.25	0.3	0.35
<b>C</b>	0.1	0.15	0.25
<b>D</b>	3.25	3.35	3.45
<b>D1</b>	3	3.1	3.2
<b>D2</b>	1.48	1.58	1.68
<b>D3</b>	--	0.13	--
<b>E</b>	3.2	3.3	3.4
<b>E1</b>	3	3.15	3.2
<b>E2</b>	2.39	2.49	2.59
<b>e</b>	0.65 BSC		
<b>H</b>	0.3	0.39	0.5
<b>L</b>	0.3	0.4	0.5
<b>L1</b>	--	0.13	--
<b>θ</b>	--	10°	12°
<b>M</b>	*	*	0.15
* Not specified			

**Notes:**

1. Follow JEDEC MO-240 variation CA.
2. Dimensions "D1" and "E1" do NOT include mold flash protrusions or gate burrs.
3. Dimensions "D1" and "E1" include interterminal flash or protrusion. Interterminal flash or protrusion shall not exceed 0.25mm per side.

**Customer Service**
**Sales and Service:**
[sales@vgsemi.com](mailto:sales@vgsemi.com)
**Vanguard Semiconductor CO., LTD**
**TEL:** (86-755) -26902410

**FAX:** (86-755) -26907027

**WEB:** [www.vgsemi.com](http://www.vgsemi.com)

单击下面可查看定价，库存，交付和生命周期等信息

[>>Vanguard Semiconduct\(威兆半导体\)](#)