

## Data Sheet

Customer:

Product: Pulse Withstanding Chip Resistor - PWR Series

Size: 0402/0603/0805/1206/1210/2010/2512

Issued Date: 20-May-19

Edition: REV.C4



VIKING TECH CORPORATION  
光頡科技股份有限公司  
No.70 Guangfu N. Rd., Hukou  
Township, Hsinchu County 303,  
Taiwan

TEL:886-3-5972931  
FAX:886-3-5972935•886-3-5973494  
E-mail:sales@viking.com.tw

VIKING TECH CORPORATION KAOHSIUNG BRANCH  
光頡科技股份有限公司高雄分公司  
No.248-3, Sin-Sheng Rd., Cian-Jhen Dist., Kaohsiung,  
806, Taiwan

TEL:886-7-8217999  
FAX:886-7-8228229  
E-mail:sales@viking.com.tw

VIKING ELECTRONICS (WUXI) CO., LTD.  
光頡電子(無錫)有限公司  
No.22 Xixia Road, Machinery & Industry Park,  
National Hi-Tech Industrial Development Zone  
of Wuxi, Wuxi, Jiangsu Province, China  
Zip Code:214028  
TEL:86-510-85203339  
FAX:86-510-85203667•86-510-85203977  
E-mail:china@viking.com.tw

Produced by (QC)	Checked (QC)	Approved by (QC)	Prepared by (Sales)	Accepted by (Customer)
20-May-19	20-May-19	20-May-19	20-May-19	
<b>Susan Huang</b>	<b>J.C. Liu</b>	<b>J.C. Liu</b>		

## Pulse Withstanding Chip Resistor – PWR Series

### ■ Features

- Tolerance from  $\pm 0.5\%$ ~ $5\%$
- High power rating
- Excellent pulse withstanding performance
- Improved working voltage ratings
- Standard package sizes of 0402~2512
- AEC-Q200 Compliance



### ■ Applications

- Metering (Testing/Measurement)
- Diagnostic Equipment
- Medical Devices
- Industrial Controls
- Plasma
- LCD Video Monitors

### ■ Construction

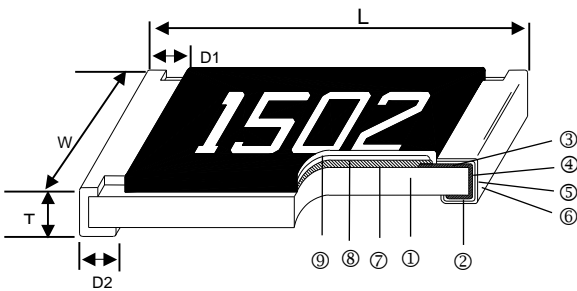

① Alumina Substrate	⑥ External Electrode
② Bottom Electrode	⑦ Resistor Layer
③ Top Electrode	⑧ Primary Overcoat
④ Edge Electrode	⑨ Secondary Overcoat
⑤ Barrier Layer	

### ■ Dimensions

Type	Size (Inch)	L (mm)	W (mm)	T (mm)	D1 (mm)	D2 (mm)	Weight (g) (1000pcs)
PWR02	0402	1.00±0.05	0.50±0.05	0.35±0.05	0.20±0.10	0.20±0.10	0.63
PWR03	0603	1.60±0.10	0.80±0.10	0.45±0.10	0.30±0.20	0.30±0.20	2.042
PWR05	0805	2.00±0.10	1.25±0.10	0.50±0.10	0.35±0.20	0.40±0.20	4.368
PWR05 (1/2W)	0805	2.00±0.10	1.25±0.10	0.50±0.10	0.35±0.20	0.40±0.20	5.049
PWR06	1206	3.10±0.10	1.55±0.10	0.55±0.10	0.50±0.25	0.50±0.20	8.947
PWR06 (3/4W)	1206	3.10±0.10	1.55±0.10	0.55±0.10	0.50±0.25	0.50±0.20	9.541
PWR13	1210	3.10±0.10	2.60±0.15	0.55±0.10	0.50±0.25	0.50±0.20	15.959
PWR10	2010	5.00±0.10	2.50±0.15	0.55±0.10	0.60±0.25	0.50±0.20	24.241
PWR12	2512	6.35±0.10	3.10±0.15	0.55±0.10	0.60±0.25	0.50±0.20	39.448

### ■ Derating Curve

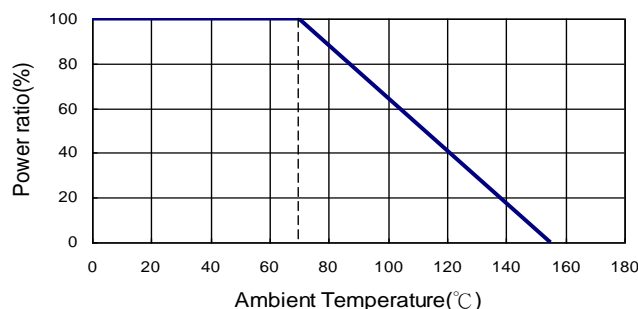

**Part Numbering**

PWR	12	J	T	E	A	1001	
Product Type	Dimensions	Resistance Tolerance	Packaging Code	TCR (PPM/°C)	Power Rating	Resistance	Marking
	02: 0402 03: 0603 05: 0805 06: 1206 13: 1210 10: 2010 12: 2512	D: ±0.5% F: ±1% J: ±5%	T: Taping Reel	E: ±100 F: ±200 G: ±300	A: 1.5W T: 1W Q: 3/4W U: 1/2W G: 2/5W O: 1/3W V: 1/4W W: 1/8W X: 1/10W P: 1/5W	1001: 1KΩ 1004: 1MΩ	: Standard Marking N: No Marking

**Standard Electrical Specifications**

Item Type	Power Rating at 70°C	Operating Temp. Range	Max. Operating Voltage	Max. Overload Voltage	Resistance Range			TCR (PPM/°C)
					±0.5% (E24,E96)	±1% (E24,E96)	±5% (E24)	
PWR02 (0402)	1/5W	-55 ~ +155°C	50V	100V	-	1Ω-20Ω		±300
					100Ω-1MΩ	20.5Ω-1MΩ		±100
PWR03 (0603)	1/10W	-55 ~ +155°C	50V	100V	10Ω - 294Ω	1Ω - 294Ω		±200
					300Ω - 1MΩ			±100
PWR05 (0805)	1/8W	-55 ~ +155°C	150V	300V	10Ω - 294Ω	1Ω - 294Ω		±200
					300Ω - 20MΩ			±100
PWR06 (1206)	1/3W	-55 ~ +155°C	200V	400V	10Ω - 20Ω	1Ω - 20Ω		±200
					20.5Ω - 20MΩ			±100
PWR13 (1210)	1/2W	-55 ~ +155°C	200V	400V	10Ω - 20Ω	1Ω - 20Ω		±200
					20.5Ω - 20MΩ			±100
PWR10 (2010)	3/4W	-55 ~ +155°C	400V	800V	10Ω - 20Ω	1Ω - 20Ω		±200
					20.5Ω - 20MΩ			±100
PWR12 (2512)	1.5W	-55 ~ +155°C	500V	1000V	10Ω - 20Ω	1Ω - 20Ω		±200
					20.5Ω - 20MΩ			±100

**High Power & Ultra High Power Rating Electrical Specifications**

Item Type	Power Rating at 70°C	Operating Temp. Range	Max. Operating Voltage	Max. Overload Voltage	Resistance Range			TCR (PPM/°C)
					±0.5% (E24,E96)	±1% (E24,E96)	±5% (E24)	
PWR03 (0603)	1/4W	-55 ~ +155°C	75V	150V	10Ω - 294Ω	1Ω - 294Ω		±200
					300Ω - 1MΩ			±100
PWR05 (0805)	2/5W	-55 ~ +155°C	150V	300V	10Ω - 294Ω	1Ω - 294Ω		±200
					300Ω - 1MΩ			±100
PWR05 (0805)	1/2W *	-55 ~ +155°C	400V	600V	10Ω - 294Ω	1Ω - 294Ω		±200
					300Ω - 1MΩ			±100
PWR06 (1206)	1/2W	-55 ~ +155°C	200V	400V	10Ω - 20Ω	1Ω - 20Ω		±200
					20.5Ω - 1MΩ			±100

**Pulse Withstanding Chip Resistor**

Item Type	Power Rating at 70°C	Operating Temp. Range	Max. Operating Voltage	Max. Overload Voltage	Resistance Range			TCR (PPM/°C)
					±0.5% (E24,E96)	±1% (E24,E96)	±5% (E24)	
PWR06 (1206)	3/4W *	-55 ~ +155°C	500V	1000V	10Ω - 20Ω	1Ω - 20Ω		±200
					20.5Ω - 1MΩ			±100
PWR13 (1210)	3/4W	-55 ~ +155°C	200V	400V	10Ω - 20Ω	1Ω - 20Ω		±200
					20.5Ω - 1MΩ			±100
PWR10 (2010)	1W	-55 ~ +155°C	400V	800V	10Ω - 20Ω	1Ω - 20Ω		±200
					20.5Ω - 1MΩ			±100

\*: Ultra High Power: double side printed resistor element

Operating Voltage= $\sqrt{P \cdot R}$  or Max. Operating Voltage listed above, whichever is lower.

Overload Voltage= $2.5 \cdot \sqrt{P \cdot R}$  or Max. Overload Voltage listed above, whichever is lower.

■ Viking is capable of manufacturing the optional spec based on customer's requirement.

**Soldering Condition**

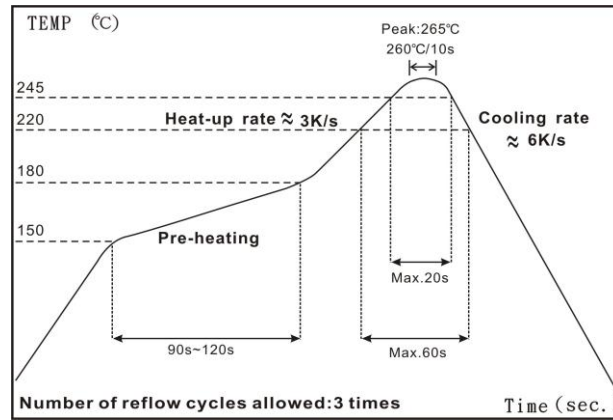

IR Reflow Soldering

(1) Time of IR reflow soldering at maximum temperature point 260°C : 10s

**Environmental Characteristics**

Item	Requirement	Test Method
Temperature Coefficient of Resistance (T.C.R.)	As Spec.	<b>JIS-C-5201-1 4.8</b> <b>IEC-60115-1 4.8</b> At 25°C/-55°C and 25°C/+125°C, 25°C is the reference temperature
Short Time Overload	$\pm(1.0\%+0.05\Omega)$	<b>JIS-C-5201-1 4.13</b> <b>IEC-60115-1 4.13</b> RCWV*2.5 or Max. Overload Voltage whichever is lower for 5 seconds
Insulation Resistance	$\geq 10G$	<b>JIS-C-5201-1 4.6</b> <b>IEC-60115-1 4.6</b> Max. Overload Voltage for 1 minute
Endurance	$\pm(1.0\%+0.05\Omega)$	<b>JIS-C-5201-1 4.25</b> <b>IEC-60115-1 4.25.1</b> 70 $\pm$ 2°C, RCWV for 1000 hrs with 1.5 hrs "ON" and 0.5 hr "OFF"
Damp Heat with Load	$\pm(0.5\%+0.05\Omega)$	<b>JIS-C-5201-1 4.24</b> <b>IEC-60115-1 4.24</b> 40 $\pm$ 2°C, 90~95% R.H., RCWV for 1000 hrs with 1.5 hrs "ON" and 0.5 hr "OFF"
	<b>Ultra High Power *</b> $\pm(1.0\%+0.05\Omega)$	
Dry Heat	$\pm(0.5\%+0.05\Omega)$	<b>JIS-C-5201-1 4.23</b> <b>IEC-60115-1 4.23.2</b> at +155°C for 1000 hrs

**Pulse Withstanding Chip Resistor**

Item	Requirement	Test Method
Bending Strength	$\pm(1.0\%+0.05\Omega)$	JIS-C-5201-1 4.33 IEC-60115-1 4.33 Bending once for 5 seconds 2010, 2512 sizes: 2mm Other sizes: 3mm
Solderability	95% min. coverage	JIS-C-5201-1 4.17 IEC-60115-1 4.17 245 $\pm$ 5°C for 3 seconds
Resistance to Soldering Heat	$\pm(0.5\%+0.05\Omega)$	JIS-C-5201-1 4.18 IEC-60115-1 4.18 260 $\pm$ 5°C for 10 seconds
Voltage Proof	No breakdown or flashover	JIS-C-5201-1 4.7 IEC-60115-1 4.7 1.42 times Max. Operating Voltage for 1 minute
Leaching	Individual leaching area $\leq$ 5% Total leaching area $\leq$ 10%	JIS-C-5201-1 4.18 IEC-60068-2-58 8.2.1 260 $\pm$ 5°C for 30 seconds
Rapid Change of Temperature	$\pm(0.5\%+0.05\Omega)$	JIS-C-5201-1 4.19 IEC-60115-1 4.19 -55°C to +155°C, 5 cycles

RCWV(Rated Continuous Working Voltage)= $\sqrt{P \cdot R}$  or Max. Operating Voltage whichever is lower.

■Storage Temperature: 15~28°C; Humidity < 80%RH

■Packaging

Reel Specifications & Packaging Quantity

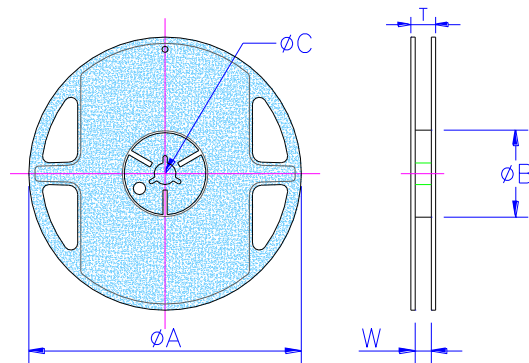

Type	Packaging Quantity		Tape Width	Reel Diameter	øA (mm)	øB (mm)	øC (mm)	W (mm)	T (mm)
PWR02	Paper	10K	8mm	7 inch	178.5 $\pm$ 1.5	60 <sup>+1/-0</sup>	13.0 $\pm$ 0.2	9.0 $\pm$ 0.5	12.5 $\pm$ 0.5
PWR03 PWR05 PWR06 PWR13	Paper	5K	8mm	7 inch	178.5 $\pm$ 1.5	60 <sup>+1/-0</sup>	13.0 $\pm$ 0.2	9.0 $\pm$ 0.5	12.5 $\pm$ 0.5
PWR10 PWR12	Embossed	4K	12mm	7 inch	178.5 $\pm$ 1.5	60 <sup>+1/-0</sup>	13.0 $\pm$ 0.5	13.0 $\pm$ 0.5	15.5 $\pm$ 0.5

Paper Tape Specifications

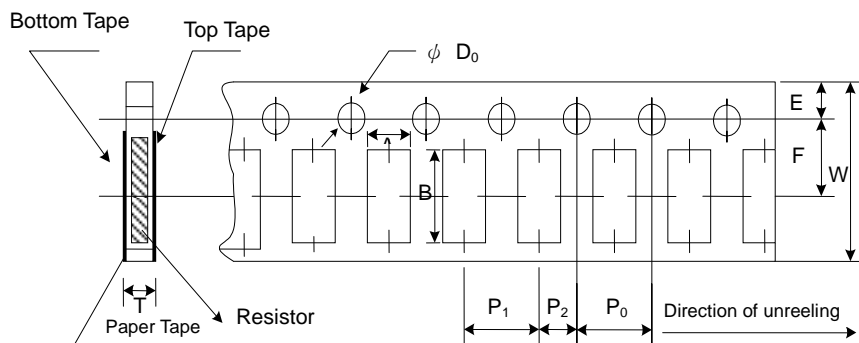

Type	A (mm)	B (mm)	W (mm)	E (mm)	F (mm)	P <sub>0</sub> (mm)	P <sub>1</sub> (mm)	P <sub>2</sub> (mm)	ΦD <sub>0</sub> (mm)	T (mm)
PWR02	0.65±0.10	1.15±0.10	8.0±0.2	1.75±0.1	3.50±0.05	4.00±0.10	2.00±0.05	2.00±0.05	1.50+0.1,-0	0.45±0.1
PWR03	1.10±0.10	1.90±0.1	8.0±0.2	1.75±0.1	3.50±0.05	4.00±0.10	4.00±0.05	2.00±0.05	1.50+0.1,-0	0.70±0.1
PWR05	1.60±0.10	2.40±0.2	8.0±0.2	1.75±0.1	3.50±0.05	4.00±0.10	4.00±0.05	2.00±0.05	1.50+0.1,-0	0.85±0.1
PWR06	1.90±0.10	3.50±0.2	8.0±0.2	1.75±0.1	3.50±0.05	4.00±0.10	4.00±0.05	2.00±0.05	1.50+0.1,-0	0.85±0.1
PWR13	2.90±0.10	3.50±0.2	8.0±0.2	1.75±0.1	3.50±0.05	4.00±0.10	4.00±0.05	2.00±0.05	1.50+0.1,-0	0.85±0.1

**Embossed Plastic Tape Specifications**

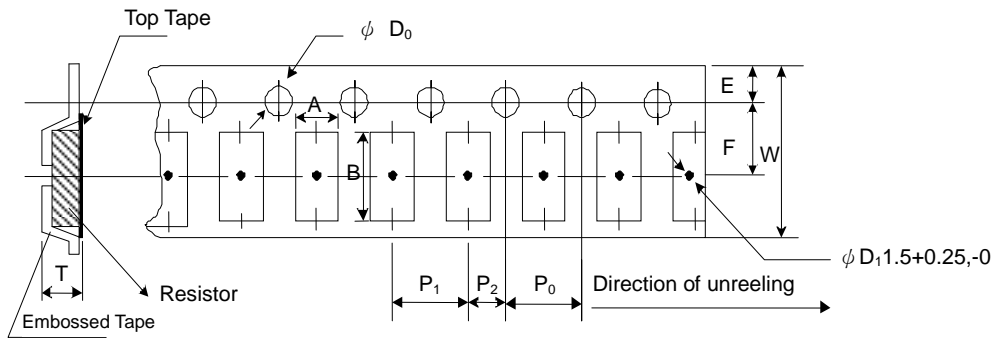

Type	A (mm)	B (mm)	W (mm)	E (mm)	F (mm)	P <sub>0</sub> (mm)	P <sub>1</sub> (mm)	P <sub>2</sub> (mm)	ΦD <sub>0</sub> (mm)	T (mm)
PWR10	2.8±0.10	5.5±0.10	12.0±0.3	1.75±0.1	5.5±0.05	4.00±0.10	4.00±0.1	2.00±0.05	1.50+0.1, -0	1.2 <sup>+0</sup>
PWR12	3.5±0.10	6.7±0.10	12.0±0.3	1.75±0.1	5.5±0.05	4.00±0.10	4.00±0.1	2.00±0.05	1.50+0.1, -0	1.2 <sup>+0</sup>

**■ Marking**

No Marking for 0402

0805~2512 4 digits marking for Example

Resistance	5.6Ω	97.6Ω	100Ω	2.2KΩ	10KΩ	49.9KΩ	100KΩ	1MΩ
marking	5R60	97R6	1000	2201	1002	4992	1003	1004

0603: 3 digits marking in E24

Example: 101=100Ω 102=1KΩ (1<sup>st</sup> and 2<sup>nd</sup> are E24 code and 3<sup>rd</sup> code is multiplier)

E24 code	10	11	12	13	15	16	18	20	22	24	27	30	33	36	39	43	47	51	56	62	68	75	82	91
----------	----	----	----	----	----	----	----	----	----	----	----	----	----	----	----	----	----	----	----	----	----	----	----	----

1% for 0603: 3 digits marking in E96 (E96 series except E24 series)



digits marking for Example: 13C=13K3Ω 68B=4K99Ω 68X=49.9Ω

**Marking Table**

Code	E96	Code	E96	Code	E96	Code	E96				
02	102	28	191	52	340	75	590				
03	105	29	196	53	348	76	604				
04	107	31	205	54	357	77	619				
06	113	32	210	55	365	78	634				
07	115	33	215	56	374	79	649				
08	118	34	221	57	383	80	665				
09	121	35	226	58	392	81	681				
10	124	36	232	59	402	82	698				
11	127	37	237	60	412	83	715				
13	133	38	243	61	422	84	732				
14	137	39	249	62	432	86	768				
15	140	40	255	63	442	87	787				
16	143	41	261	64	453	88	806				
17	147	42	267	65	464	89	825				
19	154	43	274	66	475	90	845				
20	158	44	280	67	487	91	866				
21	162	45	287	68	499	92	887				
22	165	46	294	69	511	93	909				
23	169	47	301	70	523	94	931				
24	174	48	309	71	536	95	953				
25	178	49	316	72	549	96	976				
26	182	50	324	73	562						
27	187	51	332	74	576						
Code	A	B	C	D	E	F	G	X	Y		
Multiplier	10 <sup>0</sup>	10 <sup>1</sup>	10 <sup>2</sup>	10 <sup>3</sup>	10 <sup>4</sup>	10 <sup>5</sup>	10 <sup>6</sup>	10 <sup>-1</sup>	10 <sup>-2</sup>		

**Recommend Land Pattern**

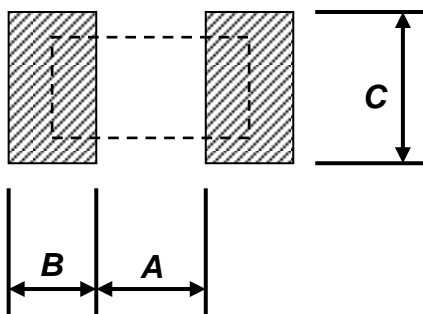

Type	A (mm)	B (mm)	C (mm)
PWR02	0.50	0.45	0.60
PWR03	0.90	0.60	0.90
PWR05	1.20	0.70	1.30
PWR06	2.00	0.90	1.60
PWR13	2.00	0.90	2.80
PWR10	3.80	0.90	2.80
PWR12	4.90	1.00	3.40

**Lightning Surge**

Resistors are tested in accordance with IEC 60115-1 using both 1.2/50us and 10/700 pulse shapes. The limit of acceptance is a shift in resistance of less than 1% from the initial value.

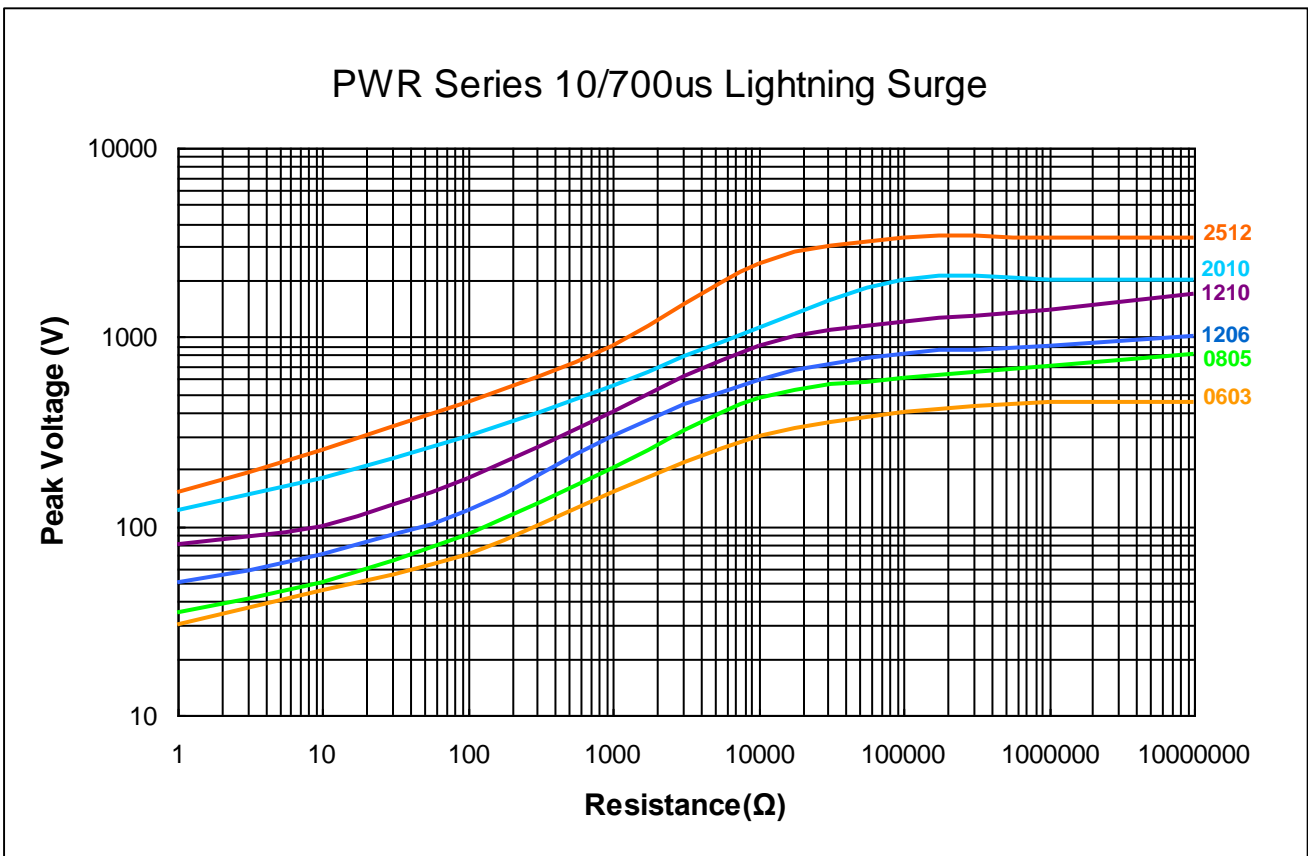
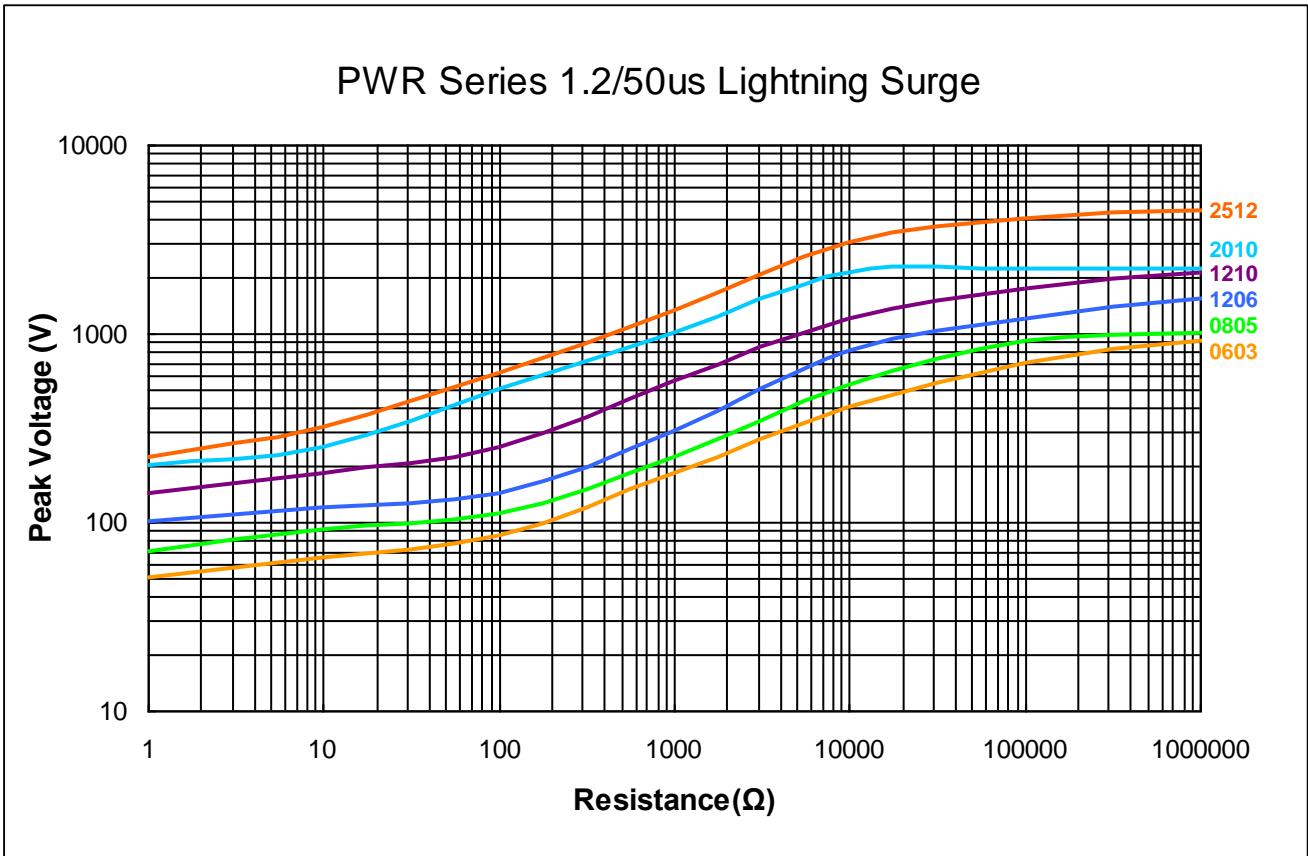



**■ Pulse withstanding capacity**

The limit of acceptance was a shift in resistance of less than 1% from the initial value. The power applied was subject to the restrictions of the maximum permissible impulse voltage graph shown.

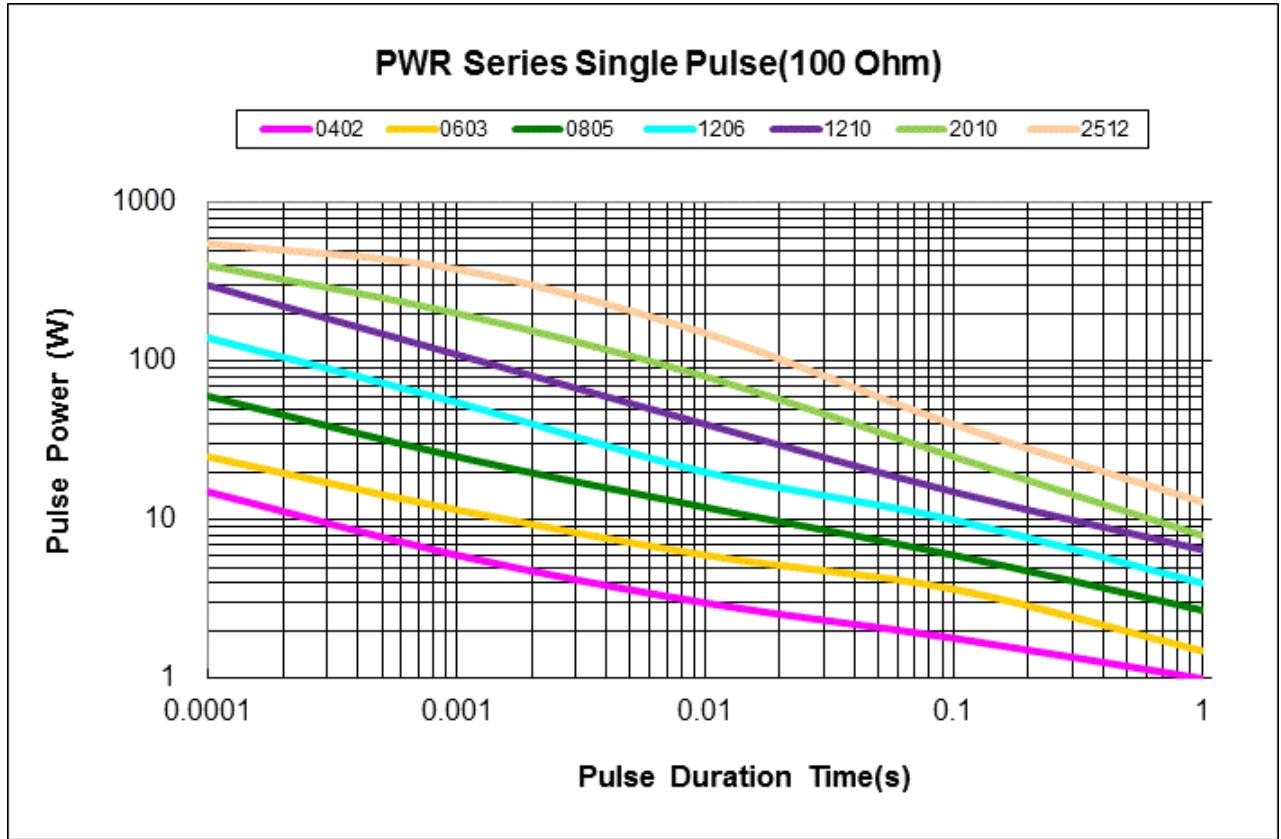

**Continuous Pulse**

The continuous load graph was obtained by applying repetitive rectangular pulses where the pulse period was adjusted so that the average power dissipated in the resistor was equal to its rated power at 70°C. Again the limit of acceptance was a shift in resistance of less than 1% from the initial value.

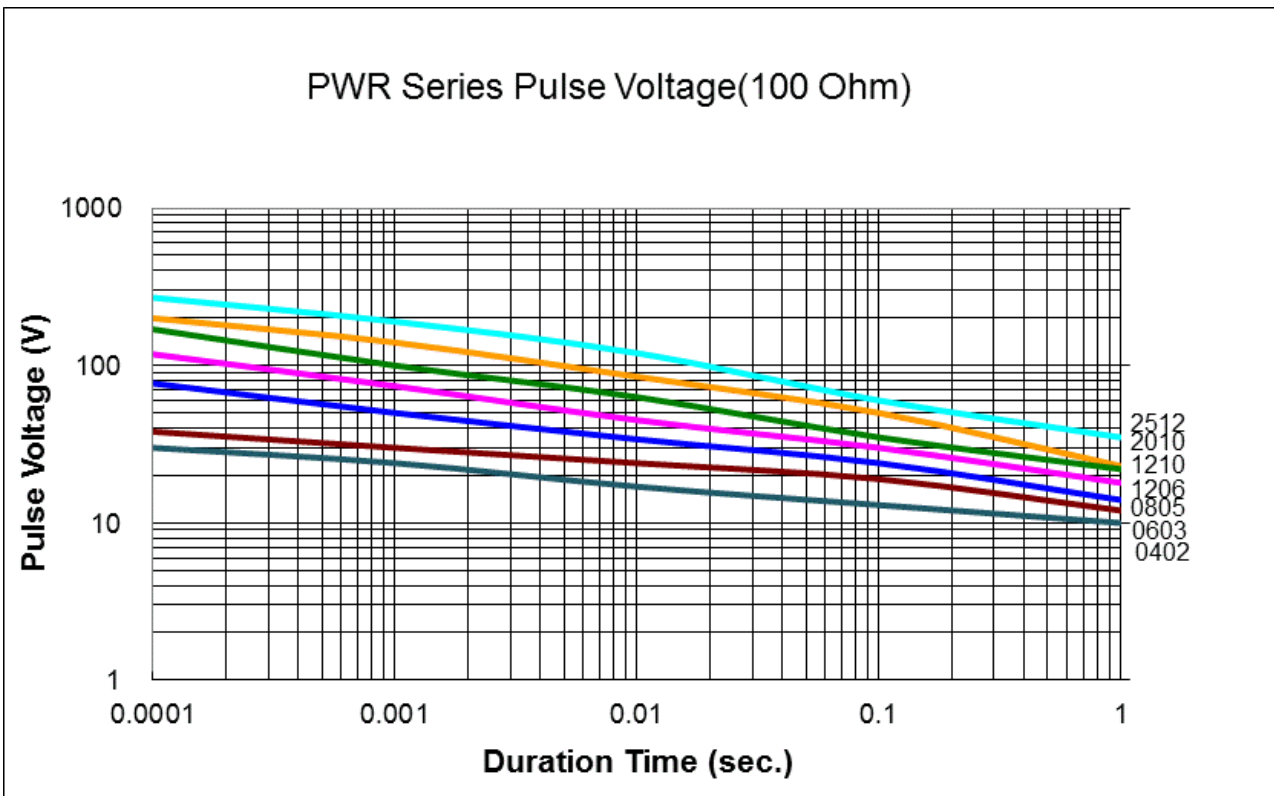
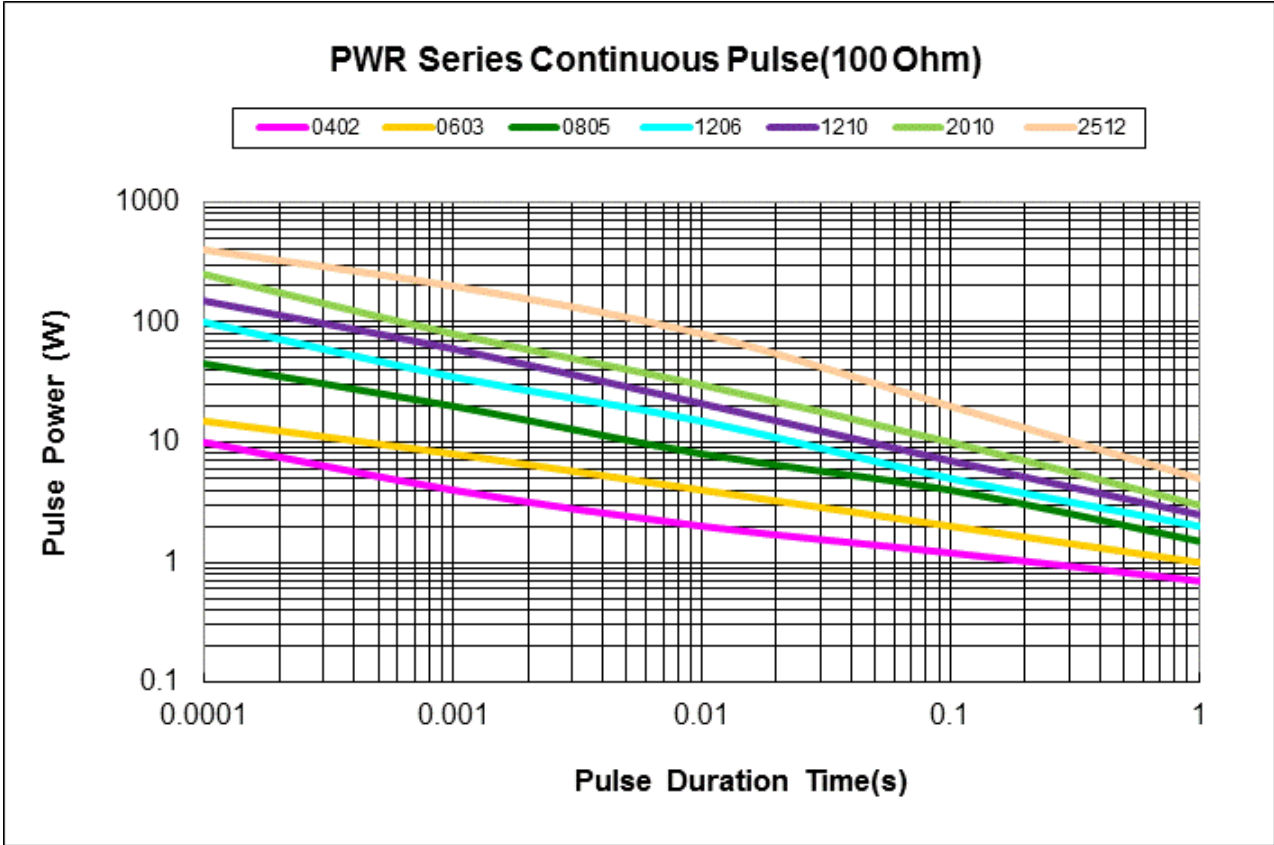

**REVISION HISTORY**

REVISION	DATE	CHANGE NOTIFICATION	DESCRIPTION
Version C	Jun 03, 2014	-	- Environmental Characteristics updated
Version C1	Apr 21, 2016	-	- Features increase AEC-Q200 Compliance
Version C2	Jul 15, 2016	-	- Modify Storage Temperature
Version C3	Oct 13, 2017	-	- Increase High Power Specifications
Version C4	Jul 27, 2018	-	- Increase 0402 size Electrical Specifications - Increase 0805/1206 Ultra High Power Electrical Specifications
Version C5	May 20, 2019	-	- Modify TCR Test description

单击下面可查看定价，库存，交付和生命周期等信息

[>>VIKING\(光颀\)](#)