

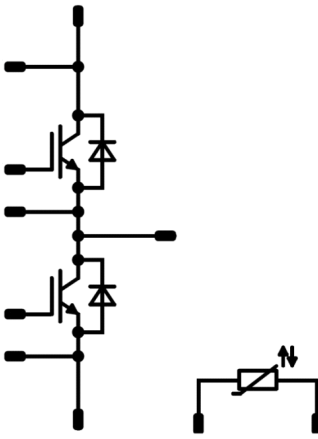

Vincotech

VINcoDUAL E3	1200 V / 300 A
<div style="border: 1px solid black; padding: 5px; margin-bottom: 5px;"> <p style="text-align: center; margin: 0;"><b>Features</b></p> <ul style="list-style-type: none"> <li>IGBT M7 technology with low <math>V_{CEsat}</math> and improved EMC behavior</li> <li>New SoLid Cover Technology for higher reliability</li> <li>Industry standard housing</li> <li>Press-fit pin and pre-applied phase-change</li> <li>Thermal Interface Material available</li> </ul> </div> <div style="border: 1px solid black; padding: 5px; margin-bottom: 5px;"> <p style="text-align: center; margin: 0;"><b>Target applications</b></p> <ul style="list-style-type: none"> <li>Industrial Drives</li> <li>Power Supply</li> <li>UPS</li> </ul> </div> <div style="border: 1px solid black; padding: 5px;"> <p style="text-align: center; margin: 0;"><b>Types</b></p> <ul style="list-style-type: none"> <li>A0-VS122PA300M7-L757F70</li> <li>A0-VP122PA300M7-L757F70T</li> </ul> </div>	<div style="border: 1px solid black; padding: 5px; margin-bottom: 5px;"> <p style="text-align: center; margin: 0;"><b>VINco E3 housing</b></p>  </div> <div style="border: 1px solid black; padding: 5px;"> <p style="text-align: center; margin: 0;"><b>Schematic</b></p>  </div>

## Maximum Ratings

$T_j = 25\text{ °C}$ , unless otherwise specified

Parameter	Symbol	Condition	Value	Unit
<b>Half-Bridge Switch</b>				
Collector-emitter voltage	$V_{CES}$		1200	V
Collector current	$I_C$	$T_j = T_{jmax}$ $T_s = 80\text{ °C}$	315	A
Repetitive peak collector current	$I_{CRM}$	$t_p$ limited by $T_{jmax}$	600	A
Total power dissipation	$P_{tot}$	$T_j = T_{jmax}$ $T_s = 80\text{ °C}$	656	W
Gate-emitter voltage	$V_{GES}$		±20	V
Maximum junction temperature	$T_{jmax}$		175	°C



Vincotech

## Maximum Ratings

$T_j = 25\text{ °C}$ , unless otherwise specified

Parameter	Symbol	Condition	Value	Unit
<b>Half-Bridge Diode</b>				
Peak repetitive reverse voltage	$V_{RRM}$		1200	V
Continuous (direct) forward current	$I_F$	$T_j = T_{jmax}$ $T_s = 80\text{ °C}$	259	A
Repetitive peak forward current	$I_{FRM}$		600	A
Total power dissipation	$P_{tot}$	$T_j = T_{jmax}$ $T_s = 80\text{ °C}$	473	W
Maximum junction temperature	$T_{jmax}$		175	°C

## Module Properties

### Thermal Properties

Storage temperature	$T_{stg}$		-40...+125	°C
Operation temperature under switching condition	$T_{jop}$		-40...( $T_{jmax} - 25$ )	°C

### Isolation Properties

Isolation voltage	$V_{isol}$	DC Test Voltage* $t_p = 2\text{ s}$	6000	V
		AC Voltage $t_p = 1\text{ min}$	2500	V
Creepage distance			18,1	mm
Clearance			16,2	mm
Comparative Tracking Index	CTI		> 200	

\*100 % tested in production



## Characteristic Values

Parameter	Symbol	Conditions					Value			Unit
		$V_{GS}$ [V]	$V_{GE}$ [V]	$V_{DS}$ [V]	$I_D$ [A]	$T_j$ [°C]	Min	Typ	Max	

### Half-Bridge Switch

#### Static

Parameter	Symbol	$V_{GE} = V_{CE}$	$V_{GS}$ [V]	$V_{CE}$ [V]	$I_D$ [A]	$T_j$ [°C]	Min	Typ	Max	Unit
Gate-emitter threshold voltage	$V_{GE(th)}$				0,03	25	5,4	6	6,6	V
Collector-emitter saturation voltage	$V_{CEsat}$		15		300	25 125 150		1,61 1,82 1,91	2,05	V
Collector-emitter cut-off current	$I_{CES}$		0	1200		25			510	μA
Gate-emitter leakage current	$I_{GES}$		20	0		25			1500	nA
Internal gate resistance	$r_g$							none		Ω
Input capacitance	$C_{ies}$							63000		pF
Output capacitance	$C_{oes}$		0	10		25		2100		
Reverse transfer capacitance	$C_{res}$							840		
Gate charge	$Q_g$		±15	600	300	25		3800		nC

#### Thermal

Parameter	Symbol	Material	$\lambda$ [W/mK]	Unit
Thermal resistance junction to sink	$R_{th(j-s)}$	phase-change material	3,4	K/W

#### Dynamic

Parameter	Symbol	$R_{goff} = 1 \Omega$ $R_{gon} = 1 \Omega$	$V_{GS}$ [V]	$V_{CE}$ [V]	$I_D$ [A]	$T_j$ [°C]	Min	Typ	Max	Unit
Turn-on delay time	$t_{d(on)}$					25 125 150		223 226 227		ns
Rise time	$t_r$					25 125 150		17 19 21		
Turn-off delay time	$t_{d(off)}$					25 125 150		254 281 290		
Fall time	$t_f$					25 125 150		76 103 114		
Turn-on energy (per pulse)	$E_{on}$	$Q_{t-FWD} = 34,4 \mu C$ $Q_{t-FWD} = 48,8 \mu C$ $Q_{t-FWD} = 54 \mu C$				25 125 150		6,809 9,370 10,446		mWs
Turn-off energy (per pulse)	$E_{off}$					25 125 150		19,625 27,523 29,844		

\*Including paralel device's leakage current



## Characteristic Values

Parameter	Symbol	Conditions					Value			Unit
		$V_{GE}$ [V]	$V_{CE}$ [V]	$I_C$ [A]	$T_j$ [°C]	Min	Typ	Max		

### Half-Bridge Diode

#### Static

Parameter	Symbol	$V_{GS}$ [V]	$V_{DS}$ [V]	$I_D$ [A]	$I_F$ [A]	$T_j$ [°C]	Min	Typ	Max	Unit
Forward voltage	$V_F$			300		25 125 150		1,82 1,96 1,97	2,15	V
Reverse leakage current	$I_R$		1200			25			180	μA

#### Thermal

Parameter	Symbol	Conditions	Value	Unit
Thermal resistance junction to sink	$R_{th(j-s)}$	phase-change material $\lambda = 3,4$ W/mK	0,20	K/W

#### Dynamic

Parameter	Symbol	$di/dt$	$\pm$	$I_D$ [A]	$I_F$ [A]	$T_j$ [°C]	Min	Typ	Max	Unit
Peak recovery current	$I_{RRM}$			600	307	25 125 150		479 506 515		A
Reverse recovery time	$t_{rr}$			600	307	25 125 150		185 334 369		ns
Recovered charge	$Q_r$	$di/dt = 20088$ A/μs $di/dt = 16728$ A/μs $di/dt = 16130$ A/μs	±15	600	307	25 125 150		34,386 48,784 53,965		μC
Reverse recovered energy	$E_{rec}$			600	307	25 125 150		16,885 24,500 27,559		mWs
Peak rate of fall of recovery current	$(di_{rf}/dt)_{max}$			600	307	25 125 150		10178 9155 8498		A/μs

### Thermistor

Parameter	Symbol	Conditions	$T_j$ [°C]	Min	Typ	Max	Unit
Rated resistance	$R$		25		5		kΩ
Deviation of $R_{100}$	$\Delta_{R/R}$	$R_{100} = 493$ Ω	100	-5		+5	%
Power dissipation	$P$		25		245		mW
Power dissipation constant			25		1,4		mW/K
B-value	$B_{(25/50)}$	Tol. ±2 %	25		3375		K
B-value	$B_{(25/100)}$	Tol. ±2 %	25		3437		K
Vincotech NTC Reference						K	



## Half-Bridge Switch Characteristics

**figure 1. IGBT**

Typical output characteristics

$I_C = f(V_{CE})$

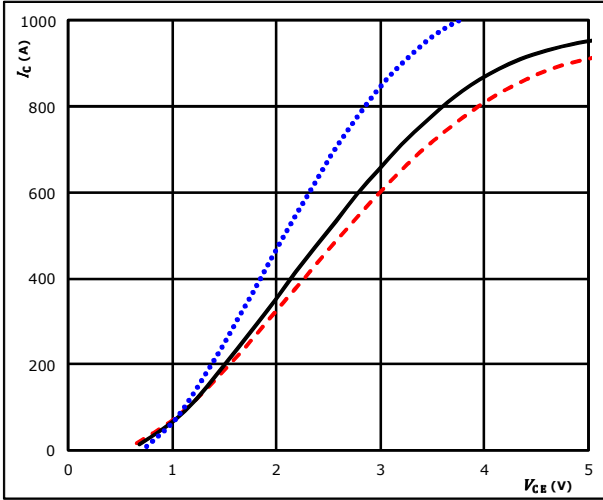

$t_p = 250 \mu s$   $T_j: 25 \text{ }^\circ C$  (blue dotted)  
 $V_{GE} = 15 V$   $T_j: 125 \text{ }^\circ C$  (black solid)  
 $T_j: 150 \text{ }^\circ C$  (red dashed)

**figure 2. IGBT**

Typical output characteristics

$I_C = f(V_{CE})$

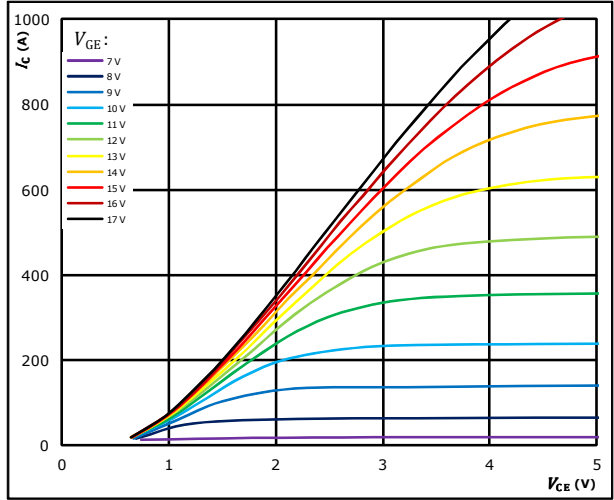

$t_p = 250 \mu s$   
 $T_j = 150 \text{ }^\circ C$   
 $V_{GE}$  from 7 V to 17 V in steps of 1 V

**figure 3. IGBT**

Typical transfer characteristics

$I_C = f(V_{GE})$

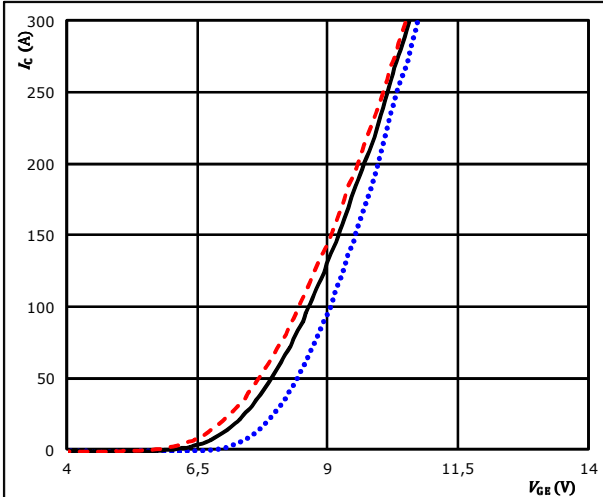

$t_p = 100 \mu s$   $T_j: 25 \text{ }^\circ C$  (blue dotted)  
 $V_{CE} = 10 V$   $T_j: 125 \text{ }^\circ C$  (black solid)  
 $T_j: 150 \text{ }^\circ C$  (red dashed)

**figure 4. IGBT**

Transient thermal impedance as function of pulse duration

$Z_{th(j-s)} = f(t_p)$

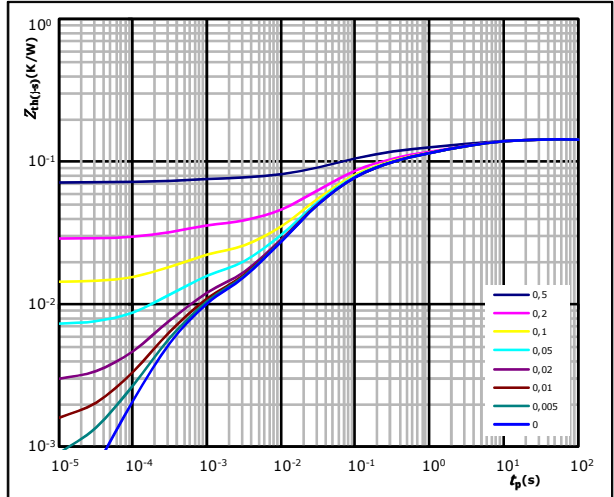

$D = t_p / T$   
 $R_{th(j-s)} = 0,14 \text{ K/W}$

IGBT thermal model values

$R$ (K/W)	$\tau$ (s)
2,06E-02	6,07E+00
2,32E-02	1,29E+00
3,01E-02	2,03E-01
4,46E-02	4,88E-02
1,79E-02	1,30E-02
8,61E-03	4,01E-04



### Half-Bridge Switch Characteristics

**figure 5.** IGBT

Gate voltage vs gate charge

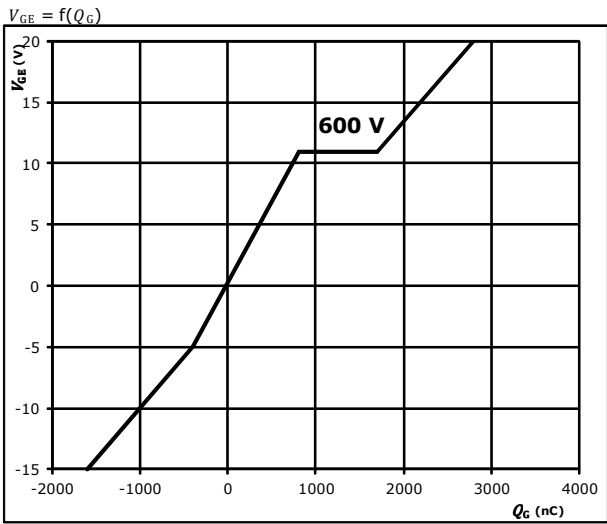

$I_C = 300$  A  
 $V_{GE} = \pm 15$  V  
 $V_{CC} = 600$  V

**figure 6.** IGBT

Safe operating area

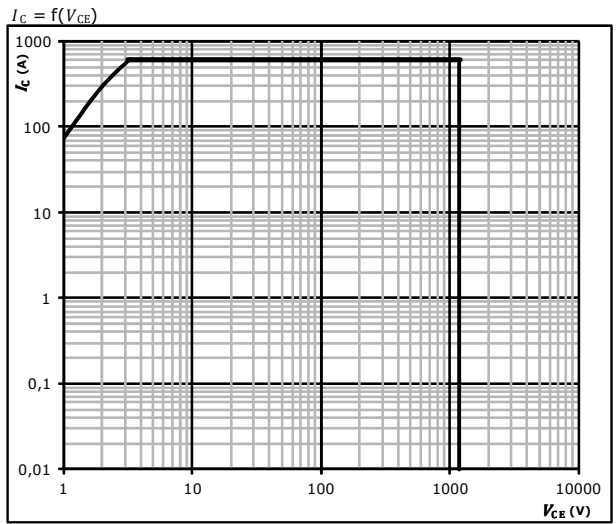

$D =$  single pulse  
 $T_s = 80$  °C  
 $V_{GE} = \pm 15$  V  
 $T_j = T_{jmax}$



## Half-Bridge Diode Characteristics

**figure 1.** FWD

Typical forward characteristics

$$I_F = f(V_F)$$

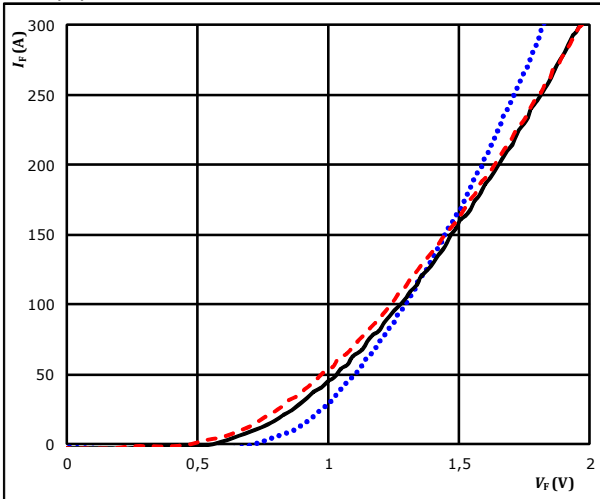

$t_p = 250 \mu s$   
 $T_j$ : 25 °C (blue dotted line)  
 125 °C (black solid line)  
 150 °C (red dashed line)

**figure 2.** FWD

Transient thermal impedance as a function of pulse width

$$Z_{th(j-s)} = f(t_p)$$

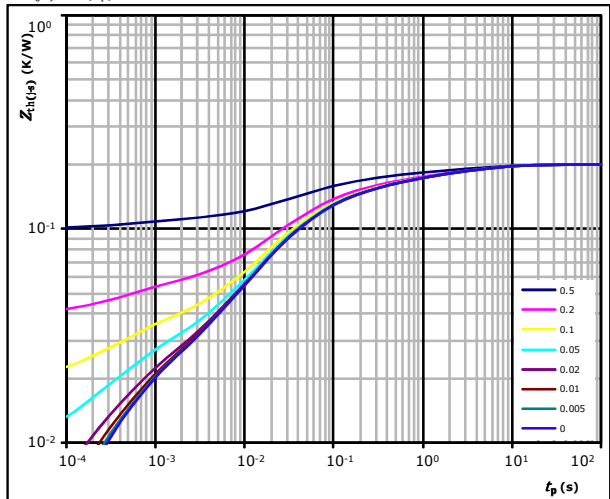

$D = t_p / T$   
 $R_{th(j-s)} = 0,20 \text{ K/W}$

FWD thermal model values

$R$ (K/W)	$\tau$ (s)
2,04E-02	5,59E+00
2,34E-02	1,13E+00
3,69E-02	2,01E-01
6,34E-02	4,50E-02
3,60E-02	1,31E-02
7,69E-03	1,56E-03
1,29E-02	3,42E-04

## Thermistor Characteristics

**figure 1.** Thermistor

Typical NTC characteristic as a function of temperature

$$R = f(T)$$

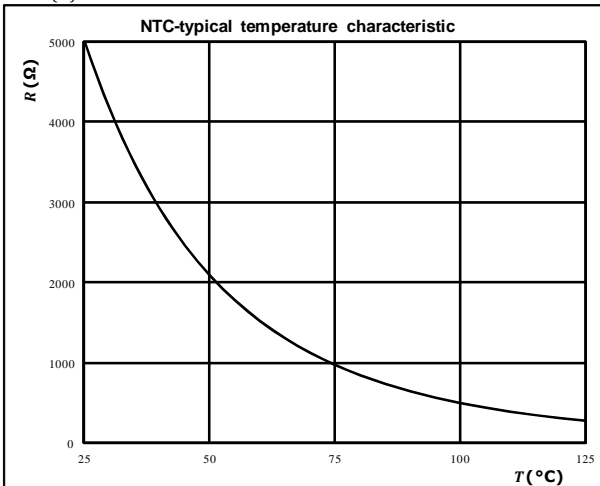



## Half-Bridge Switching Characteristics

**figure 1.** IGBT

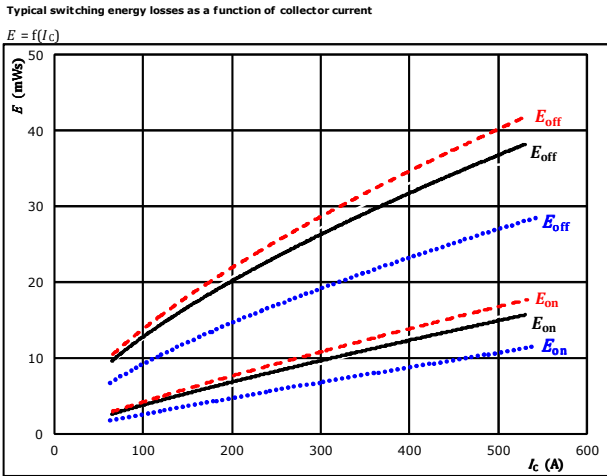

With an inductive load at

$V_{CE} = 600$ V	$T_j: 25$ °C	.....
$V_{GE} = \pm 15$ V	$125$ °C	————
$R_{gon} = 1$ Ω	$150$ °C	- - - -
$R_{goff} = 1$ Ω		

**figure 2.** IGBT

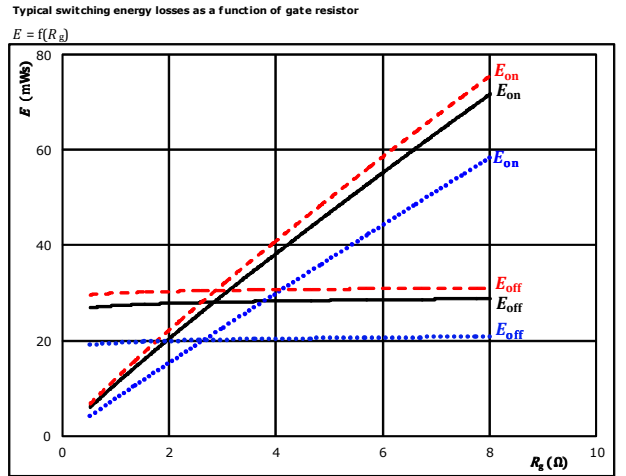

With an inductive load at

$V_{CE} = 600$ V	$T_j: 25$ °C	.....
$V_{GE} = \pm 15$ V	$125$ °C	————
$I_c = 307$ A	$150$ °C	- - - -

**figure 3.** FWD

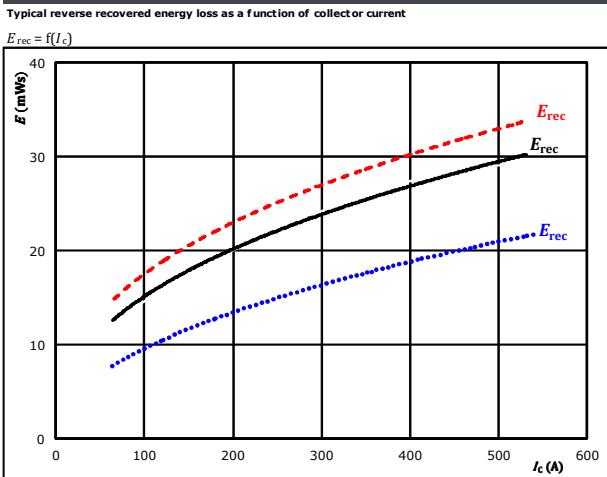

With an inductive load at

$V_{CE} = 600$ V	$T_j: 25$ °C	.....
$V_{GE} = \pm 15$ V	$125$ °C	————
$R_{gon} = 1$ Ω	$150$ °C	- - - -

**figure 4.** FWD

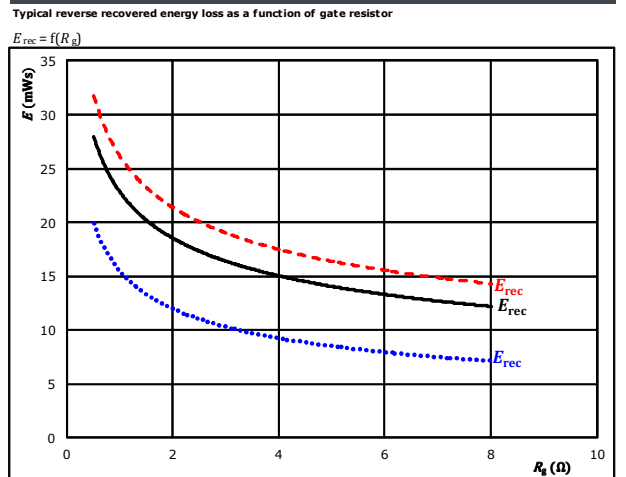

With an inductive load at

$V_{CE} = 600$ V	$T_j: 25$ °C	.....
$V_{GE} = \pm 15$ V	$125$ °C	————
$I_c = 307$ A	$150$ °C	- - - -





Vincotech

## Half-Bridge Switching Characteristics

**figure 5.** IGBT

Typical switching times as a function of collector current

$$t = f(I_c)$$

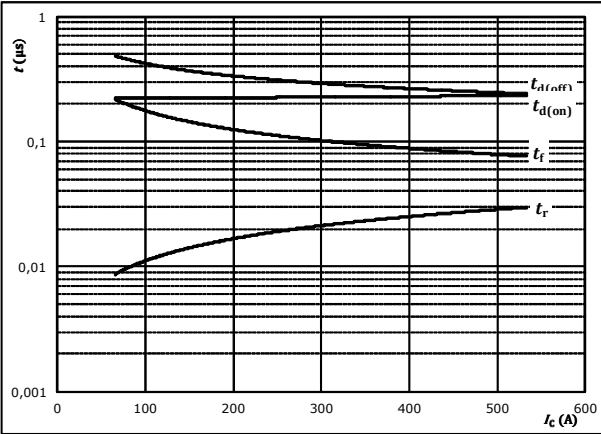

With an inductive load at

$T_j =$	150	°C
$V_{CE} =$	600	V
$V_{GE} =$	±15	V
$R_{gon} =$	1	Ω
$R_{goff} =$	1	Ω

**figure 6.** IGBT

Typical switching times as a function of gate resistor

$$t = f(R_g)$$

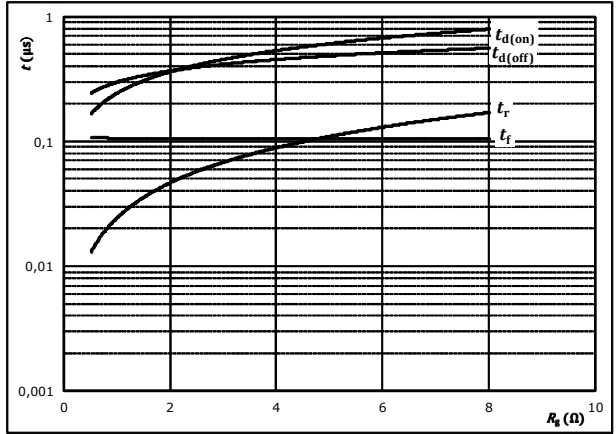

With an inductive load at

$T_j =$	150	°C
$V_{CE} =$	600	V
$V_{GE} =$	±15	V
$I_c =$	307	A

**figure 7.** FWD

Typical reverse recovery time as a function of collector current

$$t_{rr} = f(I_c)$$

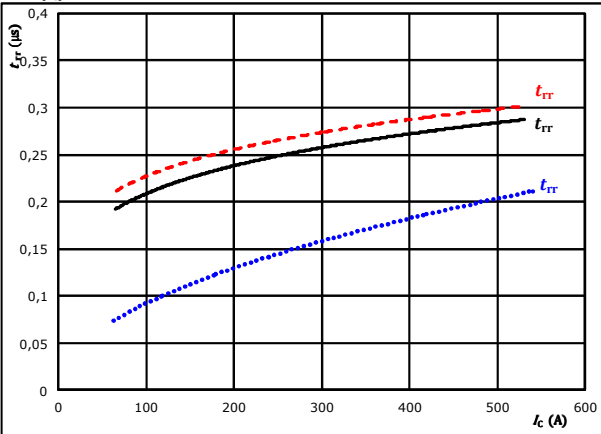

At	$V_{CE} =$	600	V	$T_j:$	25 °C	.....
	$V_{GE} =$	±15	V		125 °C	————
	$R_{gon} =$	1	Ω		150 °C	- - - -

**figure 8.** FWD

Typical reverse recovery time as a function of IGBT turn on gate resistor

$$t_{rr} = f(R_{gon})$$

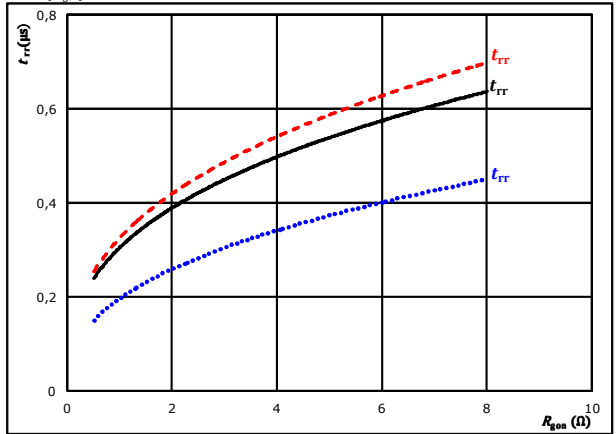

At	$V_{CE} =$	600	V	$T_j:$	25 °C	.....
	$V_{GE} =$	±15	V		125 °C	————
	$I_c =$	307	A		150 °C	- - - -



Vincotech

## Half-Bridge Switching Characteristics

**figure 9.** FWD

Typical recovered charge as a function of collector current

$$Q_r = f(I_c)$$

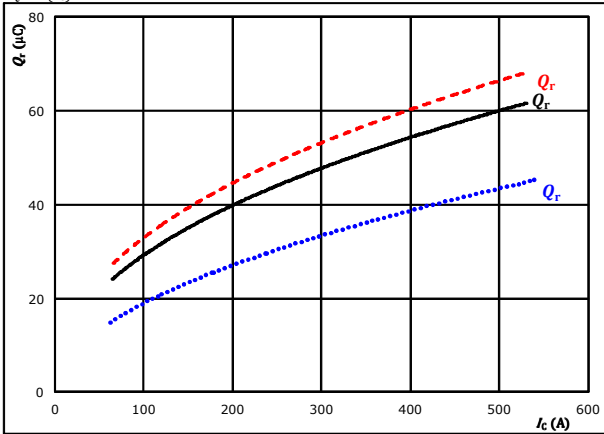

At  $V_{CE} = 600$  V  $T_j = 25$  °C .....  
 $V_{GE} = \pm 15$  V  $T_j = 125$  °C ———  
 $R_{gdn} = 1$  Ω  $T_j = 150$  °C - - - - -

**figure 10.** FWD

Typical recovered charge as a function of IGBT turn on gate resistor

$$Q_r = f(R_{gdn})$$

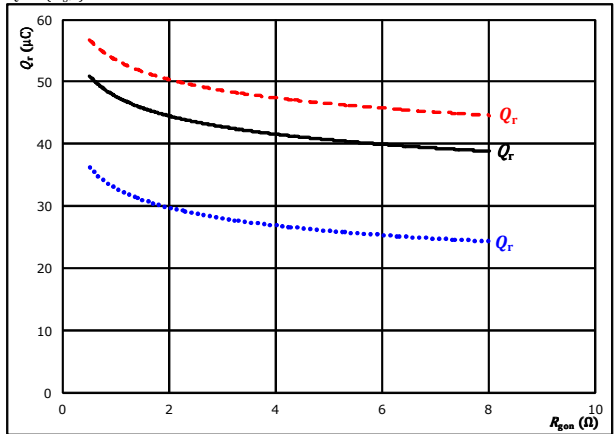

At  $V_{CE} = 600$  V  $T_j = 25$  °C .....  
 $V_{GE} = \pm 15$  V  $T_j = 125$  °C ———  
 $I_c = 307$  A  $T_j = 150$  °C - - - - -

**figure 11.** FWD

Typical peak reverse recovery current as a function of collector current

$$I_{RM} = f(I_c)$$

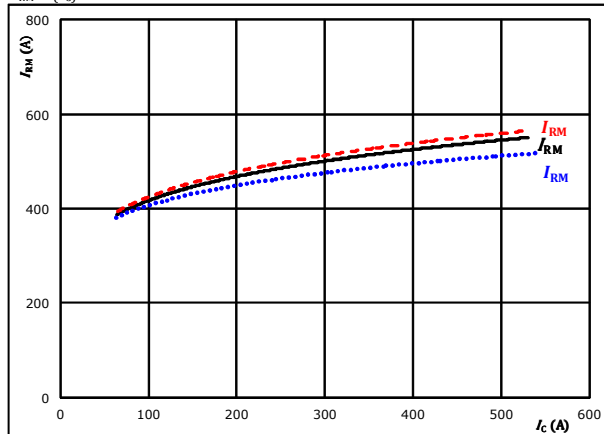

At  $V_{CE} = 600$  V  $T_j = 25$  °C .....  
 $V_{GE} = \pm 15$  V  $T_j = 125$  °C ———  
 $R_{gdn} = 1$  Ω  $T_j = 150$  °C - - - - -

**figure 12.** FWD

Typical peak reverse recovery current as a function of IGBT turn on gate resistor

$$I_{RM} = f(R_{gdn})$$

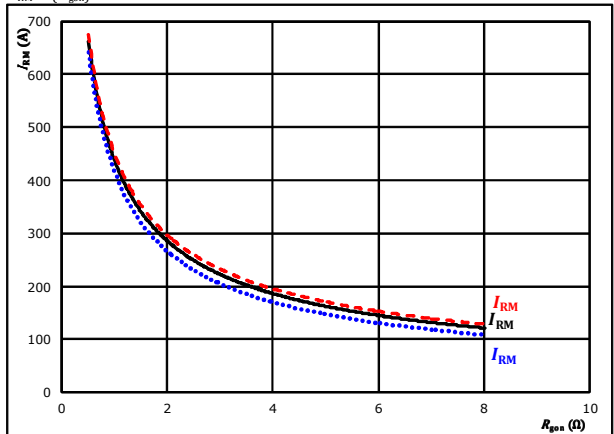

At  $V_{CE} = 600$  V  $T_j = 25$  °C .....  
 $V_{GE} = \pm 15$  V  $T_j = 125$  °C ———  
 $I_c = 307$  A  $T_j = 150$  °C - - - - -



## Half-Bridge Switching Characteristics

**figure 13.** FWD

Typical rate of fall of forward and reverse recovery current as a function of collector current  
 $di_f/dt, di_{rr}/dt = f(I_c)$

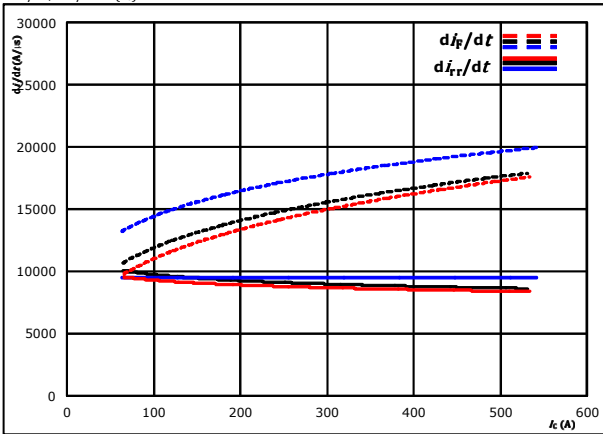

At  $V_{CE} = 600$  V  $T_j = 25$  °C .....  
 $V_{GE} = \pm 15$  V  $T_j = 125$  °C ———  
 $R_{g(on)} = 1$  Ω  $T_j = 150$  °C - - - - -

**figure 14.** FWD

Typical rate of fall of forward and reverse recovery current as a function of IGBT turn on gate resistor  
 $di_f/dt, di_{rr}/dt = f(R_{g(on)})$

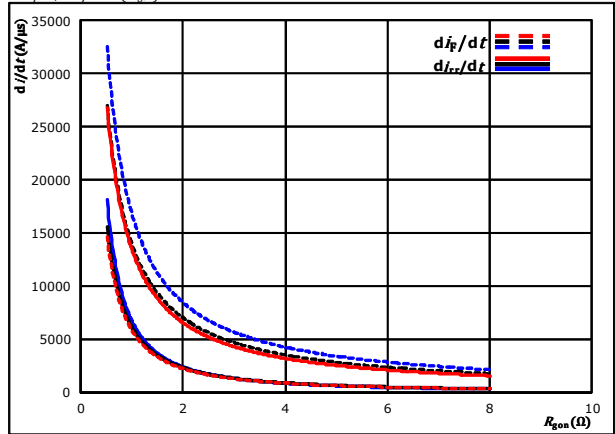

At  $V_{CE} = 600$  V  $T_j = 25$  °C .....  
 $V_{GE} = \pm 15$  V  $T_j = 125$  °C ———  
 $I_c = 307$  A  $T_j = 150$  °C - - - - -

**figure 15.** IGBT

Reverse bias safe operating area  
 $I_c = f(V_{CE})$

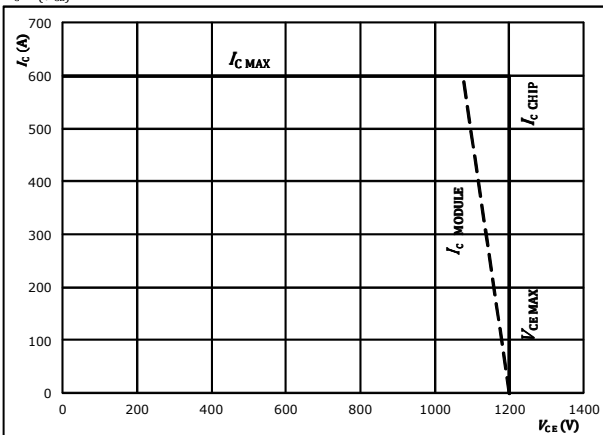

At  $T_j = 175$  °C  
 $R_{g(on)} = 1$  Ω  
 $R_{g(off)} = 1$  Ω



Vincotech

**A0-VS122PA300M7-L757F70**  
**A0-VP122PA300M7-L757F70T**  
 datasheet

## Half-Bridge Switching Definitions

### General conditions

$T_j$	=	125 °C
$R_{gon}$	=	1 $\Omega$
$R_{goff}$	=	1 $\Omega$

**figure 1.** IGBT

Turn-off Switching Waveforms & definition of  $t_{doff}$ ,  $t_{Eoff}$  ( $t_{Eoff}$  = integrating time for Eoff)

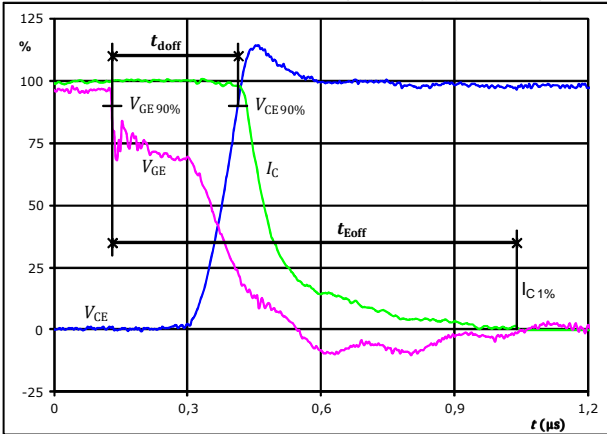

$V_{GE}(0\%) =$	-15	V
$V_{GE}(100\%) =$	15	V
$V_C(100\%) =$	600	V
$I_C(100\%) =$	305	A
$t_{doff} =$	0,281	$\mu s$
$t_{Eoff} =$	0,910	$\mu s$

**figure 2.** IGBT

Turn-on Switching Waveforms & definition of  $t_{don}$ ,  $t_{Eon}$  ( $t_{Eon}$  = integrating time for Eon)

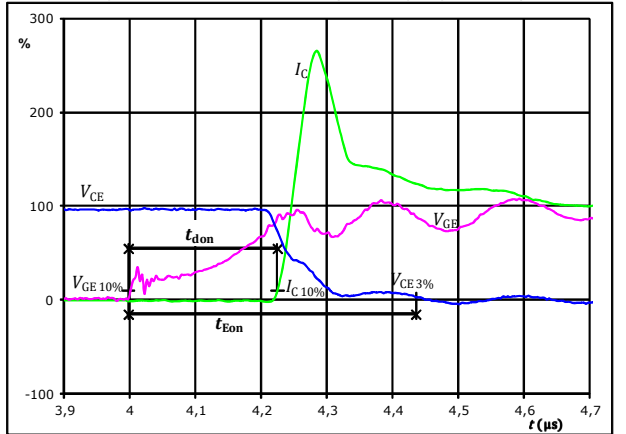

$V_{GE}(0\%) =$	-15	V
$V_{GE}(100\%) =$	15	V
$V_C(100\%) =$	600	V
$I_C(100\%) =$	305	A
$t_{don} =$	0,226	$\mu s$
$t_{Eon} =$	0,437	$\mu s$

**figure 3.** IGBT

Turn-off Switching Waveforms & definition of  $t_f$

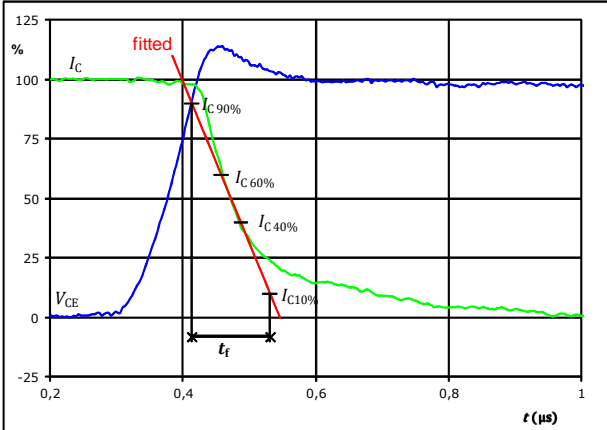

$V_C(100\%) =$	600	V
$I_C(100\%) =$	305	A
$t_f =$	0,103	$\mu s$

**figure 4.** IGBT

Turn-on Switching Waveforms & definition of  $t_r$

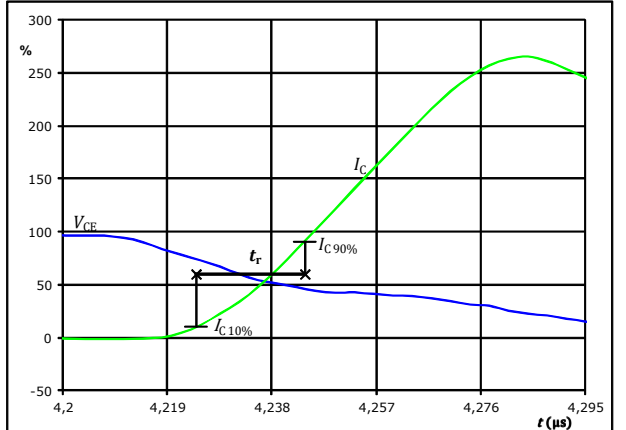

$V_C(100\%) =$	600	V
$I_C(100\%) =$	305	A
$t_r =$	0,019	$\mu s$



Vincotech

## Half-Bridge Switching Characteristics

figure 5. IGBT

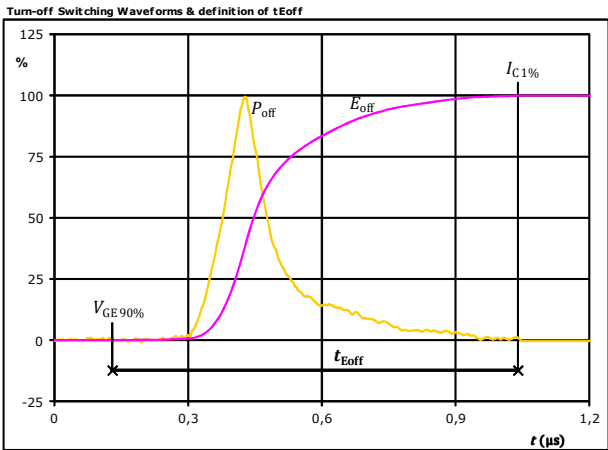

$P_{off}(100\%) =$	183,29	kW
$E_{off}(100\%) =$	27,52	mJ
$t_{Eoff} =$	0,91	$\mu s$

figure 6. IGBT

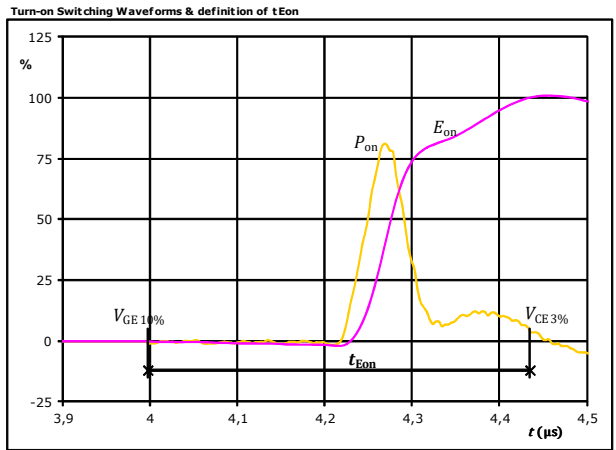

$P_{on}(100\%) =$	183,29	kW
$E_{on}(100\%) =$	9,37	mJ
$t_{Eon} =$	0,44	$\mu s$

figure 7. FWD

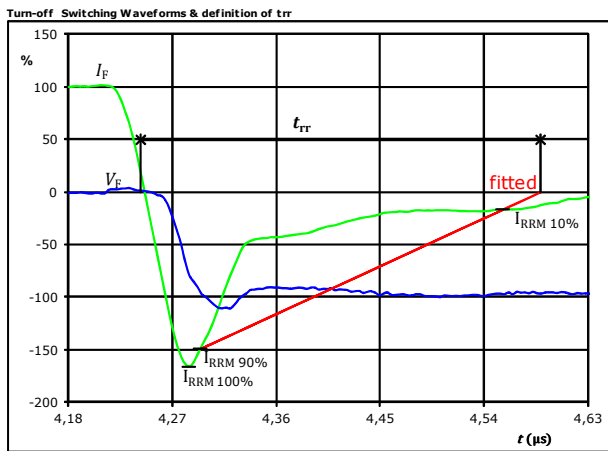

$V_F(100\%) =$	600	V
$I_F(100\%) =$	305	A
$I_{RRM}(100\%) =$	-506	A
$t_{rr} =$	0,334	$\mu s$



Vincotech

## Half-Bridge Switching Characteristics

figure 8. FWD

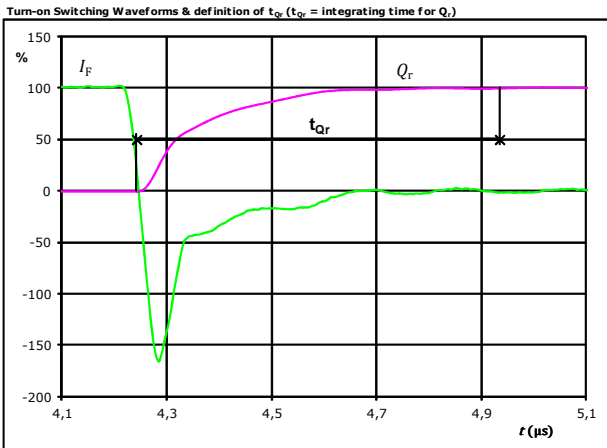

$I_F$ (100%) =	305	A
$Q_r$ (100%) =	48,78	$\mu\text{C}$
$t_{Qr}$ =	0,69	$\mu\text{s}$

figure 9. FWD

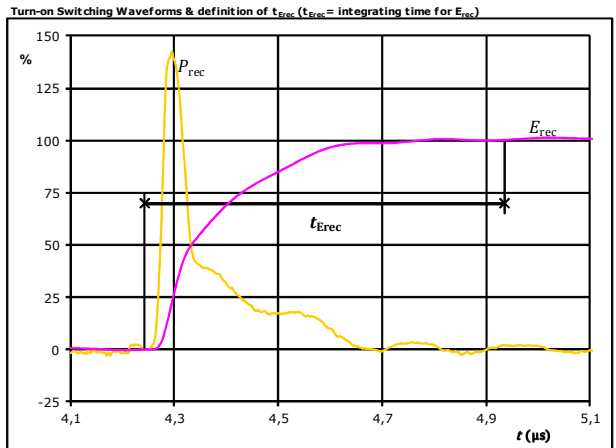

$P_{rec}$ (100%) =	183,29	kW
$E_{rec}$ (100%) =	24,50	mJ
$t_{Erec}$ =	0,69	$\mu\text{s}$



**A0-VS122PA300M7-L757F70**  
**A0-VP122PA300M7-L757F70T**  
 datasheet

Vincotech

Ordering Code & Marking							
Version			Ordering Code				
without thermal paste 17 mm housing with solder pins			A0-VS122PA300M7-L757F70				
with thermal paste 17 mm housing with solder pins			A0-VS122PA300M7-L757F70-/3/				
without thermal paste 17 mm housing with Press-fit			A0-VP122PA300M7-L757F70T				
with thermal paste 17 mm housing with Press-fit pins			A0-VP122PA300M7-L757F70T-/3/				
NN-NNNNNNNNNNNN-TTTTTVV VIN WWYY LLLLL SSSS		<b>Text</b>  <b>Datamatrix</b>	<b>Name</b>	<b>Date code</b>	<b>UL &amp; VIN</b>	<b>Lot</b>	<b>Serial</b>
			NN-NNNNNNNNNNNN-TTTTTVV	WWYY	UL VIN	LLLLL	SSSS
			<b>Type&amp;Ver</b>	<b>Lot number</b>	<b>Serial</b>	<b>Date code</b>	
			TTTTTVV	LLLLL	SSSS	WWYY	

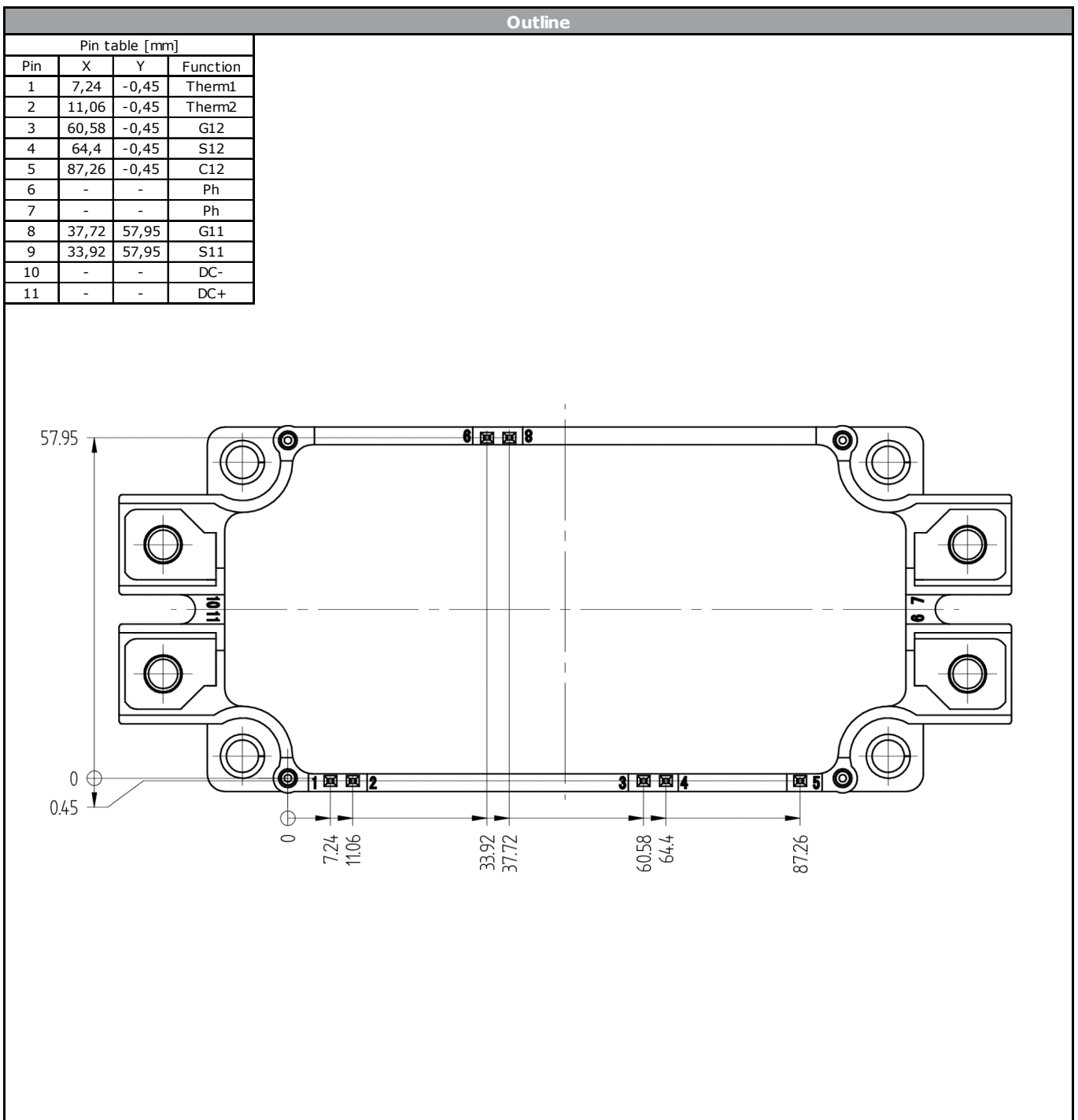



Vincotech

Pinout

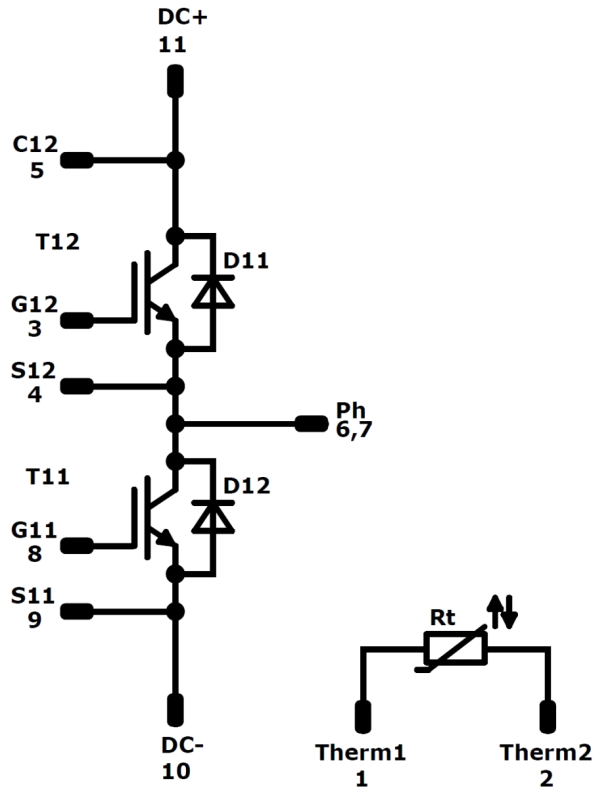

Identification

ID	Component	Voltage	Current	Function	Comment
T11 , T12	IGBT	1200 V	300 A	Half-Bridge Switch	
D11 , D12	FWD	1200 V	300 A	Half-Bridge Diode	
Rt	NTC			Thermistor	





Vincotech

Packaging instruction			
Standard packaging quantity (SPQ) 24	>SPQ	Standard	<SPQ Sample

Handling instruction
Handling instructions for VINco E3 packages see vincotech.com website.

Package data
Package data for VINco E3 packages see vincotech.com website.

UL recognition and file number
This device is certified according to UL 1557 standard, UL file number E192116. For more information see vincotech.com website. 

Document No.:	Date:	Modification:	Pages
A0-VS122PA300M7-L757F70-D2-14	27 Oct. 2017	Correct package data and marking; set $R_{g\text{on}}/R_{g\text{off}}$ to 1 Ohm, adjust collector emitter cut-off current	All

**DISCLAIMER**

The information, specifications, procedures, methods and recommendations herein (together "information") are presented by Vincotech to reader in good faith, are believed to be accurate and reliable, but may well be incomplete and/or not applicable to all conditions or situations that may exist or occur. Vincotech reserves the right to make any changes without further notice to any products to improve reliability, function or design. No representation, guarantee or warranty is made to reader as to the accuracy, reliability or completeness of said information or that the application or use of any of the same will avoid hazards, accidents, losses, damages or injury of any kind to persons or property or that the same will not infringe third parties rights or give desired results. It is reader's sole responsibility to test and determine the suitability of the information and the product for reader's intended use.

**LIFE SUPPORT POLICY**

Vincotech products are not authorised for use as critical components in life support devices or systems without the express written approval of Vincotech.

As used herein:

1. Life support devices or systems are devices or systems which, (a) are intended for surgical implant into the body, or (b) support or sustain life, or (c) whose failure to perform when properly used in accordance with instructions for use provided in labelling can be reasonably expected to result in significant injury to the user.
2. A critical component is any component of a life support device or system whose failure to perform can be reasonably expected to cause the failure of the life support device or system, or to affect its safety or effectiveness.

单击下面可查看定价，库存，交付和生命周期等信息

[>>Vincotech\(威科\)](#)