



flowNPC S3 split

950 V / 600 A

Topology features

- Kelvin Emitter for improved switching performance
- Temperature sensor
- Neutral Point Clamped Topology (I-Type)
- Split topology

Component features

- Low collector emitter saturation voltage
- High speed and smooth switching

Housing features

- Base isolation: AlN
- CTI600 housing material
- Compact, baseplate-less housing
- VINcoPress Technology
- Thermo-mechanical push-and-pull force relief
- Press-fit pin
- Reliable cold welding connection

Target applications

- Solar Inverters

Types

- B0-SL10NIB600S701-PA29F48Z
- B0-SL10NIC600S701-PA39F48Z

flow S3 12 mm housing



PA29F48Z



PA39F48Z

Schematic

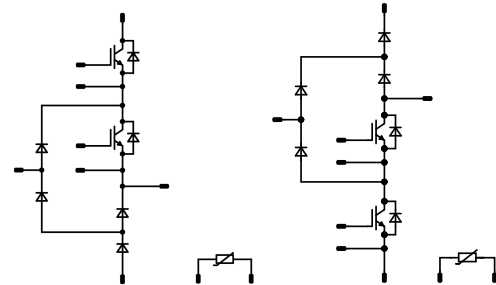

PA29F48Z

PA39F48Z

**Maximum Ratings** $T_j = 25\text{ °C}$, unless otherwise specified

Parameter	Symbol	Conditions	Value	Unit
Buck Switch				
Collector-emitter voltage	V_{CES}		950	V
Collector current (DC current)	I_C	$T_j = T_{jmax}$ $T_s = 80\text{ °C}$	444	A
Repetitive peak collector current	I_{CRM}	t_p limited by T_{jmax}	1200	A
Total power dissipation	P_{tot}	$T_j = T_{jmax}$ $T_s = 80\text{ °C}$	864	W
Gate-emitter voltage	V_{GES}		± 20	V
Maximum junction temperature	T_{jmax}		175	°C
Buck Diode				
Peak repetitive reverse voltage	V_{RRM}		1200	V
Forward current (DC current)	I_F	$T_j = T_{jmax}$ $T_s = 80\text{ °C}$	171	A
Repetitive peak forward current	I_{FRM}	t_p limited by T_{jmax}	728	A
Surge (non-repetitive) forward current	I_{FSM}	Single Half Sine Wave, $t_p = 10\text{ ms}$ $T_j = 25\text{ °C}$	1040	A
Total power dissipation	P_{tot}	$T_j = T_{jmax}$ $T_s = 80\text{ °C}$	432	W
Maximum junction temperature	T_{jmax}		175	°C
Buck Sw. Protection Diode				
Peak repetitive reverse voltage	V_{RRM}		950	V
Forward current (DC current)	I_F	$T_j = T_{jmax}$ $T_s = 80\text{ °C}$	77	A
Total power dissipation	P_{tot}	$T_j = T_{jmax}$ $T_s = 80\text{ °C}$	160	W
Maximum junction temperature	T_{jmax}		175	°C



Maximum Ratings

 $T_j = 25\text{ °C}$, unless otherwise specified

Parameter	Symbol	Conditions	Value	Unit
Boost Switch				
Collector-emitter voltage	V_{CES}		950	V
Collector current (DC current)	I_C	$T_j = T_{jmax}$ $T_s = 80\text{ °C}$	602	A
Repetitive peak collector current	I_{CRM}	i_p limited by T_{jmax}	1200	A
Total power dissipation	P_{tot}	$T_j = T_{jmax}$ $T_s = 80\text{ °C}$	750	W
Gate-emitter voltage	V_{GES}		± 20	V
Maximum junction temperature	T_{jmax}		175	°C
Boost Diode				
Peak repetitive reverse voltage	V_{RRM}		950	V
Forward current (DC current)	I_F	$T_j = T_{jmax}$ $T_s = 80\text{ °C}$	209	A
Total power dissipation	P_{tot}	$T_j = T_{jmax}$ $T_s = 80\text{ °C}$	413	W
Maximum junction temperature	T_{jmax}		175	°C
Boost Sw. Inv. Diode				
Peak repetitive reverse voltage	V_{RRM}		950	V
Forward current (DC current)	I_F	$T_j = T_{jmax}$ $T_s = 80\text{ °C}$	209	A
Total power dissipation	P_{tot}	$T_j = T_{jmax}$ $T_s = 80\text{ °C}$	413	W
Maximum junction temperature	T_{jmax}		175	°C



Maximum Ratings

 $T_j = 25\text{ °C}$, unless otherwise specified

Parameter	Symbol	Conditions	Value	Unit
Boost Sw. Protection Diode				
Peak repetitive reverse voltage	V_{RRM}		950	V
Forward current (DC current)	I_F	$T_j = T_{jmax}$ $T_s = 80\text{ °C}$	77	A
Total power dissipation	P_{tot}	$T_j = T_{jmax}$ $T_s = 80\text{ °C}$	160	W
Maximum junction temperature	T_{jmax}		175	°C

Boost D. Protection Diode

Peak repetitive reverse voltage	V_{RRM}		950	V
Forward current (DC current)	I_F	$T_j = T_{jmax}$ $T_s = 80\text{ °C}$	77	A
Total power dissipation	P_{tot}	$T_j = T_{jmax}$ $T_s = 80\text{ °C}$	160	W
Maximum junction temperature	T_{jmax}		175	°C

Module Properties

Thermal Properties

Storage temperature	T_{stg}		-40...+125	°C
Operation temperature under switching condition	T_{jop}		-40...+($T_{jmax} - 25$)	°C

Isolation Properties

Isolation voltage	V_{isol}	DC Test Voltage* $t_p = 2\text{ s}$	6000	V
Creepage distance		B0-SL10NIB600S701-PA29F48Z	10.55	mm
		B0-SL10NIC600S701-PA39F48Z	9.93	
Clearance		B0-SL10NIB600S701-PA29F48Z	10.55	mm
		B0-SL10NIC600S701-PA39F48Z	8.06	
Comparative Tracking Index	CTI		≥ 600	

*100 % tested in production



Characteristic Values

Parameter	Symbol	Conditions					Values			Unit
		V_{GE} [V] V_{GS} [V]	V_{CE} [V] V_{DS} [V] V_F [V]	I_C [A] I_D [A] I_F [A]	T_j [°C]	Min	Typ	Max		

Buck Switch

Static

Gate-emitter threshold voltage	$V_{GE(th)}$	$V_{CE} = V_{GE}$			0,00975	25	4,35	5,1	5,85	V
Collector-emitter saturation voltage	$V_{CE(sat)}$		15		600	25 125 150		1,82 2,07 2,13	2,25 ⁽¹⁾	V
Collector-emitter cut-off current	I_{CES}		0	950		25			12	μA
Gate-emitter leakage current	I_{GES}		20	0		25			300	nA
Internal gate resistance	r_g							0,5		Ω
Input capacitance	C_{ies}							37800		pF
Output capacitance	C_{oes}	$f = 100$ kHz	0	25		25		810		pF
Reverse transfer capacitance	C_{res}							120		pF
Gate charge	Q_g		15		0	25		1350		nC

Thermal

Thermal resistance junction to sink ⁽²⁾	$R_{th(j-s)}$	$\lambda_{paste} = 4,4$ W/mK (PTM)						0,11		K/W
--	---------------	---------------------------------------	--	--	--	--	--	------	--	-----

Dynamic

Turn-on delay time	$t_{d(on)}$					25 125 150		211,17 214,2 215,37		ns
Rise time	t_r					25 125 150		34,07 36,76 37,93		ns
Turn-off delay time	$t_{d(off)}$					25 125 150		273,37 312,26 322,59		ns
Fall time	t_f					25 125 150		27,27 48,22 57,45		ns
Turn-on energy (per pulse)	E_{on}	$Q_{tFWD} = 1,98$ μC $Q_{tFWD} = 4,21$ μC $Q_{tFWD} = 5,73$ μC				25 125 150		12,45 13,13 13,49		mWs
Turn-off energy (per pulse)	E_{off}					25 125 150		12,41 18,4 20,5		mWs



Vincotech

B0-SL10NIB600S701-PA29F48Z
B0-SL10NIC600S701-PA39F48Z

datasheet

Characteristic Values

Parameter	Symbol	Conditions					Values			Unit
		V_{GE} [V] V_{GS} [V]	V_{CE} [V] V_{DS} [V] V_F [V]	I_C [A] I_D [A] I_F [A]	T_j [°C]	Min	Typ	Max		

Buck Diode

Static

Forward voltage	V_F				160	25 125 150		1,72 2,17 2,32	1,8 ⁽¹⁾	V
Reverse leakage current	I_R	$V_T = 1200$ V				25		280	1600	μA

Thermal

Thermal resistance junction to sink ⁽²⁾	$R_{th(j-s)}$	$\lambda_{paste} = 4,4$ W/mK (PTM)						0,22		K/W
--	---------------	---------------------------------------	--	--	--	--	--	------	--	-----

Dynamic

Peak recovery current	I_{RRM}					25 125 150		63,93 123,98 121,66		A
Reverse recovery time	t_{rr}					25 125 150		46,52 87,75 141,79		ns
Recovered charge	Q_r	$di/dt=5914$ A/μs $di/dt=8412$ A/μs $di/dt=6279$ A/μs	±15	600	355	25 125 150		1,98 4,21 5,73		μC
Reverse recovered energy	E_{rec}					25 125 150		0,665 1,61 2,35		mWs
Peak rate of fall of recovery current	$(di_r/dt)_{max}$					25 125 150		8361,12 4747,29 1605,07		A/μs



Vincotech

B0-SL10NIB600S701-PA29F48Z
B0-SL10NIC600S701-PA39F48Z

datasheet

Characteristic Values

Parameter	Symbol	Conditions					Values			Unit
		V_{GE} [V] V_{GS} [V]	V_{CE} [V] V_{DS} [V] V_F [V]	I_C [A] I_D [A] I_F [A]	T_j [°C]	Min	Typ	Max		

Buck Sw. Protection Diode

Static

Forward voltage	V_F				100	25 125 150	2,1	2,64 2,44 2,36	2,8 ⁽¹⁾	V
Reverse leakage current	I_R	$V_r = 950$ V				25			4	μA

Thermal

Thermal resistance junction to sink ⁽²⁾	$R_{th(j-s)}$	$\lambda_{paste} = 4,4$ W/mK (PTM)						0,59		K/W
--	---------------	---------------------------------------	--	--	--	--	--	------	--	-----



Characteristic Values

Parameter	Symbol	Conditions					Values			Unit
		V_{GE} [V] V_{GS} [V]	V_{CE} [V] V_{DS} [V] V_F [V]	I_C [A] I_D [A] I_F [A]	T_j [°C]	Min	Typ	Max		

Boost Switch

Static

Gate-emitter threshold voltage	$V_{GE(th)}$	$V_{CE} = V_{GE}$			0,00975	25	4,15	4,85	5,65	V
Collector-emitter saturation voltage	$V_{CE(sat)}$		15		600	25 125 150		1,21 1,23 1,24	1,4 ⁽¹⁾	V
Collector-emitter cut-off current	I_{CES}		0	950		25			12	μA
Gate-emitter leakage current	I_{GES}		20	0		25			300	nA
Internal gate resistance	r_g							0,5		Ω
Input capacitance	C_{ies}							73800		pF
Output capacitance	C_{oes}	$f = 100$ kHz	0	25		25		795		pF
Reverse transfer capacitance	C_{res}							330		pF
Gate charge	Q_g		15		0	25		6150		nC

Thermal

Thermal resistance junction to sink ⁽²⁾	$R_{th(j-s)}$	$\lambda_{paste} = 4,4$ W/mK (PTM)						0,13		K/W
--	---------------	---------------------------------------	--	--	--	--	--	------	--	-----

Dynamic

Turn-on delay time	$t_{d(on)}$					25 125 150		488,96 493,44 498,24		ns
Rise time	t_r					25 125 150		50,24 54,4 56		ns
Turn-off delay time	$t_{d(off)}$					25 125 150		395,52 447,68 460,8		ns
Fall time	t_f					25 125 150		250,52 341,62 358,11		ns
Turn-on energy (per pulse)	E_{on}	$Q_{tFWD} = 10,1$ μC $Q_{tFWD} = 24$ μC $Q_{tFWD} = 29,02$ μC				25 125 150		23,23 27,36 29,06		mWs
Turn-off energy (per pulse)	E_{off}					25 125 150		78,24 106,17 113,82		mWs



Characteristic Values

Parameter	Symbol	Conditions					Values			Unit
		V_{GE} [V] V_{GS} [V]	V_{CE} [V] V_{DS} [V] V_F [V]	I_C [A] I_D [A] I_F [A]	T_j [°C]	Min	Typ	Max		
Boost Diode										
Static										
Forward voltage	V_F				300	25 125 150	2,1	2,59 2,43 2,37	2,8 ⁽¹⁾	V
Reverse leakage current	I_R	$V_T = 950$ V				25			12	μA
Thermal										
Thermal resistance junction to sink ⁽²⁾	$R_{th(j-s)}$	$\lambda_{paste} = 4,4$ W/mK (PTM)						0,23		K/W
Dynamic										
Peak recovery current	I_{RRM}					25 125 150		195,57 279,82 299,08		A
Reverse recovery time	t_{rr}					25 125 150		145,91 218,84 244,17		ns
Recovered charge	Q_r	$di/dt=10313$ A/μs $di/dt=9888$ A/μs $di/dt=9489$ A/μs	±15	600	600	25 125 150		10,1 24 29,02		μC
Reverse recovered energy	E_{rec}					25 125 150		2,99 8,09 9,95		mWs
Peak rate of fall of recovery current	$(di_r/dt)_{max}$					25 125 150		8181 4351 4085		A/μs



Characteristic Values

Parameter	Symbol	Conditions					Values			Unit
		V_{GE} [V] V_{GS} [V]	V_{CE} [V] V_{DS} [V] V_F [V]	I_C [A] I_D [A] I_F [A]	T_j [°C]	Min	Typ	Max		

Boost Sw. Inv. Diode

Static

Forward voltage	V_F				300	25 125 150	2,1	2,59 2,43 2,37	2,8 ⁽¹⁾	V
Reverse leakage current	I_R	$V_r = 950$ V				25			12	μA

Thermal

Thermal resistance junction to sink ⁽²⁾	$R_{th(j-s)}$	$\lambda_{paste} = 4,4$ W/mK (PTM)						0,23		K/W
--	---------------	------------------------------------	--	--	--	--	--	------	--	-----

Boost Sw. Protection Diode

Static

Forward voltage	V_F				100	25 125 150	2,1	2,64 2,44 2,36	2,8 ⁽¹⁾	V
Reverse leakage current	I_R	$V_r = 950$ V				25			4	μA

Thermal

Thermal resistance junction to sink ⁽²⁾	$R_{th(j-s)}$	$\lambda_{paste} = 4,4$ W/mK (PTM)						0,59		K/W
--	---------------	------------------------------------	--	--	--	--	--	------	--	-----

Boost D. Protection Diode

Static

Forward voltage	V_F				100	25 125 150	2,1	2,64 2,44 2,36	2,8 ⁽¹⁾	V
Reverse leakage current	I_R	$V_r = 950$ V				25			4	μA

Thermal

Thermal resistance junction to sink ⁽²⁾	$R_{th(j-s)}$	$\lambda_{paste} = 4,4$ W/mK (PTM)						0,59		K/W
--	---------------	------------------------------------	--	--	--	--	--	------	--	-----

**Characteristic Values**

Parameter	Symbol	Conditions					Values			Unit
		V_{GE} [V] V_{GS} [V]	V_{CE} [V] V_{DS} [V] V_F [V]	I_C [A] I_D [A] I_F [A]	T_j [°C]	Min	Typ	Max		

Thermistor**Static**

Rated resistance	R				25		22		kΩ
Deviation of R_{100}	$A_{R/R}$	$R_{100} = 1484 \Omega$			100	-5		5	%
Power dissipation	P						5		mW
Power dissipation constant	d				25		1,5		mW/K
B-value	$B_{(25/50)}$	Tol. $\pm 1 \%$					3962		K
B-value	$B_{(25/100)}$	Tol. $\pm 1 \%$					4000		K
Vincotech Thermistor Reference								I	

⁽¹⁾ Value at chip level⁽²⁾ Only valid with pre-applied Vincotech thermal interface material.



Buck Switch Characteristics

figure 1. IGBT

Typical output characteristics

$$I_C = f(V_{CE})$$

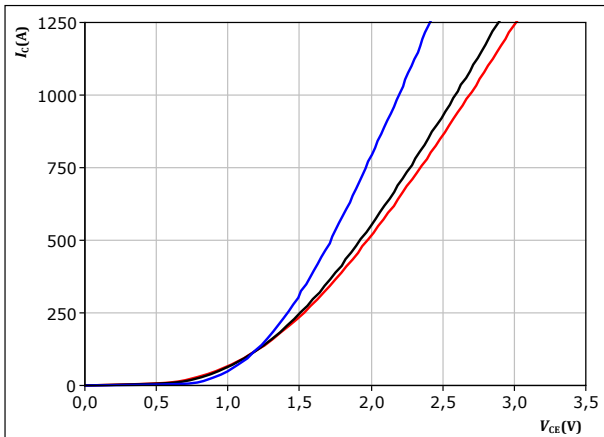

$t_p = 250 \mu s$
 $V_{GE} = 15 V$

T_j : — 25 °C
 — 125 °C
 — 150 °C

figure 2. IGBT

Typical output characteristics

$$I_C = f(V_{CE})$$

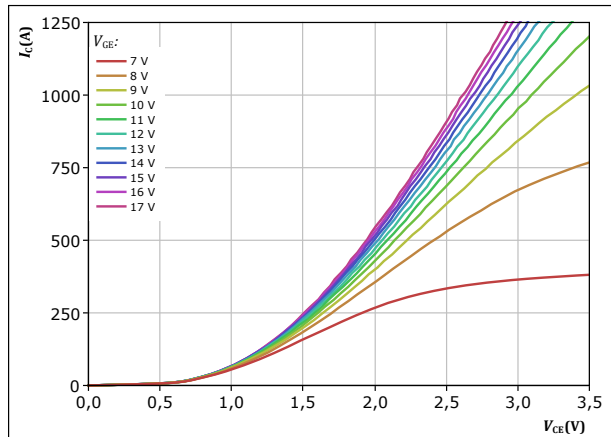

$t_p = 250 \mu s$
 $T_j = 150 \text{ °C}$
 V_{GE} from 7 V to 17 V in steps of 1 V

figure 3. IGBT

Typical transfer characteristics

$$I_C = f(V_{GE})$$

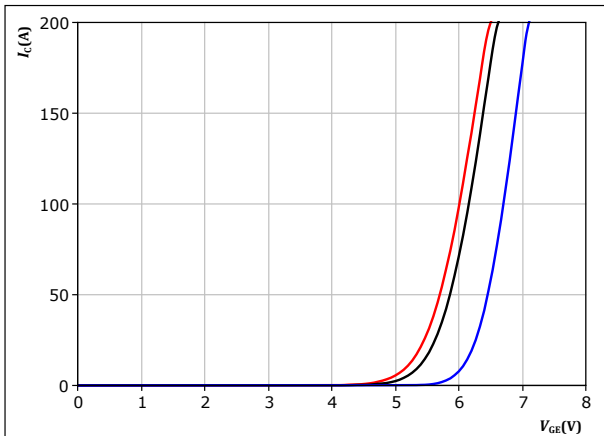

$t_p = 250 \mu s$
 $V_{CE} = 24 V$

T_j : — 25 °C
 — 125 °C
 — 150 °C

figure 4. IGBT

Transient thermal impedance as a function of pulse width

$$Z_{th(j-s)} = f(t_p)$$

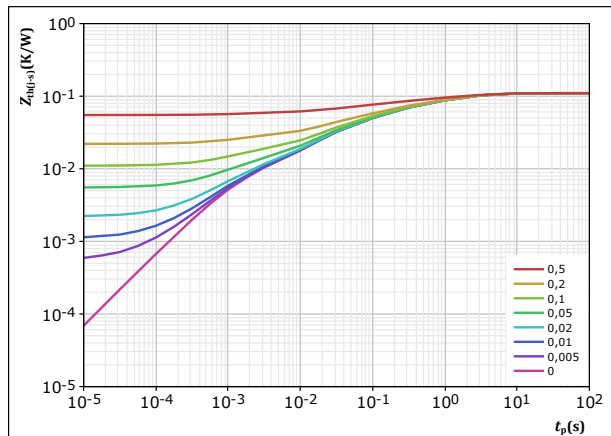

$D = t_p / T$
 $R_{th(j-s)} = 0,11 \text{ K/W}$

IGBT thermal model values

R (K/W)	τ (s)
1,72E-02	3,12E+00
2,61E-02	9,92E-01
3,34E-02	1,78E-01
2,60E-02	2,52E-02
7,27E-03	1,28E-03



Buck Switch Characteristics

figure 5. IGBT

Safe operating area

$$I_C = f(V_{CE})$$

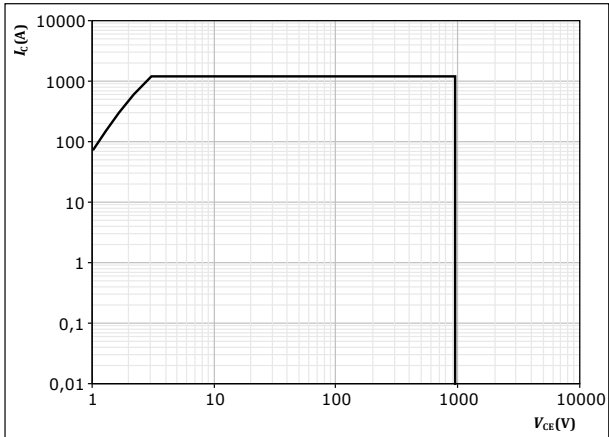

$D =$ single pulse

$T_s = 80$ °C

$V_{CE} = 15$ V

$T_j = T_{jmax}$



Buck Diode Characteristics

figure 6. FWD

Typical forward characteristics

$$I_F = f(V_F)$$

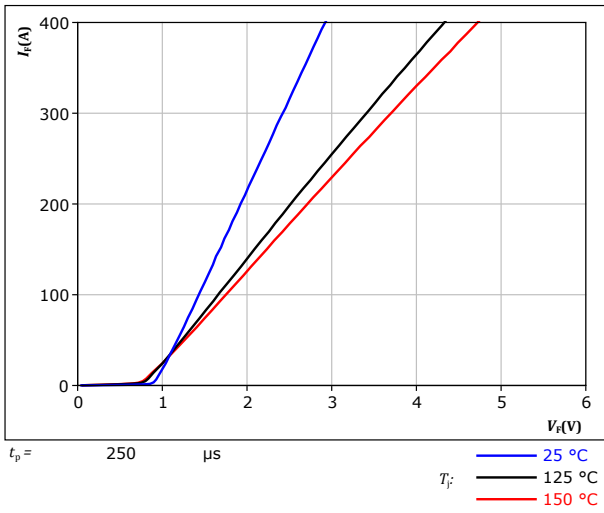
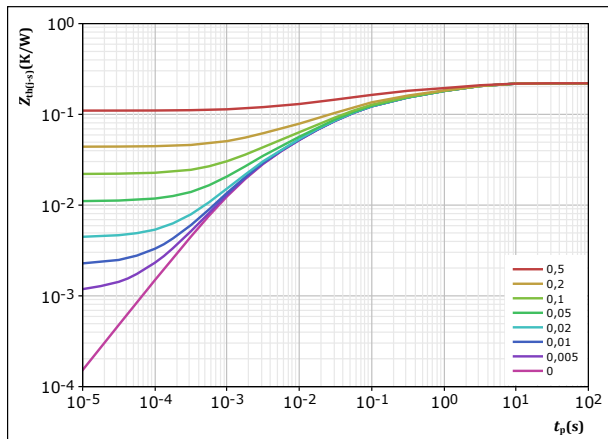

figure 7. FWD

Transient thermal impedance as a function of pulse width

$$Z_{th(j-s)} = f(t_p)$$



$D = t_p / T$

$R_{th(j-s)} = 0,22 \text{ K/W}$

FWD thermal model values

$R \text{ (K/W)}$	$\tau \text{ (s)}$
3,69E-02	3,31E+00
5,12E-02	6,84E-01
7,45E-02	6,90E-02
3,95E-02	1,11E-02
1,79E-02	1,70E-03



Buck Sw. Protection Diode Characteristics

figure 8. FWD

Typical forward characteristics

$$I_F = f(V_F)$$

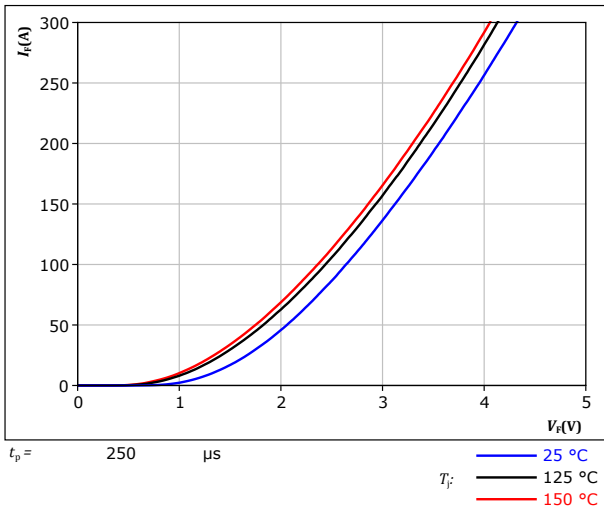
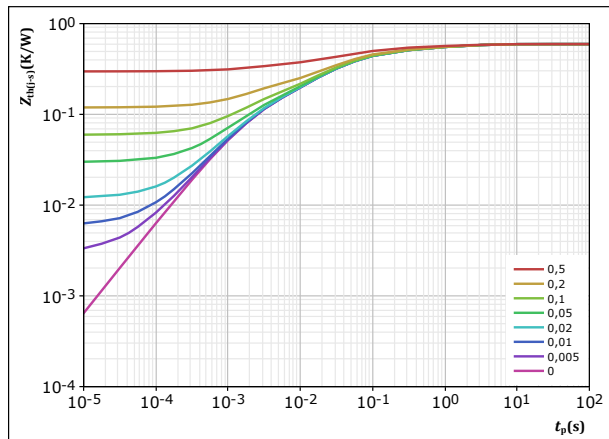

figure 9. FWD

Transient thermal impedance as a function of pulse width

$$Z_{th(j-s)} = f(t_p)$$



$D =$	t_p / T	
$R_{th(j-s)} =$	0,594	K/W
FWD thermal model values		
R (K/W)	τ (s)	
5,02E-02	2,46E+00	
7,95E-02	4,43E-01	
2,28E-01	5,90E-02	
1,50E-01	1,50E-02	
8,75E-02	1,73E-03	



Boost Switch Characteristics

figure 10. IGBT

Typical output characteristics

$$I_C = f(V_{CE})$$

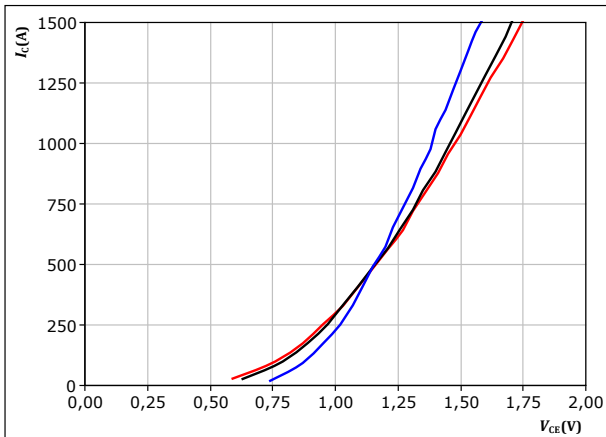

$t_p = 250 \mu\text{s}$
 $V_{GE} = 15 \text{ V}$
 $T_j:$ 25 °C (blue), 125 °C (black), 150 °C (red)

figure 11. IGBT

Typical output characteristics

$$I_C = f(V_{CE})$$

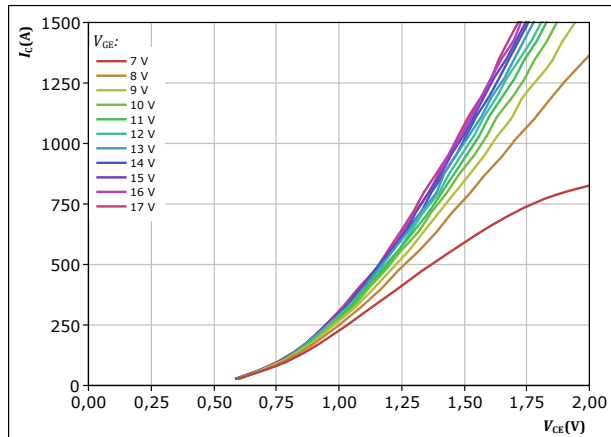

$t_p = 250 \mu\text{s}$
 $T_j = 150 \text{ °C}$
 V_{GE} from 7 V to 17 V in steps of 1 V

figure 12. IGBT

Typical transfer characteristics

$$I_C = f(V_{GE})$$

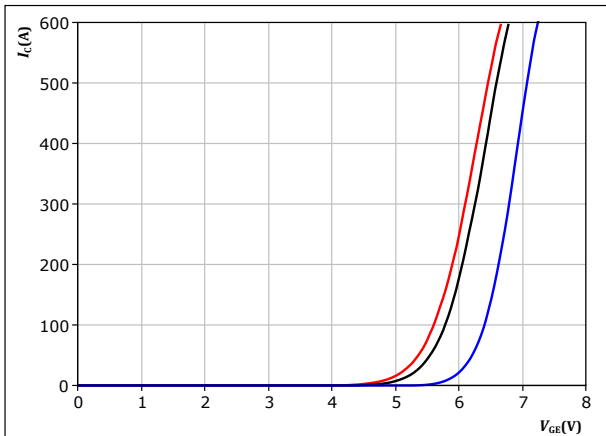

$t_p = 250 \mu\text{s}$
 $V_{CE} = 10 \text{ V}$
 $T_j:$ 25 °C (blue), 125 °C (black), 150 °C (red)

figure 13. IGBT

Transient thermal impedance as a function of pulse width

$$Z_{th(j-s)} = f(t_p)$$

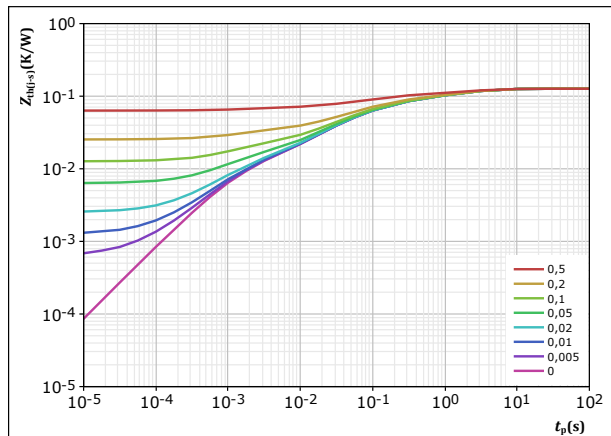

$D = t_p / T$
 $R_{th(j-s)} = 0,127 \text{ K/W}$
 IGBT thermal model values

R (K/W)	τ (s)
2,24E-02	3,16E+00
3,10E-02	7,01E-01
4,64E-02	8,63E-02
1,79E-02	1,89E-02
9,01E-03	1,26E-03



Boost Switch Characteristics

figure 14. IGBT

Safe operating area

$$I_C = f(V_{CE})$$

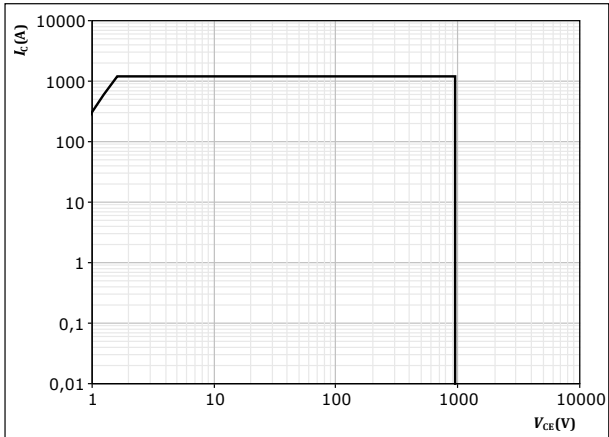

$D =$ single pulse
 $T_s = 80 \text{ } ^\circ\text{C}$
 $V_{CE} = 15 \text{ V}$
 $T_j = T_{jmax}$



Boost Diode Characteristics

figure 15. FWD

Typical forward characteristics

$$I_F = f(V_F)$$

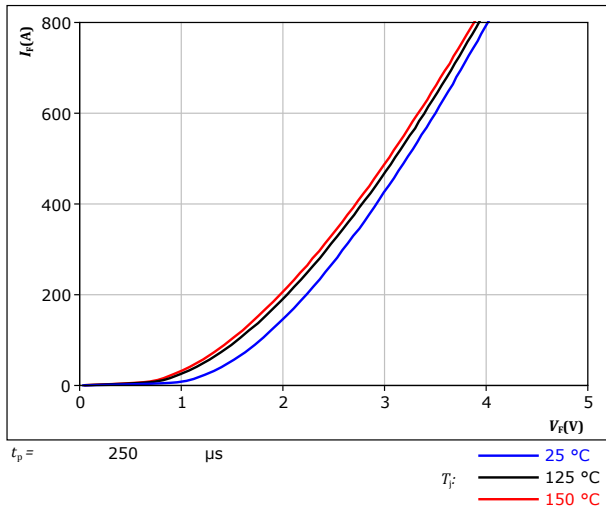
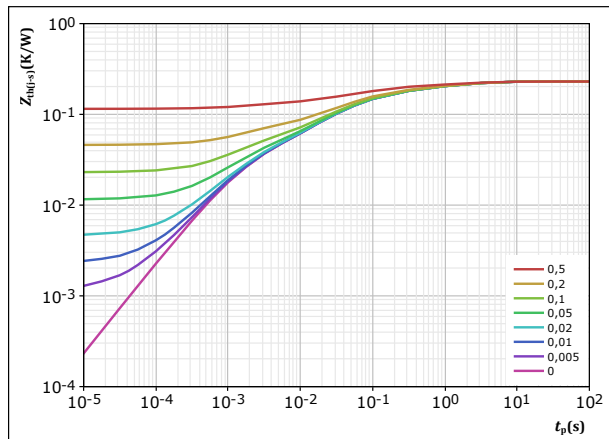

figure 16. FWD

Transient thermal impedance as a function of pulse width

$$Z_{th(j-s)} = f(t_p)$$



$D = t_p / T$
 $R_{th(j-s)} = 0,23$ K/W
 FWD thermal model values

R (K/W)	τ (s)
2,56E-02	2,90E+00
4,35E-02	5,53E-01
9,09E-02	6,81E-02
4,34E-02	1,43E-02
2,66E-02	1,41E-03



Boost Sw. Inv. Diode Characteristics

figure 17. FWD

Typical forward characteristics

$$I_F = f(V_F)$$

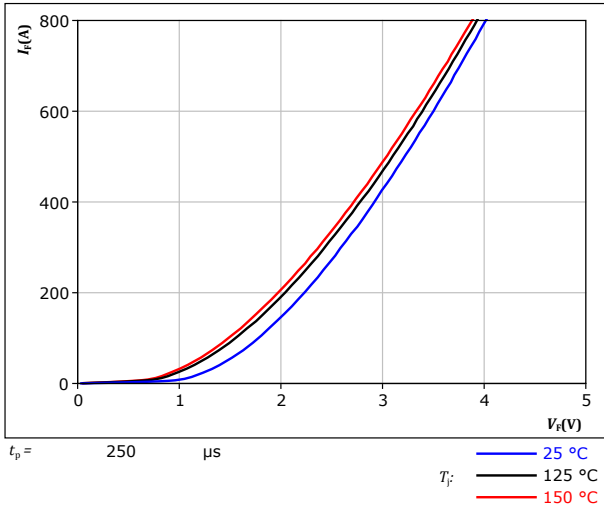
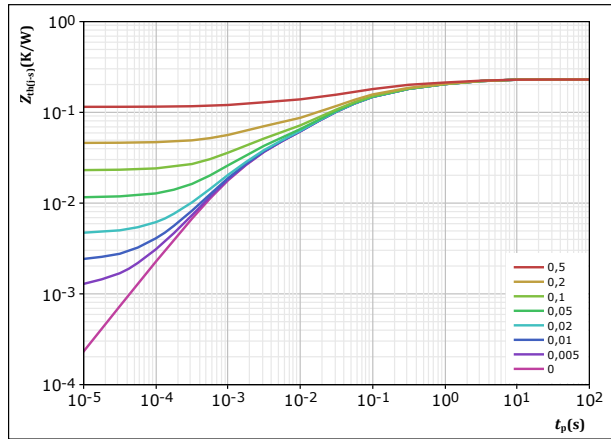

figure 18. FWD

Transient thermal impedance as a function of pulse width

$$Z_{th(j-s)} = f(t_p)$$



$D = \frac{t_p}{T}$

$R_{th(j-s)} = 0,23 \text{ K/W}$

FWD thermal model values

R (K/W)	τ (s)
2,56E-02	2,90E+00
4,35E-02	5,53E-01
9,09E-02	6,81E-02
4,34E-02	1,43E-02
2,66E-02	1,41E-03



Boost Sw. Protection Diode Characteristics

figure 19. FWD

Typical forward characteristics

$$I_F = f(V_F)$$

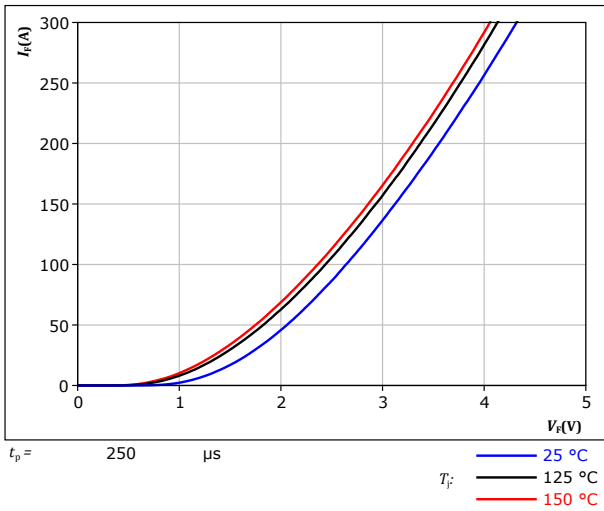
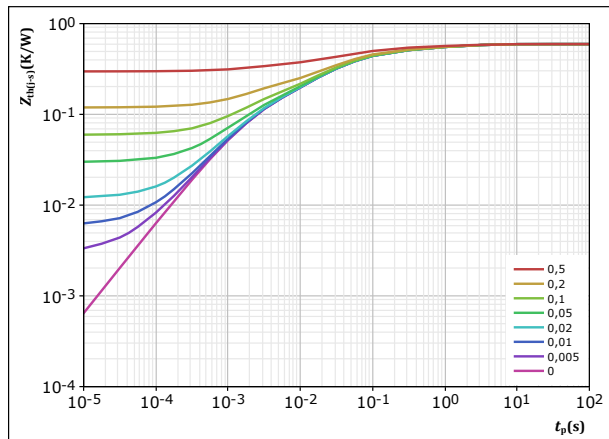

figure 20. FWD

Transient thermal impedance as a function of pulse width

$$Z_{th(j-s)} = f(t_p)$$



$D = t_p / T$
 $R_{th(j-s)} = 0,594 \text{ K/W}$
 FWD thermal model values

R (K/W)	τ (s)
5,02E-02	2,46E+00
7,95E-02	4,43E-01
2,28E-01	5,90E-02
1,50E-01	1,50E-02
8,75E-02	1,73E-03



Boost D. Protection Diode Characteristics

figure 21. FWD

Typical forward characteristics

$$I_F = f(V_F)$$

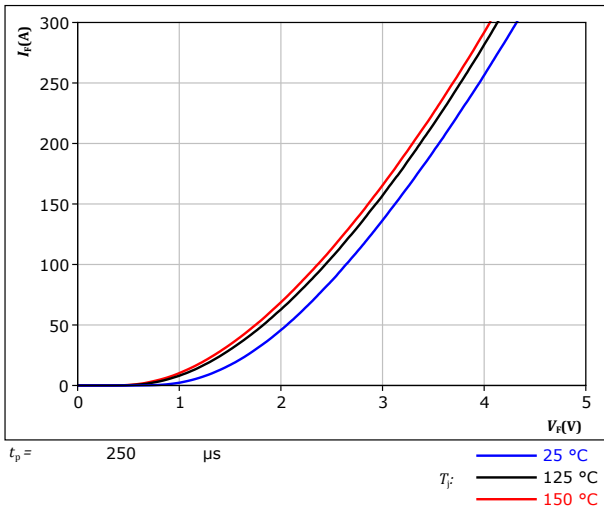
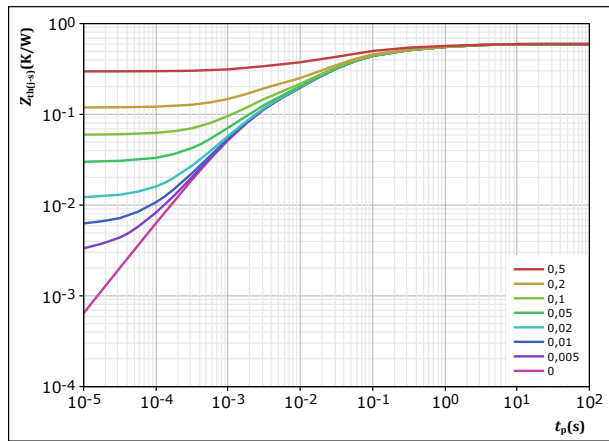

figure 22. FWD

Transient thermal impedance as a function of pulse width

$$Z_{th(j-s)} = f(t_p)$$



$D =$	t_p / T	
$R_{th(j-s)} =$	0,594	K/W
FWD thermal model values		
R (K/W)	τ (s)	
5,02E-02	2,46E+00	
7,95E-02	4,43E-01	
2,28E-01	5,90E-02	
1,50E-01	1,50E-02	
8,75E-02	1,73E-03	



Thermistor Characteristics

figure 23. Thermistor

Typical NTC characteristic as function of temperature

$$R_T = f(T)$$

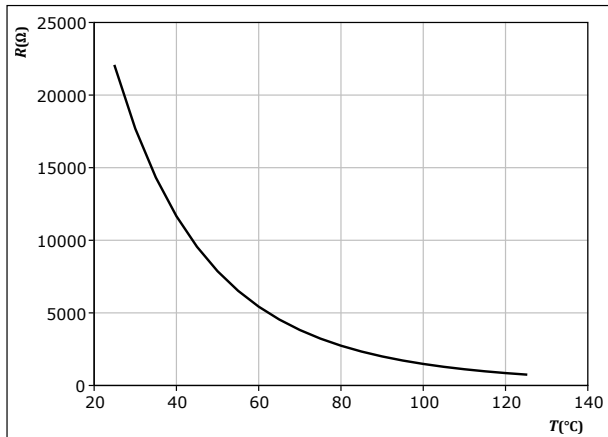



Buck Switching Characteristics

figure 24. IGBT

Typical switching energy losses as a function of collector current
 $E = f(I_c)$

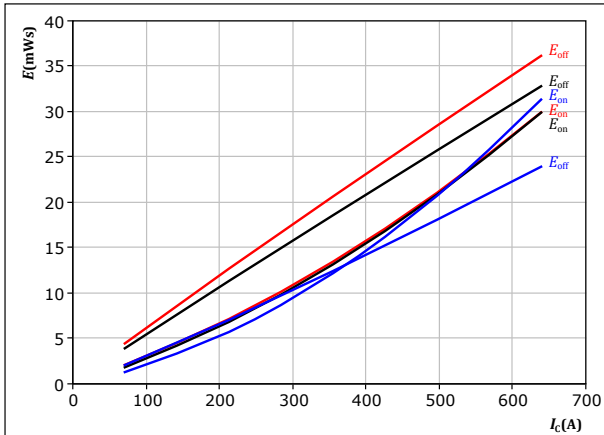

With an inductive load at

$V_{CE} =$	600	V	$T_f:$	—	25 °C
$V_{GE} =$	±15	V		—	125 °C
$R_{gon} =$	2	Ω		—	150 °C
$R_{goff} =$	4	Ω			

figure 25. IGBT

Typical switching energy losses as a function of IGBT turn on gate resistor
 $E = f(R_g)$

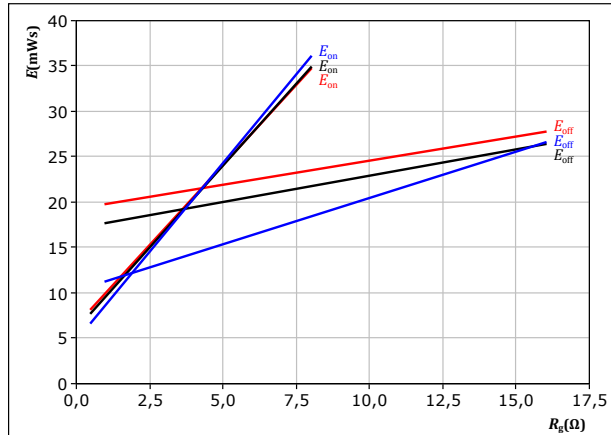

With an inductive load at

$V_{CE} =$	600	V	$T_f:$	—	25 °C
$V_{GE} =$	±15	V		—	125 °C
$I_c =$	355	A		—	150 °C

figure 26. FWD

Typical reverse recovered energy loss as a function of collector current
 $E_{rec} = f(I_c)$

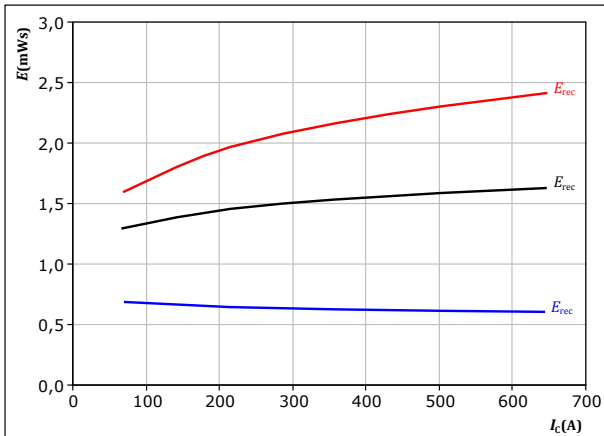

With an inductive load at

$V_{CE} =$	600	V	$T_f:$	—	25 °C
$V_{GE} =$	±15	V		—	125 °C
$R_{gon} =$	2	Ω		—	150 °C

figure 27. FWD

Typical reverse recovered energy loss as a function of IGBT turn on gate resistor
 $E_{rec} = f(R_g)$

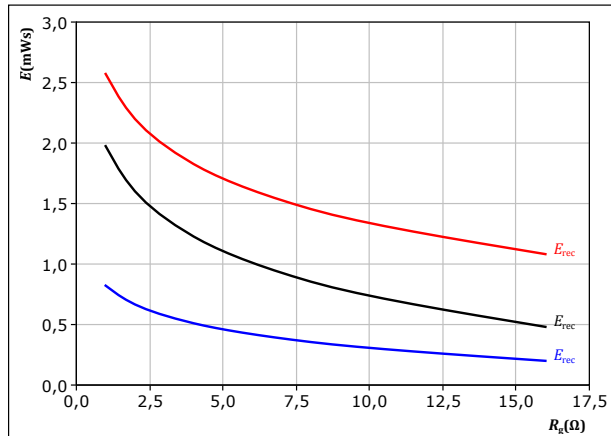

With an inductive load at

$V_{CE} =$	600	V	$T_f:$	—	25 °C
$V_{GE} =$	±15	V		—	125 °C
$I_c =$	355	A		—	150 °C



Buck Switching Characteristics

figure 28. IGBT

Typical switching times as a function of collector current
 $t = f(I_c)$

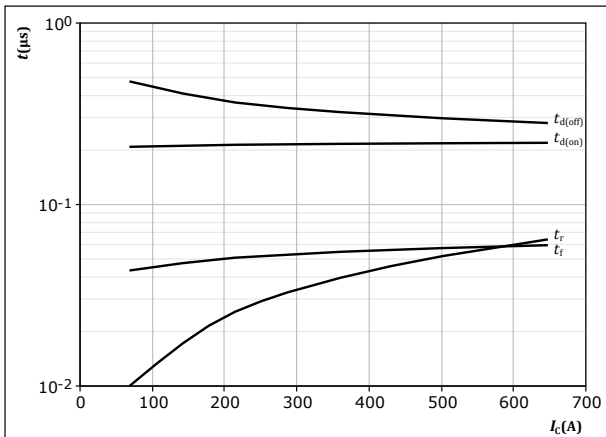

With an inductive load at
 $T_j = 150 \text{ }^\circ\text{C}$
 $V_{CE} = 600 \text{ V}$
 $V_{GE} = \pm 15 \text{ V}$
 $R_{gon} = 2 \text{ } \Omega$
 $R_{goff} = 4 \text{ } \Omega$

figure 29. IGBT

Typical switching times as a function of IGBT turn on gate resistor
 $t = f(R_g)$

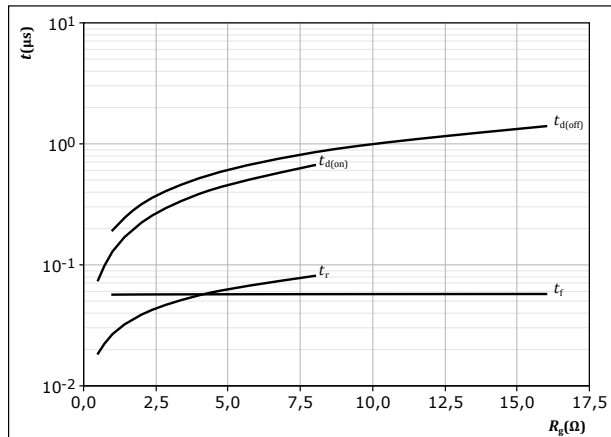

With an inductive load at
 $T_j = 150 \text{ }^\circ\text{C}$
 $V_{CE} = 600 \text{ V}$
 $V_{GE} = \pm 15 \text{ V}$
 $I_c = 355 \text{ A}$

figure 30. FWD

Typical reverse recovery time as a function of collector current
 $t_{rr} = f(I_c)$

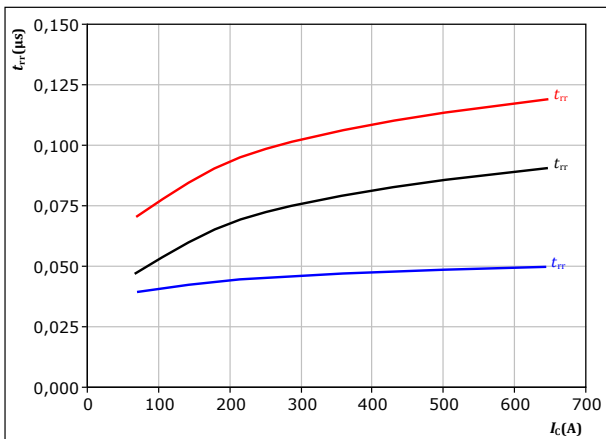

With an inductive load at
 $V_{CE} = 600 \text{ V}$
 $V_{GE} = \pm 15 \text{ V}$
 $R_{gon} = 2 \text{ } \Omega$
 $T_j: \text{ } \text{---} 25 \text{ }^\circ\text{C}$
 $\text{---} 125 \text{ }^\circ\text{C}$
 $\text{---} 150 \text{ }^\circ\text{C}$

figure 31. FWD

Typical reverse recovery time as a function of IGBT turn on gate resistor
 $t_{rr} = f(R_{gon})$

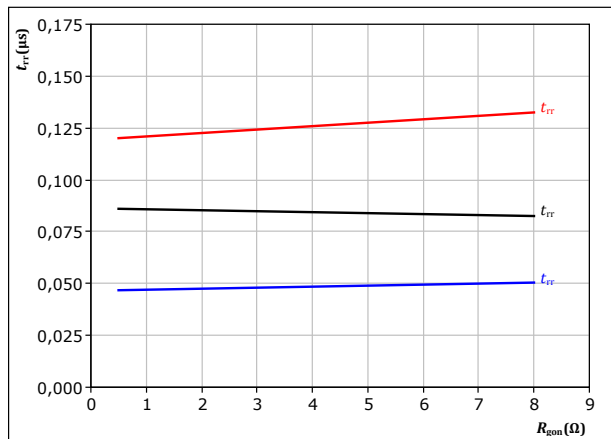

With an inductive load at
 $V_{CE} = 600 \text{ V}$
 $V_{GE} = \pm 15 \text{ V}$
 $I_c = 355 \text{ A}$
 $T_j: \text{ } \text{---} 25 \text{ }^\circ\text{C}$
 $\text{---} 125 \text{ }^\circ\text{C}$
 $\text{---} 150 \text{ }^\circ\text{C}$



Buck Switching Characteristics

figure 32. FWD

Typical recovered charge as a function of collector current

$$Q_r = f(I_c)$$

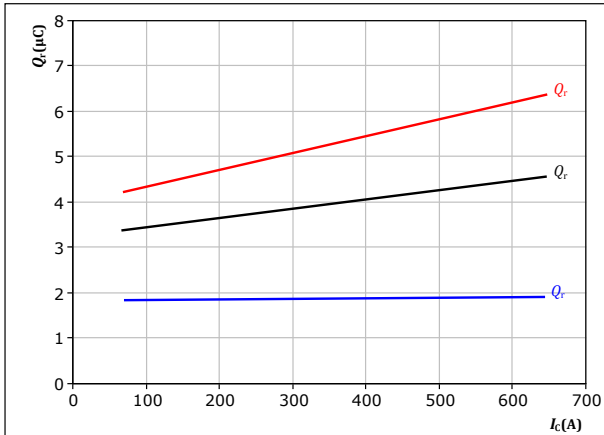

With an inductive load at

$V_{CE} = 600 \text{ V}$
 $V_{GE} = \pm 15 \text{ V}$
 $R_{gon} = 2 \ \Omega$

T_j : 25 °C (blue line)
 125 °C (black line)
 150 °C (red line)

figure 33. FWD

Typical recovered charge as a function of IGBT turn on gate resistor

$$Q_r = f(R_{gon})$$

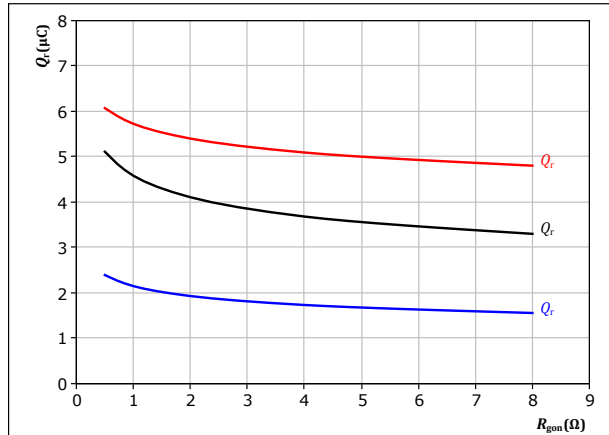

With an inductive load at

$V_{CE} = 600 \text{ V}$
 $V_{GE} = \pm 15 \text{ V}$
 $I_c = 355 \text{ A}$

T_j : 25 °C (blue line)
 125 °C (black line)
 150 °C (red line)

figure 34. FWD

Typical peak reverse recovery current as a function of collector current

$$I_{RM} = f(I_c)$$

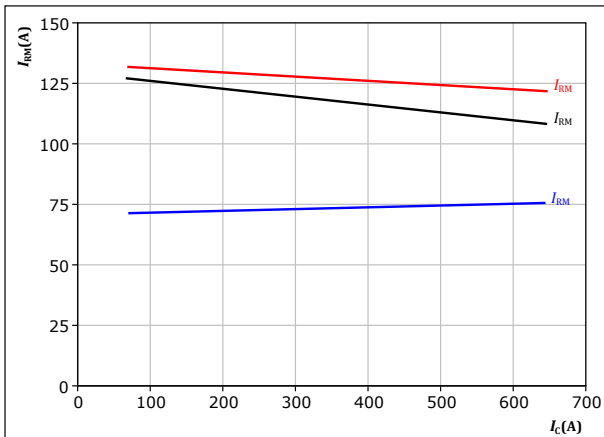

With an inductive load at

$V_{CE} = 600 \text{ V}$
 $V_{GE} = \pm 15 \text{ V}$
 $R_{gon} = 2 \ \Omega$

T_j : 25 °C (blue line)
 125 °C (black line)
 150 °C (red line)

figure 35. FWD

Typical peak reverse recovery current as a function of IGBT turn on gate resistor

$$I_{RM} = f(R_{gon})$$

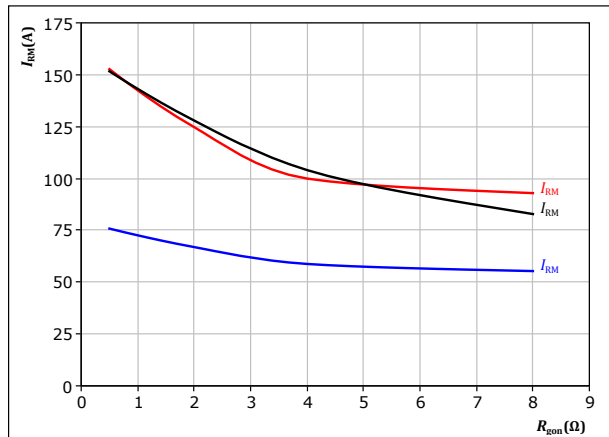

With an inductive load at

$V_{CE} = 600 \text{ V}$
 $V_{GE} = \pm 15 \text{ V}$
 $I_c = 355 \text{ A}$

T_j : 25 °C (blue line)
 125 °C (black line)
 150 °C (red line)



Buck Switching Characteristics

figure 36. FWD

Typical rate of fall of forward and reverse recovery current as a function of collector current
 $di_f/dt, di_r/dt = f(I_c)$

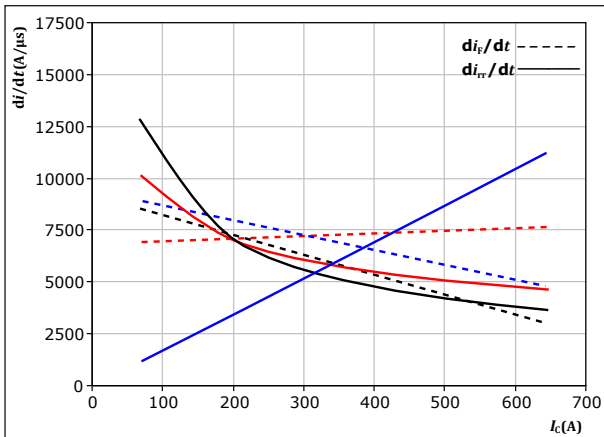

With an inductive load at

$V_{CE} = 600 \text{ V}$
 $V_{GE} = \pm 15 \text{ V}$
 $R_{gon} = 2 \text{ } \Omega$

$T_j = 25 \text{ } ^\circ\text{C}$
 $125 \text{ } ^\circ\text{C}$
 $150 \text{ } ^\circ\text{C}$

figure 37. FWD

Typical rate of fall of forward and reverse recovery current as a function of turn on gate resistor
 $di_f/dt, di_r/dt = f(R_{gon})$

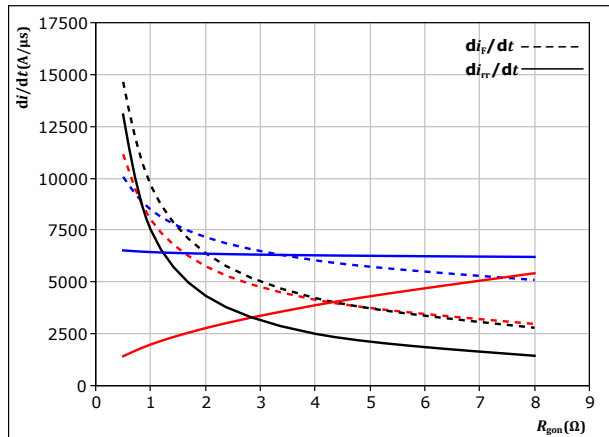

With an inductive load at

$V_{CE} = 600 \text{ V}$
 $V_{GE} = \pm 15 \text{ V}$
 $I_c = 355 \text{ A}$

$T_j = 25 \text{ } ^\circ\text{C}$
 $125 \text{ } ^\circ\text{C}$
 $150 \text{ } ^\circ\text{C}$

figure 38. IGBT

Reverse bias safe operating area

$I_c = f(V_{CE})$

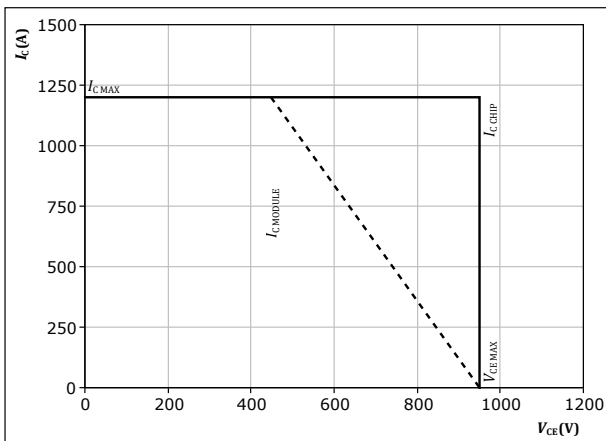

At $T_j = 150 \text{ } ^\circ\text{C}$
 $R_{gon} = 2 \text{ } \Omega$
 $R_{goff} = 4 \text{ } \Omega$



Boost Switching Characteristics

figure 39. IGBT

Typical switching energy losses as a function of collector current
 $E = f(I_c)$

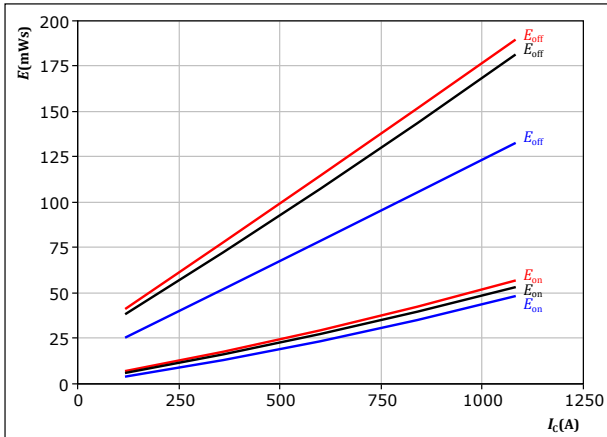

With an inductive load at
 $V_{CE} = 600 \text{ V}$
 $V_{GE} = \pm 15 \text{ V}$
 $R_{gon} = 2 \text{ } \Omega$
 $R_{goff} = 2 \text{ } \Omega$

T_j : — 25 °C
— 125 °C
— 150 °C

figure 40. IGBT

Typical switching energy losses as a function of IGBT turn on gate resistor
 $E = f(R_g)$

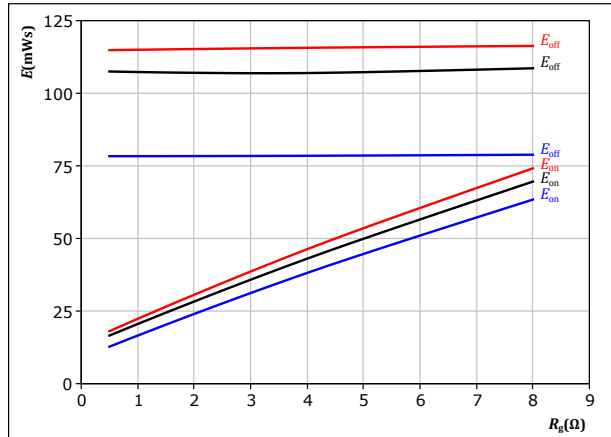

With an inductive load at
 $V_{CE} = 600 \text{ V}$
 $V_{GE} = \pm 15 \text{ V}$
 $I_c = 600 \text{ A}$

T_j : — 25 °C
— 125 °C
— 150 °C

figure 41. FWD

Typical reverse recovered energy loss as a function of collector current
 $E_{rec} = f(I_c)$

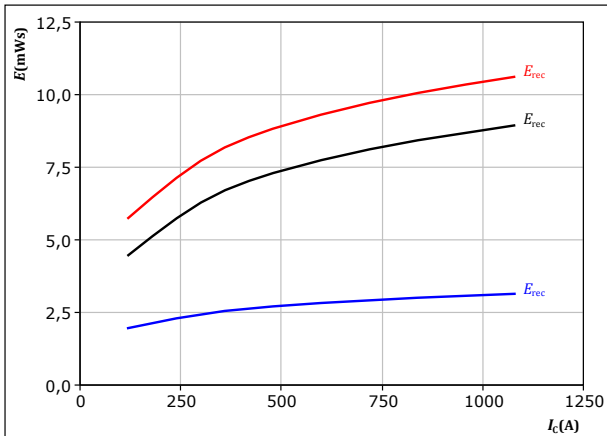

With an inductive load at
 $V_{CE} = 600 \text{ V}$
 $V_{GE} = \pm 15 \text{ V}$
 $R_{gon} = 2 \text{ } \Omega$

T_j : — 25 °C
— 125 °C
— 150 °C

figure 42. FWD

Typical reverse recovered energy loss as a function of IGBT turn on gate resistor
 $E_{rec} = f(R_g)$

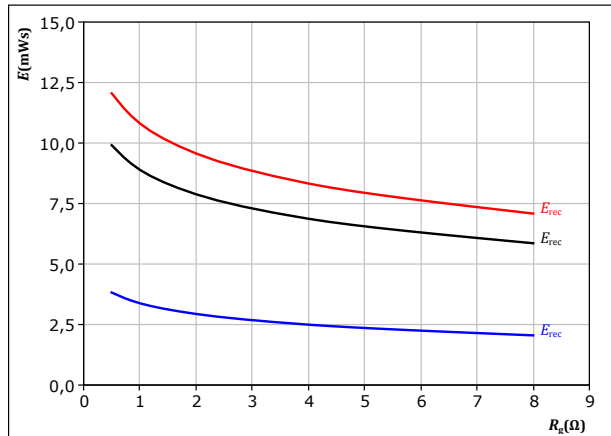

With an inductive load at
 $V_{CE} = 600 \text{ V}$
 $V_{GE} = \pm 15 \text{ V}$
 $I_c = 600 \text{ A}$

T_j : — 25 °C
— 125 °C
— 150 °C



Boost Switching Characteristics

figure 43. IGBT

Typical switching times as a function of collector current
 $t = f(I_c)$

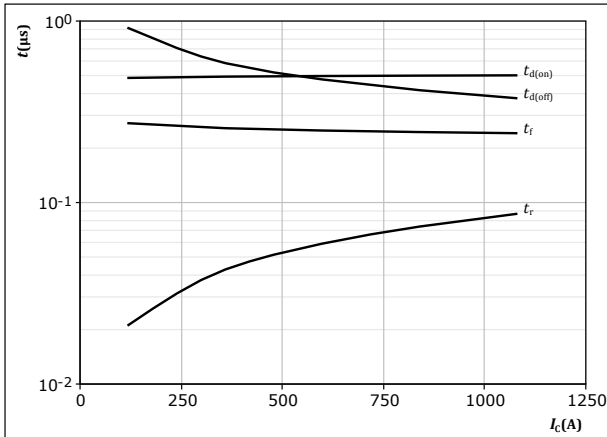

With an inductive load at
 $T_j = 150 \text{ }^\circ\text{C}$
 $V_{CE} = 600 \text{ V}$
 $V_{GE} = \pm 15 \text{ V}$
 $R_{g(on)} = 2 \text{ } \Omega$
 $R_{g(off)} = 2 \text{ } \Omega$

figure 44. IGBT

Typical switching times as a function of gate resistor
 $t = f(R_g)$

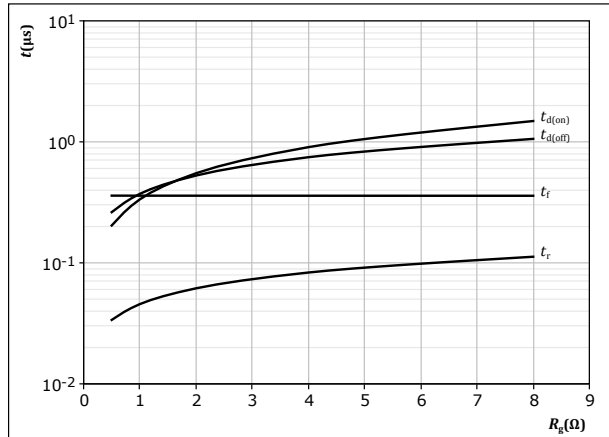

With an inductive load at
 $T_j = 150 \text{ }^\circ\text{C}$
 $V_{CE} = 600 \text{ V}$
 $V_{GE} = \pm 15 \text{ V}$
 $I_c = 600 \text{ A}$

figure 45. FWD

Typical reverse recovery time as a function of collector current
 $t_{rr} = f(I_c)$

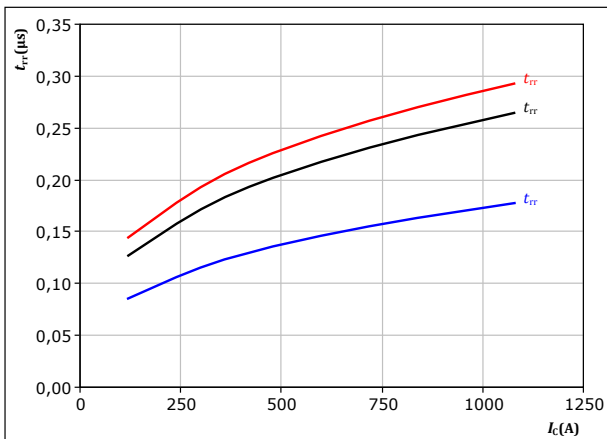

With an inductive load at
 $V_{CE} = 600 \text{ V}$
 $V_{GE} = \pm 15 \text{ V}$
 $R_{g(on)} = 2 \text{ } \Omega$
 $T_j: \text{ } \text{---} 25 \text{ }^\circ\text{C}$
 $\text{---} 125 \text{ }^\circ\text{C}$
 $\text{---} 150 \text{ }^\circ\text{C}$

figure 46. FWD

Typical reverse recovery time as a function of IGBT turn off gate resistor
 $t_{rr} = f(R_{g(off)})$

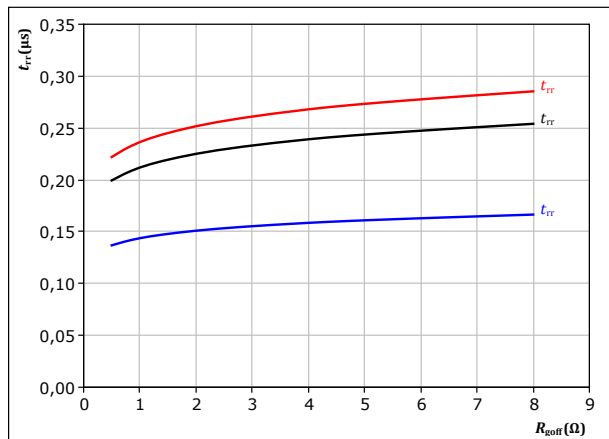

With an inductive load at
 $V_{CE} = 600 \text{ V}$
 $V_{GE} = \pm 15 \text{ V}$
 $I_c = 600 \text{ A}$
 $T_j: \text{ } \text{---} 25 \text{ }^\circ\text{C}$
 $\text{---} 125 \text{ }^\circ\text{C}$
 $\text{---} 150 \text{ }^\circ\text{C}$



Boost Switching Characteristics

figure 47. FWD

Typical recovered charge as a function of collector current

$$Q_r = f(I_c)$$

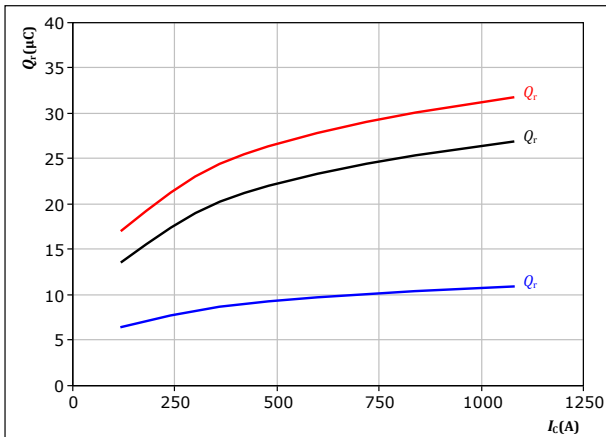

With an inductive load at

$V_{CE} = 600$ V
 $V_{GE} = \pm 15$ V
 $R_{goff} = 2$ Ω

T_j : — 25 °C
 — 125 °C
 — 150 °C

figure 48. FWD

Typical recovered charge as a function of turn off gate resistor

$$Q_r = f(R_{goff})$$

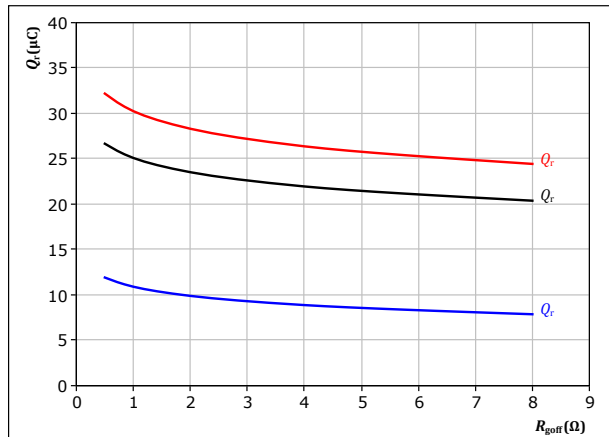

With an inductive load at

$V_{CE} = 600$ V
 $V_{GE} = \pm 15$ V
 $I_c = 600$ A

T_j : — 25 °C
 — 125 °C
 — 150 °C

figure 49. FWD

Typical peak reverse recovery current as a function of collector current

$$I_{RM} = f(I_c)$$

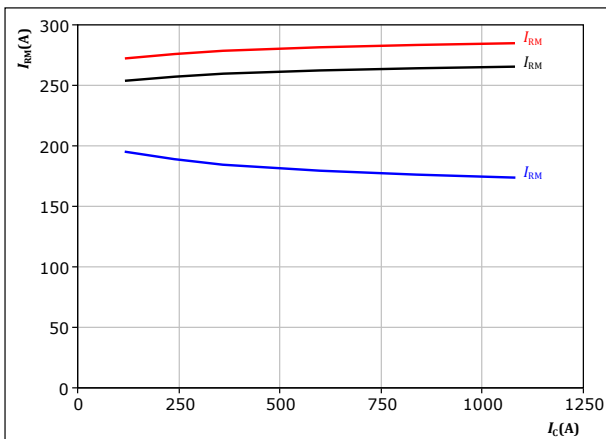

With an inductive load at

$V_{CE} = 600$ V
 $V_{GE} = \pm 15$ V
 $R_{goff} = 2$ Ω

T_j : — 25 °C
 — 125 °C
 — 150 °C

figure 50. FWD

Typical peak reverse recovery current as a function of turn off gate resistor

$$I_{RM} = f(R_{goff})$$

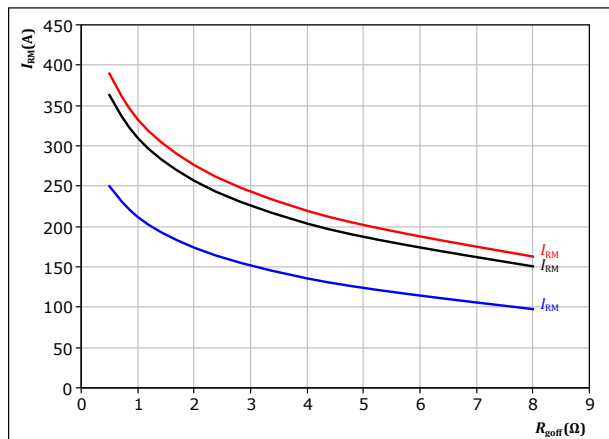

With an inductive load at

$V_{CE} = 600$ V
 $V_{GE} = \pm 15$ V
 $I_c = 600$ A

T_j : — 25 °C
 — 125 °C
 — 150 °C



Boost Switching Characteristics

figure 51. FWD

Typical rate of fall of forward and reverse recovery current as a function of collector current
 $di_f/dt, di_{rr}/dt = f(I_c)$

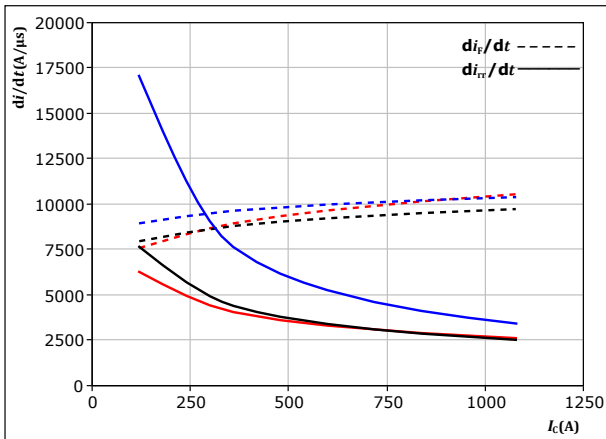

With an inductive load at

$V_{CE} = 600 \text{ V}$
 $V_{GE} = \pm 15 \text{ V}$
 $R_{goff} = 2 \text{ } \Omega$

$T_j = 25 \text{ } ^\circ\text{C}$
 $125 \text{ } ^\circ\text{C}$
 $150 \text{ } ^\circ\text{C}$

figure 52. FWD

Typical rate of fall of forward and reverse recovery current as a function of turn off gate resistor
 $di_f/dt, di_{rr}/dt = f(R_{goff})$

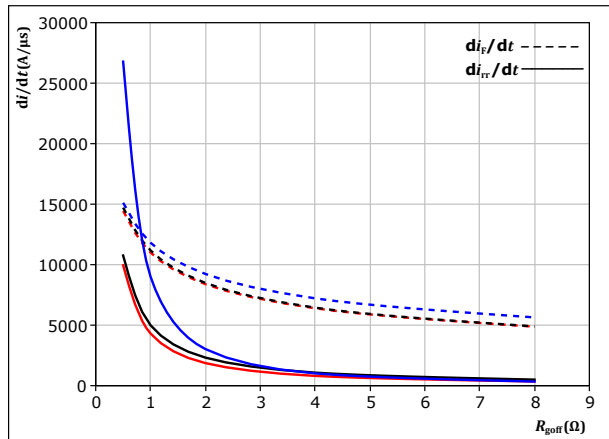

With an inductive load at

$V_{CE} = 600 \text{ V}$
 $V_{GE} = \pm 15 \text{ V}$
 $I_c = 600 \text{ A}$

$T_j = 25 \text{ } ^\circ\text{C}$
 $125 \text{ } ^\circ\text{C}$
 $150 \text{ } ^\circ\text{C}$

figure 53. IGBT

Reverse bias safe operating area

$I_c = f(V_{CE})$

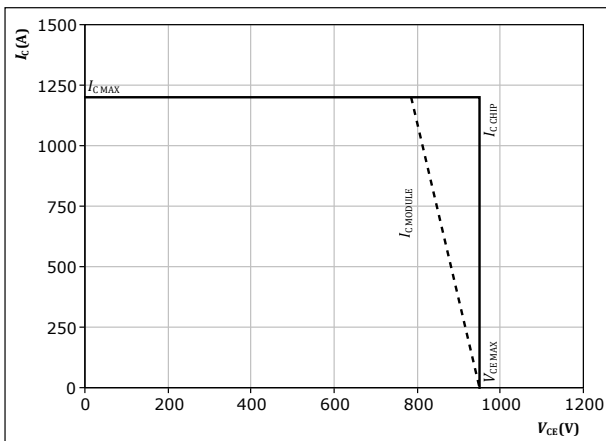

At $T_j = 150 \text{ } ^\circ\text{C}$
 $R_{goff} = 2 \text{ } \Omega$
 $R_{goff} = 2 \text{ } \Omega$



Switching Definitions

figure 54. IGBT

Turn-off Switching Waveforms & definition of t_{doff} , t_{Eoff} (t_{Eoff} = integrating time for E_{off})

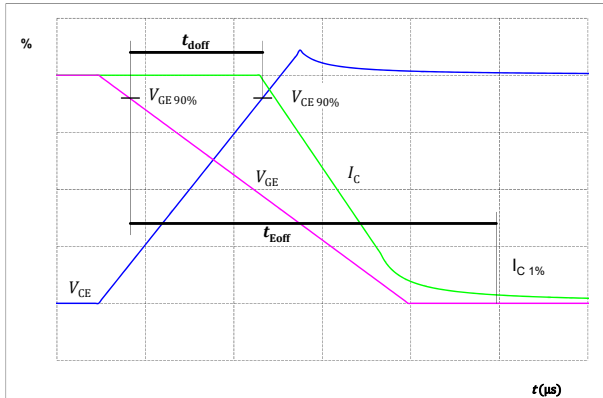

figure 55. IGBT

Turn-on Switching Waveforms & definition of t_{don} , t_{Eon} (t_{Eon} = integrating time for E_{on})

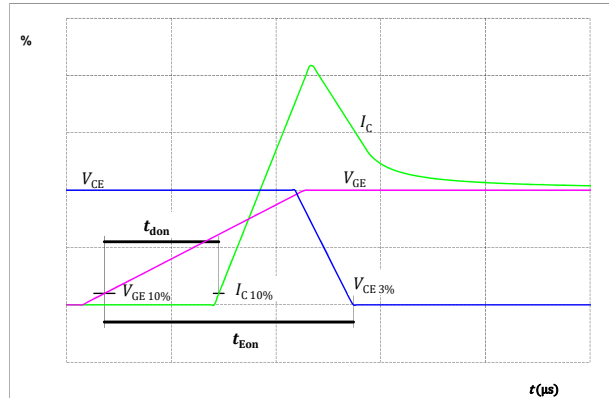

figure 56. IGBT

Turn-off Switching Waveforms & definition of t_f

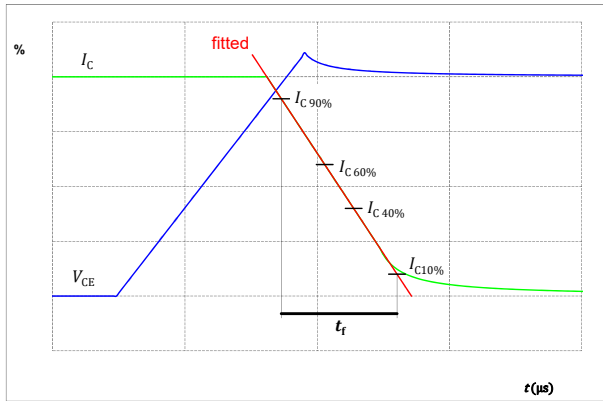
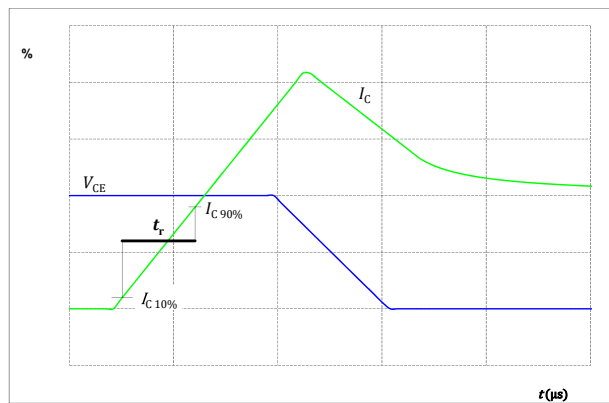

figure 57. IGBT

Turn-on Switching Waveforms & definition of t_r





Switching Definitions

figure 58. FWD

Turn-off Switching Waveforms & definition of t_{rr}

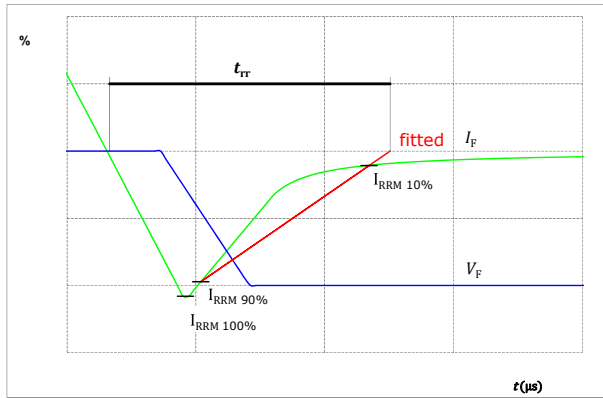
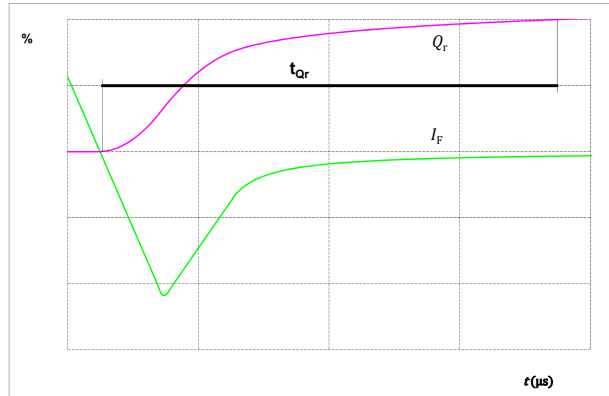

figure 59. FWD

Turn-on Switching Waveforms & definition of t_{Qr} (t_{Qr} = integrating time for Q_r)





Vincotech

B0-SL10NIB600S701-PA29F48Z
B0-SL10NIC600S701-PA39F48Z

datasheet

Ordering Code	
Version	Ordering Code
With thermal paste (4,4 W/mK, PTM6000)	B0-SL10NIB600S701-PA29F48Z-/7/

Marking						
	Text	Name	Date code	UL & VIN	Lot	Serial
		NN-NNNNNNNNNNNNNNNN- TTTTIVV	WWYY	UL VIN	LLLLL	SSSS
	Datamatrix	Type&Ver	Lot number	Serial	Date code	
		TTTTIVV	LLLLL	SSSS	WWYY	

High Side Module B0-SL10NIB600S701-PA29F48Z

Pin table [mm]				Outline	
Pin	X	Y	Function		
1	6,2	49,4	Therm1		
2	0	49,4	Therm2		
3	0,3	5,4	DC+		
4	3	5,4	DC+		
5	5,7	5,4	DC+		
6	8,4	5,4	DC+		
7	0,3	2,7	DC+		
8	3	2,7	DC+		
9	5,7	2,7	DC+		
10	0,3	0	DC+		
11	3	0	DC+		
12	5,7	0	DC+		
13	14,5	0	GND		
14	17,2	0	GND		
15	19,9	0	GND		
16	22,6	0	GND		
17	31,8	0	GND		
18	34,5	0	GND		
19	37,2	0	GND		
20	39,9	0	GND		
21	48,7	0	DC-		
22	51,4	0	DC-		
23	51,4	2,7	DC-		
24	51,4	5,4	DC-		
25	51,4	8,1	DC-		
26	51,4	10,8	DC-		
27	51,4	13,5	DC-		
28	40,6	43,7	Ph		
29	37,9	43,7	Ph		
30	35,2	43,7	Ph		
31	40,6	46,4	Ph		
32	37,9	46,4	Ph		
33	35,2	46,4	Ph		
34	40,6	49,1	Ph		
35	37,9	49,1	Ph		
36	35,2	49,1	Ph		
37	32,5	49,1	Ph		
38	12,4	26,95	G11		
39	16,1	26,95	S11		
40	32,95	27,3	G13		
41	36,65	27,3	S13		
42	21,05	49,1	P		
43	51,4	33,6	N		

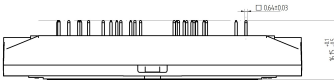
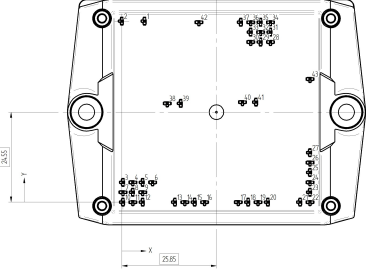
Tolerance of positions: ±0,05mm at the end of pins
 Dimension of contacts pin is only of reference tolerance



Vincotech

B0-SL10NIB600S701-PA29F48Z
B0-SL10NIC600S701-PA39F48Z

datasheet

High Side Module B0-SL10NIB600S701-PA29F48Z

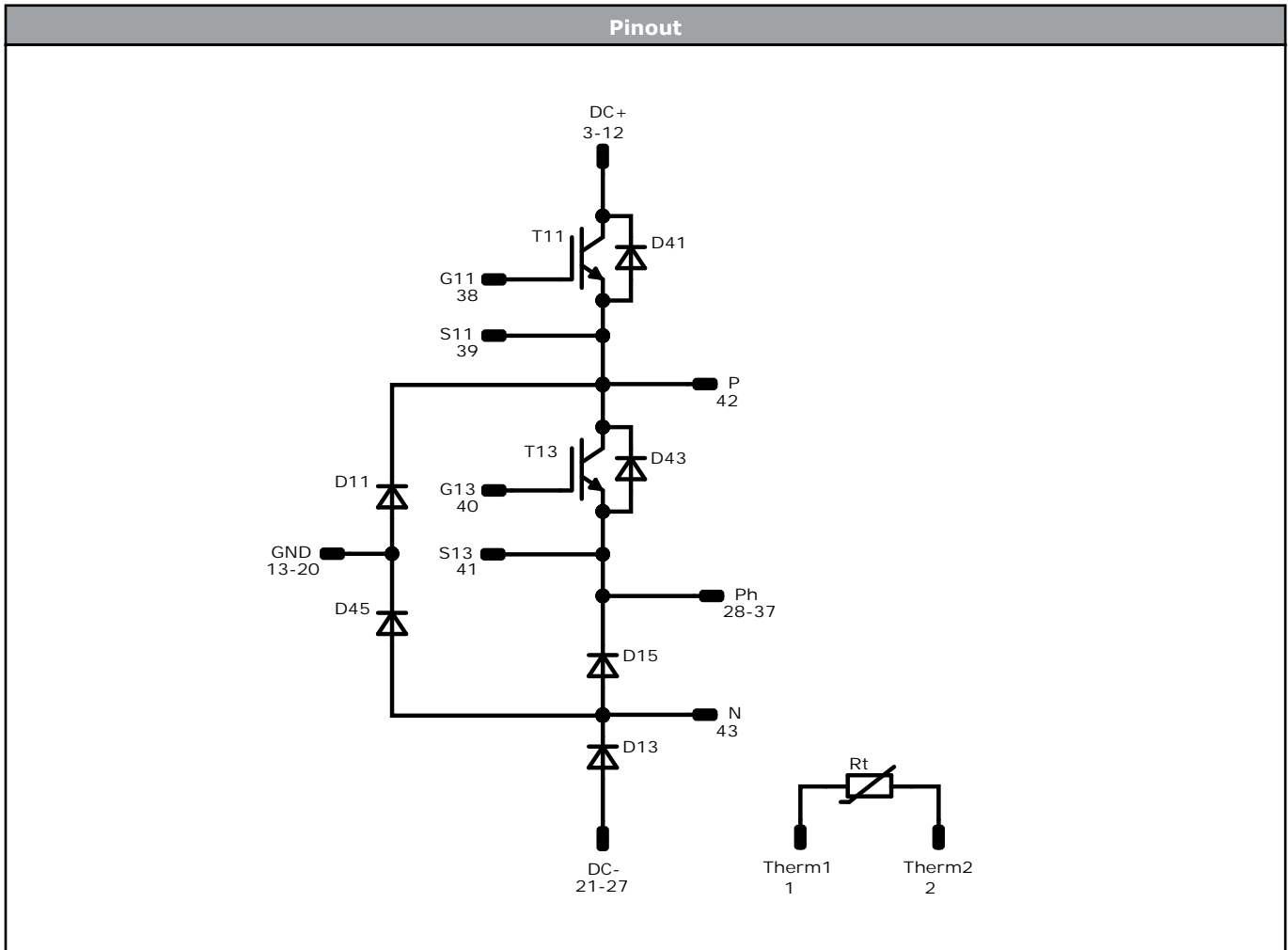

Identification					
ID	Component	Voltage	Current	Function	Comment
T11	IGBT	950 V	600 A	Buck Switch	
D11	FWD	1200 V	160 A	Buck Diode	
D41	FWD	950 V	100 A	Buck Sw. Protection Diode	
T13	IGBT	950 V	600 A	Boost Switch	
D13	FWD	950 V	300 A	Boost Diode	
D15	FWD	950 V	300 A	Boost Sw. Inv. Diode	
D43	FWD	950 V	100 A	Boost Sw. Protection Diode	
D45	FWD	950 V	100 A	Boost D. Protection Diode	
Rt	Thermistor			Thermistor	



Vincotech

B0-SL10NIB600S701-PA29F48Z
B0-SL10NIC600S701-PA39F48Z

datasheet

Ordering Code	
Version	Ordering Code
With thermal paste (4,4 W/mK, PTM6000)	B0-SL10NIC600S701-PA39F48Z-/7/

Marking						
	Text	Name NN-NNNNNNNNNNNNNNNN- TTTTIVV	Date code WWYY	UL & VIN UL VIN	Lot LLLLL	Serial SSSS
	Datamatrix	Type&Ver TTTTIVV	Lot number LLLLL	Serial SSSS	Date code WWYY	

Low Side Module B0-SL10NIC600S701-PA39F48Z

Pin table [mm]			
Pin	X	Y	Function
1	51,45	49,45	Therm1
2	46	49,45	Therm2
3	21,8	49,1	Ph
4	19,1	49,1	Ph
5	16,4	49,1	Ph
6	13,7	49,1	Ph
7	11	49,1	Ph
8	21,8	46,4	Ph
9	19,1	46,4	Ph
10	16,4	46,4	Ph
11	13,7	46,4	Ph
12	11	46,4	Ph
13	0	25	DC+
14	0	22,3	DC+
15	0	19,6	DC+
16	0	16,9	DC+
17	0	14,2	DC+
18	0	11,5	DC+
19	0	8,8	DC+
20	0	0	GND
21	2,6	0	GND
22	5,2	0	GND
23	7,8	0	GND
24	39	0	GND
25	41,6	0	GND
26	44,2	0	GND
27	46,8	0	GND
28	51,1	6,45	DC-
29	48,4	9,15	DC-
30	51,1	9,15	DC-
31	51,1	11,85	DC-
32	51,1	14,55	DC-
33	51,1	17,25	DC-
34	48,4	19,95	DC-
35	51,1	19,95	DC-
36	51,1	22,65	DC-
37	51,1	25,35	DC-
38	28,6	26,95	G14
39	32,3	26,95	S14
40	46,05	29,35	G12
41	49,75	29,35	S12
42	7,35	33,6	P
43	32,3	49,1	N

Outline

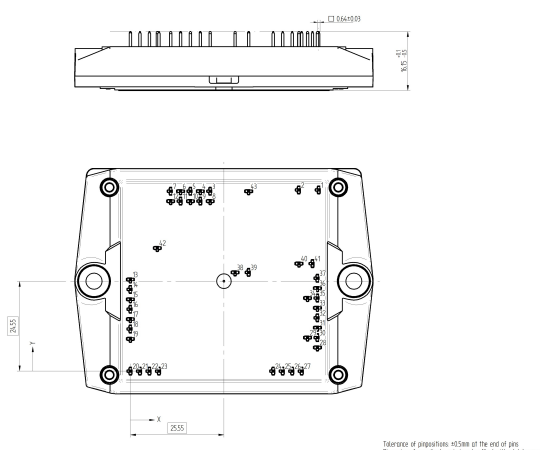



Vincotech

B0-SL10NIB600S701-PA29F48Z
B0-SL10NIC600S701-PA39F48Z

datasheet

Low Side Module B0-SL10NIC600S701-PA39F48Z

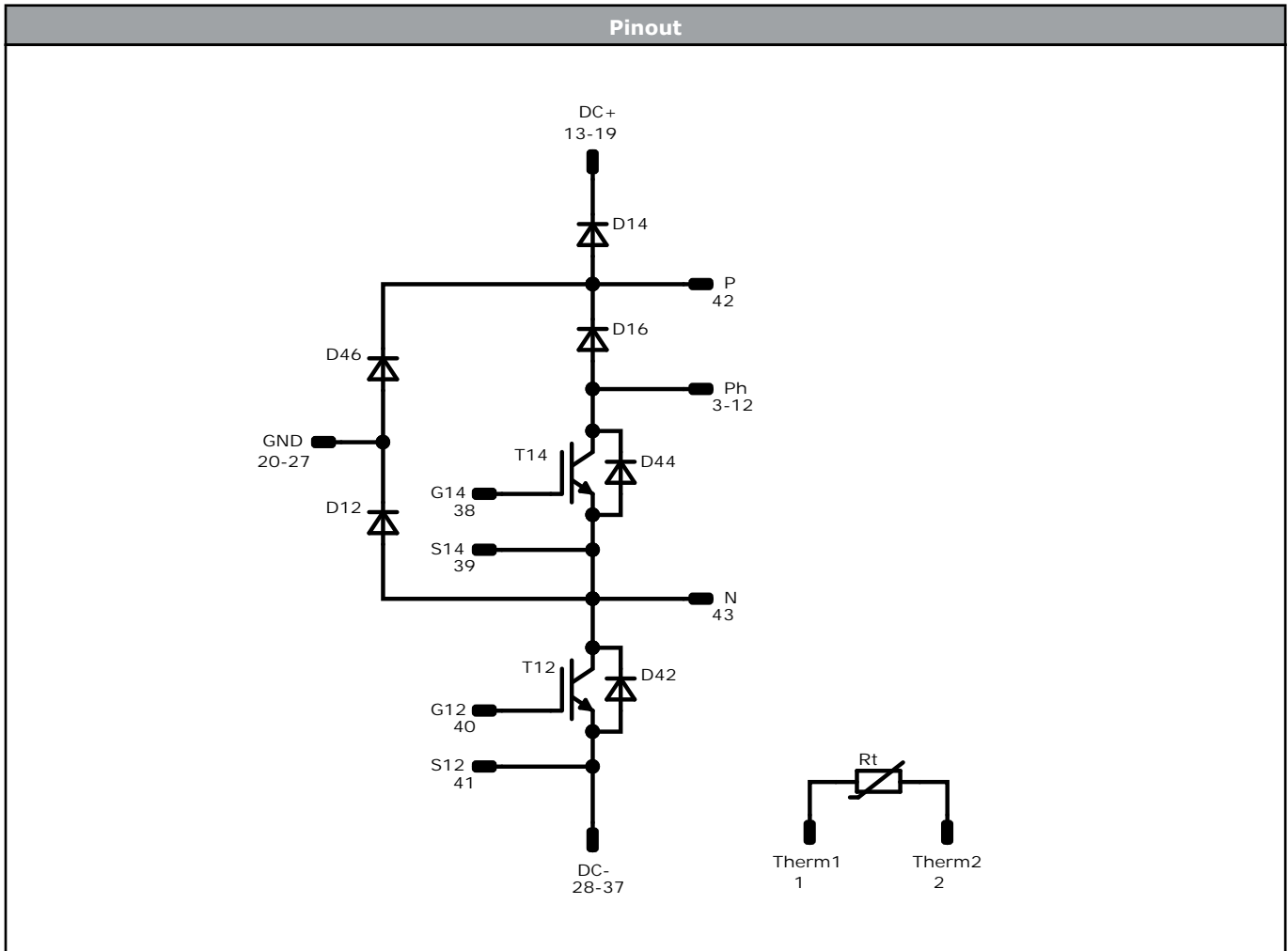

Identification					
ID	Component	Voltage	Current	Function	Comment
T12	IGBT	950 V	600 A	Buck Switch	
D12	FWD	1200 V	160 A	Buck Diode	
D42	FWD	950 V	100 A	Buck Sw. Protection Diode	
T14	IGBT	950 V	600 A	Boost Switch	
D14	FWD	950 V	300 A	Boost Diode	
D16	FWD	950 V	300 A	Boost Sw. Inv. Diode	
D44	FWD	950 V	100 A	Boost Sw. Protection Diode	
D46	FWD	950 V	100 A	Boost D. Protection Diode	
Rt	Thermistor			Thermistor	



Packaging instruction				
Standard packaging quantity (SPQ) 45	>SPQ	Standard	<SPQ	Sample

Handling instruction
Handling instructions for <i>flow</i> S3 packages see vincotech.com website.

Package data
Package data for <i>flow</i> S3 packages see vincotech.com website.

Vincotech thermistor reference
See Vincotech thermistor reference table at vincotech.com website.

UL recognition and file number
This device is certified according to UL 1557 standard, UL file number E192116. For more information see vincotech.com website. 

Document No.:	Date:	Modification:	Pages
B0-SL10Nix600S701-PAx9F48Z-D2-14	8 May. 2022	Buck dynamic with asymmetric Rg	

DISCLAIMER

The information, specifications, procedures, methods and recommendations herein (together "information") are presented by Vincotech to reader in good faith, are believed to be accurate and reliable, but may well be incomplete and/or not applicable to all conditions or situations that may exist or occur. Vincotech reserves the right to make any changes without further notice to any products to improve reliability, function or design. No representation, guarantee or warranty is made to reader as to the accuracy, reliability or completeness of said information or that the application or use of any of the same will avoid hazards, accidents, losses, damages or injury of any kind to persons or property or that the same will not infringe third parties rights or give desired results. It is reader's sole responsibility to test and determine the suitability of the information and the product for reader's intended use.

LIFE SUPPORT POLICY

Vincotech products are not authorised for use as critical components in life support devices or systems without the express written approval of Vincotech.

As used herein:

1. Life support devices or systems are devices or systems which, (a) are intended for surgical implant into the body, or (b) support or sustain life, or (c) whose failure to perform when properly used in accordance with instructions for use provided in labelling can be reasonably expected to result in significant injury to the user.
2. A critical component is any component of a life support device or system whose failure to perform can be reasonably expected to cause the failure of the life support device or system, or to affect its safety or effectiveness.

单击下面可查看定价，库存，交付和生命周期等信息

[>>Vincotech\(威科\)](#)