

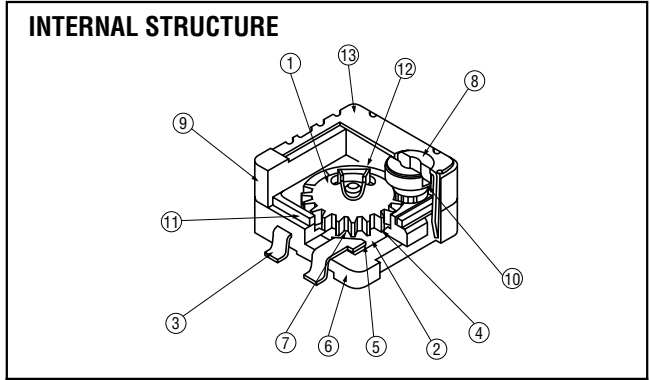

FEATURES

- Fine adjustment is possible
- Automatic mounting is possible (Taping)
- Flow/reflow soldering is possible
- Sealed construction (Washable)



Part name	Material	Flammability
① Rotor gear	PPS (Polyphenylenesulphide)	UL-94V-0
② Base element	Ceramic	—
③ Terminal pin	Copper alloy, Solder-plated	
④ Resistive element	RuO ₂ cermet	
⑤ Electrode	Ag-Pd cermet	UL-94V-0
⑥ Housing base	PPS (Polyphenylenesulphide)	
⑦ Wiper	Multi metal alloy	—
⑧ Shaft	PPS (Polyphenylenesulphide)	UL-94V-0
⑨ Housing		
⑩ Shaft "O" ring	Silicone rubber	UL-94HB
⑪ Base "O" ring		
⑫ Clutch spring	Stainless steel	—
⑬ Cover		

CFCs, Halon, Carbon tetrachloride and designated bromic flame retardant PBBs and PBBs are not used in our products.

PART NUMBER DESIGNATION

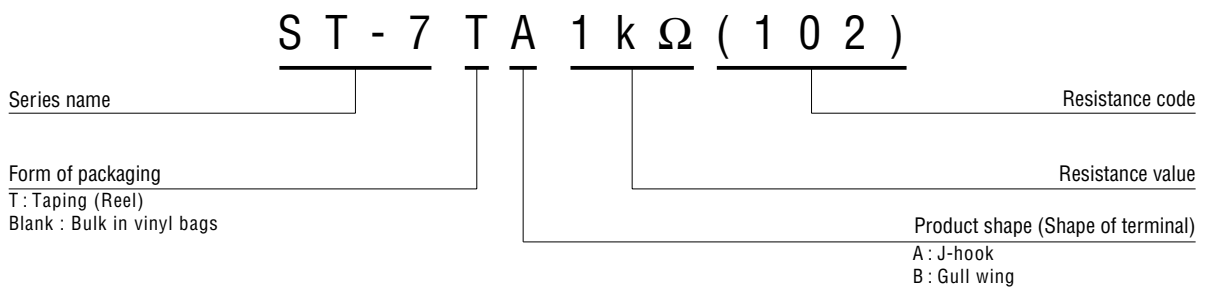

* Please refer to the LIST OF PART NUMBERS when placing orders.

LIST OF PART NUMBERS

Adjustment position	Shape of terminal	Form of packaging	
		Taping (reel)	Bulk packaging
Top adjustment	A (J-hook)	ST-7TA	ST-7A
	B (Gull wing)	ST-7TB	ST-7B
Pieces in package		500 pcs./reel	50 pcs./pack

<Nominal resistance values>

50 Ω	100 Ω	200 Ω	500 Ω	1 kΩ	2 kΩ	5 kΩ
10 kΩ	20 kΩ	50 kΩ	100 kΩ	200 kΩ	500 kΩ	1 MΩ

Fig. 1

- * The above part numbers are all available with the respective combination of <Nominal resistance values> (Fig. 1).
- * Verify the above part numbers when placing orders.
- * Taping version must be purchased in reel units.

ELECTRICAL CHARACTERISTICS

Nominal resistance range	50 Ω ~ 1 MΩ
Total resistance tolerance	± 20 %
Power ratings	0.25 W (70 °C) 0 W (125 °C)
Resistance law	Linear law
Maximum input voltage	DC200 V or power rating, whichever is smaller
Maximum wiper current	100 mA or power rating, whichever is smaller
Effective electrical turn	2.5 turns
End resistance	1 % or 2 Ω, whichever is greater
C.R.V.	1 % or 3 Ω, whichever is greater
Operating temp. range	-55 ~ +125 °C
Temp. coefficient	50 Ω : ± 250 ppm/°C maximum 100 Ω ~ 1 MΩ : ± 100 ppm/°C maximum
Insulation resistance	1000 MΩ minimum (DC500 V)
Dielectric strength	AC600 V, 60 s
Net weight	Approx. 0.25 g

MECHANICAL CHARACTERISTICS

Mechanical turn	3 turns
Operating torque	5 mN·m {51 gf·cm} maximum
Mechanical stop	Clutch action
Rotational life	100 cycles [ΔR/R ≤ ± (2 Ω + 3 %)]
Thrust to shaft	5 N {0.51 kgf} minimum
Solderability	235 °C, 2 s
Shear (Adhesion)	5 N {0.51 kgf} 10 s
Substrate bending	Width 90 mm, bend 3 mm, 5 s, 1 time
Pull-off strength	5 N {0.51 kgf} 10 s

{ } : Reference only

ENVIRONMENTAL CHARACTERISTICS

Test item	Test conditions	Specifications
Thermal shock	-65 ~ +125 °C (0.5 h), 5 cycles	[ΔR/R ≤ 2 %] [S.S. ≤ 1 %]
Humidity	-10 ~ +65 °C (80 ~ 98 %RH), 10 cycles, 240 h	[ΔR/R ≤ 2 %]
Shock	981 m/s ² , 6 ms 6 directions for 3 times each	[ΔR/R ≤ 1 %] [S.S. ≤ 1 %]
Vibration	Amplitude of 1.52 mm or Acceleration of 196 m/s ² , 10~2000 Hz, 3 directions, 12 times each	[ΔR/R ≤ 1 %] [S.S. ≤ 1 %]
Load life	70 °C, 0.25 W, 1000 h	[ΔR/R ≤ 3 %] [S.S. ≤ 1 %]
Low temp. operation	-55 °C, 2 h	[ΔR/R ≤ 2 %] [S.S. ≤ 2 %]
High temp. exposure	125 °C, 250 h	[ΔR/R ≤ 3 %] [S.S. ≤ 2 %]
Immersion seal	85 °C, 60 s	No leaks (No continuous bubbles)
Soldering heat	260 °C, 10 s or 215 °C, 35 s	[ΔR/R ≤ 1 %]

ΔR/R : Change in total resistance
S.S. : Setting stability

ST-7

SURFACE MOUNT TYPE TRIMMERS

MAXIMUM INPUT RATINGS

Nominal resistance values (Ω)	Resistance code	Maximum input voltage (V)	Maximum wiper current (mA)
50	500	3.53	70.7
100	101	5.00	50.0
200	201	7.07	35.4
500	501	11.2	22.4
1 k	102	15.8	15.8
2 k	202	22.4	11.2
5 k	502	35.4	7.07
10 k	103	50.0	5.00
20 k	203	70.7	3.54
50 k	503	112	2.24
100 k	104	158	1.58
200 k	204	200	1.00
500 k	504	200	0.40
1 M	105	200	0.20

RECOMMENDED P.C.B. PAD OUTLINE DIMENSIONS

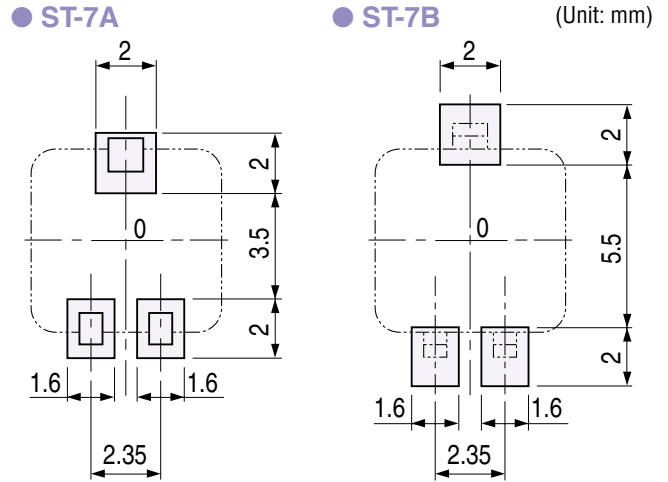

Note) The zero point is the center of mounting.

OUTLINE DIMENSIONS

ST-7A Top adjustment

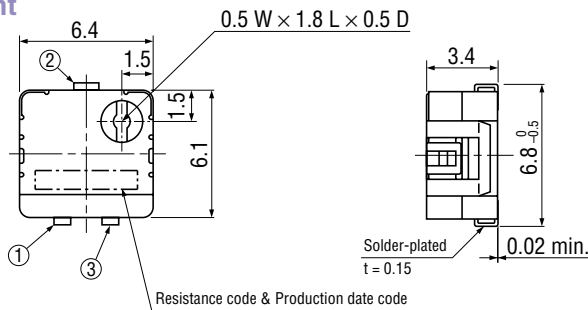

Unless otherwise specified, tolerance : ± 0.3 (Unit: mm)

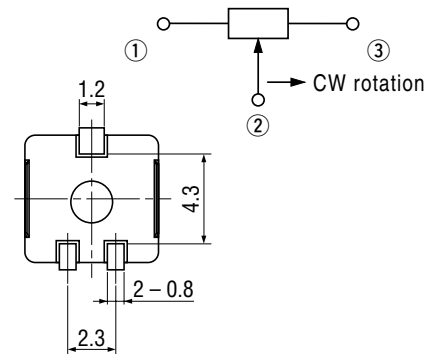

ST-7B Top adjustment

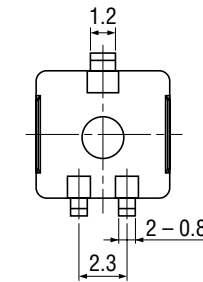
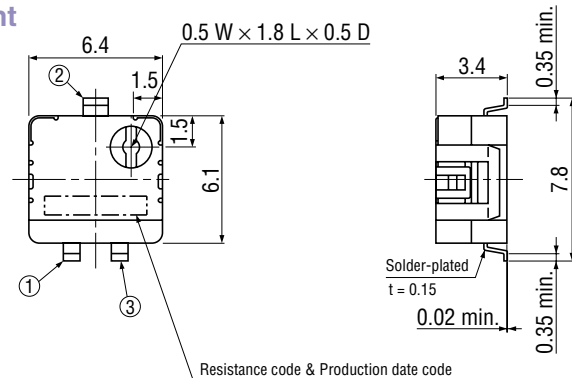

* The ST-7 series has a different terminal arrangement from the ST-3 and ST-4 series. Pay attention to the location of terminals number 1 and 3. (Resistance decreases when the shaft is turned CCW.)

PACKAGING SPECIFICATIONS

<Taping packaging specifications>

- Taping version is packaged in 500 pcs. per reel. Orders will be accepted for units of 500 pcs., i.e., 500, 1000, 1500 pcs., etc.
- Taping version is boxed with one reel (500 pcs.).

Maximum number of consecutive missing pieces=2
 Leader length and reel dimension are shown in the diagrams below.

EMBOSSED TAPE DIMENSIONS

REEL DIMENSIONS

(Unit: mm)

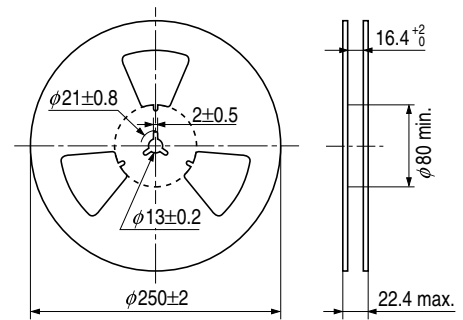
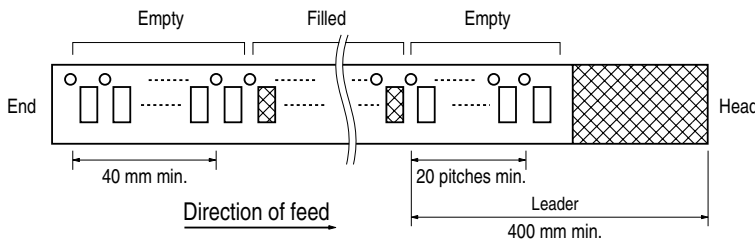

Reel & embossed tape materials

Embossed tape: Plastic
 Reel: Paper

Embossed tape pull strength

9.8 N {1kgf} minimum

Peeling strength of seal tape

0.098~0.69 N {10~70gf}

Test method for peeling strength of seal tape

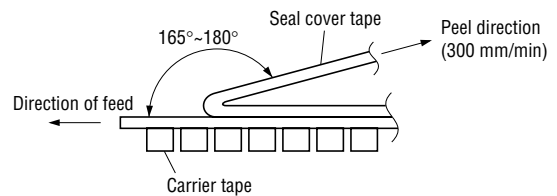

{ } : Reference only

ST-7TA

ST-7TB

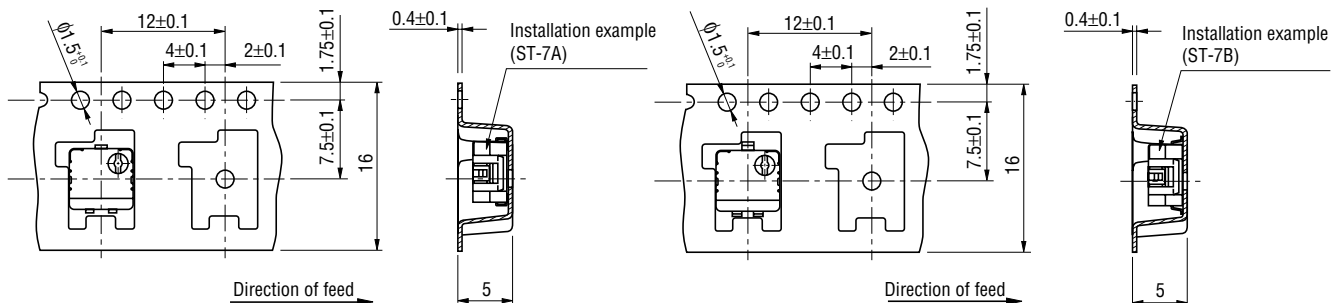

<Bulk packaging specifications>

- Unit of bulk in vinyl bag packaging is 50 pcs. per pack.
- Boxing of bulk in vinyl bags is performed with 200 pcs. per box.

单击下面可查看定价，库存，交付和生命周期等信息

[>>Vishay\(威世\)](#)