

SOT-227 Power Module High Side Chopper - Power MOSFET, 100 A

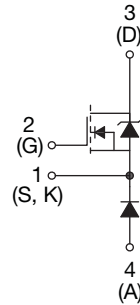

SOT-227

FEATURES
MOSFET

- Enhanced body diode dV/dt and dI_F/dt capability
- Improved gate avalanche and dynamic dV/dt ruggedness
- Fully characterized capacitance and avalanche SOA
- Fully isolated package
- Easy to use and parallel
- Low on-resistance
- Simple drive requirements

**RoHS
COMPLIANT**
CHOPPER DIODE

- Low forward voltage drop
- Ultrafast, soft reverse recovery, with high operating junction temperature ($T_J \text{ max.} = 175^\circ\text{C}$)
- UL approved file E78996
- Material categorization: for definitions of compliance please see www.vishay.com/doc?99912

PRIMARY CHARACTERISTICS	
MOSFET	
V_{DSS}	200 V
$R_{DS(on)}$	9.6 m Ω
I_D at 97 °C	80 A
Type	Modules - MOSFET
Package	SOT-227
CHOPPER DIODE	
I_F at 90 °C	64 A
t_{rr}	33 ns

ABSOLUTE MAXIMUM RATINGS				
PARAMETER	SYMBOL	TEST CONDITIONS	MAX.	UNITS
MOSFET				
Drain to source voltage	V_{DSS}		200	V
Continuous drain current V_{GS} at 10 V	I_D	$T_C = 25^\circ\text{C}$	108	A
		$T_C = 90^\circ\text{C}$	83	
Pulsed drain current	$I_{DM}^{(1)}$		170	
Power dissipation	P_D	$T_C = 25^\circ\text{C}$	405	W
		$T_C = 90^\circ\text{C}$	229	
Gate to source voltage	V_{GS}		± 30	V
Single pulse avalanche energy	$E_{AS}^{(2)}$		600	mJ
Avalanche current	$I_{AR}^{(3)}$		50	A
Repetitive avalanche energy	$E_{AR}^{(3)}$		300	mJ
CHOPPER DIODE				
Cathode to anode voltage	V_R		200	V
Continuous forward current	I_F	$T_C = 25^\circ\text{C}$	92	A
		$T_C = 90^\circ\text{C}$	64	
Maximum peak one cycle non-repetitive surge current	I_{FSM}		280	A
Maximum power dissipation, chopper diode	P_D	$T_C = 90^\circ\text{C}$	79	W
MODULE				
Operating junction temperature range	T_J		-55 to +175	°C
Storage temperature range	T_{Stg}		-55 to +175	
RMS insulation voltage	V_{ISO}	Any terminal to case, $t = 1 \text{ min}$	2500	V

Notes

- (1) Repetitive rating; pulse width limited by maximum junction temperature starting $T_J = 25^\circ\text{C}$
- (2) Limited by $T_J \text{ max.}$, starting $T_J = 25^\circ\text{C}$, $L = 0.23 \text{ mH}$, $R_g = 25 \Omega$, $I_{AS} = 72 \text{ A}$, $V_{GS} = 10 \text{ V}$. Part not recommended for use above this value
- (3) Repetitive rating; pulse width limited by maximum junction temperature starting $T_J = 25^\circ\text{C}$, $L = 0.23 \text{ mH}$, $R_g = 25 \Omega$, $V_{GS} = 10 \text{ V}$, duty cycle 1 %



THERMAL - MECHANICAL SPECIFICATIONS							
PARAMETER		SYMBOL		MIN.	TYP.	MAX.	UNITS
Junction to case thermal resistance	MOSFET	R _{thJC}		-	-	0.37	°C/W
	Chopper Diode			-	-	1.08	
Case to sink, flat greased surface (heatsink compound thermal conductivity = 1 W/mK)	Module	R _{thCS}		-	0.10	-	
Mounting torque			Torque to terminal	-	-	1.1 (9.7)	Nm (lbf.in)
			Torque to heatsink	-	-	1.8 (15.9)	Nm (lbf.in)
Approximate module weight				-	30	-	g

ELECTRICAL CHARACTERISTICS (T _J = 25 °C unless otherwise specified)							
PARAMETER	SYMBOL	TEST CONDITIONS	MIN.	TYP.	MAX.	UNITS	
MOSFET							
Drain-to-source breakdown voltage	V _{(BR)DSS}	V _{GS} = 0 V, I _D = 500 μA	200	-	-	V	
Breakdown voltage temperature coefficient	ΔV _{(BR)DSS} /ΔT _J	Reference to 25 °C, I _D = 1 mA	-	0.21	-	V/°C	
Static drain-to-source on-resistance	R _{DS(on)} ⁽¹⁾	V _{GS} = 10 V, I _D = 80 A	-	9.6	14.0	mΩ	
Gate threshold voltage	V _{GS(th)}	V _{DS} = V _{GS} , I _D = 250 μA	2.7	4.1	5.5	V	
		V _{DS} = V _{GS} , I _D = 250 μA, T _J = 125 °C	-	2.6	-		
Forward transconductance	g _{fs}	V _{DS} = 20 V, I _D = 80 A	-	200	-	S	
Drain-to-source leakage current	I _{DSS}	V _{DS} = 200 V, V _{GS} = 0 V	-	0.6	25	μA	
		V _{DS} = 200 V, V _{GS} = 0 V, T _J = 125 °C	-	20	500		
		V _{DS} = 200 V, V _{GS} = 0 V, T _J = 175 °C	-	1	5	mA	
Gate-to-source forward leakage	I _{GSS}	V _{GS} = 20 V	-	-	120	nA	
Gate-to-source reverse leakage		V _{GS} = -20 V	-	-	-120		
Total gate charge	Q _g	I _D = 80 A, V _{DS} = 100 V, V _{GS} = 10 V, see fig. 15 and fig. 28 ⁽¹⁾	-	161	-	nC	
Gate-to-source charge	Q _{gs}		-	54	-		
Gate-to-drain ("Miller") charge	Q _{gd}		-	52	-		
Turn-on delay time	t _{d(on)}	V _{DD} = 100 V, I _D = 80 A, R _g = 2.5 Ω, L = 500 μH	-	148	-	ns	
Rise time	t _r		-	215	-		
Turn-off delay time	t _{d(off)}		-	114	-		
Fall time	t _f		-	125	-		
Turn-on delay time	t _{d(on)}	V _{DD} = 100 V, I _D = 80 A, R _g = 2.5 Ω, L = 500 μH, T _J = 125 °C	-	132	-	ns	
Rise time	t _r		-	215	-		
Turn-off delay time	t _{d(off)}		-	124	-		
Fall time	t _f		-	108	-		
Internal source inductance	L _S	Between lead and center of die contact	-	3	-	nH	
Input capacitance	C _{iss}	V _{GS} = 0 V, V _{DS} = 50 V, f = 1.0 MHz, see fig. 14	-	10 720	-	pF	
	C _{oss}		-	810	-		
	C _{rss}		-	160	-		
Drain to Case Capacitance	C _{d-cs}	V _{GS} = 0 V, (G-S shorted); f = 1 MHz	-	50	-		
CHOPPER DIODE							
Diode reverse breakdown voltage	V _{BR}	I _R = 100 μA	200	-	-	V	
Forward voltage drop	V _{FM}	I _F = 30 A	-	0.94	1.08		
		I _F = 30 A, T _J = 125 °C	-	0.8	-		
		I _F = 30 A, T _J = 175 °C	-	0.74	-		
Reverse leakage current	I _{RM}	V _R = V _R rated	-	1	50	μA	
		V _R = V _R rated, T _J = 125 °C	-	7	-		
		V _R = V _R rated, T _J = 175 °C	-	0.15	1	mA	
Junction capacitance	C _T	V _R = 200 V	-	119	-	pF	

Note

⁽¹⁾ Pulse width ≤ 400 μs, duty cycle ≤ 2 %



SOURCE-DRAIN RATINGS AND CHARACTERISTICS (T _J = 25 °C unless otherwise specified)						
PARAMETER	SYMBOL	TEST CONDITIONS	MIN.	TYP.	MAX.	UNITS
MOSFET						
Continuous source current (body diode)	I _S	MOSFET symbol showing the integral reverse p-n junction diode	-	-	108	A
Pulsed source current (body diode)	I _{SM} ⁽¹⁾		-	-	170	
Body diode forward voltage	V _{SD} ⁽²⁾	T _J = 25 °C, I _S = 80 A, V _{GS} = 0 V	-	0.88	1.02	V
		T _J = 125 °C, I _S = 80 A, V _{GS} = 0 V	-	0.76	-	
		T _J = 175 °C, I _S = 80 A, V _{GS} = 0 V	-	0.70	-	
Reverse recovery time	t _{rr}	T _J = 25 °C, I _F = 30 A, dI _F /dt = 100 A/μs, V _R = 100 V ⁽²⁾	-	145	-	ns
Reverse recovery current	I _{rr}		-	11	-	A
Reverse recovery charge	Q _{rr}		-	790	-	nC
Reverse recovery time	t _{rr}	T _J = 125 °C, I _F = 30 A, dI _F /dt = 100 A/μs, V _R = 100 V ⁽²⁾	-	170	-	ns
Reverse recovery current	I _{rr}		-	13.5	-	A
Reverse recovery charge	Q _{rr}		-	1140	-	nC
Forward turn-on time	t _{on}	Intrinsic turn-on time is negligible (turn-on is dominated by LS + LD)				

DYNAMIC RECOVERY CHARACTERISTICS (T _J = 25 °C unless otherwise specified)						
PARAMETER	SYMBOL	TEST CONDITIONS	MIN.	TYP.	MAX.	UNITS
CHOPPER DIODE						
Reverse recovery time	t _{rr}	T _J = 25 °C, I _F = 30 A, dI _F /dt = 200 A/μs, V _R = 100 V ⁽²⁾	-	33	-	ns
Reverse recovery current	I _{rr}		-	3.5	-	A
Reverse recovery charge	Q _{rr}		-	59	-	nC
Reverse recovery time	t _{rr}	T _J = 125 °C, I _F = 30 A, dI _F /dt = 200 A/μs, V _R = 100 V ⁽²⁾	-	59	-	ns
Reverse recovery current	I _{rr}		-	8.3	-	A
Reverse recovery charge	Q _{rr}		-	238	-	nC

Notes

- (1) Repetitive rating, pulse width limited by maximum junction temperature (see fig. 27)
- (2) Pulse width ≤ 300 μs, duty cycle ≤ 2 %

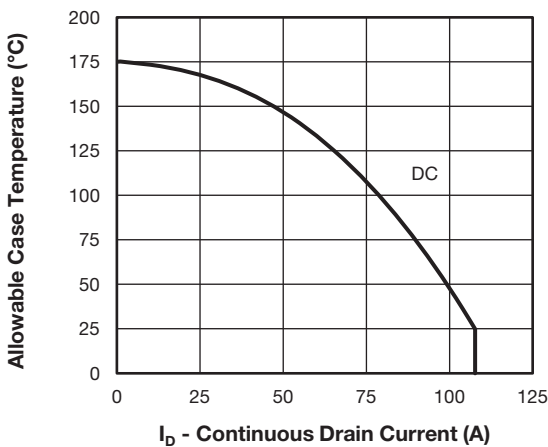

Fig. 1 - Maximum MOSFET Drain-Source Current vs. Case Temperature

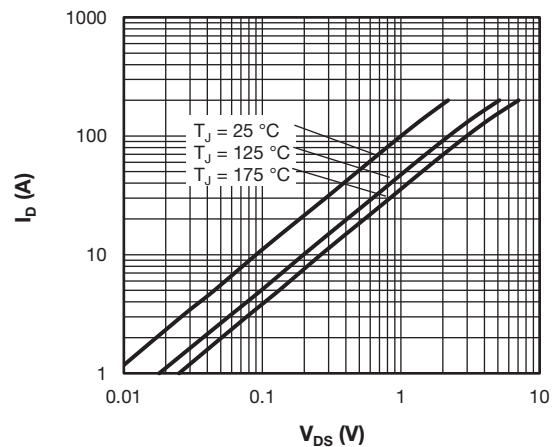

Fig. 2 - Typical MOSFET Output Characteristics, V_{GS} = 10 V

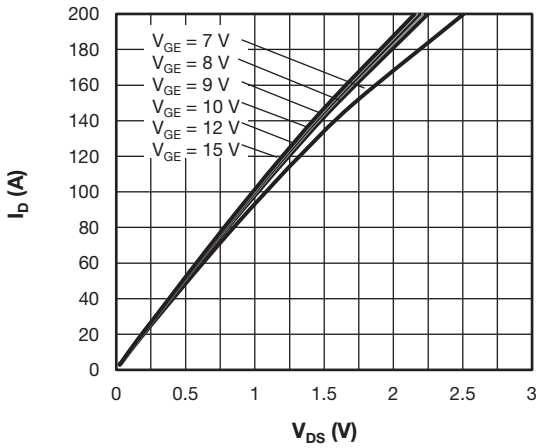

Fig. 3 - Typical MOSFET Output Characteristics, at $T_J = 25\text{ }^\circ\text{C}$

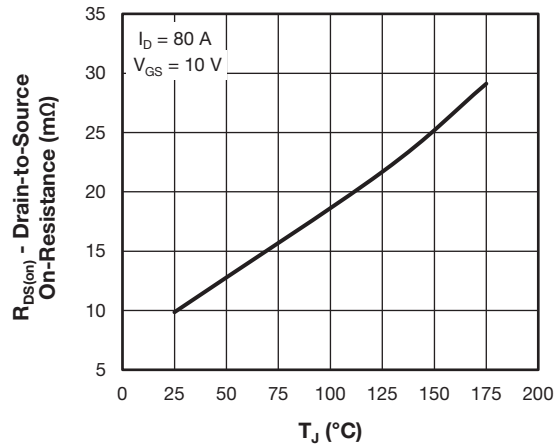

Fig. 6 - Typical Drain to Source On-Resistance vs. Temperature

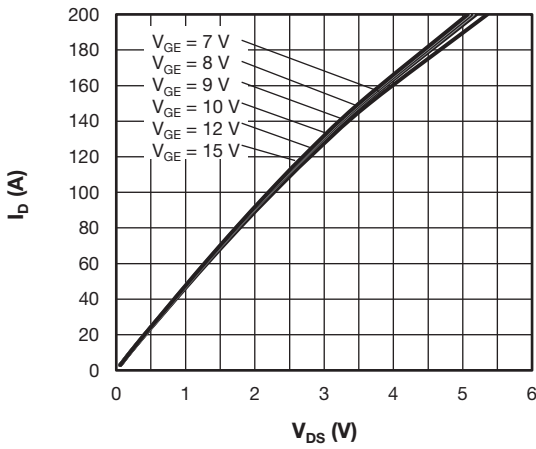

Fig. 4 - Typical MOSFET Output Characteristics, at $T_J = 125\text{ }^\circ\text{C}$

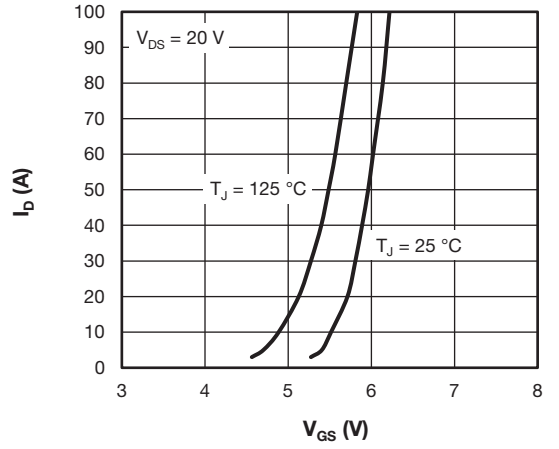

Fig. 7 - Typical MOSFET Transfer Characteristics

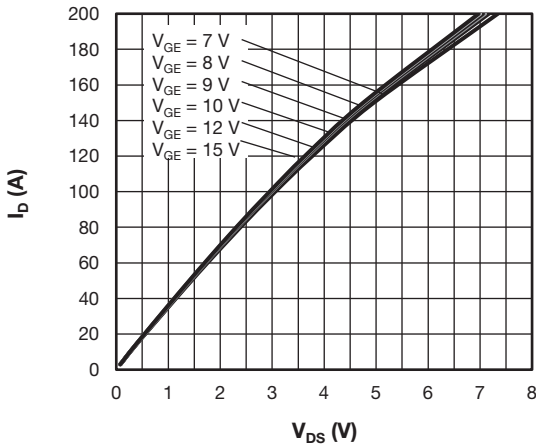

Fig. 5 - Typical MOSFET Output Characteristics, at $T_J = 175\text{ }^\circ\text{C}$

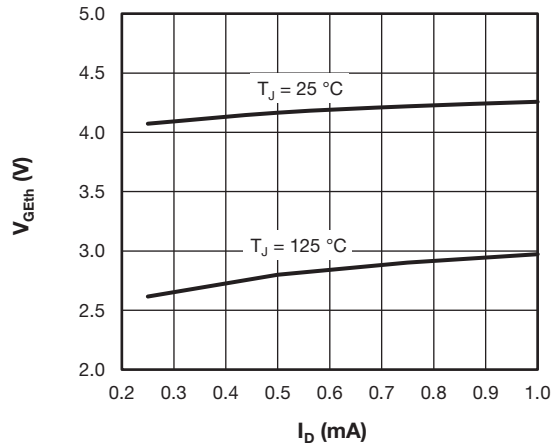

Fig. 8 - Typical MOSFET Gate Threshold Voltage

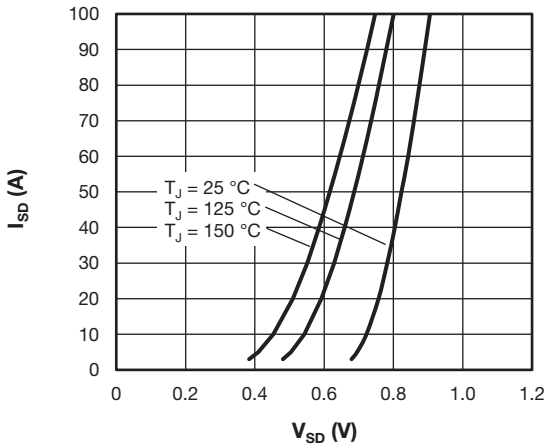

Fig. 9 - Typical MOSFET Body Diode Forward Current Characteristics

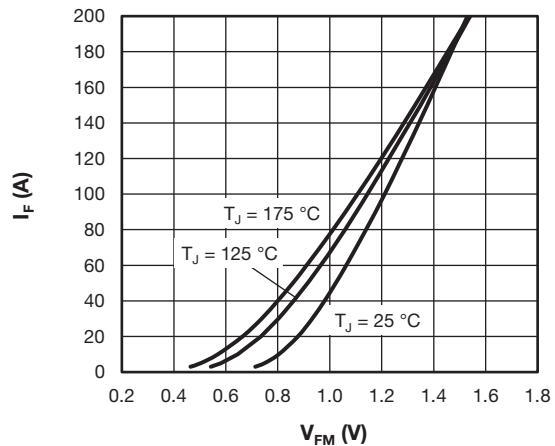

Fig. 12 - Typical Chopper Diode Forward Characteristics

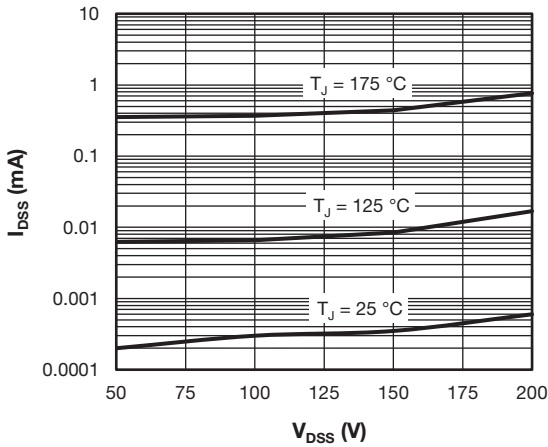

Fig. 10 - Typical MOSFET Zero Gate Voltage Drain Current

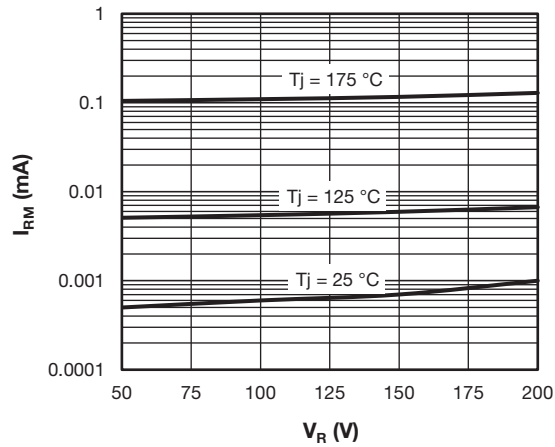

Fig. 13 - Typical Chopper Diode Reverse Leakage Current

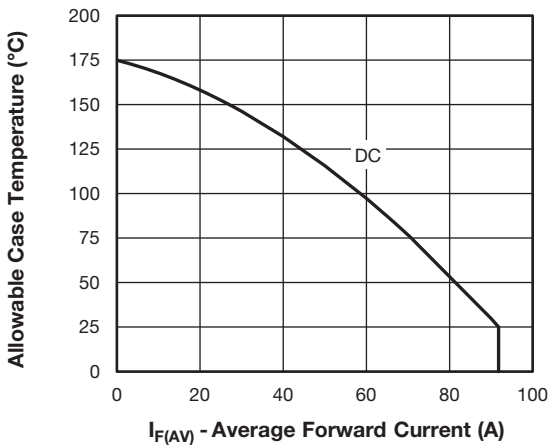

Fig. 11 - Maximum Allowable Forward Current vs. Case Temperature

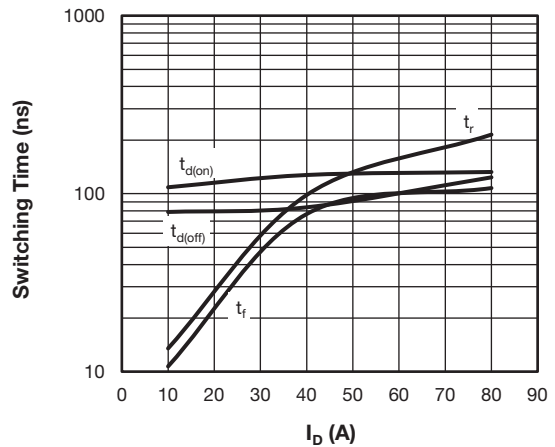

Fig. 14 - Typical MOSFET Switching Time vs. I_D
 $T_J = 125\text{ }^\circ\text{C}$, $V_{DD} = 100\text{ V}$, $R_g = 2.5\text{ }\Omega$, $V_{GS} = 10\text{ V}$, $L = 500\text{ }\mu\text{H}$

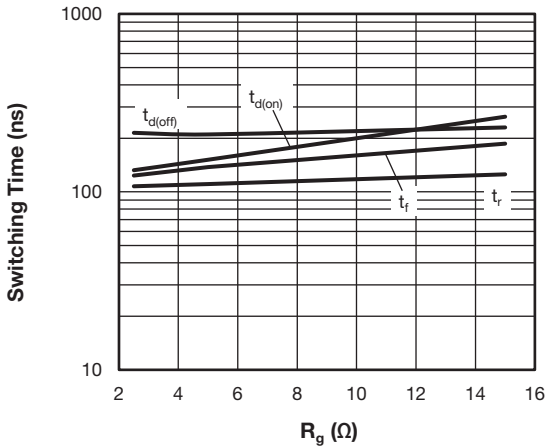

Fig. 15 - Typical MOSFET Switching Time vs. R_g
 $T_J = 125^\circ\text{C}$, $V_{DD} = 100\text{ V}$, $I_D = 80\text{ A}$, $L = 500\ \mu\text{H}$

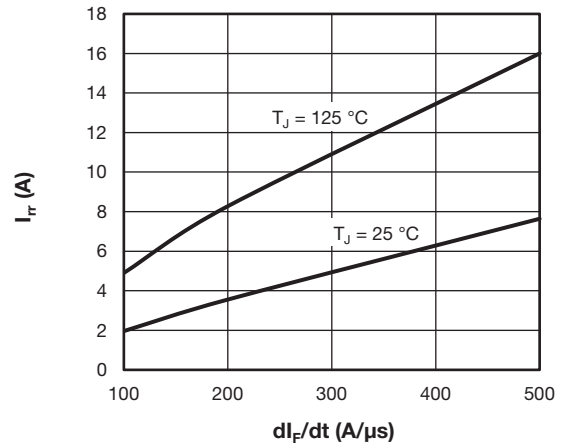

Fig. 17 - Typical Chopper Diode Reverse Recovery Current vs. di_F/dt
 $V_{rr} = 100\text{ V}$, $I_F = 30\text{ A}$

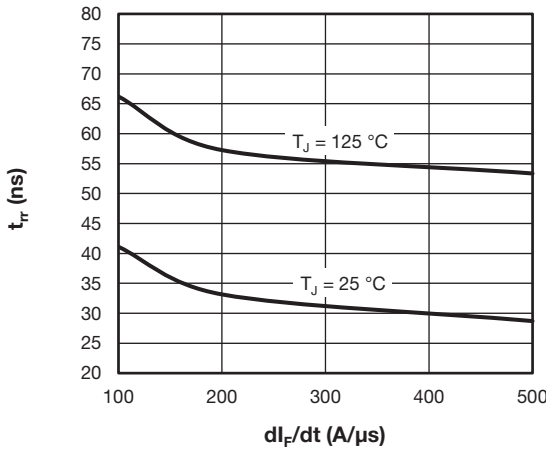

Fig. 16 - Typical Chopper Diode Reverse Recovery Time vs. di_F/dt
 $V_{rr} = 100\text{ V}$, $I_F = 30\text{ A}$

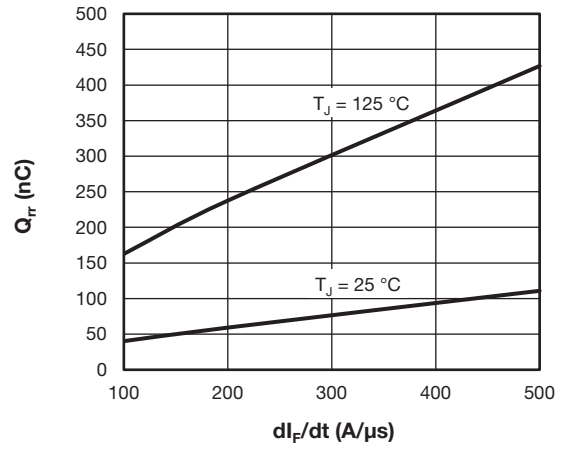

Fig. 18 - Typical Chopper Diode Reverse Recovery Charge vs. di_F/dt
 $V_{rr} = 100\text{ V}$, $I_F = 30\text{ A}$

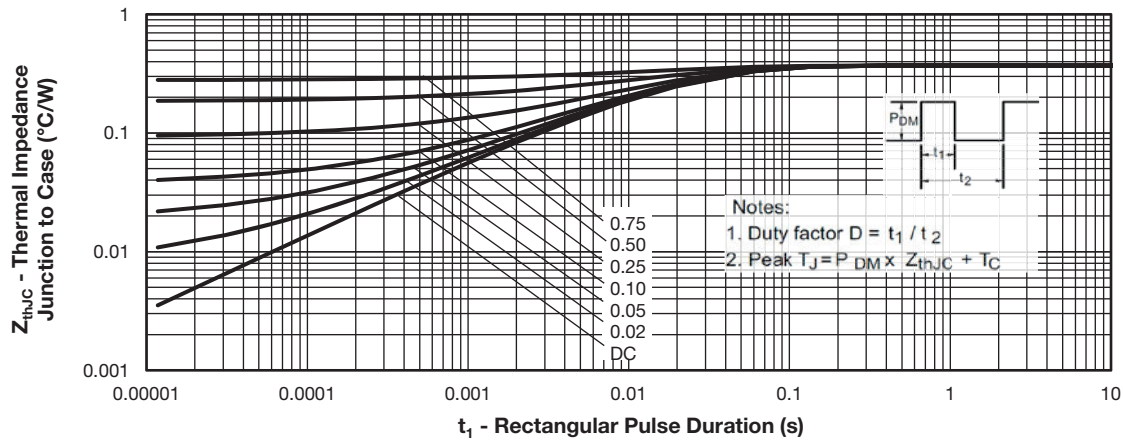

Fig. 19 - Maximum Thermal Impedance Z_{thJC} Characteristics - (MOSFET)

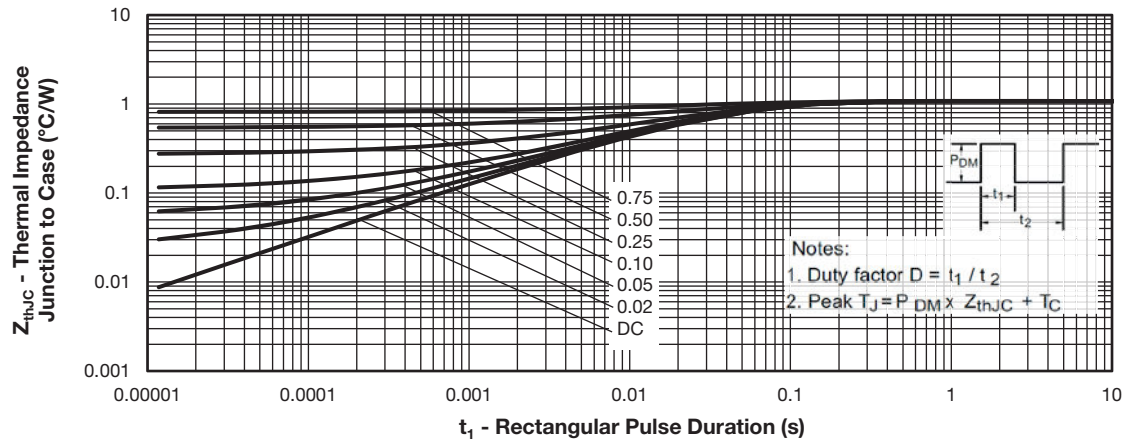
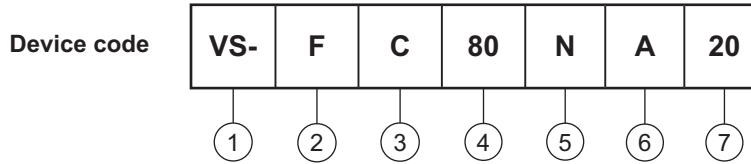

Fig. 20 - Maximum Thermal Impedance Characteristics (Chopper Diode)

CIRCUIT CONFIGURATION		
CIRCUIT	CIRCUIT CONFIGURATION CODE	CIRCUIT DRAWING
High side chopper	N	



ORDERING INFORMATION TABLE



- 1** - Vishay Semiconductors product
- 2** - MOSFET module
- 3** - MOSFET die generation
- 4** - Current rating (80 = 80 A)
- 5** - N = high side chopper
- 6** - Package indicator SOT-227
- 7** - Voltage rating (20 = 200 V)

LINKS TO RELATED DOCUMENTS	
Dimensions	www.vishay.com/doc?95423
Packaging information	www.vishay.com/doc?95425



SOT-227 Generation 2

DIMENSIONS in millimeters (inches)

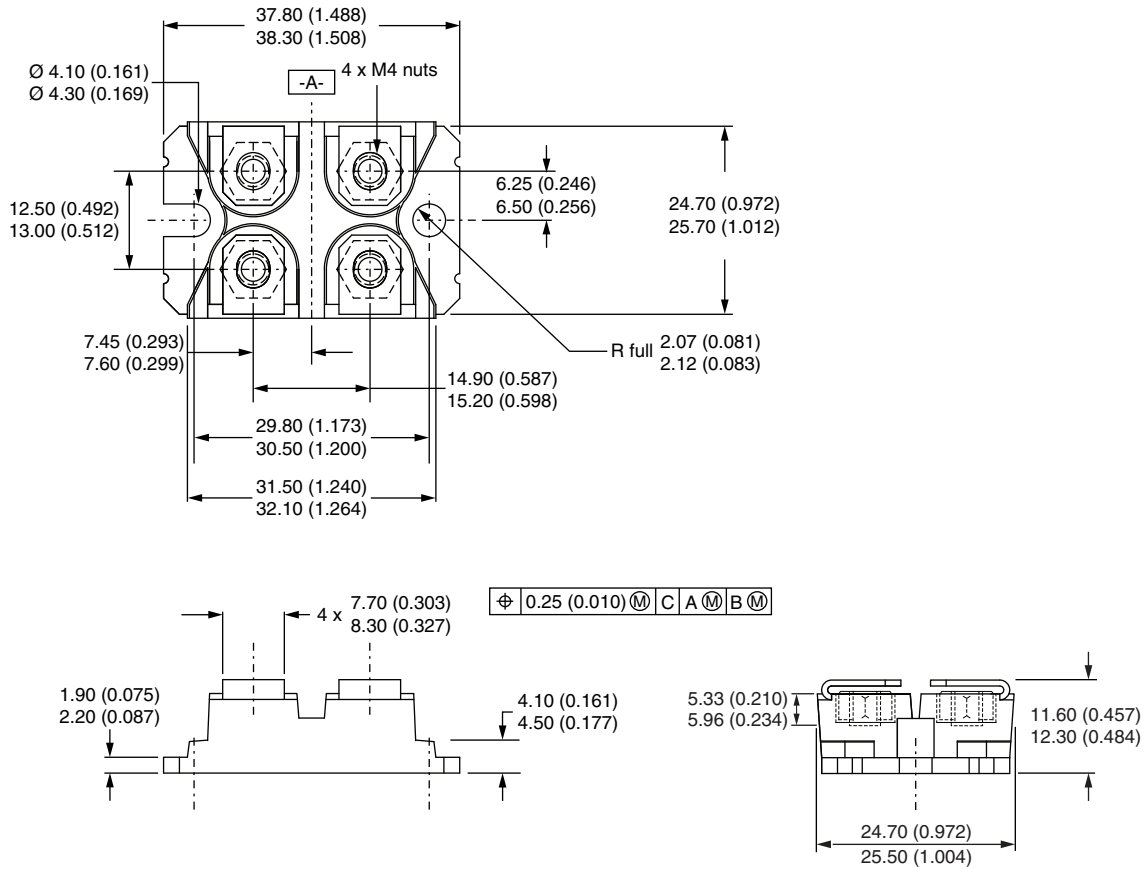

Note

- Controlling dimension: millimeter



Disclaimer

ALL PRODUCT, PRODUCT SPECIFICATIONS AND DATA ARE SUBJECT TO CHANGE WITHOUT NOTICE TO IMPROVE RELIABILITY, FUNCTION OR DESIGN OR OTHERWISE.

Vishay Intertechnology, Inc., its affiliates, agents, and employees, and all persons acting on its or their behalf (collectively, "Vishay"), disclaim any and all liability for any errors, inaccuracies or incompleteness contained in any datasheet or in any other disclosure relating to any product.

Vishay makes no warranty, representation or guarantee regarding the suitability of the products for any particular purpose or the continuing production of any product. To the maximum extent permitted by applicable law, Vishay disclaims (i) any and all liability arising out of the application or use of any product, (ii) any and all liability, including without limitation special, consequential or incidental damages, and (iii) any and all implied warranties, including warranties of fitness for particular purpose, non-infringement and merchantability.

Statements regarding the suitability of products for certain types of applications are based on Vishay's knowledge of typical requirements that are often placed on Vishay products in generic applications. Such statements are not binding statements about the suitability of products for a particular application. It is the customer's responsibility to validate that a particular product with the properties described in the product specification is suitable for use in a particular application. Parameters provided in datasheets and / or specifications may vary in different applications and performance may vary over time. All operating parameters, including typical parameters, must be validated for each customer application by the customer's technical experts. Product specifications do not expand or otherwise modify Vishay's terms and conditions of purchase, including but not limited to the warranty expressed therein.

Hyperlinks included in this datasheet may direct users to third-party websites. These links are provided as a convenience and for informational purposes only. Inclusion of these hyperlinks does not constitute an endorsement or an approval by Vishay of any of the products, services or opinions of the corporation, organization or individual associated with the third-party website. Vishay disclaims any and all liability and bears no responsibility for the accuracy, legality or content of the third-party website or for that of subsequent links.

Except as expressly indicated in writing, Vishay products are not designed for use in medical, life-saving, or life-sustaining applications or for any other application in which the failure of the Vishay product could result in personal injury or death. Customers using or selling Vishay products not expressly indicated for use in such applications do so at their own risk. Please contact authorized Vishay personnel to obtain written terms and conditions regarding products designed for such applications.

No license, express or implied, by estoppel or otherwise, to any intellectual property rights is granted by this document or by any conduct of Vishay. Product names and markings noted herein may be trademarks of their respective owners.

单击下面可查看定价，库存，交付和生命周期等信息

[>>Vishay\(威世\)](#)