

microBUCK® SiC403

6 A, 28 V Integrated Buck Regulator with Programmable LDO

DESCRIPTION

The Vishay Siliconix SiC403 is an advanced stand-alone synchronous buck regulator featuring integrated power MOSFETs, bootstrap switch, and a programmable LDO in a space-saving MLPQ 5 x 5 - 32 pin package.

The SiC403 is capable of operating with all ceramic solutions and switching frequencies up to 1 MHz. The programmable frequency, synchronous operation and selectable power-save allow operation at high efficiency across the full range of load current. The internal LDO may be used to supply 5 V for the gate drive circuits or it may be bypassed with an external 5 V for optimum efficiency and used to drive external n-channel MOSFETs or other loads. Additional features include cycle-by-cycle current limit, voltage soft-start, under-voltage protection, programmable over-current protection, soft shutdown and selectable power-save. The Vishay Siliconix SiC403 also provides an enable input and a power good output.

FEATURES

- High efficiency > 95 %
- 6 A continuous output current capability
- Integrated bootstrap switch
- Programmable 200 mA LDO with bypass logic
- Temperature compensated current limit
- Pseudo fixed-frequency adaptive on-time control
- All ceramic solution enabled
- Programmable input UVLO threshold
- Independent enable pin for switcher and LDO
- Selectable ultra-sonic power-save mode
- Programmable soft-start
- Soft-shutdown
- 1 % internal reference voltage
- Power good output
- Under and over voltage protection
- Material categorization: For definitions of compliance please see www.vishay.com/doc?99912



PRODUCT SUMMARY	
Input Voltage Range	3 V to 28 V
Output Voltage Range	0.75 V to 5.5 V
Operating Frequency	200 kHz to 1 MHz
Continuous Output Current	6 A
Peak Efficiency	95 % at 300 kHz
Package	MLPQ 5 mm x 5 mm

APPLICATIONS

- Notebook, desktop, and server computers
- Digital HDTV and digital consumer applications
- Networking and telecommunication equipment
- Printers, DSL, and STB applications
- Embedded applications
- Point of load power supplies

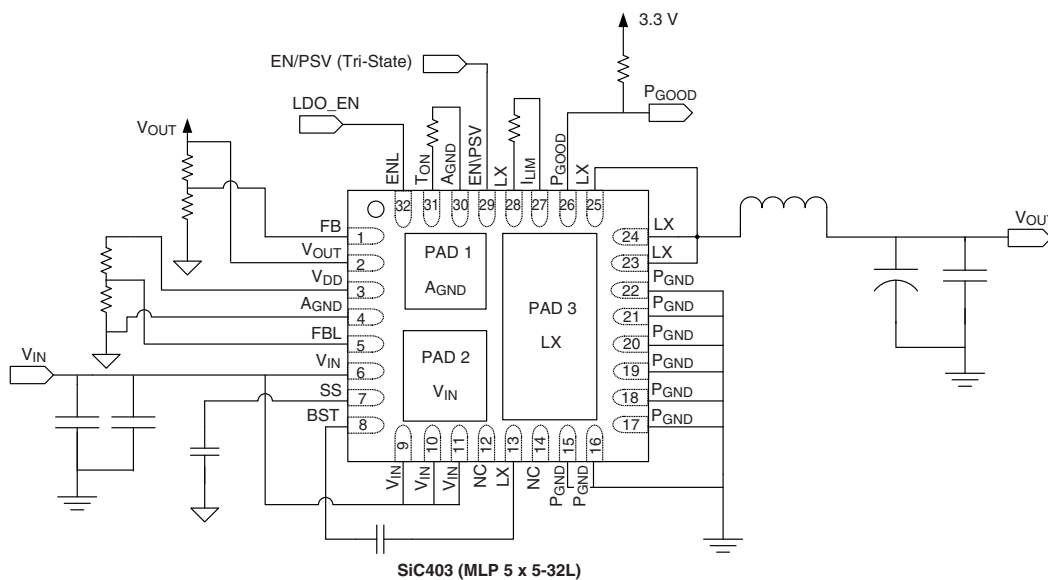
TYPICAL APPLICATION CIRCUIT

THERMAL RESISTANCE RATINGS

Parameter	Symbol	Min.	Typ.	Max.	Unit
Thermal Resistance, Junction-to-Ambient ^b					
High-Side MOSFET			25		°C/W
Low-Side MOSFET			20		
PWM Controller and LDO Thermal Resistance			50		
Peak IR Reflow Temperature	T _{Reflow}	-		260	°C

Notes:

- a. This device is ESD sensitive. Use of standard ESD handling precautions is required.
 b. Calculated from package in still air, mounted to 3 x 4.5 (in), 4 layer FR4 PCB with thermal vias under the exposed pad per JE51 standards.

Exceeding the above specifications may result in permanent damage to the device or device malfunction. Operation outside of the parameters specified in the Electrical Characteristics section is not recommended.

ELECTRICAL SPECIFICATIONS

Parameter	Symbol	Test Conditions Unless Specified V _{IN} = 12 V, V _{DD} = 5 V, T _A = +25 °C for typ., -40 °C to +85 °C for min. and max., T _J = < 125 °C	Min.	Typ.	Max.	Unit
Input Supplies						
V _{IN} UVLO Threshold Voltage ^a	V _{IN_UV+}	Sensed at ENL pin, rising edge	2.4	2.6	2.95	V
	V _{IN_UV-}	Sensed at ENL pin, falling edge	2.235	2.4	2.565	
V _{IN} UVLO Hysteresis	V _{IN_UV_HY}	EN/PSV = High		0.2		
V _{DD} UVLO Threshold Voltage	V _{DD_UV+}	Measured at V _{DD} pin, rising edge	2.5	2.8	3	
	V _{DD_UV-}	Measured at V _{DD} pin, falling edge	2.4	2.6	2.9	
V _{DD} UVLO Hysteresis	V _{DD_UV_HY}			0.2		
V _{IN} Supply Current	I _{IN}	EN/PSV, ENL = 0 V, V _{IN} = 28 V		8.5	20	µA
		Standby mode: ENL = V _{DD} , EN/PSV = 0 V		130		
V _{DD} Supply Current	I _{VDD}	EN/PSV, ENL = 0 V		3	7	mA
		EN/PSV = V _{DD} , no load (f _{SW} = 25 kHz), V _{FB} > 750 mV		2		
		f _{SW} = 250 kHz, EN/PSV = floating, no load ^b 25°C bench testing		10		
Controller						
FB On-Time Threshold	V _{FB-TH}	Static V _{IN} and load, -40 °C to +85 °C	0.7425	0.750	0.7599	V
Frequency Range ^b	F _{PWM}	continuous mode, 25°C bench testing	200		1000	kHz
Bootstrap Switch Resistance				10		Ω
Timing						
On-Time	t _{ON}	Continuous mode operation V _{IN} = 15 V, V _{OUT} = 5 V, R _{ton} = 300 kΩ	2386	2650	2915	ns
Minimum On-Time ^b	t _{ON}	25°C bench testing		80		
Minimum Off-Time ^b	t _{OFF}	25°C bench testing		320		
Soft Start						
Soft Start Current ^b	I _{SS}	I _{OUT} = I _{LIM} /2, 25°C bench testing		2.75		µA
Analog Inputs/Outputs						
V _{OUT} Input Resistance	R _{O-IN}			500		kΩ
Current Sense						
Zero-Crossing Detector Threshold Voltage	V _{Sense-th}	LX-P _{GND}	-3.5	0.5	+3.5	mV
Power Good						
Power Good Threshold Voltage	PG_V _{TH_UPPER}	V _{FB} > internal reference 750 mV		+20		%
Power Good Threshold Voltage	PG_V _{TH_LOWER}	V _{FB} < internal reference 750 mV		-10		
Start-Up Delay Time	PG_T _d	C _{SS} = 10 nF		12		ms
Fault (noise-immunity) Delay Time ^b	PG_I _{CC}	V _{EN} = 0 V, 25°C bench testing		5		µs
Power Good Leakage Current	PG_I _{LK}	V _{EN} = 0 V			1	µA
Power Good On-Resistance	PG_R _{DS-ON}	V _{EN} = 0 V		10		Ω



ELECTRICAL SPECIFICATIONS						
Parameter	Symbol	Test Conditions Unless Specified $V_{IN} = 12\text{ V}, V_{DD} = 5\text{ V}, T_A = +25\text{ }^\circ\text{C}$ for typ., $-40\text{ }^\circ\text{C}$ to $+85\text{ }^\circ\text{C}$ for min. and max., $T_J = < 125\text{ }^\circ\text{C}$	Min.	Typ.	Max.	Unit
Fault Protection						
I_{LIM} Source Current	I_{LIM}			8		μA
Valley Current Limit		$R_{ILIM} = 6\text{ k}\Omega, V_{DD} = 5\text{ V},$ 25°C bench testing	4.5	6	7.2	A
Output Under-Voltage Fault	V_{OUV_Fault}	V_{FB} with respect to Internal 500 mV reference, 8 consecutive clocks		-25		%
Smart Power-Save Protection Threshold Voltage ^b	P_{SAVE_VTH}	V_{FB} with respect to internal 500 mV reference, 25°C bench testing		+10		%
Over-Voltage Protection Threshold		V_{FB} with respect to internal 500 mV reference		+20		
Over-Voltage Fault Delay ^b	$t_{OV-Delay}$	25°C bench testing		5		μs
Over Temperature Shutdown ^b	T_{Shut}	10 °C hysteresis, 25°C bench testing		150		°C
Logic Inputs/Outputs						
Logic Input High Voltage	V_{IH}	EN, ENL, PSV	1			V
Logic Input Low Voltage	V_{IL}				0.4	
EN/PSV Input Bias Current	I_{EN}	EN/PSV = V_{DD} or A_{GND}	-10		+10	μA
ENL Input Bias Current	I_{ENL}	$V_{IN} = 28\text{ V}$		11	18	
FBL, FB Input Bias Current	FBL_I_{LK}	FBL, FB = V_{DD} or A_{GND}	-1		+1	
Linear Dropout Regulator						
FBL Accuracy	FBL_{ACC}	V_{LDO} load = 10 mA	0.735	0.750	0.765	V
LDO Current Limit	LDO_I_{LIM}	Start-up and foldback, $V_{IN} = 12\text{ V}$		115		mA
		Operating current limit, $V_{IN} = 12\text{ V}$	134	200		
V_{LDO} to V_{OUT} Switch-Over Threshold ^c	$V_{LDO-BPS}$		-130		+130	mV
V_{LDO} to V_{OUT} Non-Switch-Over Threshold ^c	$V_{LDO-NBPS}$		-500		+500	
V_{LDO} to V_{OUT} Switch-Over Resistance	R_{LDO}	$V_{OUT} = 5\text{ V}$		2		Ω
LDO Drop Out Voltage ^d		From V_{IN} to V_{VLDO} , $V_{VLDO} = +5\text{ V},$ $I_{VLDO} = 100\text{ mA}$		1.2		V

Notes:

- a. $V_{IN\ UVLO}$ is programmable using a resistor divider from V_{IN} to ENL to A_{GND} . The ENL voltage is compared to an internal reference.
- b. Guaranteed by design.
- c. The switch-over threshold is the maximum voltage differential between the V_{LDO} and V_{OUT} pins which ensures that V_{LDO} will internally switch-over to V_{OUT} . The non-switch-over threshold is the minimum voltage differential between the V_{LDO} and V_{OUT} pins which ensures that V_{LDO} will not switch-over to V_{OUT} .
- d. The LDO drop out voltage is the voltage at which the LDO output drops 2 % below the nominal regulation point.

ELECTRICAL CHARACTERISTICS

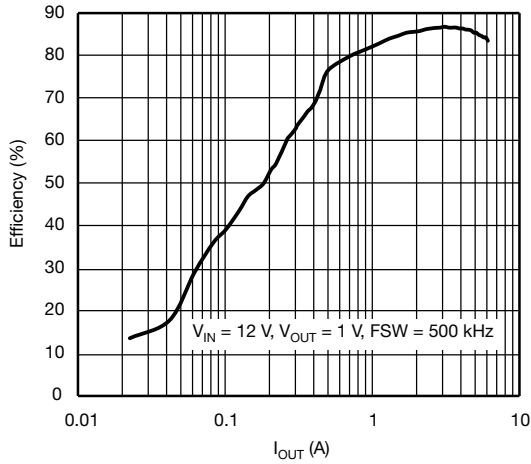

Efficiency vs. I_{OUT}
(in Continuous Conduction Mode)

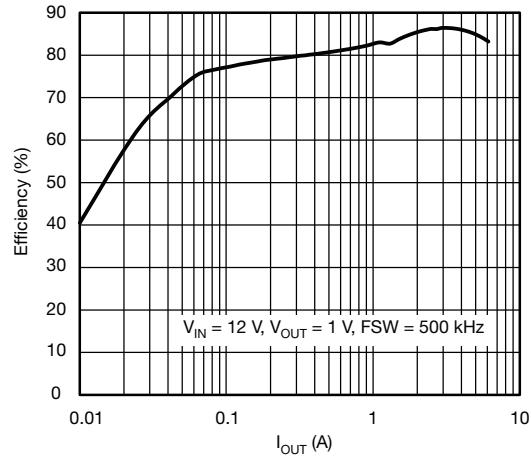

Efficiency vs. I_{OUT}
(in Power-Save-Mode)

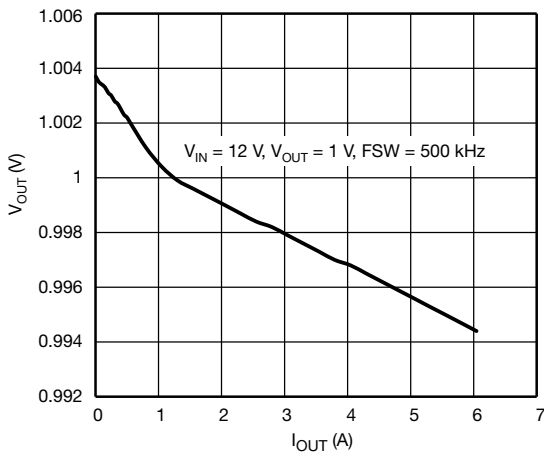

V_{OUT} vs. I_{OUT}
(in Continuous Conduction Mode)

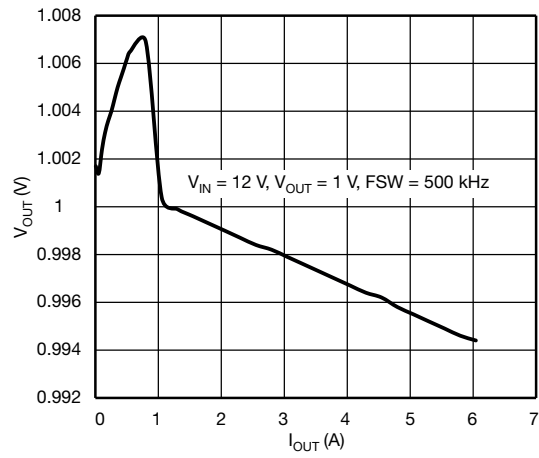

V_{OUT} vs. I_{OUT}
(in Power-Save-Mode)

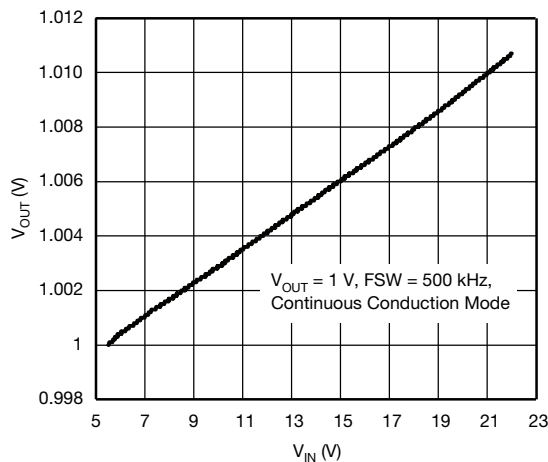

V_{OUT} vs. V_{IN} at $I_{OUT} = 0$ A
(in Continuous Conduction Mode, FSW = 500 kHz)

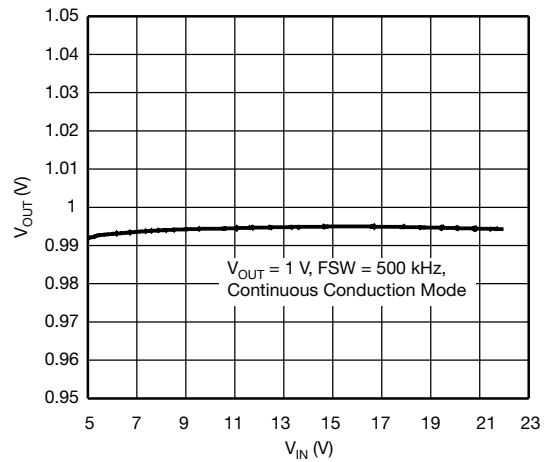

V_{OUT} vs. V_{IN} at $I_{OUT} = 6$ A
(in Continuous Conduction Mode, FSW = 500 kHz)

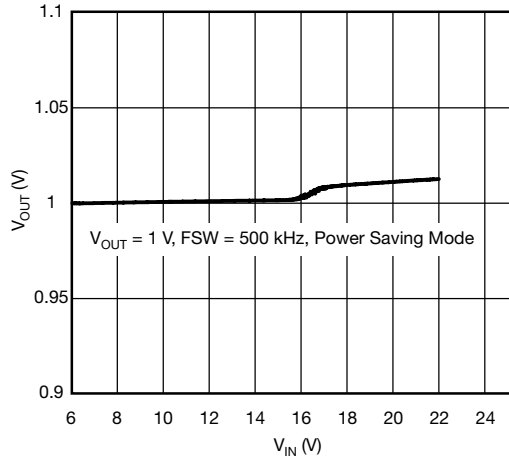
ELECTRICAL CHARACTERISTICS

V_{OUT} vs. V_{IN}
($I_{OUT} = 0\text{ A}$ in Power-Save-Mode)

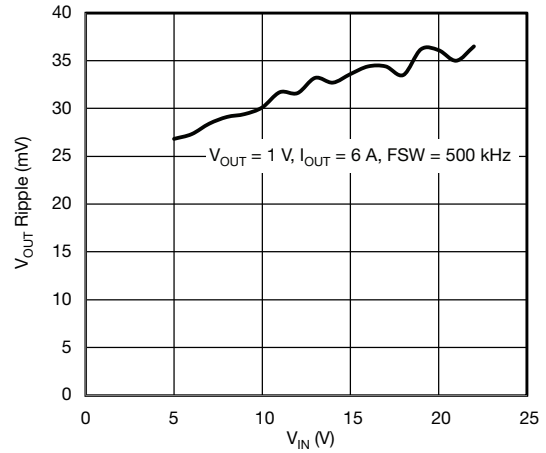

V_{OUT} Ripple vs. V_{IN}
($I_{OUT} = 6\text{ A}$ in Continuous Conduction Mode)

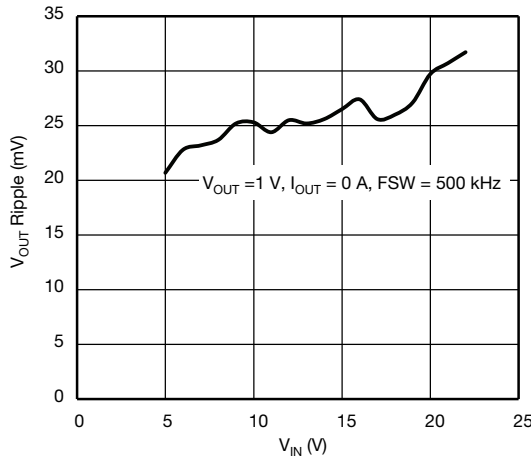

V_{OUT} Ripple vs. V_{IN}
($I_{OUT} = 0\text{ A}$ in Continuous Conduction Mode)

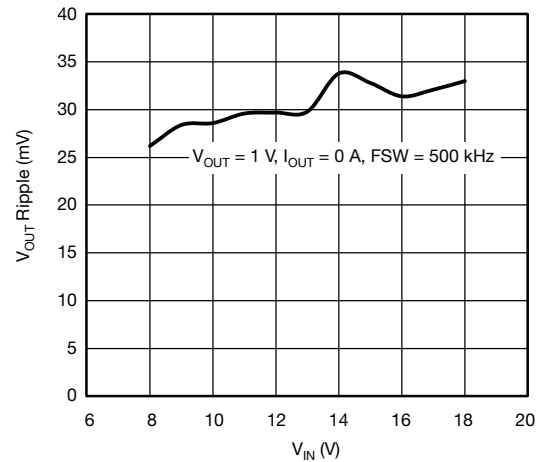

V_{OUT} Ripple vs. V_{IN}
($I_{OUT} = 0\text{ A}$ in Power-Save-Mode)

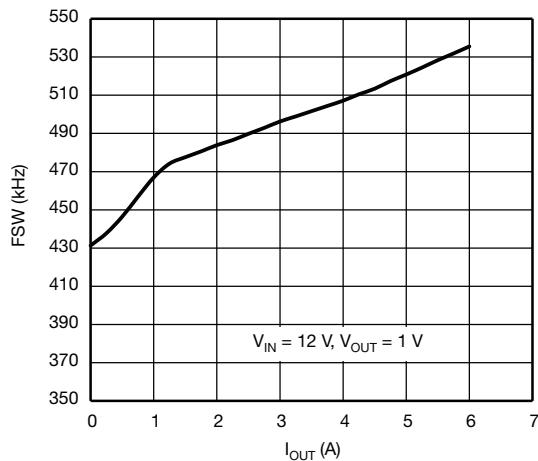

FSW vs. I_{OUT}
(in Continuous Conduction Mode)

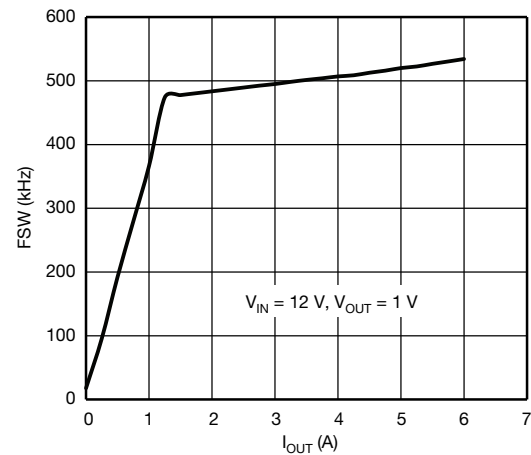

FSW vs. I_{OUT}
(in Power-Save-Mode)

ELECTRICAL CHARACTERISTICS

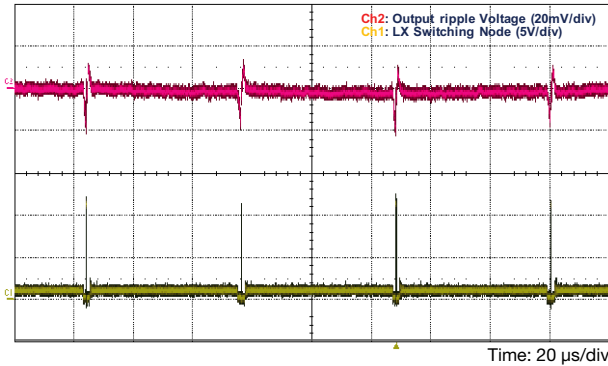

V_{OUT} Ripple in Power Save Mode (No Load)
 (V_{IN} = 12 V, V_{OUT} = 1 V)

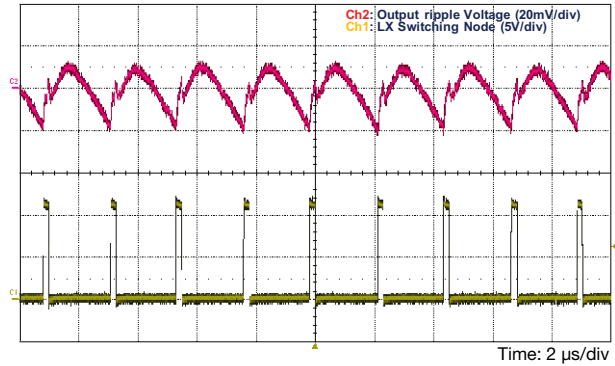

V_{OUT} Ripple in Continuous Conduction Mode (No Load)
 (V_{IN} = 12 V, V_{OUT} = 1 V, FSW = 500 kHz)

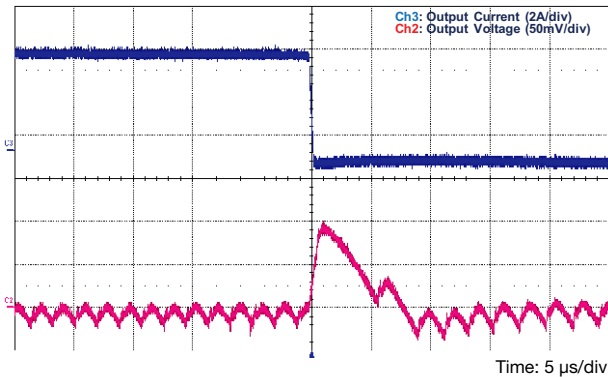

Transient Response in Continuous Conduction Mode
 (6 A to 0.2 A)
 (V_{IN} = 12 V, V_{OUT} = 1 V, FSW = 500 kHz)

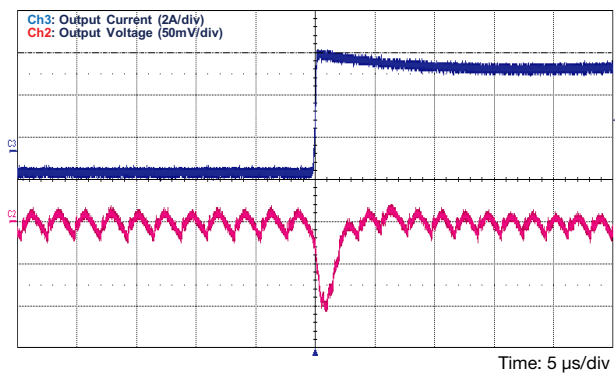

Transient Response in Continuous Conduction Mode
 (0.2 A to 6 A)
 (V_{IN} = 12 V, V_{OUT} = 1 V, FSW = 500 kHz)

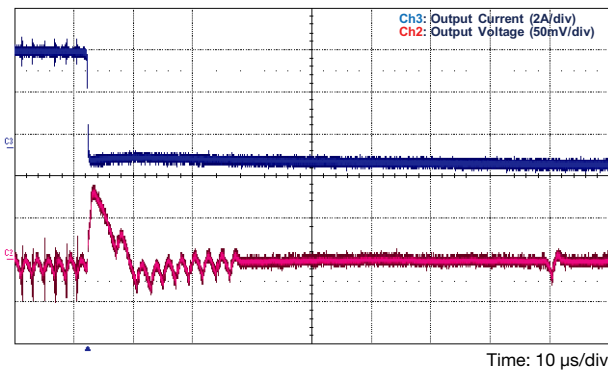

Transient Response in Power Save Mode
 (6 A to 0.2 A)
 (V_{IN} = 12 V, V_{OUT} = 1 V, FSW = 500 kHz at 6 A)

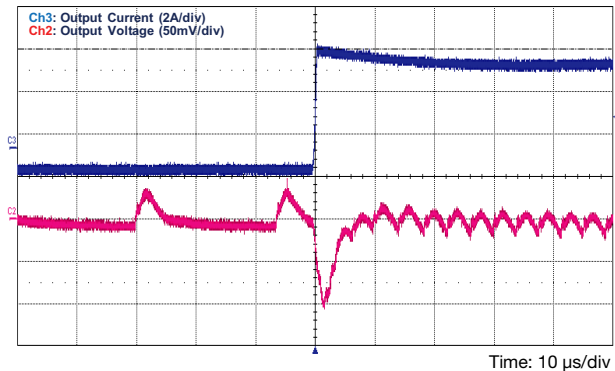

Transient Response in Power Save Mode
 (0.2 A to 6 A)
 (V_{IN} = 12 V, V_{OUT} = 1 V, FSW = 500 kHz at 6 A)

ELECTRICAL CHARACTERISTICS

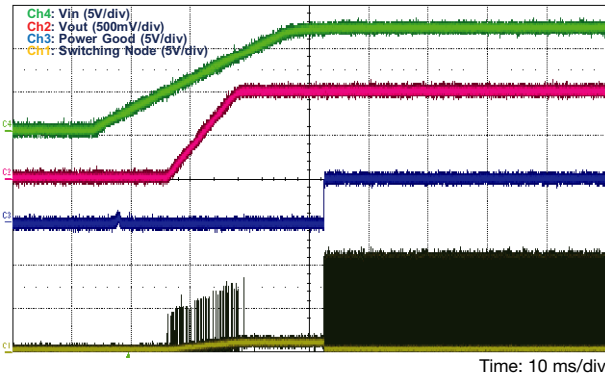

Start-up with V_{IN} Ramping up
($V_{IN} = 12\text{ V}$, $V_{OUT} = 1\text{ V}$, FSW = 500 kHz)

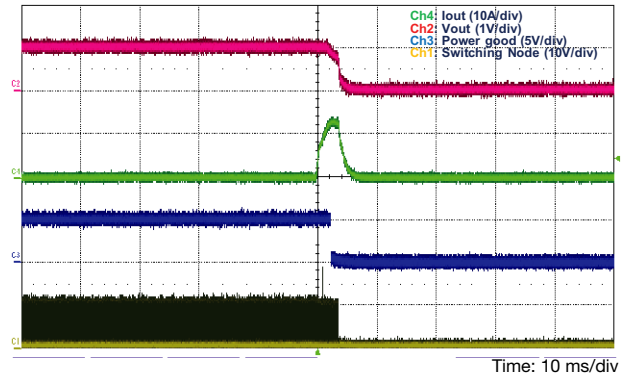

Over-Current Protection
($V_{IN} = 12\text{ V}$, $V_{OUT} = 1\text{ V}$, FSW = 500 kHz)

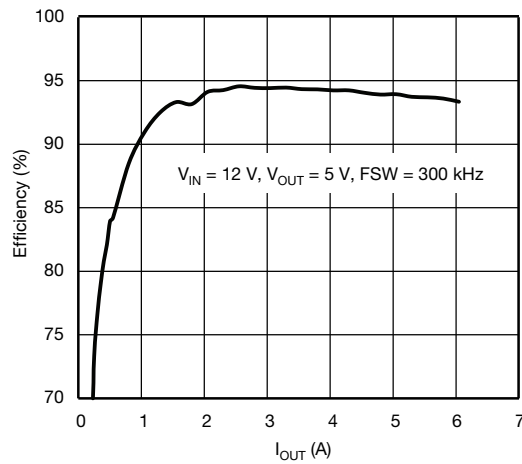

Efficiency with 12 V_{IN} , 5 V_{OUT} , 300 kHz

APPLICATIONS INFORMATION

SiC403 Synchronous Buck Converter

The SiC403 is a step down synchronous buck DC/DC converter with integrated power FETs and programmable LDO. The SiC403 is capable of 6 A operation at very high efficiency in a tiny 5 mm x 5 mm - 32 pin package. The programmable operating frequency range of 200 kHz to 1 MHz, enables the user to optimize the solution for minimum board space and optimum efficiency.

The buck controller employs pseudo-fixed frequency adaptive on-time control. This control scheme allows fast transient response thereby lowering the size of the power components used in the system.

Input Voltage Range

The SiC403 requires two input supplies for normal operation: V_{IN} and V_{DD} . V_{IN} operates over the wide range from 3 V to 28 V. V_{DD} requires a supply voltage between 3 V to 5 V that can be an external source or the internal LDO configured from V_{IN} .

Power Up Sequence

The SiC403 initiates a start up when V_{IN} , V_{DD} , and EN/PSV pins are above the applicable thresholds. When using an external bias supply for the V_{DD} voltage, it is recommended that the V_{DD} is applied to the device only after the V_{IN} voltage is present because V_{DD} cannot exceed V_{IN} at any time. A 10 resistor must be placed between the external V_{DD} supply and the V_{DD} pin to avoid damage to the device during power-up and or shutdown situations where V_{DD} could exceed V_{IN} unexpectedly.

Shut-Down

The SiC403 can be shut-down by pulling either V_{DD} or EN/PSV pin below its threshold. When using an external supply voltage for V_{DD} , the V_{DD} pin must be deactivated while the V_{IN} voltage is still present. A 10 resistor must be placed between the external V_{DD} supply and the V_{DD} pin to avoid damage to the device.

When the V_{DD} pin is active and EN/PSV is at low logic level, the output voltage discharges through an internal FET.

Pseudo-Fixed Frequency Adaptive On-Time Control

The PWM control method used for the SiC403 is pseudo-fixed frequency, adaptive on-time, as shown in figure 1. The ripple voltage generated at the output capacitor ESR is used as a PWM ramp signal. This ripple is used to trigger the on-time of the controller.

The adaptive on-time is determined by an internal oneshot timer. When the one-shot is triggered by the output ripple, the device sends a single on-time pulse to the highside MOSFET. The pulse period is determined by V_{OUT} and V_{IN} ; the period is proportional to output voltage and inversely proportional to input voltage. With this adaptive on-time arrangement, the device automatically anticipates the on-time needed to regulate V_{OUT} for the present V_{IN} condition and at the selected frequency.

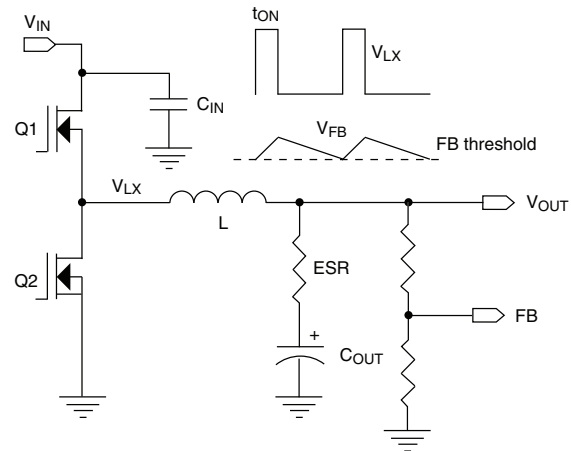

Figure 1 - Output Ripple and PWM Control Method

The adaptive on-time control has significant advantages over traditional control methods used in the controllers today.

- Reduced component count by eliminating DCR sense or current sense resistor as no need of a sensing inductor current.
- Reduced saves external components used for compensation by eliminating the no error amplifier and other components.
- Ultra fast transient response because of fast loop, absence of error amplifier speeds up the transient response.
- Predictable frequency spread because of constant on-time architecture.
- Fast transient response enables operation with minimum output capacitance

Overall, superior performance compared to fixed frequency architectures.

On-Time One-Shot Generator (t_{ON}) and Operating Frequency

The SiC403 have an internal on-time one-shot generator which is a comparator that has two inputs. The FB Comparator output goes high when V_{FB} is less than the internal 750 mV reference. This feeds into the gate drive and turns on the high-side MOSFET, and also starts the one-shot timer. The one-shot timer uses an internal comparator and a capacitor. One comparator input is connected to V_{OUT} , the other input is connected to the capacitor. When the on-time begins, the internal capacitor charges from zero volts through a current which is proportional to V_{IN} . When the capacitor voltage reaches V_{OUT} , the on-time is completed and the high-side MOSFET turns off. The figure 2 shows the on-chip implementation of on-time generation.

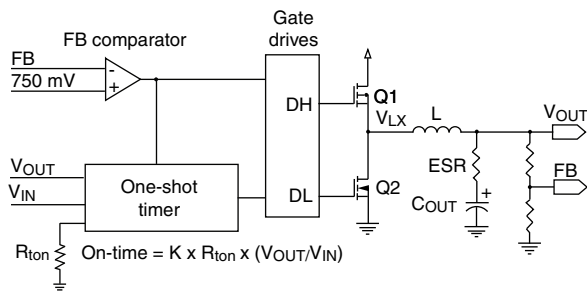
Figure 2 - On-Time Generation

This method automatically produces an on-time that is proportional to V_{OUT} and inversely proportional to V_{IN} .

Under steady-state conditions, the switching frequency can be determined from the on-time by the following equation.

$$f_{sw} = \frac{V_{OUT}}{t_{ON} \times V_{IN}}$$

The SiC403 uses an external resistor to set the ontime which indirectly sets the frequency. The on-time can be programmed to provide operating frequency from 200 kHz to 1 MHz using a resistor between the t_{ON} pin and ground. The resistor value is selected by the following equation.

$$R_{ton} = \frac{(t_{ON} - 10 \text{ ns}) \times V_{IN}}{25 \text{ pF} \times V_{OUT}}$$

The maximum R_{ton} value allowed is shown by the following equation.

$$R_{ton_MAX} = \frac{V_{IN_MIN}}{15 \mu A}$$

V_{OUT} Voltage Selection

The switcher output voltage is regulated by comparing V_{OUT} as seen through a resistor divider at the FB pin to the internal 750 mV reference voltage, see figure 3.

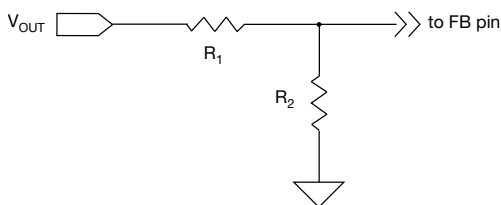
Figure 3 - Output Voltage Selection

As the control method regulates the valley of the output ripple voltage, the DC output voltage V_{OUT} is off set by the output ripple according to the following equation.

$$V_{OUT} = 0.75 \times \left(1 + \frac{R_1}{R_2}\right) + \left(\frac{V_{RIPPLE}}{2}\right)$$

When a large capacitor is placed in parallel with R_1 (C_{TOP}) V_{OUT} is shown by the following equation.

$$V_{OUT} = 0.75 \times \left(1 + \frac{R_1}{R_2}\right) + \left(\frac{V_{RIPPLE}}{2}\right) \times \sqrt{\frac{1 + (R_1 \omega C_{TOP})^2}{1 + \left(\frac{R_2 \times R_1}{R_2 + R_1} \omega C_{TOP}\right)^2}}$$

Enable and Power-Save Inputs

The EN/PSV and ENL inputs are used to enable or disable the switching regulator and the LDO.

When EN/PSV is low (grounded), the switching regulator is off and in its lowest power state. When off, the output of the switching regulator soft-discharges the output into a 15 Ω internal resistor via the V_{OUT} pin.

When EN/PSV is allowed to float, the pin voltage will float to 1.5 V. The switching regulator turns on with power-save disabled and all switching is in forced continuous mode.

When EN/PSV is high (above 2 V), the switching regulator turns on with ultra-sonic power-save enabled. The SiC403 ultra-sonic power-save operation maintains a minimum switching frequency of 25 kHz, for applications with stringent audio requirements.

The ENL input is used to control the internal LDO. This input serves a second function by acting as a V_{IN} UVLO sensor for the switching regulator.

The LDO is off when ENL is low (grounded). When ENL is a logic high but below the V_{IN} UVLO threshold (2.6 V typical), then the LDO is on and the switcher is off. When ENL is above the V_{IN} UVLO threshold, the LDO is enabled and the switcher is also enabled if the EN/PSV pin is not grounded.

Forced Continuous Mode Operation

The SiC403 operates the switcher in Forced Continuous Mode (FCM) by floating the EN/PSV pin (see figure 4). In this mode one of the power MOSFETs is always on, with no intentional dead time other than to avoid cross-conduction. This feature results in uniform frequency across the full load range with the trade-off being poor efficiency at light loads due to the high-frequency switching of the MOSFETs.

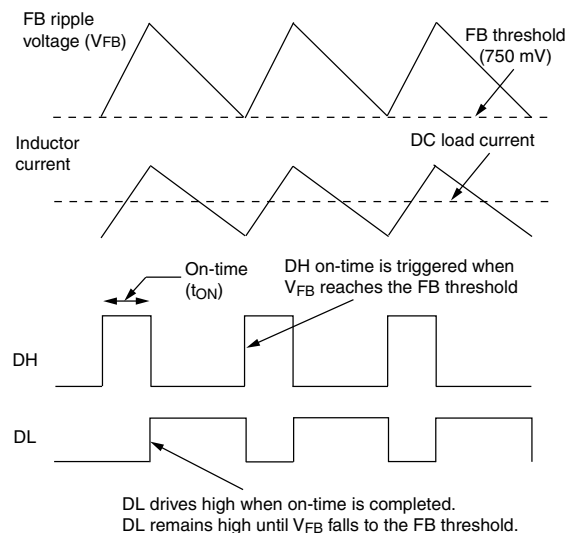
Figure 4 - Forced Continuous Mode Operation

Ultrasonic Power-Save Operation

The SiC403 provides ultra-sonic power-save operation at light loads, with the minimum operating frequency fixed at 25 kHz. This is accomplished using an internal timer that monitors the time between consecutive high-side gate pulses.

If the time exceeds 40 μ s, DL drives high to turn the low-side MOSFET on. This draws current from V_{OUT} through the inductor, forcing both V_{OUT} and V_{FB} to fall. When V_{FB} drops to the 750 mV threshold, the next DH on-time is triggered.

After the on-time is completed the high-side MOSFET is turned off and the low-side MOSFET turns on, the low-side MOSFET remains on until the inductor current ramps down to zero, at which point the low-side MOSFET is turned off.

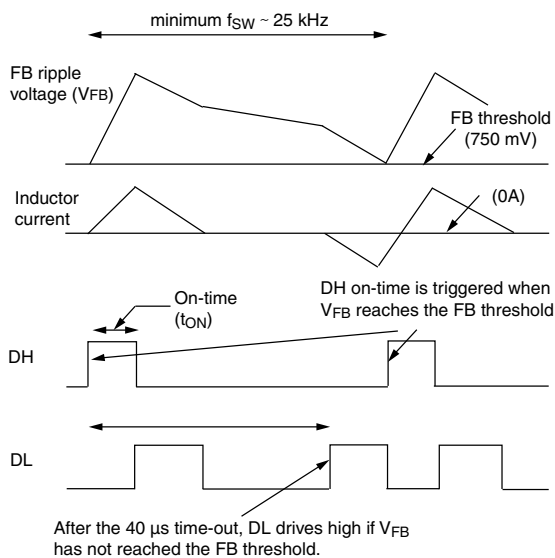

Figure 5 - Ultrasonic power-save Operation

Because the on-times are forced to occur at intervals no greater than 40 μ s, the frequency will not fall below ~ 25 kHz. Figure 5 shows ultra-sonic power-save operation.

Benefits of Ultrasonic Power-Save

Having a fixed minimum frequency in power-save has some significant advantages as below:

- The minimum frequency of 25 kHz is outside the audible range of human ear. This makes the operation of the SiC403 very quiet.
- The output voltage ripple seen in power-save mode is significant lower than conventional power-save, which improves efficiency at light loads.
- Lower ripple in power-save also makes the power component selection easier.

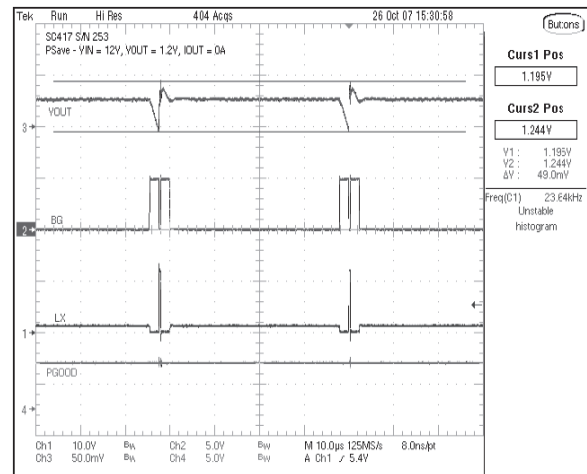

Figure 6 - Ultrasonic Power-Save Operation Mode

Figure 6 shows the behavior under power-save and continuous conduction mode at light loads.

Smart Power-Save Protection

Active loads may leak current from a higher voltage into the switcher output. Under light load conditions with power-save-power-save enabled, this can force V_{OUT} to slowly rise and reach the over-voltage threshold, resulting in a hard shutdown. Smart power-save prevents this condition. When the FB voltage exceeds 10 % above nominal (exceeds 825 mV), the device immediately disables power-save, and DL drives high to turn on the low-side MOSFET. This draws current from V_{OUT} through the inductor and causes V_{OUT} to fall. When V_{FB} drops back to the 750 mV trip point, a normal t_{ON} switching cycle begins.

This method prevents a hard OVP shutdown and also cycles energy from V_{OUT} back to V_{IN} . It also minimizes operating power by avoiding forced conduction mode operation. Figure 7 shows typical waveforms for the smart power-save feature.

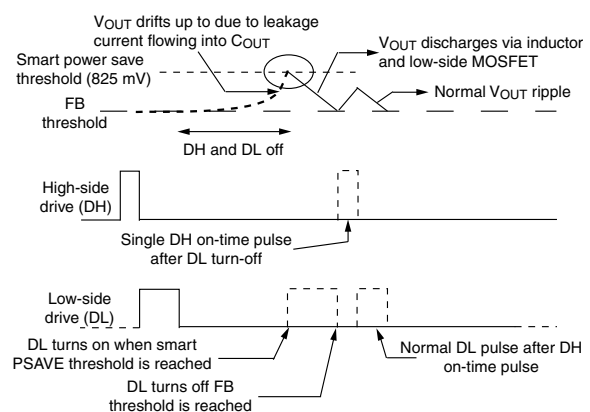

Figure 7 - Smart Power-Save

Current Limit Protection

The SiC403 features programmable current limit capability, which is accomplished by using the $R_{DS(ON)}$ of the lower

MOSFET for current sensing. The current limit is set by R_{ILIM} resistor. The R_{ILIM} resistor connects from the I_{LIM} pin to the LX pin which is also the drain of the low-side MOSFET.

When the low-side MOSFET is on, an internal $\sim 10 \mu\text{A}$ current flows from the I_{LIM} pin and the R_{ILIM} resistor, creating a voltage drop across the resistor. While the low-side MOSFET is on, the inductor current flows through it and creates a voltage across the $R_{DS(ON)}$. The voltage across the MOSFET is negative with respect to ground.

If this MOSFET voltage drop exceeds the voltage across R_{ILIM} , the voltage at the I_{LIM} pin will be negative and current limit will activate. The current limit then keeps the low-side MOSFET on and will not allow another high-side on-time, until the current in the low-side MOSFET reduces enough to bring the I_{LIM} voltage back up to zero. This method regulates the inductor valley current at the level shown by I_{LIM} in figure 8.

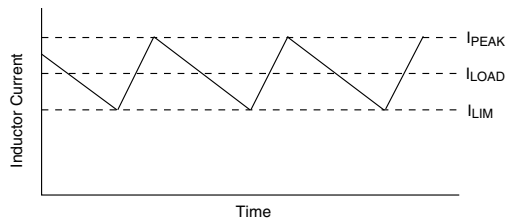

Figure 8 - Valley Current Limit

Setting the valley current limit to 6 A results in a 6 A peak inductor current plus peak ripple current. In this situation, the average (load) current through the inductor is 6 A plus one-half the peak-to-peak ripple current.

The internal $10 \mu\text{A}$ current source is temperature compensated at 4100 ppm in order to provide tracking with the $R_{DS(ON)}$. The R_{ILIM} value is calculated by the following equation.

$$R_{ILIM} = 1176 \times I_{LIM} \times [0.088 \times (5V - V_{DD}) + 1] (\Omega)$$

where I_{LIM} is in A.

When selecting a value for R_{ILIM} do not exceed the absolute maximum voltage value for the I_{LIM} pin.

Note that because the low-side MOSFET with low $R_{DS(ON)}$ is used for current sensing, the PCB layout, solder connections, and PCB connection to the LX node must be done carefully to obtain good results. Refer to the layout guidelines for information.

Soft-Start of PWM Regulator

SiC403 has a programmable soft-start time that is controlled by an external capacitor at the SS pin. After the controller meets both UVLO and EN/PSV thresholds, the controller has an internal current source of $2.75 \mu\text{A}$ flowing through the SS pin to charge the capacitor. During the start up process, 50 % of the voltage at the SS pin is used as the reference for the FB comparator. The PWM comparator issues an on-time

pulse when the voltage at the FB pin is less than 50 % of the SS pin. As result, the output voltage follows the SS start voltage. The output voltage reaches and maintains regulation when the soft start voltage is $> 1.5 \text{ V}$. The time between the first LX pulse and when V_{OUT} meets regulation is the soft start time (t_{SS}). The calculation for the soft-start time is shown by the following equation:

$$t_{SS} = C_{SS} \times \frac{1.5 \text{ V}}{2.75 \mu\text{A}}$$

Power Good Output

The power good (P_{GOOD}) output is an open-drain output which requires a pull-up resistor. When the output voltage is 10 % below the nominal voltage, P_{GOOD} is pulled low. It is held low until the output voltage returns above - 8 % of nominal. P_{GOOD} is held low during start-up and will not be allowed to transition high until soft-start is completed (when V_{FB} reaches 750 mV) and typically 2 ms has passed.

P_{GOOD} will transition low if the V_{FB} pin exceeds + 20 % of nominal, which is also the over-voltage shutdown threshold (900 mV). P_{GOOD} also pulls low if the EN/PSV pin is low when V_{DD} is present.

Output Over-Voltage Protection

Over-voltage protection becomes active as soon as the device is enabled. The threshold is set at $750 \text{ mV} + 20\%$ (900 mV). When V_{FB} exceeds the OVP threshold, DL latches high and the low-side MOSFET is turned on. DL remains high and the controller remains off, until the EN/PSV input is toggled or V_{DD} is cycled. There is a $5 \mu\text{s}$ delay built into the OVP detector to prevent false transitions. P_{GOOD} is also low after an OVP event.

Output Under-Voltage Protection

When V_{FB} falls 25 % below its nominal voltage (falls to 562.5 mV) for eight consecutive clock cycles, the switcher is shut off and the DH and DL drives are pulled low to tristate the MOSFETs. The controller stays off until EN/PSV is toggled or V_{DD} is cycled.

V_{DD} UVLO, and POR

Under-voltage lock-out (UVLO) circuitry inhibits switching and tri-states the DH/DL drivers until V_{DD} rises above 3 V. An internal Power-On Reset (POR) occurs when V_{DD} exceeds 3 V, which resets the fault latch and soft-start counter to prepare for soft-start. The SiC403 then begins a soft-start cycle. The PWM will shut off if V_{DD} falls below 2.4 V.

LDO Regulator

SiC403 has an option to bias the switcher by using an internal LDO from V_{IN} . The LDO output is connected to V_{DD} internally. The output of the LDO is programmable by using external resistors from the V_{DD} pin to A_{GND} . The feedback pin (FBL) for the LDO is regulated to 750 mV (see figure 9).

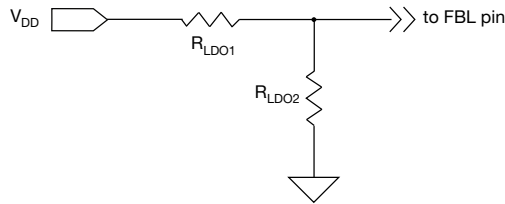

Figure 9 - LDO Voltage Divider

The LDO output voltage is set by the following equation.

$$V_{LDO} = 750 \text{ mV} \times \left(1 + \frac{R_{LDO1}}{R_{LDO2}} \right)$$

A minimum 0.1 μF capacitor referenced to A_{GND} is required along with a minimum 1 μF capacitor referenced to P_{GND} to filter the gate drive pulses. Refer to the layout guidelines section for component placement suggestions.

LDO ENL Functions

The ENL input is used to control the internal LDO. When ENL is low (grounded), the LDO is off. When ENL is above the V_{IN} UVLO threshold, the LDO is enabled and the switcher is also enabled if EN/PSV and V_{DD} meet the thresholds.

The ENL pin also acts as the switcher UVLO (undervoltage lockout) for the V_{IN} supply. The V_{IN} UVLO voltage is programmable via a resistor divider at the V_{IN} , ENL and A_{GND} pins.

If the ENL pin transitions from high to low within 2 switching cycles and is less than 1 V, then the LDO will turn off but the switcher remains on. If the ENL goes below the V_{IN} UVLO threshold and stays above 1 V, then the switcher will turn off but the LDO remains on. The V_{IN} UVLO function has a typical threshold of 2.6 V on the V_{IN} rising edge. The falling edge threshold is 2.4 V.

Note that it is possible to operate the switcher with the LDO disabled, but the ENL pin must be below the logic low threshold (0.4 V max.). In this case, the UVLO function for the input voltage cannot be used. The table below summarizes the function of the ENL and EN pins, with respect to the rising edge of ENL.

EN	ENL	LDO Status	Switcher Status
Low	Low, < 0.4 V	Off	Off
High	Low, < 0.4 V	Off	On
Low	High, < 2.6 V	On	Off
High	High, < 2.6 V	On	Off
Low	High, > 2.6 V	On	Off
High	High, > 2.6 V	On	On

Figure 10 shows the ENL voltage thresholds and their effect on LDO and switcher operation.

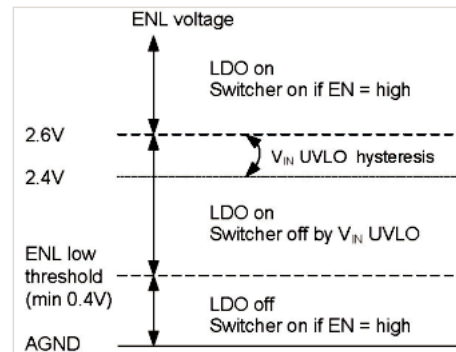

Figure 10 - ENL Threshold

Before start-up, the LDO checks the status of the following signals to ensure proper operation can be maintained.

- ENL pin
- V_{IN} input voltage

When the ENL pin is high and V_{IN} is above the UVLO point, the LDO will begin start-up. During the initial phase, when the V_{DD} voltage (which is the LDO output voltage) is less than 0.75 V, the LDO initiates a current-limited start-up (typically 65 mA) to charge the output capacitors while protecting from a short circuit event. When V_{DD} is greater than 0.75 V but still less than 90 % of its final value (as sensed at the FBL pin), the LDO current limit is increased to ~ 115mA. When V_{DD} has reached 90 % of the final value (as sensed at the FBL pin), the LDO current limit is increased to ~ 200 mA and the LDO output is quickly driven to the nominal value by the internal LDO regulator. It is recommended that during LDO start-up to hold the PWM switching off until the LDO has reached 90 % of the final value. This prevents overloading the current-limited LDO output during the LDO start-up.

Due to the initial current limitations on the LDO during power up (figure 11), any external load attached to the V_{DD} pin must be limited to 20 mA before the LDO has reached 90 % of its final regulation value.

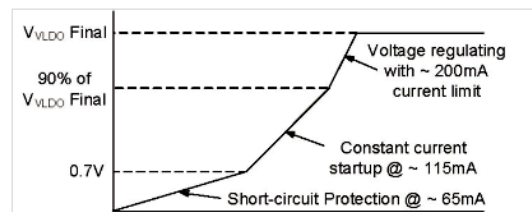

Figure 11 - LDO Start-Up

LDO Switchover Function

The SiC403 includes a switch-over function for the LDO. The switch-over function is designed to increase efficiency by using the more efficient DC/DC converter to power the LDO output, avoiding the less efficient LDO regulator when possible. The switch-over function connects the V_{LDO} pin directly to the V_{OUT} pin using an internal switch. When the switch-over is complete the LDO is turned off, which results

in a power savings and maximizes efficiency. If the LDO output is used to bias the SiC403, then after switch-over the device is self-powered from the switching regulator with the LDO turned off.

The switch-over logic waits for 32 switching cycles before it starts the switch-over. There are two methods that determine the switch-over of V_{LDO} to V_{OUT} .

In the first method, the LDO is already in regulation and the DC/DC converter is later enabled. As soon as the P_{GOOD} output goes high, the 32 cycles are started. The voltages at the V_{LDO} and V_{OUT} pins are then compared; if the two voltages are within ± 300 mV of each other, the V_{LDO} pin connects to the V_{OUT} pin using an internal switch, and the LDO is turned off.

In the second method, the DC/DC converter is already running and the LDO is enabled. In this case the 32 cycles are started as soon as the LDO reaches 90 % of its final value. At this time, the V_{LDO} and V_{OUT} pins are compared, and if within ± 300 mV the switch-over occurs and the LDO is turned off.

Benefits of having a switchover circuit

The switchover function is designed to get maximum efficiency out of the DC/DC converter. The efficiency for an LDO is very low especially for high input voltages. Using the switchover function we tie any rails connected to V_{LDO} through a switch directly to V_{OUT} . Once switchover is complete LDO is turned off which saves power. This gives us the maximum efficiency out of the SiC403.

If the LDO output is used to bias the SiC403, then after switchover the V_{OUT} self biases the SiC403 and operates in self-powered mode.

Steps to follow when using the on chip LDO to bias the SiC403:

- Always tie the V_{DD} to V_{LDO} before enabling the LDO
- Enable the LDO before enabling the switcher
- LDO has a current limit of 40 mA at start-up, so do not connect any load between V_{LDO} and ground
- The current limit for the LDO goes up to 200 mA once the V_{LDO} reaches 90 % of its final values and can easily supply the required bias current to the IC.

Switch-over Limitations on V_{OUT} and V_{LDO}

Because the internal switch-over circuit always compares the V_{OUT} and V_{LDO} pins at start-up, there are limitations on permissible combinations of V_{OUT} and V_{LDO} . Consider the case where V_{OUT} is programmed to 1.5 V and V_{LDO} is programmed to 1.8 V. After start-up, the device would connect V_{OUT} to V_{LDO} and disable the LDO, since the two voltages are within the ± 300 mV switch-over window. To avoid unwanted switch-over, the minimum difference between the voltages for V_{OUT} and V_{LDO} should be ± 500 mV.

It is not recommended to use the switch-over feature for an output voltage less than 3 V since this does not provide sufficient voltage for the gate-source drive to the internal p-channel switch-over MOSFET.

Switch-Over MOSFET Parasitic Diodes

The switch-over MOSFET contains parasitic diodes that are inherent to its construction, as shown in figure 12.

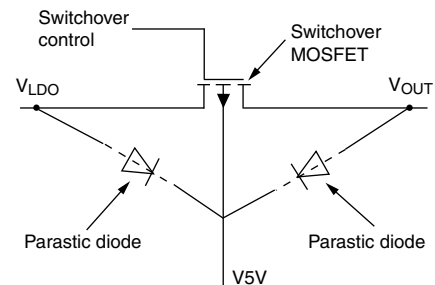

Figure 12- Switch-over MOSFET Parasitic Diodes

There are some important design rules that must be followed to prevent forward bias of these diodes. The following two conditions need to be satisfied in order for the parasitic diodes to stay off.

- $V_{DD} \geq V_{LDO}$
- $V_{DD} \geq V_{OUT}$

If either V_{LDO} or V_{OUT} is higher than V_{DD} , then the respective diode will turn on and the SiC403 operating current will flow through this diode. This has the potential of damaging the device.

ENL Pin and V_{IN} UVLO

The ENL pin also acts as the switcher under-voltage lockout for the V_{IN} supply. The V_{IN} UVLO voltage is programmable via a resistor divider at the V_{IN} , ENL and A_{GND} pins.

ENL is the enable/disable signal for the LDO. In order to implement the V_{IN} UVLO there is also a timing requirement that needs to be satisfied.

If the ENL pin transitions low within 2 switching cycles and is < 0.4 V, then the LDO will turn off but the switcher remains on. If ENL goes below the V_{IN} UVLO threshold and stays above 1 V, then the switcher will turn off but the LDO remains on.

The V_{IN} UVLO function has a typical threshold of 2.6 V on the V_{IN} rising edge. The falling edge threshold is 2.4 V.

Note that it is possible to operate the switcher with the LDO disabled, but the ENL pin must be below the logic low threshold (0.4 V maximum).

ENL Logic Control of PWM Operation

When the ENL input is driven above 2.6 V, it is impossible to determine if the LDO output is going to be used to power the device or not. In self-powered operation where the LDO will power the device, it is necessary during the LDO start-up to hold the PWM switching off until the LDO has reached 90 % of the final value. This is to prevent overloading the

current-limited LDO output during the LDO start-up. However, if the switcher was previously operating (with EN/PSV high but ENL at ground, and V_{DD} supplied externally), then it is undesirable to shut down the switcher.

To prevent this, when the ENL input is taken above 2.6 V (above the V_{IN} UVLO threshold), the internal logic checks the P_{GOOD} signal. If P_{GOOD} is high, then the switcher is already running and the LDO will run through the start-up cycle without affecting the switcher. If P_{GOOD} is low, then the LDO will not allow any PWM switching until the LDO output has reached 90 % of its final value.

On-Chip LDO Bias the SiC403

The following steps must be followed when using the onchip LDO to bias the device.

- Connect V_{DD} to V_{LDO} before enabling the LDO.
- The LDO has an initial current limit of 40 mA at start-up, therefore, do not connect any external load to V_{LDO} during start-up.
- When V_{LDO} reaches 90 % of its final value, the LDO current limit increases to 200 mA. At this time the LDO may be used to supply the required bias current to the device.

Attempting to operate in self-powered mode in any other configuration can cause unpredictable results and may damage the device.

Design Procedure

When designing a switch mode power supply, the input voltage range, load current, switching frequency, and inductor ripple current must be specified.

The maximum input voltage (V_{INMAX}) is the highest specified input voltage. The minimum input voltage (V_{INMIN}) is determined by the lowest input voltage after evaluating the voltage drops due to connectors, fuses, switches, and PCB traces.

The following parameters define the design:

- Nominal output voltage (V_{OUT})
- Static or DC output tolerance
- Transient response
- Maximum load current (I_{OUT})

There are two values of load current to evaluate - continuous load current and peak load current. Continuous load current relates to thermal stresses which drive the selection of the inductor and input capacitors. Peak load current determines instantaneous component stresses and filtering requirements such as inductor saturation, output capacitors, and design of the current limit circuit.

The following values are used in this design:

- $V_{IN} = 12\text{ V} \pm 10\%$
- $V_{OUT} = 1.05\text{ V} \pm 4\%$
- $f_{SW} = 250\text{ kHz}$
- Load = 6 A maximum

Frequency Selection

Selection of the switching frequency requires making a trade-off between the size and cost of the external filter components (inductor and output capacitor) and the power conversion efficiency.

The desired switching frequency is 250 kHz which results from using component selected for optimum size and cost.

A resistor (R_{TON}) is used to program the on-time (indirectly setting the frequency) using the following equation.

$$R_{ton} = \frac{(t_{ON} - 10\text{ ns}) \times V_{IN}}{25\text{ pF} \times V_{OUT}}$$

To select R_{TON} , use the maximum value for V_{IN} , and for t_{ON} use the value associated with maximum V_{IN} .

$$t_{ON} = \frac{V_{OUT}}{V_{INMAX} \times f_{SW}}$$

$t_{ON} = 318\text{ ns}$ at 13.2 V_{IN} , 1.05 V_{OUT} , 250 kHz

Substituting for R_{TON} results in the following solution

$R_{TON} = 154.9\text{ k}\Omega$, use $R_{TON} = 154\text{ k}\Omega$.

Inductor Selection

In order to determine the inductance, the ripple current must first be defined. Low inductor values result in smaller size but create higher ripple current which can reduce efficiency. Higher inductor values will reduce the ripple current and voltage and for a given DC resistance are more efficient. However, larger inductance translates directly into larger packages and higher cost. Cost, size, output ripple, and efficiency are all used in the selection process.

The ripple current will also set the boundary for power-save operation. The switching will typically enter power-save mode when the load current decreases to 1/2 of the ripple current. For example, if ripple current is 4 A then power-save operation will typically start for loads less than 2 A. If ripple current is set at 40 % of maximum load current, then power-save will start for loads less than 20 % of maximum current.

The inductor value is typically selected to provide a ripple current that is between 25 % to 50 % of the maximum load current. This provides an optimal trade-off between cost, efficiency, and transient performance.

During the DH on-time, voltage across the inductor is ($V_{IN} - V_{OUT}$). The equation for determining inductance is shown next.

$$L = \frac{(V_{IN} - V_{OUT}) \times t_{ON}}{I_{RIPPLE}}$$

Example

In this example, the inductor ripple current is set equal to 50 % of the maximum load current. Thus ripple current will be 50 % x 6 A or 3 A. To find the minimum inductance needed, use the V_{IN} and T_{ON} values that correspond to V_{INMAX} .

$$L = \frac{(13.2 - 1.05) \times 318\text{ ns}}{3\text{ A}} = 1.28\text{ }\mu\text{H}$$

A slightly larger value of 1.3 μH is selected. This will decrease the maximum I_{RIPPLE} to 2.9 A.

Note that the inductor must be rated for the maximum DC load current plus 1/2 of the ripple current. The ripple current under minimum V_{IN} conditions is also checked using the following equations.

$$T_{\text{ON_VINMIN}} = \frac{25 \text{ pF} \times R_{\text{TON}} \times V_{\text{OUT}}}{V_{\text{INMIN}}}$$

$$I_{\text{RIPPLE}} = \frac{(V_{\text{IN}} - V_{\text{OUT}}) \times T_{\text{ON}}}{L}$$

$$I_{\text{RIPPLE_VIN}} = \frac{(10.8 - 1.05) \times 384 \text{ ns}}{1.3 \mu\text{H}} = 2.88 \text{ A}$$

Capacitor Selection

The output capacitors are chosen based on required ESR and capacitance. The maximum ESR requirement is controlled by the output ripple requirement and the DC tolerance. The output voltage has a DC value that is equal to the valley of the output ripple plus 1/2 of the peak-to-peak ripple. Change in the output ripple voltage will lead to a change in DC voltage at the output.

The design goal is that the output voltage regulation be $\pm 4\%$ under static conditions. The internal 500 mV reference tolerance is 1%. Allowing 1% tolerance from the FB resistor divider, this allows 2% tolerance due to V_{OUT} ripple.

Since this 2% error comes from 1/2 of the ripple voltage, the allowable ripple is 4%, or 42 mV for a 1.05 V output.

The maximum ripple current of 4.4 A creates a ripple voltage across the ESR. The maximum ESR value allowed is shown by the following equations.

$$ESR_{\text{MAX}} = \frac{V_{\text{RIPPLE}}}{I_{\text{RIPPLEMAX}}} = \frac{42 \text{ mV}}{2.9 \text{ A}}$$

$$ESR_{\text{MAX}} = 9.5 \text{ m}\Omega$$

The output capacitance is usually chosen to meet transient requirements. A worst-case load release, from maximum load to no load at the exact moment when inductor current is at the peak, determines the required capacitance. If the load release is instantaneous (load changes from maximum to zero in $< 1 \mu\text{s}$), the output capacitor must absorb all the inductor's stored energy. This will cause a peak voltage on the capacitor according to the following equation.

$$C_{\text{OUT_MIN}} = \frac{L (I_{\text{OUT}} + \frac{1}{2} \times I_{\text{RIPPLEMAX}})^2}{(V_{\text{PEAK}})^2 - (V_{\text{OUT}})^2}$$

Assuming a peak voltage V_{PEAK} of 1.150 (100 mV rise upon load release), and a 10 A load release, the required capacitance is shown by the next equation.

$$C_{\text{OUT_MIN}} = \frac{1.3 \mu\text{H} (6 + \frac{1}{2} \times 2.9)^2}{(1.15)^2 - (1.05)^2}$$

$$C_{\text{OUT_MIN}} = 328 \mu\text{F}$$

If the load release is relatively slow, the output capacitance can be reduced. At heavy loads during normal switching, when the FB pin is above the 750 mV reference, the DL output is high and the low-side MOSFET is on. During this time, the voltage across the inductor is approximately $-V_{\text{OUT}}$. This causes a down-slope or falling di/dt in the inductor. If the load di/dt is not much faster than the $-di/dt$ in the inductor, then the inductor current will tend to track the falling load current. This will reduce the excess inductive energy that must be absorbed by the output capacitor, therefore a smaller capacitance can be used.

The following can be used to calculate the needed capacitance for a given di_{LOAD}/dt :

Peak inductor current is shown by the next equation.

$$I_{\text{LPK}} = I_{\text{MAX}} + \frac{1}{2} \times I_{\text{RIPPLEMAX}}$$

$$I_{\text{LPK}} = 6 + \frac{1}{2} \times 2.9 = 7.45 \text{ A}$$

Rate of change of load current = di_{LOAD}/dt

I_{MAX} = maximum load release = 6 A

$$C_{\text{OUT}} = I_{\text{LPK}} \times \frac{L \times \frac{I_{\text{LPK}}}{V_{\text{OUT}}} - \frac{I_{\text{MAX}}}{di_{\text{LOAD}}}}{2 (V_{\text{PK}} - V_{\text{OUT}})} \times dt$$

Example

$$\text{Load } \frac{di_{\text{LOAD}}}{dt} = \frac{2.5 \text{ A}}{\mu\text{s}}$$

This would cause the output current to move from 10 A to zero in 4 μs as shown by the following equation.

$$C_{\text{OUT}} = 7.45 \times \frac{1.3 \mu\text{H} \times \frac{7.45}{1.05} - \frac{6}{2.5} \times 1 \mu\text{s}}{2 (1.15 - 1.05)}$$

$$C_{\text{OUT}} = 254 \mu\text{F}$$

Note that C_{OUT} is much smaller in this example, 254 μF compared to 328 μF based on a worst-case load release. To meet the two design criteria of minimum 254 μF and maximum 9 m Ω ESR, select two capacitors rated at 150 μF and 18 m Ω ESR.

It is recommended that an additional small capacitor be placed in parallel with C_{OUT} in order to filter high frequency switching noise.

Stability Considerations

Unstable operation is possible with adaptive on-time controllers, and usually takes the form of double-pulsing or ESR loop instability.

Double-pulsing occurs due to switching noise seen at the FB input or because the FB ripple voltage is too low. This causes the FB comparator to trigger prematurely after the 250 ns minimum off-time has expired. In extreme cases the noise can cause three or more successive on-times. Double-pulsing will result in higher ripple voltage at the output, but in most applications it will not affect operation.

This form of instability can usually be avoided by providing the FB pin with a smooth, clean ripple signal that is at least 10 mV_{p-p}, which may dictate the need to increase the ESR of the output capacitors. It is also imperative to provide a proper PCB layout as discussed in the Layout Guidelines section.

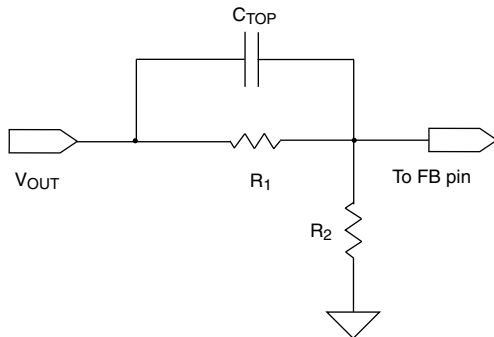

Figure 13 - Capacitor Coupling to FB Pin

Another way to eliminate doubling-pulsing is to add a small (~ 10 pF) capacitor across the upper feedback resistor, as shown in figure 13. This capacitor should be left unpopulated until it can be confirmed that double-pulsing exists. Adding the C_{TOP} capacitor will couple more ripple into FB to help eliminate the problem. An optional connection on the PCB should be available for this capacitor.

ESR loop instability is caused by insufficient ESR. The details of this stability issue are discussed in the ESR Requirements section. The best method for checking stability is to apply a zero-to-full load transient and observe the output voltage ripple envelope for overshoot and ringing. Ringing for more than one cycle after the initial step is an indication that the ESR should be increased.

One simple way to solve this problem is to add trace resistance in the high current output path. A side effect of adding trace resistance is output decreased load regulation.

ESR Requirements

A minimum ESR is required for two reasons. One reason is to generate enough output ripple voltage to provide 10 mV_{p-p} at the FB pin (after the resistor divider) to avoid double-pulsing.

The second reason is to prevent instability due to insufficient ESR. The on-time control regulates the valley of the output ripple voltage. This ripple voltage is the sum of the two voltages. One is the ripple generated by the ESR, the other is the ripple due to capacitive charging and discharging during the switching cycle. For most applications the minimum ESR ripple voltage is dominated by the output capacitors, typically SP or POSCAP devices. For stability the ESR zero of the output capacitor should be lower than approximately one-third the switching frequency. The formula for minimum ESR is shown by the following equation.

$$ESR_{MIN} = \frac{3}{2 \times \pi \times C_{OUT} \times f_{SW}}$$

For applications using ceramic output capacitors, the ESR is normally too small to meet the above ESR criteria. In these applications it is necessary to add a small virtual ESR network composed of two capacitors and one resistor, as shown in figure 14. This network creates a ramp voltage across C_L, analogous to the ramp voltage generated across the ESR of a standard capacitor. This ramp is then capacitive-coupled into the FB pin via capacitor C_C.

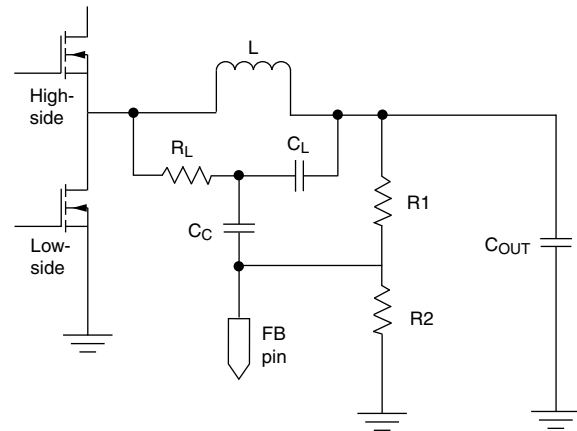

Figure 14 - Virtual ESR Ramp Current

Dropout Performance

The output voltage adjusts range for continuous-conduction operation is limited by the fixed 250 ns (typical) minimum off-time of the one-shot. When working with low input voltages, the duty-factor limit must be calculated using worst-case values for on and off times. The duty-factor limitation is shown by the next equation.

$$DUTY = \frac{T_{ON(MIN)}}{T_{ON(MIN)} \times T_{OFF(MAX)}}$$

The inductor resistance and MOSFET on-state voltage drops must be included when performing worst-case dropout duty-factor calculations.

System DC Accuracy (V_{OUT} Controller)

Three factors affect V_{OUT} accuracy: the trip point of the FB error comparator, the ripple voltage variation with line and load, and the external resistor tolerance. The error comparator off set is trimmed so that under static conditions it trips when the feedback pin is 750 mV, 1 %.

The on-time pulse from the SiC403 in the design example is calculated to give a pseudo-fixed frequency of 250 kHz. Some frequency variation with line and load is expected. This variation changes the output ripple voltage. Because constant on-time converters regulate to the valley of the output ripple, $\frac{1}{2}$ of the output ripple appears as a DC regulation error. For example, if the output ripple is 50 mV with $V_{IN} = 6$ V, then the measured DC output will be 25 mV above the comparator trip point. If the ripple increases to 80 mV with $V_{IN} = 25$ V, then the measured DC output will be 40 mV above the comparator trip. The best way to minimize this effect is to minimize the output ripple.

To compensate for valley regulation, it may be desirable to use passive droop. Take the feedback directly from the output side of the inductor and place a small amount of trace resistance between the inductor and output capacitor.

This trace resistance should be optimized so that at full load the output droops to near the lower regulation limit. Passive droop minimizes the required output capacitance because the voltage excursions due to load steps are reduced as seen at the load.

The use of 1 % feedback resistors contributes up to 1 % error. If tighter DC accuracy is required, 0.1 % resistors should be used.

The output inductor value may change with current. This will change the output ripple and therefore will have a minor effect on the DC output voltage. The output ESR also affects the output ripple and thus has a minor effect on the DC output voltage.

Switching Frequency Variations

The switching frequency will vary depending on line and load conditions. The line variations are a result of fixed propagation delays in the on-time one-shot, as well as unavoidable delays in the external MOSFET switching. As V_{IN} increases, these factors make the actual DH on-time slightly longer than the ideal on-time. The net effect is that frequency tends to fall slightly with increasing input voltage. The switching frequency also varies with load current as a result of the power losses in the MOSFETs and the inductor. For a conventional PWM constant-frequency converter, as load increases the duty cycle also increases slightly to compensate for IR and switching losses in the MOSFETs and inductor.

A constant on-time converter must also compensate for the same losses by increasing the effective duty cycle (more time is spent drawing energy from V_{IN} as losses increase). The on-time is essentially constant for a given V_{OUT}/V_{IN} combination, to offset the losses the off-time will tend to reduce slightly as load increases. The net effect is that switching frequency increases slightly with increasing load.

SIC403 EVALUATION BOARD SCHEMATIC

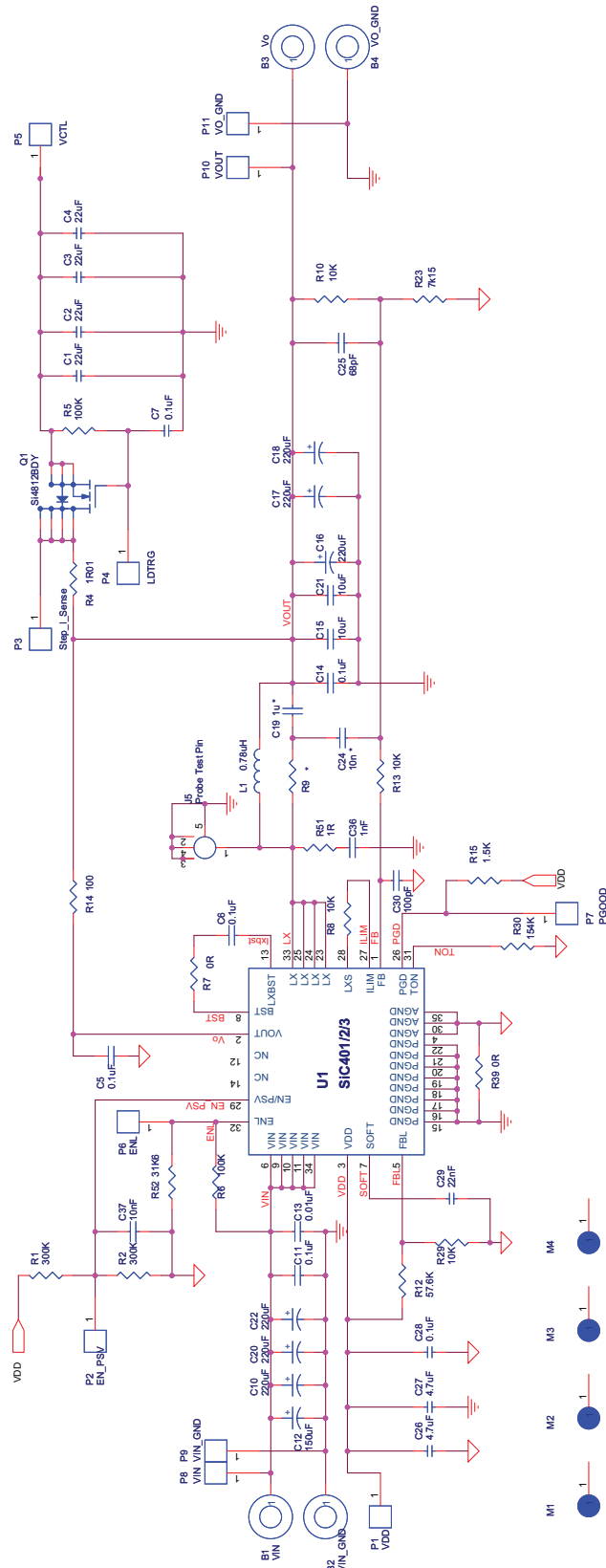

Figure 15. Evaluation Board Schematic



BILL OF MATERIALS							
Item	Qty.	Reference	Value	Voltage	PCB Footprint	Part Number	Manufacturer
1	1	B1	V _{IN}		SOLDER-BANANA	575-4	Keystone
2	1	B2	V _{IN_GND}		SOLDER-BANANA	575-4	Keystone
3	1	B3	V _o		SOLDER-BANANA	575-4	Keystone
4	1	B4	V _{O_GND}		SOLDER-BANANA	575-4	Keystone
5	4	C1, C2, C3, C4	22 µF	16 V	SM/C_1210	GRM32ER71C226ME18L	Murata
6	1	C5	0.1 µF	16 V	SM/C_0402	EMK105BJ104KV-F	Taiyo Yuden
7	1	C6	0.1 µF	50 V	SM/C_0603	VJ0603Y104KXACW1BC	Murata
8	3	C7, C11, C14	0.1 µF	50 V	SM/C_0603	VJ0603Y104KXACW1BC	Vishay
9	3	C10, C20, C22	220 µF	25 V	595D-D	593D227X0010E2TE3	Vishay
10	1	C12	150 µF	35 V	D8X11.5-D0.6X3.5	EEU-FM1V151	Panasonic
11	1	C13	0.01 µF	50 V	SM/C_0402	VJ0402Y103KXACW1BC	Vishay
12	2	C15, C21	10 µF	16 V	SM/C_1206	C3216X7R1C106M	TDK
13	3	C16, C17, C18	220 µF	10 V	595D-D	593D227X0010E2TE3	Vishay
14	1	C19	1 µΩ		SM/C_0603		
15	1	C24	10 nΩ		SM/C_0603		
16	1	C25	68 pF	50 V	SM/C_0402	0402YA680JAT2A	AVX
17	2	C26, C27	4.7 µF	10 V	SM/C_0805	LMK212B7475KG-T	TAIYO YUDEN
18	1	C28	0.1 µF	10 V	SM/C_0603	GRM155R61A105KE19D	Murata
19	1	C29	22 nF	16 V	SM/C_0603		Murata
20	1	C30	100 pF	50 V	SM/C_0402	VJ0402Y101KXACW1BC	Vishay
21	1	C36	1 nF	50 V	SM/C_0402	C0402C102K3RA	Vishay
22	1	C37	10 nF	50 V	SM/C_0402	VJ0402A103KXACW1BC	Vishay
23	1	J5	Probe Test Pin		LECROY PROBE PIN	PK007-015	
24	1	L1	0.78 µH		IHLP4040	IHLP4040DZERR78M11	Vishay
25	4	M1, M2, M3, M4	M HOLE2		STACKING SPACER	8834	Keystone
26	1	P1	V _{DD}		Probe Hook - d76	1573-3	Keystone
27	1	P2	EN_PSV		Probe Hook - d76	1573-3	Keystone
28	1	P3	Step_I_Sense		Probe Hook - d76	1573-3	Keystone
29	1	P4	LDTRG		Probe Hook - d76	1573-3	Keystone
30	1	P5	V _{CTL}		Probe Hook - d76	1573-3	Keystone
31	1	P6	ENL		Probe Hook - d76	1573-3	Keystone
32	1	P7	PGOOD		Probe Hook - d76	1573-3	Keystone
33	1	P8	V _{IN}		Probe Hook - d76	1573-3	Keystone
34	1	P9	V _{IN_GND}		Probe Hook - d76	1573-3	Keystone
35	1	P10	V _{OUT}		Probe Hook - d76	1573-3	Keystone
36	1	P11	V _{O_GND}		Probe Hook - d76	1573-3	Keystone
37	1	Q1	Si4812BDY	30 V	SO-8	Si4812BDY	Vishay
38	1	R1	300K	50 V	SM/C_0603	CRCW060310K0FKEA	Vishay
39	1	R2	300K	50 V	SM/C_0603	CRCW06030000FKEA	Vishay
40	1	R4	1R01	200 V	C_2512	CRCW25121R00FKTA	Vishay
41	2	R5, R6	100K	50 V	SM/C_0603	CRCW0603100KFKEA	Vishay
42	1	R7	0R	50 V	SM/C_0603	CRCW06030000Z0EA	Vishay



BILL OF MATERIALS							
43	3	R8, R10, R29	10K	50 V	SM/C_0603	CRCW060310K0FKEA	Vishay
44	1	R9	Ω		SM/C_0603		
45	1	R12	57.6K	50 V	SM/C_0603	CRCW060357K6FKEA	Vishay
46	1	R13	10K	50 V	SM/C_0402	CRCW040210K0FKED	Vishay
47	1	R14	100	50 V	SM/C_0402	CRCW040210K0FKED	Vishay
48	1	R15	1.5K		SM/C_0603	CRCW06031K50FKEA	Vishay
49	1	R23	7k15		SM/C_0603	CRCW06037K15FKEA	Vishay
50	1	R30	154K		SM/C_0603	CRCW0603154KFKEA	Vishay
51	1	R39	0R		SM/C_0402	CRCW04020000Z0ED	Vishay
52	1	R51	1R		SM/C_0805	CRCW08051R00FNEA	Vishay
53	1	R52	31K6	50 V	SM/C_0603	CRCW060331K6FKEA	Vishay
54	1	U1	SiC401/2/3		MLPQ5x5-32L		Vishay

PCB LAYOUT OF THE EVALUATION BOARD

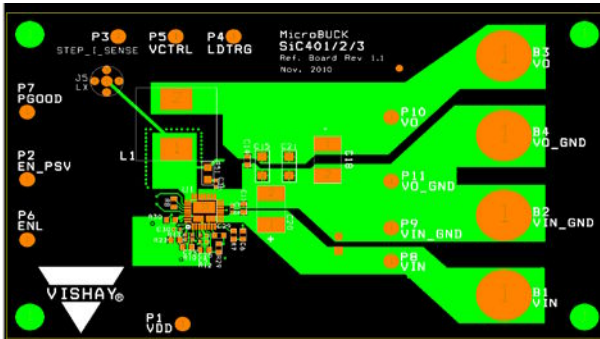

Figure 14. Top Layer

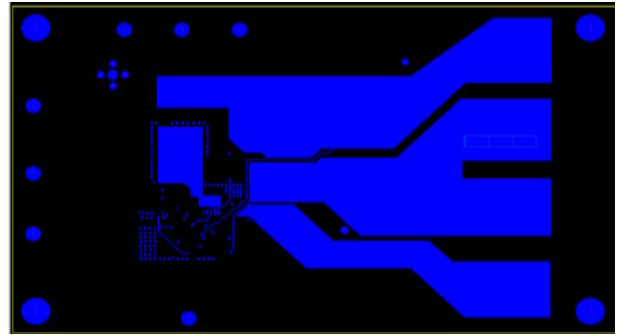

Figure 15. Middle Layer 1

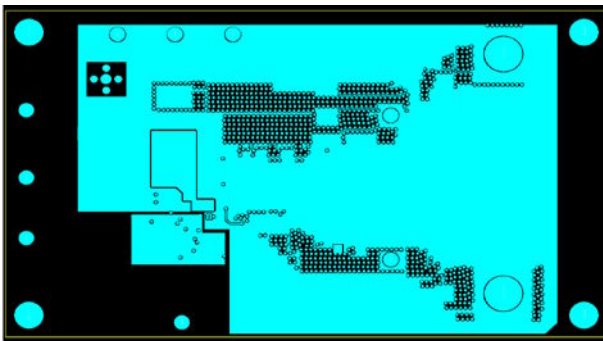

Figure 16. Middle Layer 2

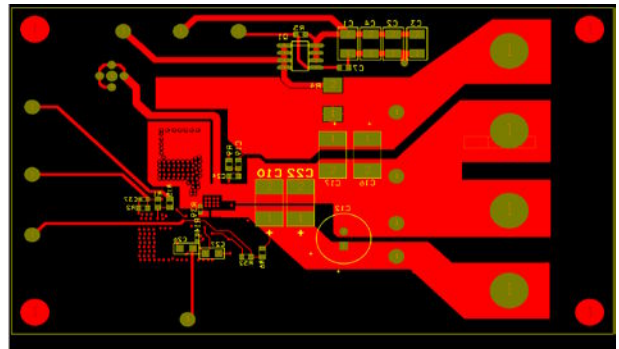

Figure 17. Bottom Layer

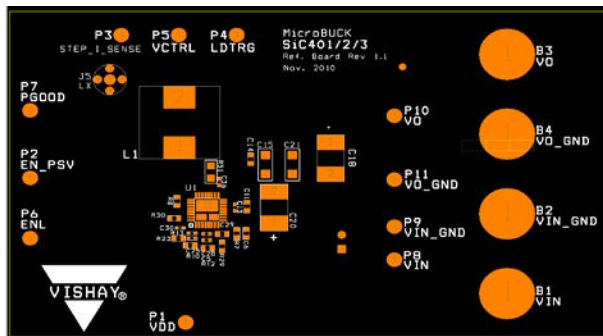

Figure 15. Top Component

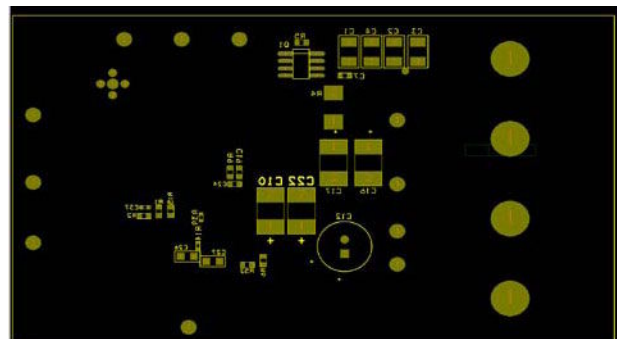
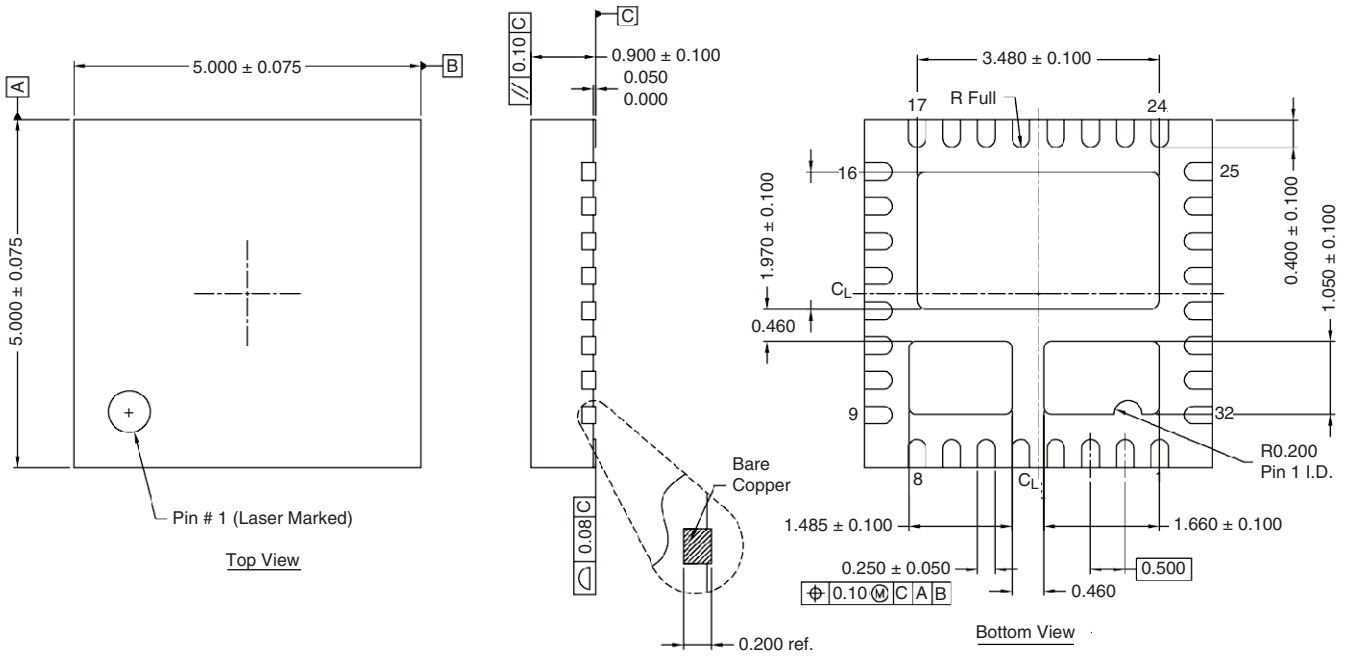

Figure 17. Bottom Component

PACKAGE DIMENSIONS AND MARKING INFO



Vishay Siliconix maintains worldwide manufacturing capability. Products may be manufactured at one of several qualified locations. Reliability data for Silicon Technology and Package Reliability represent a composite of all qualified locations. For related documents such as package/tape drawings, part marking, and reliability data, see www.vishay.com/ppg?66550.

PowerPAK® MLP55-32L CASE OUTLINE

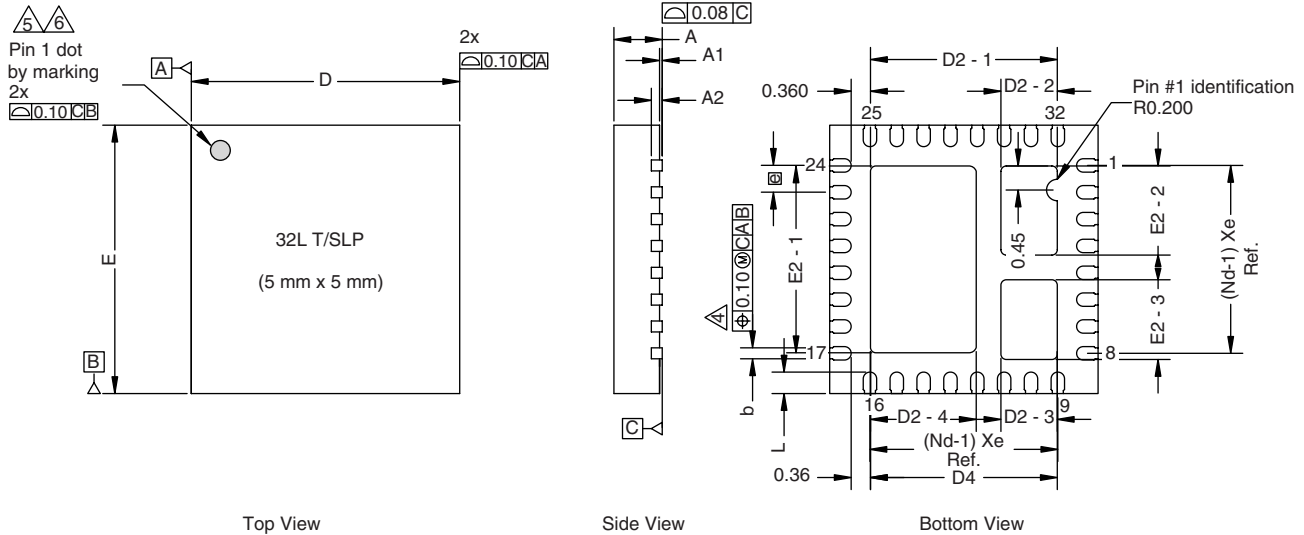

Top View

Side View

Bottom View

DIM	MILLIMETERS			INCHES		
	MIN.	NOM.	MAX.	MIN.	NOM.	MAX.
A	0.80	0.85	0.90	0.031	0.033	0.035
A1 ⁽⁸⁾	0.00	-	0.05	0.000	-	0.002
A2	0.20 REF.			0.008 REF.		
b ⁽⁴⁾	0.20	0.25	0.30	0.078	0.098	0.011
D	5.00 BSC			0.196 BSC		
\square	0.50 BSC			0.019 BSC		
E	5.00 BSC			0.196 BSC		
L	0.35	0.40	0.45	0.013	0.015	0.017
N ⁽³⁾	32			32		
Nd ⁽³⁾	8			8		
Ne ⁽³⁾	8			8		
D2 - 1	3.43	3.48	3.53	0.135	0.137	0.139
D2 - 2	1.00	1.05	1.10	0.039	0.041	0.043
D2 - 3	1.00	1.05	1.10	0.039	0.041	0.043
D2 - 4	1.92	1.97	2.02	0.075	0.077	0.079
E2 - 1	3.43	3.48	3.53	0.135	0.137	0.139
E2 - 2	1.61	1.66	1.71	0.063	0.065	0.067
E2 - 3	1.43	1.48	1.53	0.056	0.058	0.060

ECN: T-08957-Rev. A, 29-Dec-08
DWG: 5983

Notes

- Use millimeters as the primary measurement.
- Dimensioning and tolerances conform to ASME Y14.5M. - 1994.
- N is the number of terminals.
Nd is the number of terminals in X-direction and Ne is the number of terminals in Y-direction.
- Dimension b applies to plated terminal and is measured between 0.20 mm and 0.25 mm from terminal tip.
- The pin #1 identifier must be existed on the top surface of the package by using indentation mark or other feature of package body.
- Exact shape and size of this feature is optional.
- Package warpage max. 0.08 mm.
- Applied only for terminals.



Disclaimer

ALL PRODUCT, PRODUCT SPECIFICATIONS AND DATA ARE SUBJECT TO CHANGE WITHOUT NOTICE TO IMPROVE RELIABILITY, FUNCTION OR DESIGN OR OTHERWISE.

Vishay Intertechnology, Inc., its affiliates, agents, and employees, and all persons acting on its or their behalf (collectively, "Vishay"), disclaim any and all liability for any errors, inaccuracies or incompleteness contained in any datasheet or in any other disclosure relating to any product.

Vishay makes no warranty, representation or guarantee regarding the suitability of the products for any particular purpose or the continuing production of any product. To the maximum extent permitted by applicable law, Vishay disclaims (i) any and all liability arising out of the application or use of any product, (ii) any and all liability, including without limitation special, consequential or incidental damages, and (iii) any and all implied warranties, including warranties of fitness for particular purpose, non-infringement and merchantability.

Statements regarding the suitability of products for certain types of applications are based on Vishay's knowledge of typical requirements that are often placed on Vishay products in generic applications. Such statements are not binding statements about the suitability of products for a particular application. It is the customer's responsibility to validate that a particular product with the properties described in the product specification is suitable for use in a particular application. Parameters provided in datasheets and / or specifications may vary in different applications and performance may vary over time. All operating parameters, including typical parameters, must be validated for each customer application by the customer's technical experts. Product specifications do not expand or otherwise modify Vishay's terms and conditions of purchase, including but not limited to the warranty expressed therein.

Except as expressly indicated in writing, Vishay products are not designed for use in medical, life-saving, or life-sustaining applications or for any other application in which the failure of the Vishay product could result in personal injury or death. Customers using or selling Vishay products not expressly indicated for use in such applications do so at their own risk. Please contact authorized Vishay personnel to obtain written terms and conditions regarding products designed for such applications.

No license, express or implied, by estoppel or otherwise, to any intellectual property rights is granted by this document or by any conduct of Vishay. Product names and markings noted herein may be trademarks of their respective owners.

单击下面可查看定价，库存，交付和生命周期等信息

[>>Vishay\(威世\)](#)