

APPROVAL SHEET

WW25N_J

±1%, ±5%, 2W

Ultra low ohm power chip resistors

Size 2512 (6432)

Metal Current Sensing Type

Automotive AEC Q200 compliant

Anti-Sulfuration ASTM B-809 105°C 1000hrs

RoHS Exemption free and Lead free products

Halogen free

*Contents in this sheet are subject to change without prior notice.

FEATURE

1. Ultra low and stable TCR performance
2. High power rating and compact size
3. RoHS Exemption free and Lead free products.
4. Inductance below 1nH
5. Automotive grade AEC Q200 compliant
6. ASTM B-809 105°C 1000hrs compliant / Oil 3.5% sulphur 105°C 500hrs compliant

APPLICATION

- Power supply
- PDA
- Digital meter
- Computer
- Automotives
- Battery charger
- DC-DC power converter

DESCRIPTION

The resistors are constructed in a high grade low resistive metal body. The resistive layer is covered with a protective coat and printed a resistance marking code over it. Finally, the two external end terminations are added. For ease of soldering the outer layer of these end terminations is a tin (lead-free) alloy.

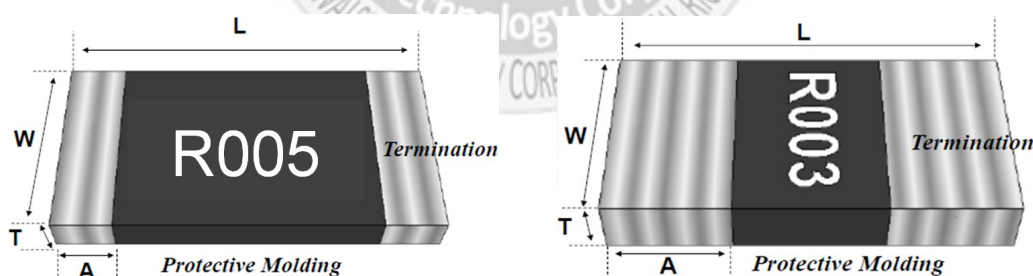

Item	Protective Molding	Resistive Element	Internal Terminal	External Terminal
Material	Resin	Alloy Metal	Copper	Solder

Fig 1. Construction of Chip-R

QUICK REFERENCE DATA

Item	General Specification	
Series No.	WW25N	
Size code	2512 (6432)	
Resistance Tolerance	±5%, ±1%	
Resistance Value	0.001Ω, 0.002Ω	0.003Ω, 0.004Ω, 0.005Ω, 0.006Ω, 0.007Ω, 0.008Ω, 0.009Ω, 0.010Ω, 0.012Ω, 0.015Ω, 0.018Ω, 0.020Ω, 0.022Ω, 0.025Ω, 0.030Ω, 0.033Ω, 0.035Ω, 0.040Ω, 0.050Ω, 0.060Ω, 0.070Ω, 0.075Ω, 0.080Ω, 0.100Ω
TCR (ppm/°C)	≤ ±70 ppm/°C	≤ ±50 ppm/°C
Max. dissipation at T _{amb} =70°C	2 W	
Max. Operation current (DC or RMS)	SQRT (Power / Resistance)	
Operation temperature	-55 ~ +170°C	

Note :

- Resistance value will be changed by soldering condition and design of soldering pad, please design products in consideration of this change of resistance value.

MECHANICAL DATA

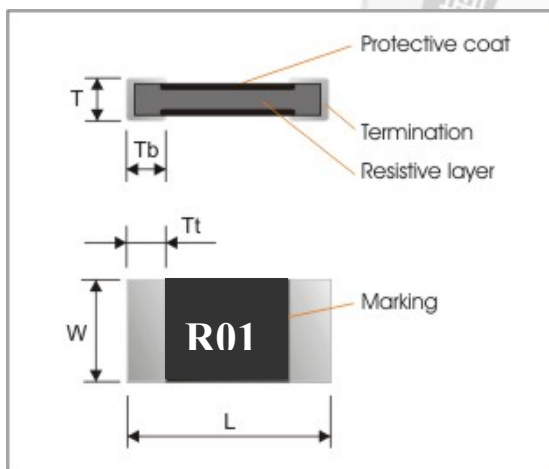

Symbol	R001, R002	R003 ~ R100
L	6.40±0.20	6.20±0.20
W	3.25±0.20	3.25±0.20
T	0.75±0.20	0.60±0.20
Tt	2.00±0.20	0.80±0.20
Tb	2.00±0.20	0.80±0.20

FOOT PRINT

Unit: mm	W	D	L
WW25N 3m ~	3.70	1.60	7.60
WW25N 1m ~ 2m	4.00	3.00	7.30

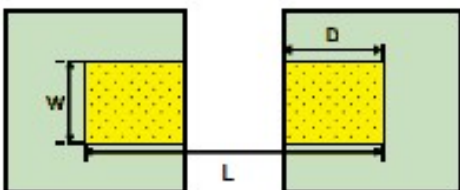

MARKING

Each resistor is marked with a four-digit code on the protective coating to designate the nominal resistance value.

R005 = 5 mΩ

R020 = 20mΩ



R020 = 20mΩ

FUNCTIONAL DESCRIPTION

Derating curve

The power that the resistor can dissipate depends on the operating temperature; see Fig.2

Operating Temperature Range: -55 to +170 deg.C

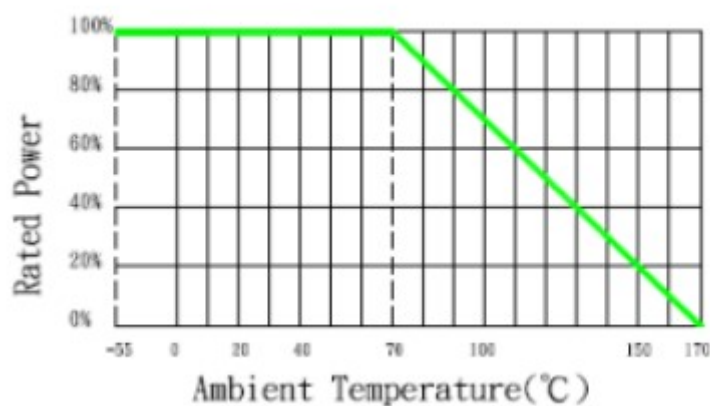

MOUNTING

Due to their rectangular shapes and small tolerances, Surface Mountable Resistors are suitable for handling by automatic placement systems.

Chip placement can be on ceramic substrates and printed-circuit boards (PCBs).

Electrical connection to the circuit is by individual soldering condition.

The end terminations guarantee a reliable contact.

SOLDERING CONDITION

The robust construction of chip resistors allows them to be completely immersed in a solder bath of 260°C for 10 seconds. Therefore, it is possible to mount Surface Mount Resistors on one side of a PCB and other discrete components on the reverse (mixed PCBs).

Surface Mount Resistors are tested for solderability at 235°C during 2 seconds. The test condition for no leaching is 260°C for 30 seconds. Typical examples of soldering processes that provide reliable joints without any damage are given in Fig 3.

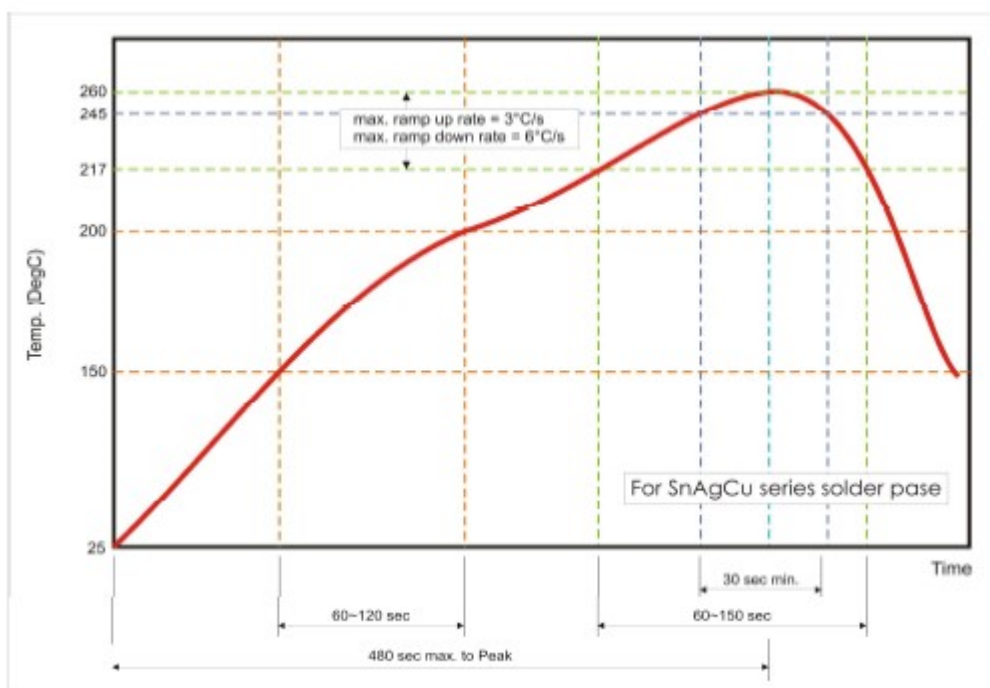

Fig 3. Infrared soldering profile for Chip Resistors WW25

CATALOGUE NUMBERS

The resistors have a catalogue number starting with .

WW25	N	R005	J	T	L	J
Size code WW25 : 2512	Type code N : 2W Sensing type	Resistance code R is first digit followed by 3 significant digits. 0.010Ω = R010 0.005Ω = R005	Tolerance J : ±5% F : ±1%	Packaging code T : 7" reeled in tape Q : 10" reel in tape	Termination code L = Sn base (lead free)	Special code J = Automotive AEC Q200 compliant

Reeled tape packaging : 12mm width plastic emboss taping 4,000pcs per reel. 8,000pcs per 10" reel.

TEST AND REQUIREMENTS(JIS C 5201-1 : 1998)

Essentially all tests are carried out according to the schedule of IEC publication 115-8, category **LCT/UCT/56**(rated temperature range : Lower Category Temperature, Upper Category Temperature; damp heat, long term, 56 days). The testing also meets the requirements specified by EIA, EIAJ and JIS.

The tests are carried out in accordance with IEC publication 68, "Recommended basic climatic and mechanical robustness testing procedure for electronic components" and under standard atmospheric conditions according to IEC 60068-1, subclause 5.3. Unless otherwise specified, the following value supplied :

Temperature: 15°C to 35°C.

Relative humidity: 45% to 75%.

Air pressure: 86kPa to 106 kPa (860 mbar to 1060 mbar).

All soldering tests are performed with mildly activated flux.

TEST	PROCEDURE	REQUIREMENT
High Temperature Exposure(Storage) : MIL-STD-202 Method 108	Test 1000 hrs./ @T=170°C/ Un-powered. Measurement at 24±2 hours after test conclusion	no visible damage ΔR/R max. ±(1%+0.5mΩ)
Temperature cycling JESD22 method JA104	30 minutes at -55°C±3°C, 2~3 minutes at 20°C+5°C-1°C, 30 minutes at +125°C±3°C, 2~3 minutes at 20°C+5°C-1°C, total 5 continuous cycles	no visible damage ΔR/R max. ±(0.5%+0.5mΩ)
Moisture resistance MIL-STD-202 Method 106	Test 65°C, 80-100% RH 10cycles, (t=24hrs/cycle), measurement at 24hrs after test finish.	no visible damage ΔR/R max. ±(0.5%+0.5mΩ)
Bias Humidity MIL-STD-202 Method 103	Test at 85°C/85%RH, 10% of operation power, measurement at 24hrs after test finish.	no visible damage ΔR/R max. ±(1%+0.5mΩ)
Load life (endurance) MIL-STD-202 Method 108	Test 1000hrs, at 125°C, 35% of operation power, measurement at 24hrs after test finish.	no visible damage ΔR/R max. ±(1%+0.5mΩ)
External Visual MIL-STD-883 Method 2009	Visual inspeyion	No visual damage
Physical dimensions JESD22 Method JB-100	The dimensions specified in spec should be checked by Protech 2.5D	Within spec tolerance
Mechanic shock MIL-STD-202 Method 213	Test Peak value:100g's / Wave:Hail-sine / Duration:6ms / Velocity:12.3ft/sec	Within product specification tolerance and no visible damage
Vibration MIL-STD-202 Method 204	Test 5g's for 20min., 12 cycles each of 3 orientations..	no visible damage ΔR/R max. ±(1%+0.5mΩ)
Resistance to soldering heat (R.S.H) MIL-STD-202 Method 210	Un-mounted chips completely immersed for 10±1second in a SAC solder bath at 270°C±5°C	no visible damage ΔR/R max. ±(1%+0.5mΩ)

Thermal shock MIL-STD-202 Method 107	Test -55 to 155°C/ dwell time 15min/ Max transfer time 20sec/ 300cycles	no visible damage $\Delta R/R$ max. $\pm(0.5\%+0.5m\Omega)$
ESD AEC Q-200-002	Test contact 8KV	no visible damage $\Delta R/R$ max. $\pm(1\%+0.5m\Omega)$
Solderability J-STD-002	a) Bake the sample for 155°C dwell time 4hrs/ solder dipping 235°C/ 5sec. b) Steam the sample dwell time 8 hour/ solder dipping 215°C/ 5sec. c) Steam the sample dwell time 8 hour/ solder dipping 260°C/ 7sec.	good tinning (>95% covered) no visible damage
Electrical Characterization	Digital Resistor checker. (T.C.R. 155 \pm 3°C/ 25+5°C-1°C/ -55 \pm 3°C).	Within the specified tolerance TCR $\leq \pm 70$ ppm/°C (3, 4m $\Omega \leq \pm 100$ ppm/°C)
Board flex AEC Q-200-005	Bending min. 2mm	no visible damage $\Delta R/R$ max. $\pm(0.5\%+0.5m\Omega)$
Terminal strength AEC Q-200-006	Pressurizing force: 1.8Kg, Test time: 60 \pm 1sec.	No remarkable damage or removal of the terminations
Sulfuration test ASTM B-809-95	1. ASTM B-809-95 105°C 1000hrs 2. Oil 3.5% sulfur 105°C 500hrs	$\Delta R/R$ max. $\pm(2\%+0.5m\Omega)$ no visible damage. $\Delta R/R$ max. $\pm(1\%+0.5m\Omega)$ no visible damage.
Short time overload (S.T.O.L) Clause 4.13	5 \times Rated power for 5 seconds.	no visible damage $\Delta R/R$ max. $\pm 1\%$

PACKAGING

Plastic Tape specifications (unit :mm)

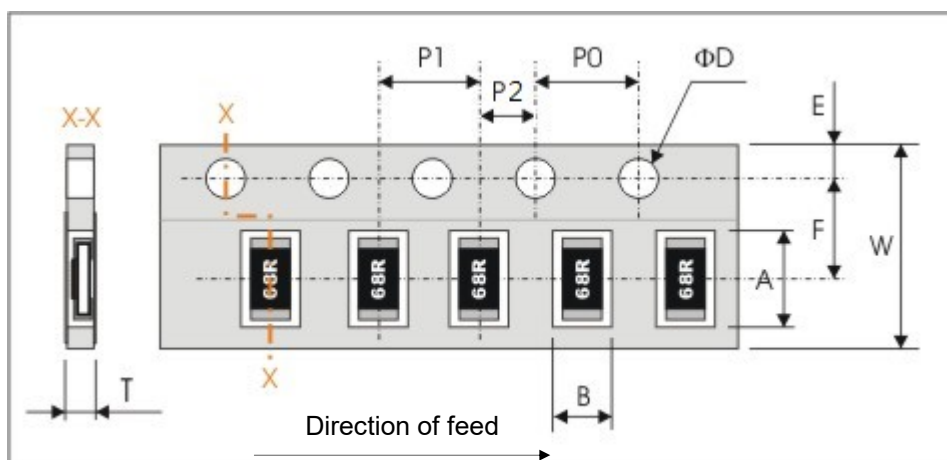

Symbol	A	B	W	F	E
Dimensions	6.75±0.20	3.50±0.20	12.00±0.30	5.50±0.10	1.75±0.10

Symbol	P1	P0	P2	ΦD	T
Dimensions	4.00±0.10	4.00±0.10	2.00±0.10	Φ1.50 ^{+0.1} _{-0.0}	1.00±0.20

Reel dimensions

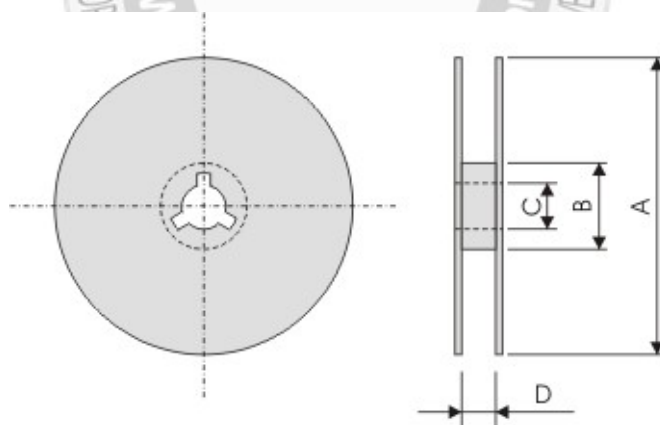

Symbol	A	B	C	D
(unit : mm)	Φ178.0±2.0	Φ60.0±1.0	13.0±0.2	14.0±0.2

Taping quantity

- Chip resistors 4,000 pcs per reel.

单击下面可查看定价，库存，交付和生命周期等信息

[>>Walsin Technology\(华新科技\)](#)