

APPROVAL SHEET

RF Switch Series – RoHS Compliance

SP6T MIPI Switch

Halogens Free Product

Any 2G/3G/4G Antenna Diversity For Receive System

P/N: RFASWH526BTF03

*Contents in this sheet are subject to change without prior notice.

Approval Sheet

FEATURES

- Low Insertion Loss and Low Distortion
- Broadband frequency range : 0.4 to 2.7 GHz
- High Isolation and linearity
- Integrated MIPI RFFE Slave Controller
- High ESD tolerance of 2kV HBM at all pins
- Small QFN (14-pin, 2.0 x 2.0 x 0.55 mm³) package
- **M**oisture **S**ensitive **L**evel 3 (MSL3)

Description

- The RFASWH526BTF03 is a Single Pole, Six Throw (SP6T) antenna switch with an integrated Mobile Industry Processor Interface (MIPI) controller. Using an advanced switching technology, the RFASWH526BTF03 maintains low insertion and high isolation, which makes it an ideal choice for UMTS, CDMA2000, EDGE, GSM, and LTE applications.
- The design integrated six low loss TRX ports. The switch also has an excellent 2nd/3rd Order Intermodulation Distortion (IMD2/IMD3) performance.
- Switching is controlled by the MIPI decoder and High ESD tolerance of 2kV HBM at all pins.
- No blocking capacitor requirements on the RF paths as long as no DC voltage is applied. The RFASWH526BTF03 is manufactured in a compact, 2.0 x 2.0 x 0.55 mm³ package.
- The functional block diagram is shown in Figure 1. The pin assignment and package are shown in Figure 2. Signal pin assignments and functional pin descriptions are provided in Table 1.

Application

- 2G/3G/4G multimode cellular handsets (LTE, UMTS, CDMA2000, EDGE, GSM, TDD-LTE, TD-SCDMA)

Block Diagram and Pin Out (Top View)

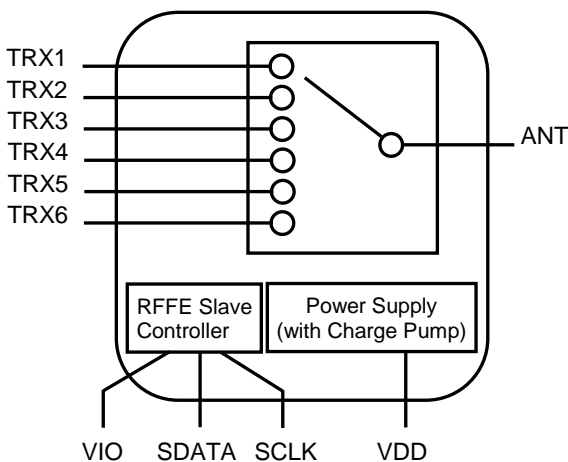

Figure 1. RFASWH526BTF03 Block Diagram

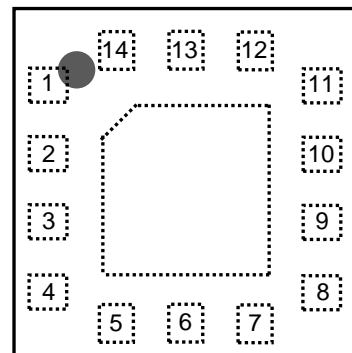

Figure 2. RFASWH526BTF03 Pin assignment

Approval Sheet

Table 1. RFASWH526BTF03 Pin Descriptions

Pin #	Name	Description	Pin #	Name	Description
1	TRx5	RF path 5	8	N/C	Not connected
2	TRx3	RF path 3	9	TRx2	RF path 2
3	TRx1	RF path 1	10	TRx4	RF path 4
4	VDD	DC power supply	11	TRx6	RF path 6
5	VIO	RFFE Interface Power Supply	12	N/C	Not connected
6	SDATA	RFFE Data input/output	13	ANT	Antenna port
7	SCLK	RFFE Clock Input	14	N/C	Not connected

Note 1 : Bottom ground paddles must be connected to ground.

Application Circuit

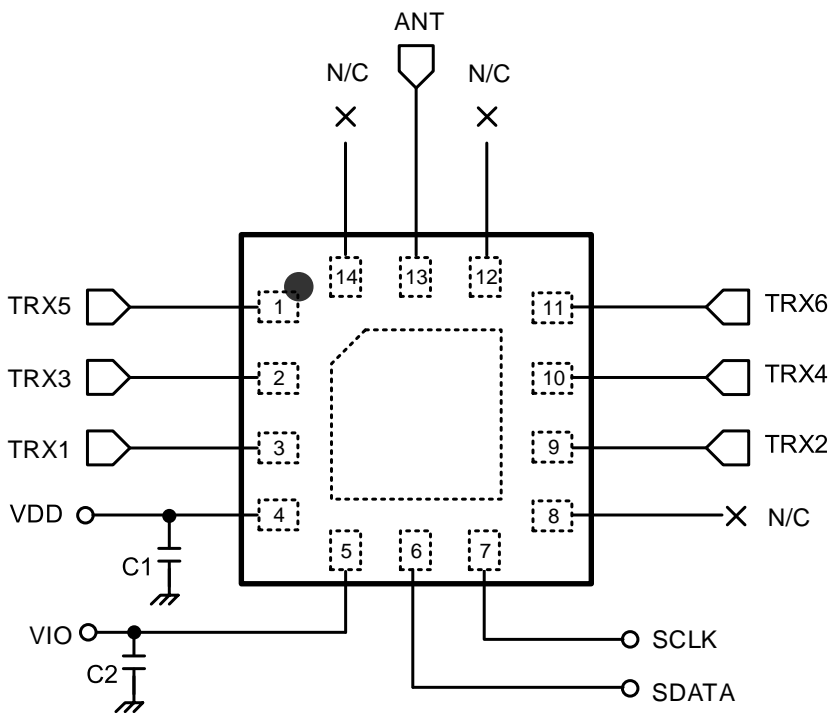

Figure 3. RFASWH526BTF03 Application Circuit

Parts List

Parts No.	Value
C1-C2	0.1 μ F

Table 2. RFASWH526BTF03 Absolute Maximum Ratings

Parameter	Symbol	Minimum	Maximum	Units
RFx Input power	P _{IN}		+26	dBm
Supply Voltage	VDD		3.5	V
Interface Supply Voltage	VIO		2.0	V
Control Input/ Output Voltage Range (SDATA, SCLK)	V _{IN_OUT}		2.0	V
Storage temperature	T _{STG}	-45	+125	°C
Operating temperature	T _{OP}	-30	+90	°C
HBM ESD Voltage, All Pins	V _{ESD} ¹		2000	V
MM ESD Voltage, All Pins	V _{ESD} ²		190	V

Note 1 : Human Body Model ESD Voltage (HBM, MIL_STD 883 Method 3015.7)

Note 2 : Machine Model ESD Voltage (MM, JEITA EIAJ ED-4701)

Exceeding absolute maximum ratings may cause permanent damage. Operation between operating range maximum and absolute maximum for extended periods may reduce reliability.

Electrical and Mechanical Specifications

- The absolute maximum ratings of the RFASWH526BTF03 are provided in Table 2. Electrical specifications are provided in Tables 3 and 5.
- Figure 4, 5 and Table4 describes the RFASWH526BTF03 has four operating states.
- IMD2 and IMD3 test conditions for various frequencies are listed in Tables 6 and 7, respectively.
- Figure 6, 7, 8, 9 and Table8 show the important parameters for SCLK and SDATA required for proper operations of the Toshiba MIPI RFFE slave interface.
- Table 9 register mapping shows the list of the registers inside the RFASWH526BTF03.
- Table 10 provides the switch control register.
- Table 11, 12 and 13 describes the detail information of RFFE status, power mode and trigger states, respectively.
- Figure 10 and Table 14 describes the solder land pad and dimensions..

Table 3. RFASWH526BTF03 DC Electrical Specifications (Note 1)

Parameter	Symbol	Min.	Typ.	Max.	Unit
Supply voltage	VDD	2.5	2.8	3.5	V
Interface supply voltage	VIO	1.65	1.80	1.95	V
Interface signal: High	SDATA	0.8 × VIO		VIO	V
Low		0		0.2 × VIO	V

Note 1 : Performance is guaranteed only under the conditions listed in this Table.

Operating States

The RFASWH526BTF03 has four operating states, which are ACTIVE, SHUTDOWN, STARTUP and LOW POWER. The transitions between these four states are set writing the PWR_MODE register or VIO as shown in Figure 4. The internal circuit operations in each operating state are shown in Table 4.

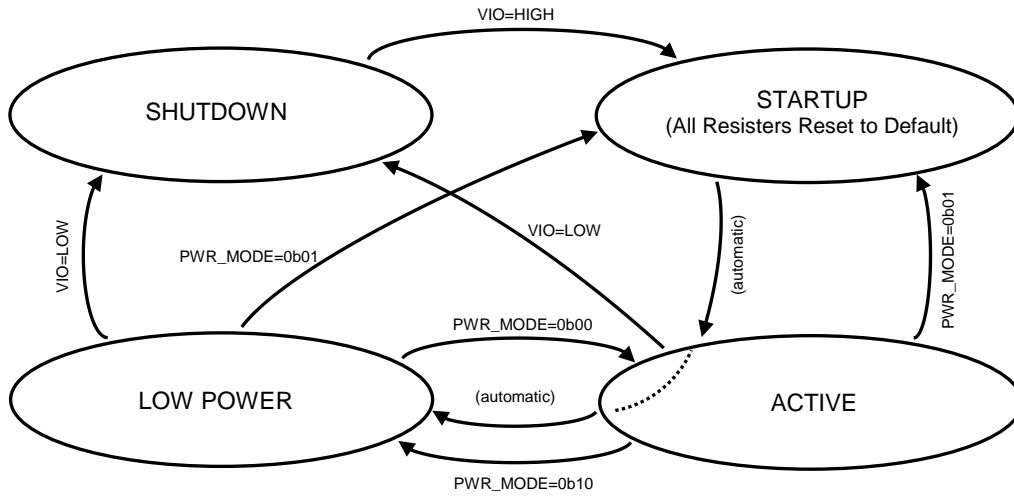

Figure 4. Slave State Diagram

Table 4. RFASWH526BTF03 Internal Operations (Note 1)

Operating State	RFFE Slave Controller	RF Switch Core	Charge Pump
SHUTSOWN	Inactive	Undetermined (Note1)	Off
STARTUP	All registers are set to Default value	Undetermined (Note1)	Off
ACTIVE	Active	Controllable by mipi-command	On
LOW POWER	Active	Undetermined (Note1)	Off

Note 1 : All switch are insufficiently On or Off as the Charge pump is not powered up.

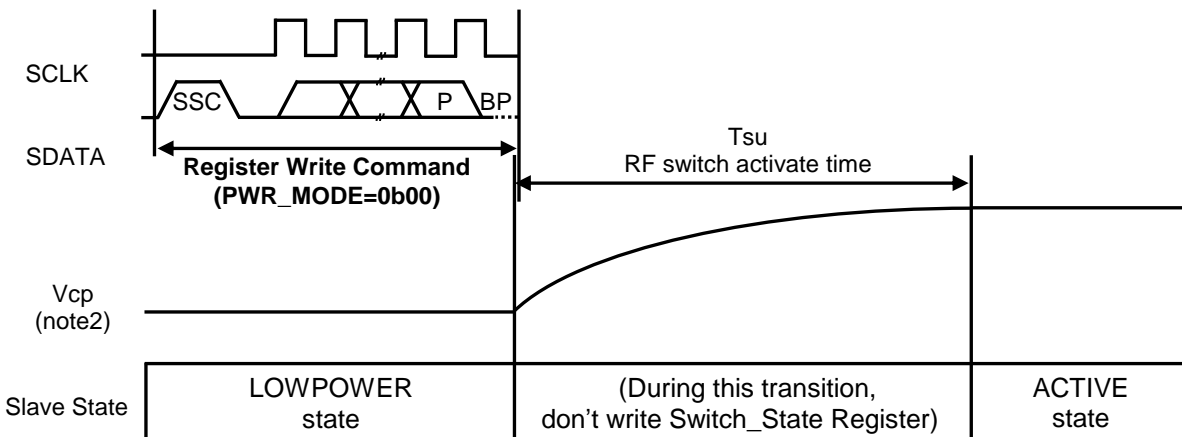

Figure 5. LOW POWER to AVTIVE Process

Note 2 : Vcp is the output voltage of internal charge-pump circuit. The Vcp traces in above figure are only image for illustrative purpose.

Approval Sheet
Table 5. RFASWH526BTF03 RF Electrical Specifications (Note 1)
(T_{op}= 25°C, VDD = 2.8 V, VIO=1.8V, Characteristic Impedance Z₀= 50 Ω, Unless Otherwise Noted)

Parameter	Symbol	Test Condition	Min	Typ.	Max	Units
Operating frequency	f		0.4		2.7	GHz
Insertion loss	IL	TRXx ports: 400 to 960 MHz 1710 to 1980 MHz 1980 to 2690 MHz	-	0.40 0.50 0.76	0.50 0.65 0.90	dB dB dB
Isolation (TRXx to any off TRXx port [non-adjacent ports])	Iso	Up to 1.0 GHz Up to 2.0 GHz Up to 2.7 GHz	30 25 20	42 29 25	-	dB dB dB
Isolation (TRXx to any off TRXx port [adjacent ports])	Iso	Up to 1.0 GHz Up to 2.0 GHz Up to 2.7 GHz	26 20 17	32 25 20	-	dB dB dB
On state match	VSWR	Up to 2.7 GHz		1.43	2.0	-
TRXx harmonics	2fo, 3fo	PIN = +26 dBm, 5:1 VSWR, f = 824 to 2700 MHz		-100	-90	dBc
2 nd Order Intermodulation Distortion	IMD2	See test conditions in Table 6		-104	-100	dBm
3 rd Order Intermodulation Distortion	IMD3	See test conditions in Table 7		-118	-112	dBm
Turn-on time	t _{ON}	From application of VDD and VIO			20	μs
Switching speed	t _s	Port to port			5	μs

Note 1 : Performance is guaranteed only under the conditions listed in this Table.

Table 6. IMD2 Test Conditions

Band	Transmit Frequency (MHz)	Transmit Power (dBm)	Frequency Blocker, Low (MHz)	Frequency Blocker, High (MHz)	Power Blocker (dBm)	Receive Frequency (MHz)
1	1950.0	+20	190	4090	-15	2140.0
2	1880.0		80	3840		1960.0
4	1732.5		400	3865		2132.5
5	836.5		45	1718		881.5
7	2535.0		120	5190		2655.0
8	897.5		45	1840		942.5

Table 7. IMD3 Test Conditions

Band	Transmit Frequency (MHz)	Transmit Power (dBm)	Frequency Blocker (MHz)	Power Blocker (dBm)	Receive Frequency (MHz)
1	1950.0	+20	1760.0	-15	2140.0
2	1880.0		1800.0		1960.0
4	1732.5		1332.5		2132.5
5	836.5		791.5		881.5
7	2535.0		2415.0		2655.0
8	897.5		852.5		942.5

Approval Sheet

Table 8. Digital Interface Timing Specifications
(T_{op} = 25°C, VDD = 2.8 V, VIO = 1.8V, Characteristic Impedance Z_0 = 50 Ω, Unless Otherwise Noted)

Parameter	Symbol	Condition	Min.	Max.	Unit
Data Setup Time (Note 1)	T_S	See the Figure 6, input Tr/Tf = 3.5 to 6.5ns	1	-	ns
Data Hold Time (Note 1)	T_H	See the Figure 6, input Tr/Tf = 3.5 to 6.5ns	5	-	ns
Time for Data Output Valid from SCLK rising edge (Note 2)	T_D	Half Speed Read See the Figure 6 and 7, input Tr/Tf = 3.5 to 10ns	0	22	ns
SDATA Output Transition (Rise/Fall) Time	$T_{SDATAOTR}$	Half Speed Read See the Figure 6 and 7, input Tr/Tf = 3.5 to 10ns	2.1	10	ns
Data Drive Release Time	T_{SDATAZ}	Half Speed Read See the Figure 6 and 7, input Tr/Tf = 3.5 to 10ns	-	18	ns
Vio Supply Rise Time	T_{VIO-R}	See the Figure 8	-	400	μs
RFFE I/O Voltage Reset Timing	$T_{VIO-RST}$	See the Figure 8	10	-	μs
Signal Reset Delay Time	T_{SIGOL}	See the Figure 8	120	-	μs
RF Switching Time	T_{SW}	See the Figure 9	-	5	μs
Switching Interval (Note 3)	T_{int}	See the Figure 9	20	-	μs
Startup Time (Note 4)	T_{SU}	See the Figure 4	-	20	μs

Note 1 : Input SDATA is sampled at the falling edge of the SCLK.

Note 2 : Output SDATA changes at the rising edge of the SCLK.

Note 3 : The time between the consecutive Register Write Command Sequences for the Switch State register.

Note 4 : The time for the switch to reach Active State.

Note : The table of input SCLK signal conditions as below.

Parameter	Symbol	Ratings		Unit
SCLK Frequency	F_{SCLK}	Full Speed	0.032 to 26	MHz
		Half Speed	0.032 to 13	
SCLK Period	T_{SCLK}	Full Speed	0.038 to 32	μs
		Half Speed	0.077 to 32	
SCLK Rise/Fall Time	$T_{SCLKITR}$	Full/Half Speed	3.5 to 6.5	ns
SCLK Input Duty Cycle, High/Low Time	$T_{SCLKDCH}$ $T_{SCLKDCL}$	50		%

Approval Sheet

AC Waveforms

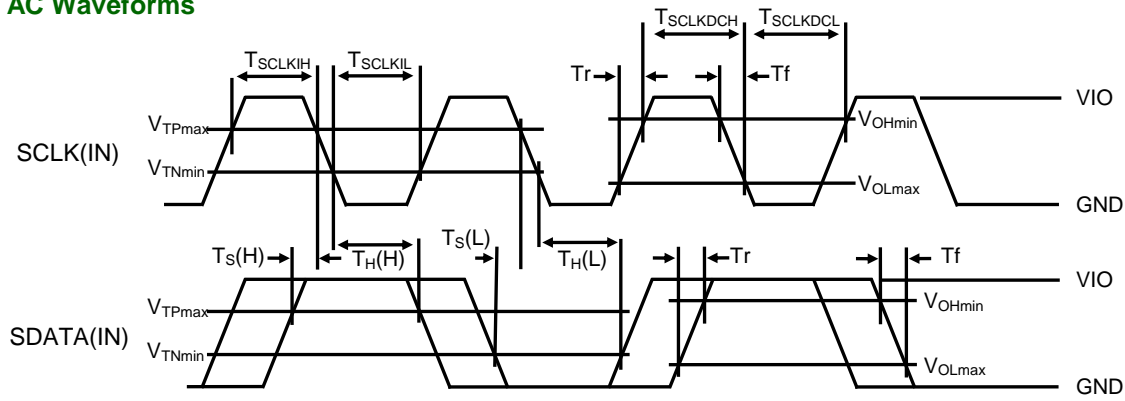

Figure 6. T_{SCLKDH} , $T_{SCLKDCL}$, T_{SCLKIH} , T_{SCLKIL} , T_s , T_H

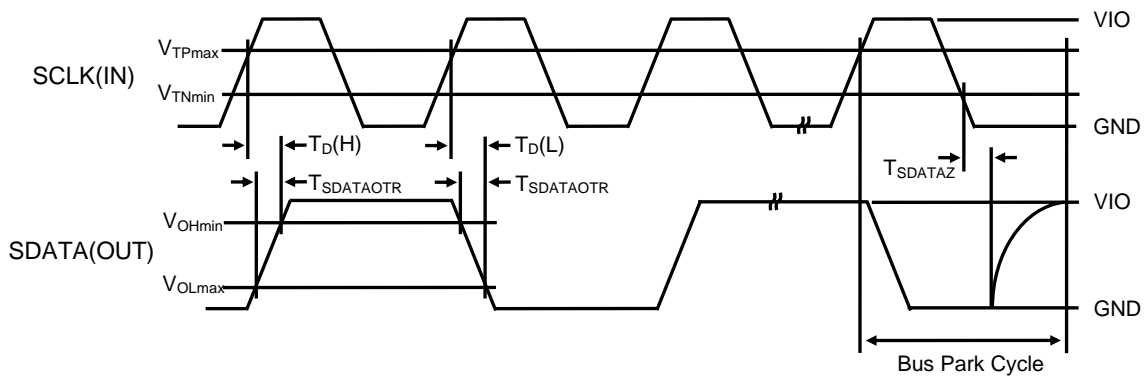

Figure 7. T_D , $T_{SDATAOTR}$, T_{SDATAZ}

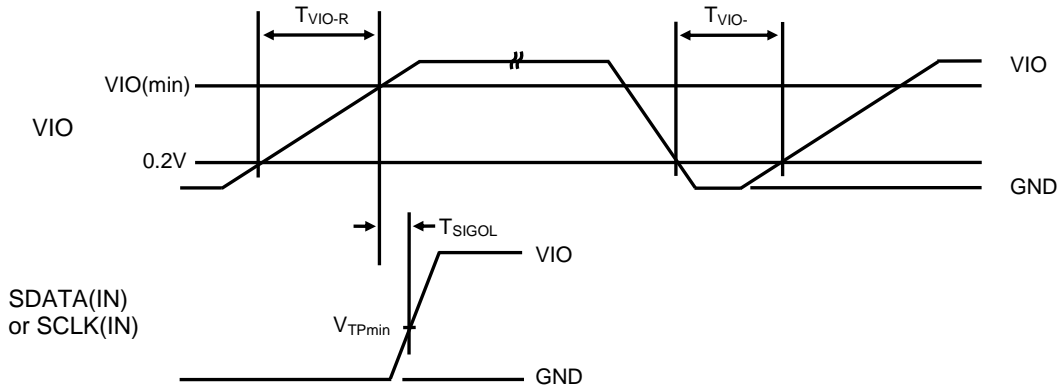

Figure 8. T_{VIO-R} , T_{VIO-} , T_{SIGOL}

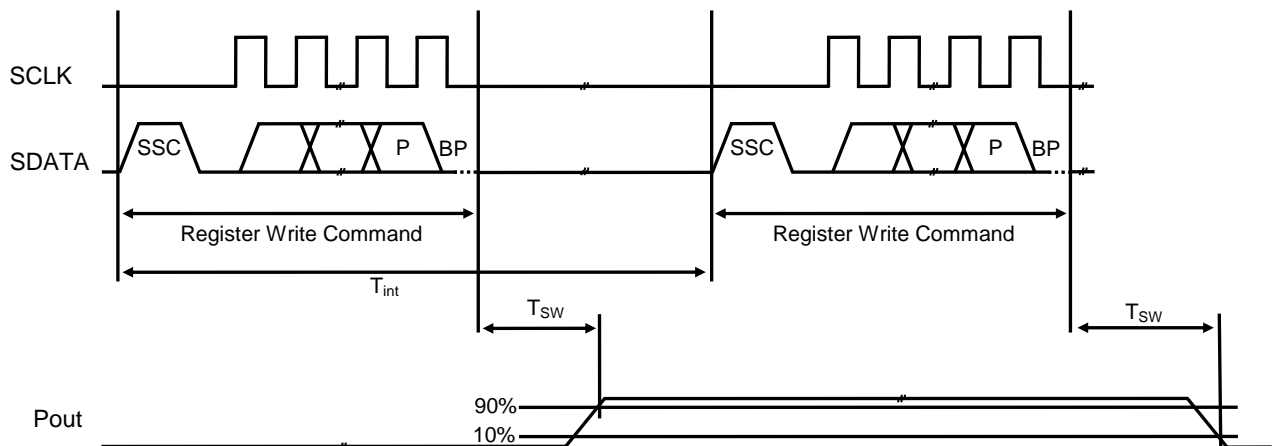

Figure 9. RF Switch Timing

Approval Sheet

Table 9. Register Mapping

Table 9. shows the list of the registers inside the RFASWH526BTF03.

Register Address		Bits	Read/Write	Description	Default Value (binary)
Hex	Binary				
0x00	00000	[7:0]	R/W	Switch Control Register	See Table 10
0x1A	11010	[7:0]	R/W	RFFE Status (see Table 11)	0000 0000
0x1B	11011	[3:0]	R/W	GSID	0000 0000
0x1C	11100	[7:6] [5:0]	R/W	Power Mode (see Table 12) Triggers (see Table 13)	00 000000
0x1D	11101	[7:0]	R	Product ID	0100 1001
0x1E	11110	[7:0]	R	Manufacturer ID [7:0]	0010 0110
0x1F	11111	[7:6] [5:4] [3:0]	R	SPARE	00
				Manufacturer ID [9:8]	01
				USID	1011

Note : The RFASWH526BTF03 start-up procedure as below description.

The RFASWH526BTF03 requires to be disabled the triggers before programming the switch control registers when RFASWH526BTF03 operating in the active mode. The table of register address setup as below.

Register Address		Bits	Read/Write	Value (binary)
Hex	Binary			
0x1C	11100	[7:6] [5:0]	R/W	00 111000

Table 10. Switch Control Register

Antenna Path	Register_0 Bits							
	Bit[7]	Bit[6]	Bit[5]	Bit[4]	Bit[3]	Bit[2]	Bit[1]	Bit[0]
TRX1	0	0	0	0	0	1	1	0
TRX2	0	0	0	0	0	1	0	1
TRX3	0	0	0	0	0	1	1	1
TRX4	0	0	0	0	0	0	1	1
TRX5	0	0	0	0	1	0	0	1
TRX6	0	0	0	0	0	0	0	1
Sleep	0	0	0	0	0	0	0	0
Isolation mode	0	1	1	1	1	1	1	1

Table 11. RFFE Status

D[7:0]	Read/Write	Description
D[7]	R/W	SOFTWARE RESET
D[6]	R	COMMAND_FRAME_PARITY_ERR
D[5]		COMMAND_LENGTH_ERR
D[4]		ADDRESS_FRAME_PARITY_ERR
D[3]		DATA_FRAME_PARITY_ERR
D[2]		READ_UNUSED_REG
D[1]		WRITE_UNUSED_REG
D[0]		BID_GID_ERR

Table 12. Power Mode

D[7:6]	Read/Write	Status
00b	W	Part enters Active mode
	R	Part is in Active mode
01b	W	Part enters Start Up mode - part is reset
	R	Start Up mode will immediately transition to Low Power mode
10b	W	Part enters Low Power mode
	R	Part is in Low Power mode
11b	N/A	Will not occur - The state is discarded
		Will not occur - The state is discarded

Table 13. Trigger States

D[5:0]	Read/Write	Status
D[5]	R/W	1 = Trigger 2 Disabled, 0 = Trigger 2 Enabled
D[4]		1 = Trigger 1 Disabled, 0 = Trigger 1 Enabled
D[3]		1 = Trigger 0 Disabled, 0 = Trigger 0 Enabled
D[2]	W	1 = Load Bits to Trigger 2, Trigger 2 states is Disabled
D[1]		1 = Load Bits to Trigger 1, Trigger 1 states is Disabled
D[0]		1 = Load Bits to Trigger 0, Trigger 0 states is Disabled

Package Dimensions

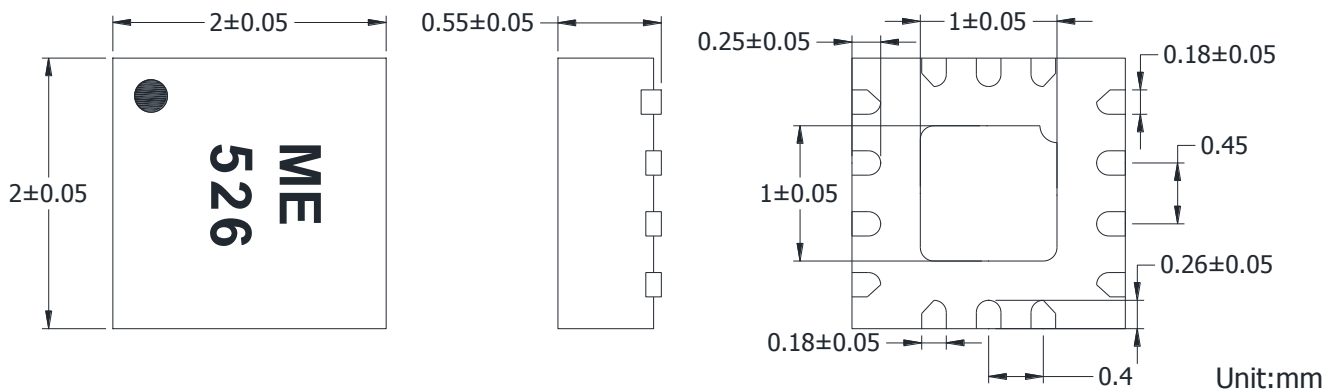

Solder land pattern

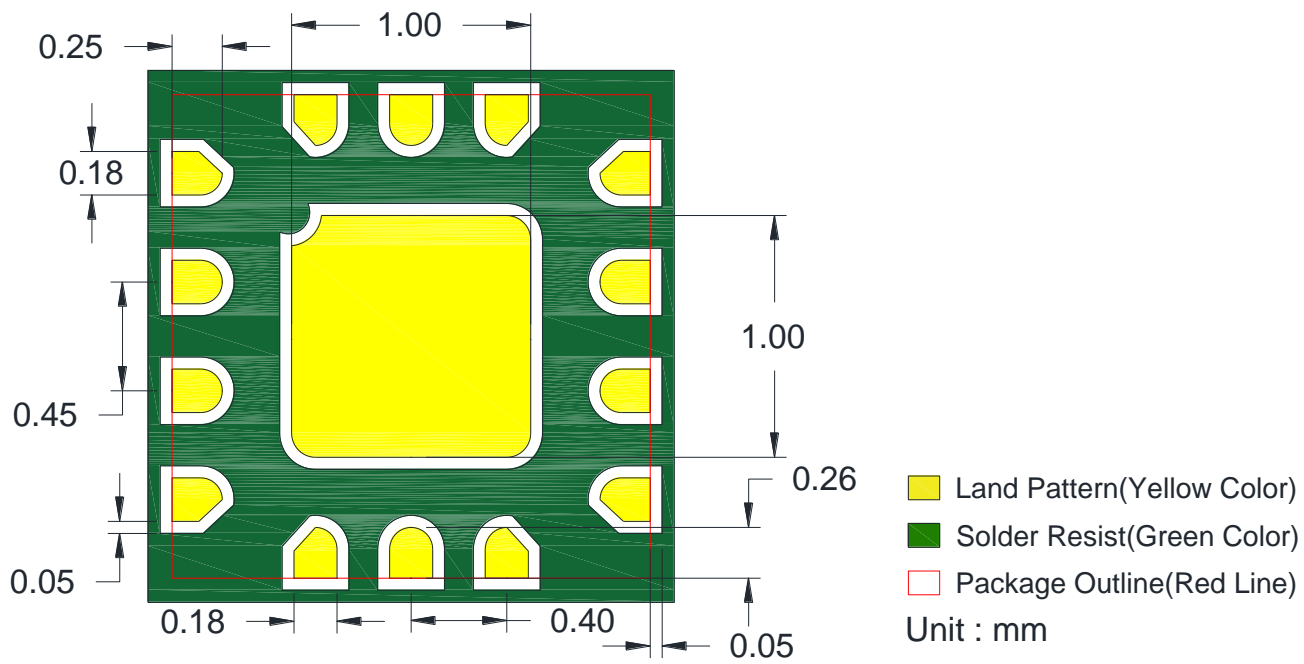

Reliability test

TEST	PROCEDURE / TEST METHOD	REQUIREMENT
Solderability JIS C 0050-4.6 JESD22-B102D	*Solder bath temperature : $255 \pm 5^{\circ}\text{C}$ *Immersion time : 5 ± 0.5 sec Solder : Sn3Ag0.5Cu for lead-free	At least 95% of a surface of each terminal electrode must be covered by fresh solder.
High temperature JIS C 0021	*Temperature : $90^{\circ}\text{C} \pm 2^{\circ}\text{C}$ *Test duration : 1000+24/-0 hours Measurement to be made after keeping at room temperature for 24 ± 2 hrs	No mechanical damage. Electrical specification shall satisfy the descriptions in electrical characteristics under the operational temperature range within $-30 \sim 90^{\circ}\text{C}$.
Low temperature JIS C 0020	*Temperature : $-30^{\circ}\text{C} \pm 2^{\circ}\text{C}$ *Test duration : 1000+24/-0 hours Measurement to be made after keeping at room temperature for 24 ± 2 hrs	No mechanical damage. Electrical specification shall satisfy the descriptions in electrical characteristics under the operational temperature range within $-30 \sim 90^{\circ}\text{C}$.
Temperature cycle JIS C 0025	1. 30 ± 3 minutes at $-30 \pm 3^{\circ}\text{C}$, 2. 10~15 minutes at room temperature, 3. 30 ± 3 minutes at $+90 \pm 3^{\circ}\text{C}$, 4. 10~15 minutes at room temperature, Total 100 continuous cycles Measurement to be made after keeping at room temperature for 24 ± 2 hrs	No mechanical damage. Electrical specification shall satisfy the descriptions in electrical characteristics under the operational temperature range within $-30 \sim 90^{\circ}\text{C}$.
High temperature operation life (HTOL)	*Temperature : 90°C *VDD = 4.8V *Time : 1000+24/-0 hrs. Measurement to be made after keeping at room temperature for 24 ± 2 hrs	No mechanical damage. Electrical specification shall satisfy the descriptions in electrical characteristics under the operational temperature range within $-30 \sim 90^{\circ}\text{C}$.

Soldering condition

Typical examples of soldering processes that provide reliable joints without any damage are given in Figure 11.

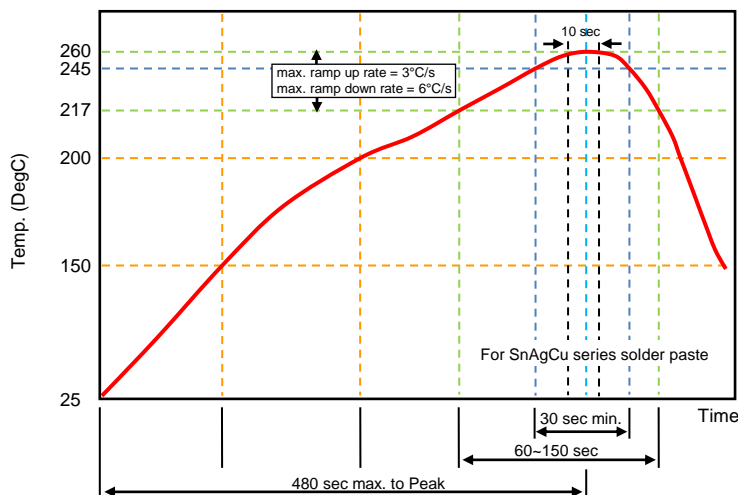

Figure 11. Infrared soldering profile

Approval Sheet

Ordering code

RF	ASW	H	526B	T
RF module RF: Walsin RF Switch Device	Module type ASW: Antenna Switch	Application H: SP6T	Design Code	Packing T: Taping

Minimum Ordering Quantity: 3000 pcs per reel.

Packaging

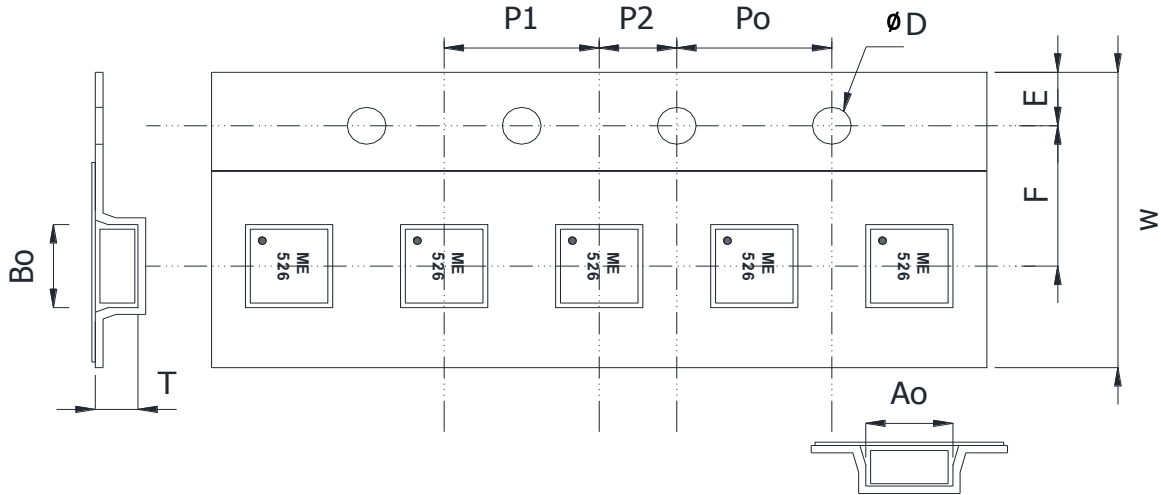

Plastic Tape specifications (unit :mm)

Index	Ao	Bo	øD	T	W
Dimension (mm)	2.15 ± 0.10	2.15 ± 0.10	1.50 ± 0.05	0.95 ± 0.10	8.0 ± 0.10
Index	E	F	Po	P1	P2
Dimension (mm)	1.75 ± 0.10	3.50 ± 0.05	4.00 ± 0.10	4.00 ± 0.10	2.00 ± 0.05

Reel dimensions

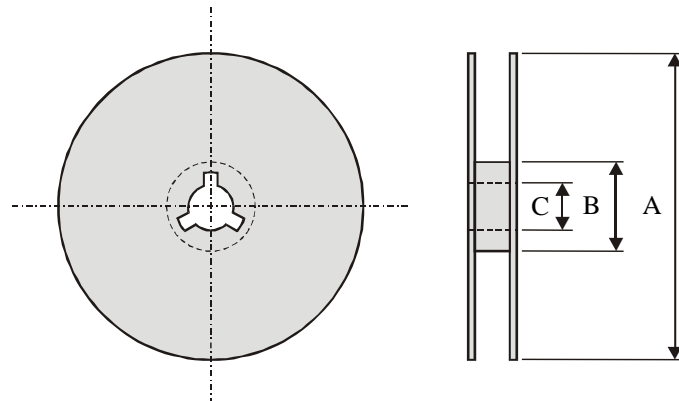

Index	A	B	C
Dimension (mm)	Φ178.0	Φ60.0	Φ13.0

Taping Quantity : 3000 pieces per 7" reel

Caution of handling

Limitation of Applications

Please contact us before using our products for the applications listed below which require especially high reliability for the prevention of defects, which might directly cause damage to the third party's life, body or property.

- (1) Aircraft equipment
- (2) Aerospace equipment
- (3) Undersea equipment
- (4) Medical equipment
- (5) Disaster prevention / crime prevention equipment
- (6) Traffic signal equipment
- (7) Transportation equipment (vehicles, trains, ships, etc.)
- (8) Applications of similar complexity and /or reliability requirements to the applications listed in the above.

Storage condition

- (1) Products should be used in 6 months from the day of WAL SIN outgoing inspection, which can be confirmed.
- (2) Storage environment condition.
 - Products should be storage in the warehouse on the following conditions.
 - Temperature : -10 to +40°C
 - Humidity : 30 to 70% relative humidity
 - Don't keep products in corrosive gases such as sulfur. Chlorine gas or acid or it may cause oxidization of electrode, resulting in poor solderability.
 - Products should be storage on the palette for the prevention of the influence from humidity, dust and son on.
 - Products should be storage in the warehouse without heat shock, vibration, direct sunlight and so on.
 - Products should be storage under the airtight packaged condition.

单击下面可查看定价，库存，交付和生命周期等信息

[>>Walsin Technology\(华新科技\(华科\)\)](#)