

APPROVAL SHEET

RF Switch Series – RoHS Compliance

SP3T GPIO Switch

Halogens Free Product

Any2G/3G/4G Band for TRx system

P/N: RFASWMH6373ATF09

*Contents in this sheet are subject to change without prior notice.

Approval Sheet

FEATURES

- Low Insertion Loss : 0.5dB typ. @ 3.0GHz
- High Isolation : 30dB typ. @ 3.0GHz
- P_{0.1dB} compression point : 37dBm typ. @ 3.0GHz
- Low control voltage : 1.65 to 4.8 V
- Miniature footprint : 2.0 x 2.0 x 0.55 mm³
- Moisture Sensitive Level 3 (MSL3)

Description

- The RFASWMH6373ATF09 is a CMOS SOI (Silicon On Insulator) Single Pole, Triple Throw (SP3T) high power switch that operating at 0.5-6.0 GHz. The RFASWMH6373ATF09 is manufactured in a QFN-12 (2.0x2.0x0.55mm³) package.
- The RFASWMH6373ATF09 features very high isolation with very low DC power consumption.
- The RFASWMH6373ATF09 has ESD protection devices to achieve excellent ESD performances. No DC Blocking capacitors are required for all RF ports unless DC is biased externally

Application

- Multi-mode 2G/3G, LTE application transmit/receive system
- WLAN 802.11b/g networks
- ISM band radios

Block Diagram and Pin Out (Top View)

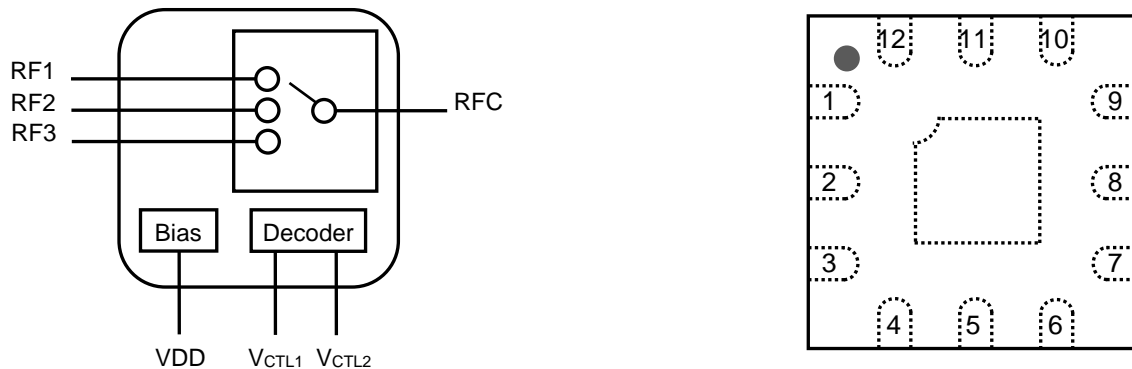

Pin Names and Descriptions

Pin	Name	Description	Pin	Name	Description
1	RF1	RF path 1	7	GND	Ground
2	GND	Ground	8	GND	Ground
3	RF3	RF path 3	9	RF2	RF path 2
4	V _{CTL1}	DC control voltage 1	10	GND	Ground
5	V _{CTL2}	DC control voltage 2	11	RFC	RF common port
6	VDD	DC power supply	12	GND	Ground

Approval Sheet

Application Circuit

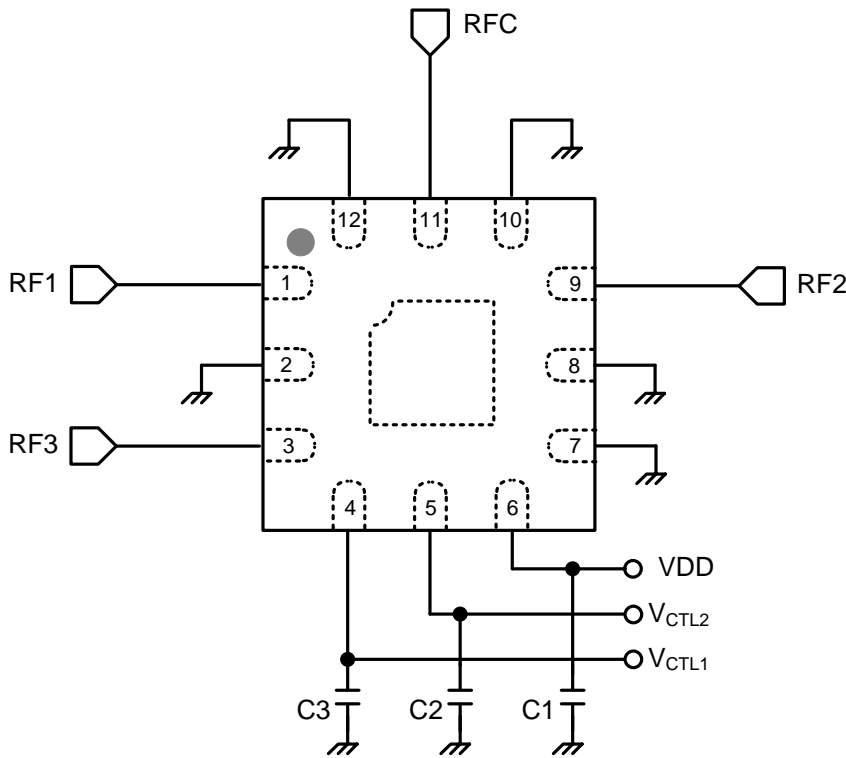

Parts List

Parts No.	Value
C1-C3	100 pF

Absolute Maximum Ratings

Parameter	Symbol	Minimum	Maximum	Units
RFx Input Power	Pin		+37	dBm
DC Supply Voltage	VDD	+2.5	+4.8	V
DC Control Voltage	VCTL	+1.65	+3.3	V
Storage temperature	T _{STG}	-40	+125	°C
Operating temperature	T _{OP}	-40	+85	°C

Exceeding absolute maximum ratings may cause permanent damage. Operation between operating range maximum and absolute maximum for extended periods may reduce reliability.

Approval Sheet

Electrical Specifications

(Top= 25°C, VDD=2.8V, V_{CTL}=0/1.8V, Characteristic Impedance Z₀= 50 Ω, Unless Otherwise Noted)

Parameter	Symbol	Test Condition	Min.	Typ.	Max.	Units
RF Specifications						
Operating frequency	f		0.5		6.0	GHz
Insertion loss (RFC to RF1/2/3 port)	IL	0.5 ~ 1.0 GHz		0.32	0.45	dB
		1.0 ~ 2.2 GHz		0.40	0.70	dB
		2.2 ~ 3.0 GHz		0.50	0.75	dB
		4.9 ~ 6.0 GHz		0.80	1.10	dB
Isolation (RFC to RF1/2/3 port)	Iso	0.5 ~ 1.0 GHz	32	38		dB
		1.0 ~ 2.2 GHz	25	33		dB
		2.2 ~ 3.0 GHz	20	30		dB
		4.9 ~ 6.0 GHz	15	22		dB
On state match	VSWR	0.5 ~ 6.0 GHz		1.4	2.0	-
Input Power 0.1dB Compression Point	P _{0.1dB}	0.5 ~ 6.0 GHz		+35		dBm
RFx Harmonics	2f ₀	PIN = +20dBm, f = 0.5 ~ 3.0GHz		+90		dBc
	3f ₀	PIN = +20dBm, f = 0.5 ~ 3.0GHz		+90		dBc
DC Specification (Decoder)						
Supply Voltage	VDD		2.5	2.8	4.8	V
Supply Current	I _{DD}	VDD= 3.5V		80		μA
Control Voltage(High)	V _{CTL}		1.65	1.8	3.3	V
Control Voltage(Low)	V _{CTL}		0		0.4	V
Control Current	I _{CTL}	V _{CTL} = 1.8V		1		μA
Switching Specification						
Switching speed	T _{SW}	50% V _{CTL} to 90/10% RF		3.5	7	μs

Note : All measurements made in a 50Ω system with 0/+1.8V control voltages, unless otherwise specified.

Logic Table for Switch On-Path (High=1.8V ,Low= 0V)

V _{c1}	V _{c2}	RF1	RF2	RF3
0	1	on	off	off
1	0	off	on	off
1	1	off	off	on
0	0	Shutdown		

Approval Sheet

Package Dimensions

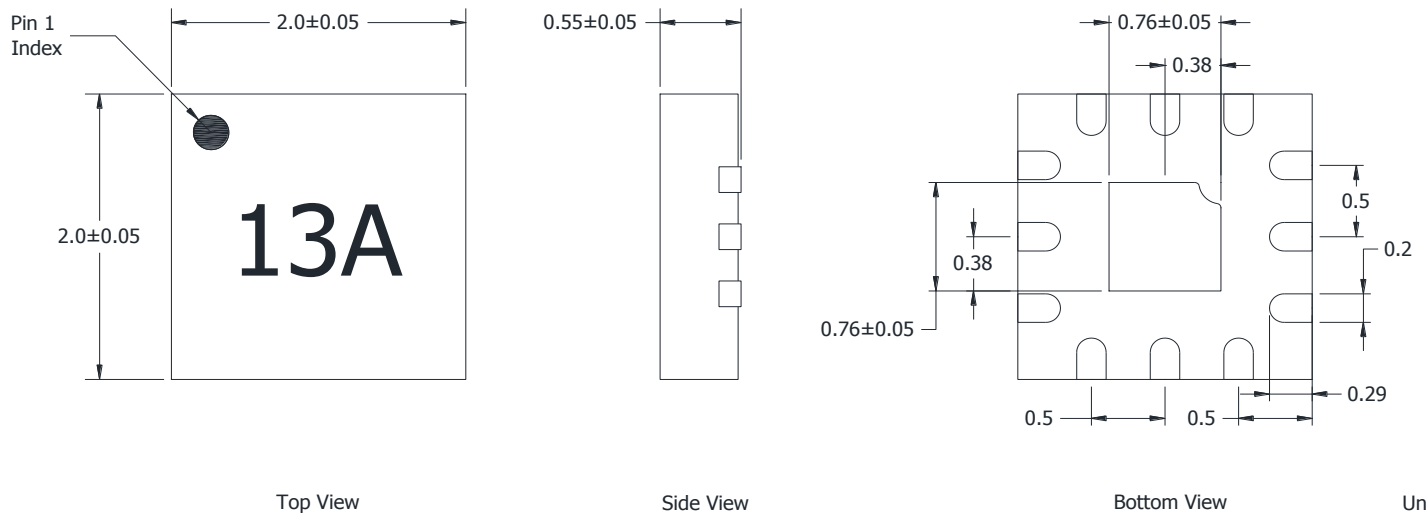

Solder Land Pattern

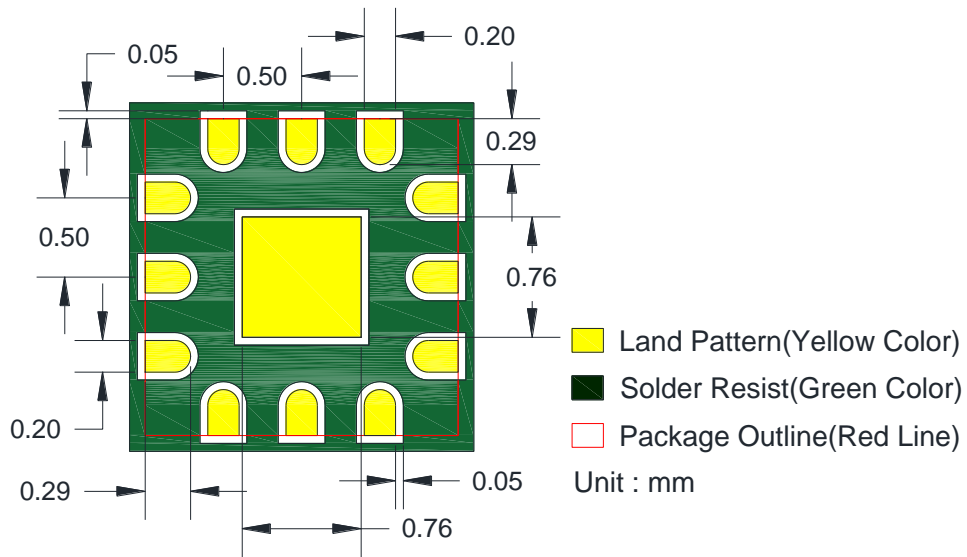

Approval Sheet

Reliability test

TEST	PROCEDURE / TEST METHOD	REQUIREMENT
Solderability JIS C 0050-4.6 JESD22-B102D	*Solder bath temperature : $255 \pm 5^{\circ}\text{C}$ *Immersion time : 5 ± 0.5 sec Solder : Sn3Ag0.5Cu for lead-free	At least 95% of a surface of each terminal electrode must be covered by fresh solder.
High temperature JIS C 0021	*Temperature : $90^{\circ}\text{C} \pm 2^{\circ}\text{C}$ *Test duration : $1000+24/-0$ hours Measurement to be made after keeping at room temperature for 24 ± 2 hrs	No mechanical damage. Electrical specification shall satisfy the descriptions in electrical characteristics under the operational temperature range within $-30 \sim 90^{\circ}\text{C}$.
Low temperature JIS C 0020	*Temperature : $-30^{\circ}\text{C} \pm 2^{\circ}\text{C}$ *Test duration : $1000+24/-0$ hours Measurement to be made after keeping at room temperature for 24 ± 2 hrs	No mechanical damage. Electrical specification shall satisfy the descriptions in electrical characteristics under the operational temperature range within $-30 \sim 90^{\circ}\text{C}$.
Temperature cycle JIS C 0025	1. 30 ± 3 minutes at $-30 \pm 3^{\circ}\text{C}$, 2. 10~15 minutes at room temperature, 3. 30 ± 3 minutes at $+90 \pm 3^{\circ}\text{C}$, 4. 10~15 minutes at room temperature, Total 100 continuous cycles Measurement to be made after keeping at room temperature for 24 ± 2 hrs	No mechanical damage. Electrical specification shall satisfy the descriptions in electrical characteristics under the operational temperature range within $-30 \sim 90^{\circ}\text{C}$.
High temperature operation life (HTOL)	*Temperature : 90°C *VDD = 4.8V *Time : $1000+24/-0$ hrs. Measurement to be made after keeping at room temperature for 24 ± 2 hrs	No mechanical damage. Electrical specification shall satisfy the descriptions in electrical characteristics under the operational temperature range within $-30 \sim 90^{\circ}\text{C}$.

Soldering condition

Typical examples of soldering processes that provide reliable joints without any damage are given in Figure 11.

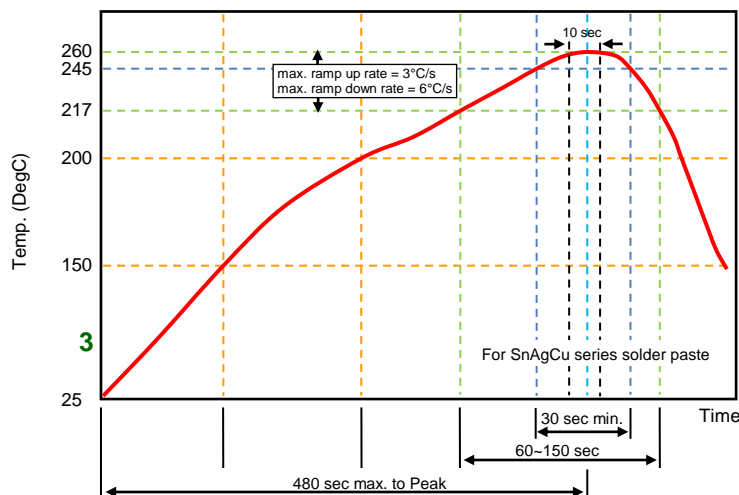

Figure 11. Infrared soldering profile

Approval Sheet

Ordering code

RF	ASW	M	H6373A	T
RFmodule RF: Walsin RF Switch Device	Module type ASW: Antenna Switch	Application M:SP3T	Design Code	Packing T: Taping

Minimum Ordering Quantity: 3000 pcs per reel.

Packaging

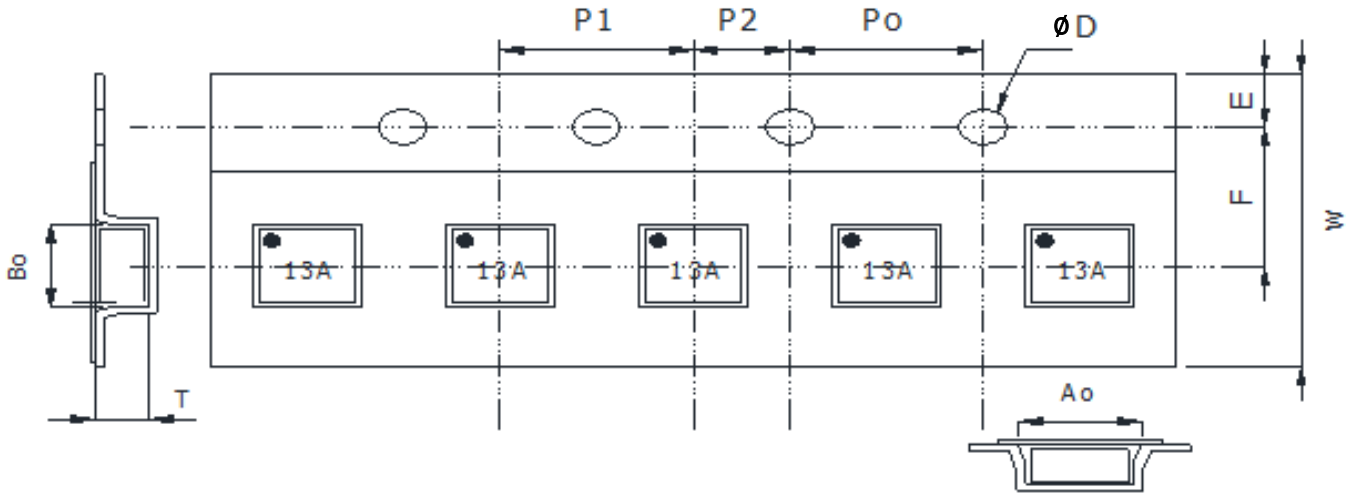

Plastic Tape specifications (unit :mm)

Index	Ao	Bo	φD	T	W
Dimension (mm)	2.25± 0.05	2.25± 0.05	1.50± 0.10	0.70± 0.05	8.00 ± 0.20
Index	E	F	Po	P1	P2
Dimension (mm)	1.75 ± 0.10	3.50 ± 0.05	4.00 ± 0.20	8.00 ± 0.10	4.00 ± 0.05

Reel dimensions

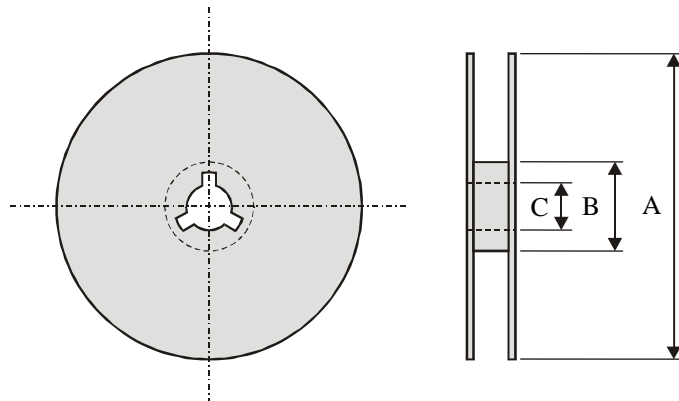

Index	A	B	C
Dimension (mm)	Φ178.0	Φ54.0	Φ13.2

TapingQuantity:3000 pieces per 7" reel

Approval Sheet

Caution of handling

Limitation of Applications

Please contact us before using our products for the applications listed below which require especially high reliability for the prevention of defects, which might directly cause damage to the third party's life, body or property.

- (1) Aircraft equipment
- (2) Aerospace equipment
- (3) Undersea equipment
- (4) Medical equipment
- (5) Disaster prevention / crime prevention equipment
- (6) Traffic signal equipment
- (7) Transportation equipment (vehicles, trains, ships, etc.)
- (8) Applications of similar complexity and /or reliability requirements to the applications listed in the above.

Storage condition

- (1) Products should be used in 6 months from the day of WALSIN outgoing inspection, which can be confirmed.
- (2) Storage environment condition.
 - Products should be storage in the warehouse on the following conditions.
 - Temperature : -10 to +40°C
 - Humidity : 30 to 70% relative humidity
 - Don't keep products in corrosive gases such as sulfur. Chlorine gas or acid or it may cause oxidization of electrode, resulting in poor solderability.
 - Products should be storage on the palette for the prevention of the influence from humidity, dust and son on.
 - Products should be storage in the warehouse without heat shock, vibration, direct sunlight and so on.
 - Products should be storage under the airtight packaged condition.

单击下面可查看定价，库存，交付和生命周期等信息

[>>Walsin Technology\(华新科技\(华科\)\)](#)