

# APPROVAL SHEET

**RF SAW Filter Series – RoHS Compliance**

**WLAN (BlueTooth / WiFi)**

**2400~2500 MHz Band Working Frequency**

**P/N : SF11092450A04T**

## Approval Sheet

### Features

- Low loss, Low pass band ripple
- Single to single operation
- Impedance at input and output 50 Ohm
- Package for **S**urface **M**ount **T**echnology (SMT)
- **E**lectrostatic **S**ensitive **D**evice (ESD)
- Ultra small package : (1.1mm × 0.9mm × 0.5mm)
- RoHS Compliance
- **M**oisture **S**ensitive **L**evel 3 (MSL3)

### Application

- WLAN (BlueTooth / WiFi)

### Package Dimensions

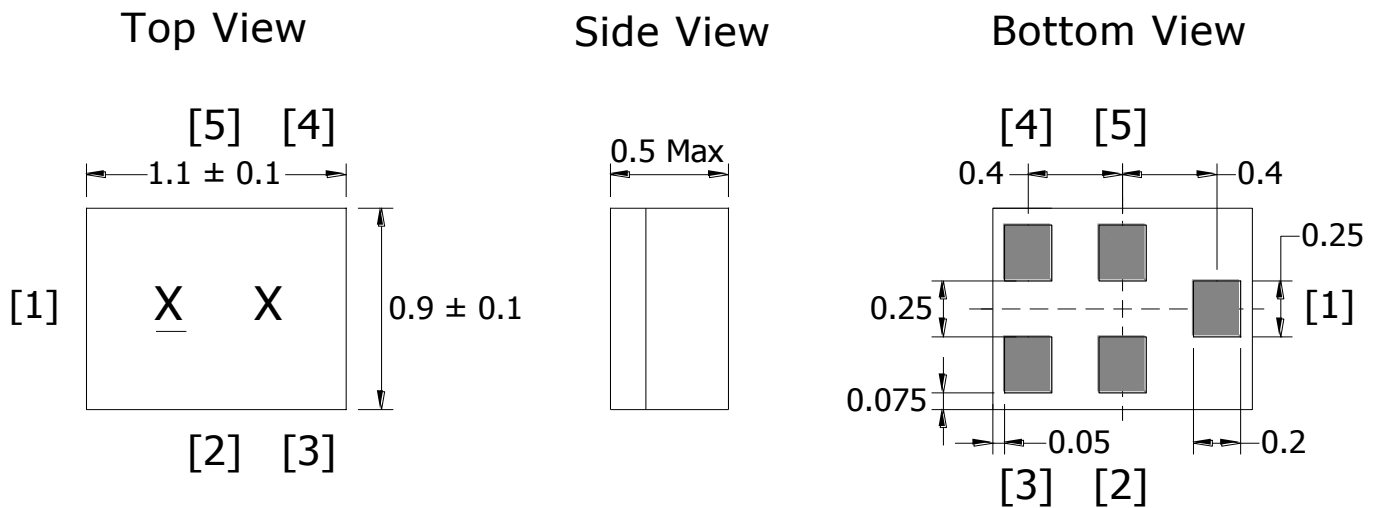

Unit : mm

#### Pin Descriptions

Pin	Description	Pin	Description
[1]	Input	[4]	Output
[2]	GND	[5]	GND
[3]	GND		

#### Marking Descriptions

Marking	Description
<u>X</u>	Series Number
X	Date Code (Year+Month)

### Test Circuit

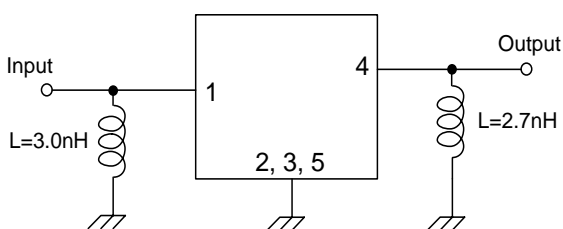

## Approval Sheet

### Electrical Specifications

Item		Frequency (MHz)	Specification			Unit
			Min	Typ	Max	
Center frequency		-	-	2450	-	MHz
Insertion loss		2400 ~ 2500	-	1.5	2.5	dB
Pass band ripple		2400 ~ 2500	-	0.55	1.5	dB <sub>p-p</sub>
VSWR	Input	2400 ~ 2500	-	1.9	2.3	-
	Output		-	1.9	2.3	-
Absolute attenuation		D.C ~ 960	35	53	-	dB
		960 ~ 1570	35	45	-	dB
		1570 ~ 1580	35	45	-	dB
		1580 ~ 1710	35	43	-	dB
		1710 ~ 1910	33	38	-	dB
		1910 ~ 1980	35	42	-	dB
		2110 ~ 2170	28	32	-	dB
		2640 ~ 3000	20	25	-	dB
		3000 ~ 4800	15	20	-	dB
		4800 ~ 5000	15	19	-	dB
5000 ~ 6000	15	18	-	dB		
Terminating impedance		Input	50			Ohm
		Output	50			Ohm

Note : With matching network (Ref. testing environment circuit as shown above).

### Absolute Maximum Ratings

Item	Rating	Unit
DC permissive voltage	0	V
Maximum input power	28	dBm
Operating temperature range	-40 ~ +85	°C
Storage temperature range	-40 ~ +85	°C

Approval Sheet

Typical Frequency Response

Input-Output insertion

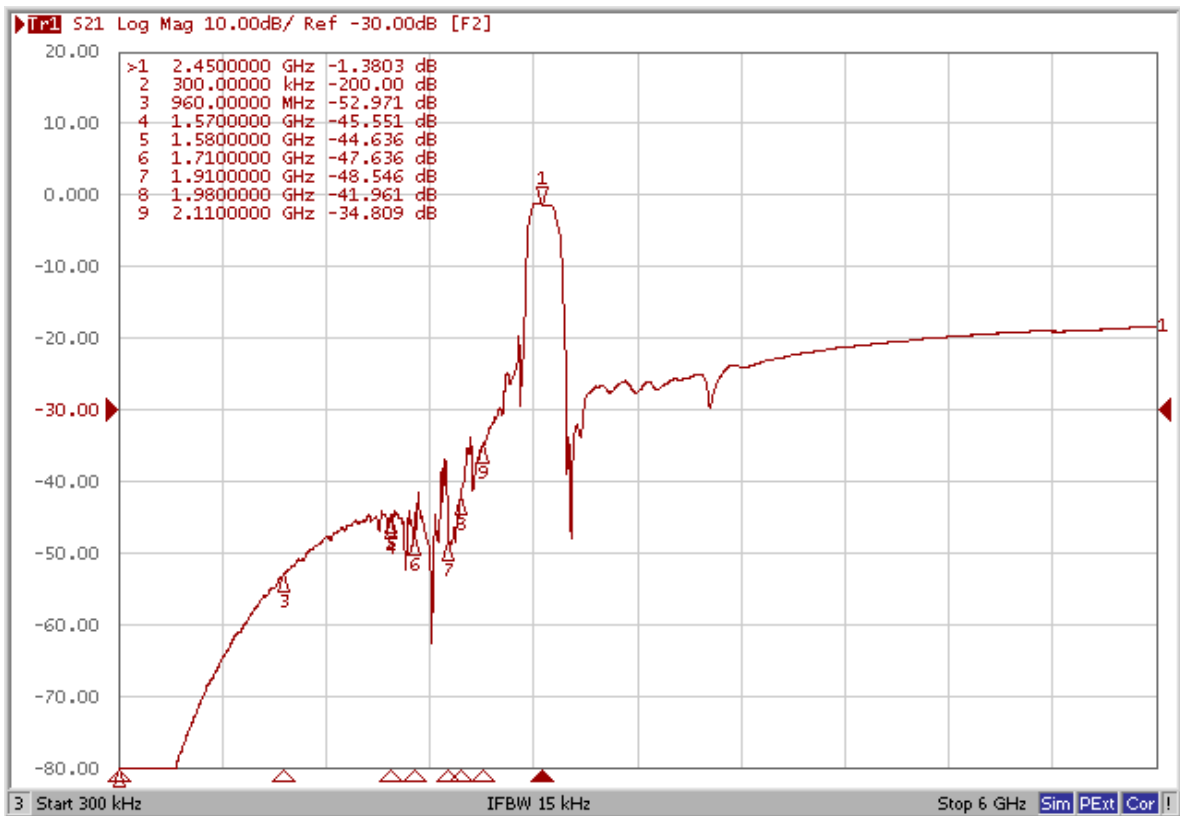
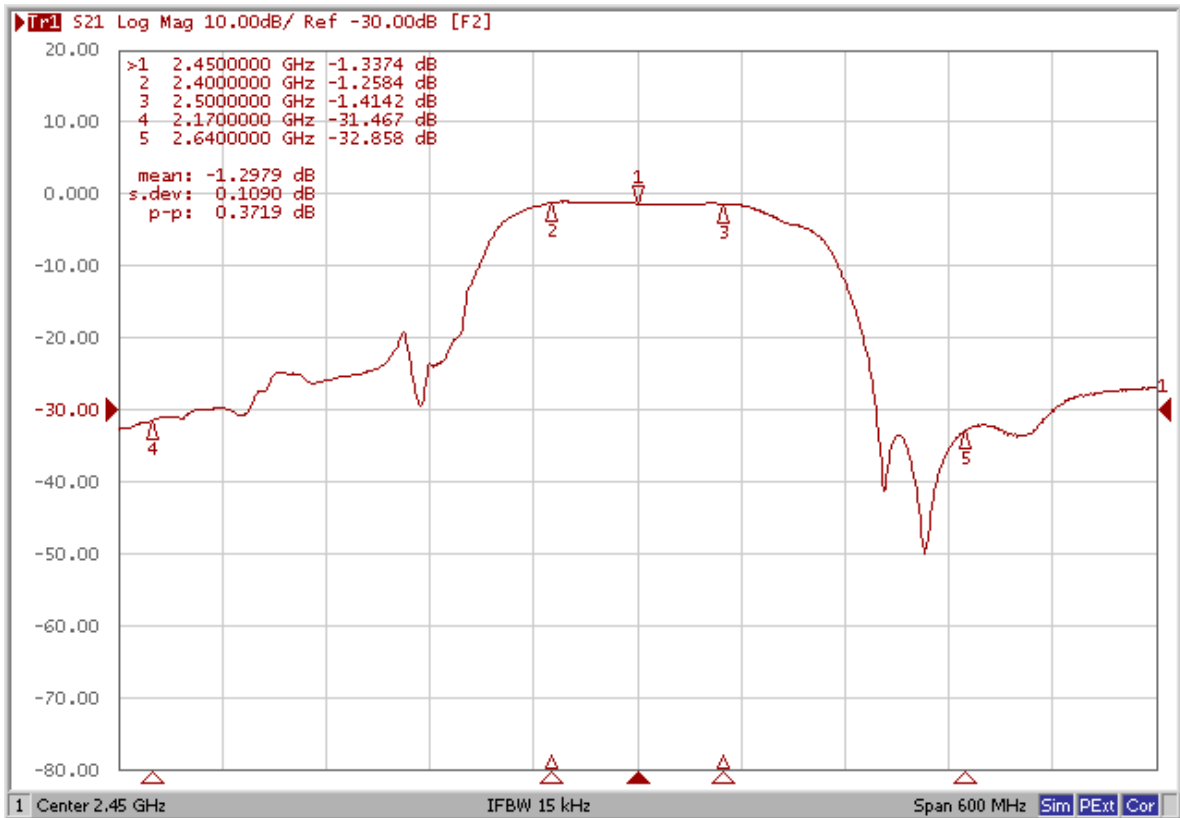

■ VSWR

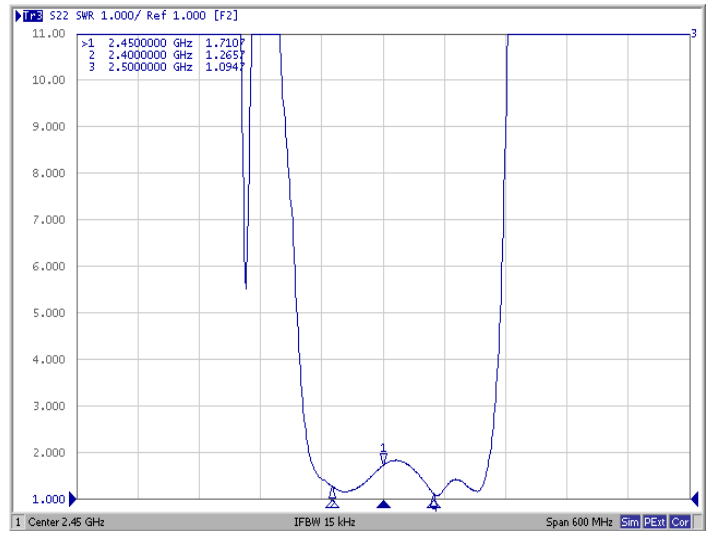
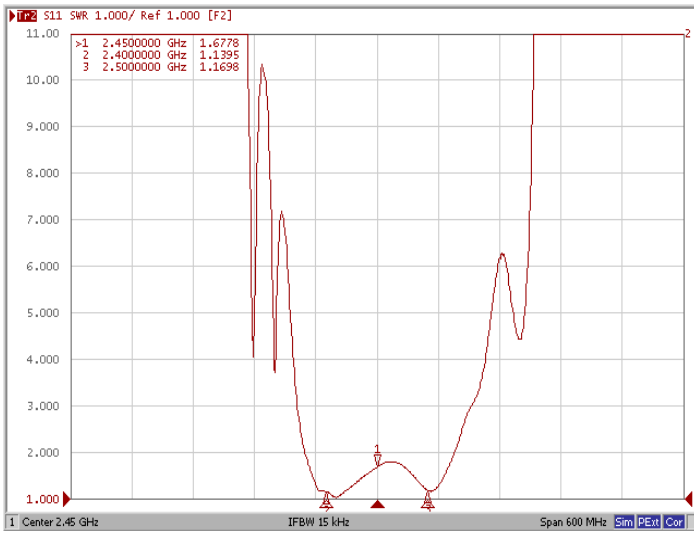

■ Smith chart

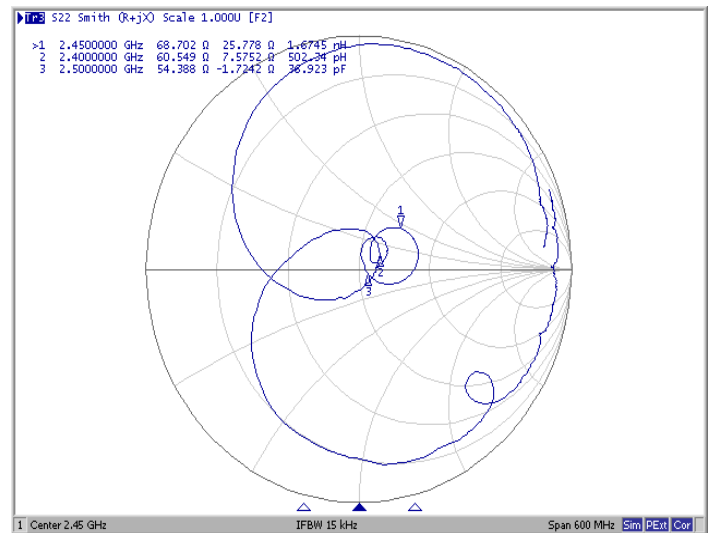
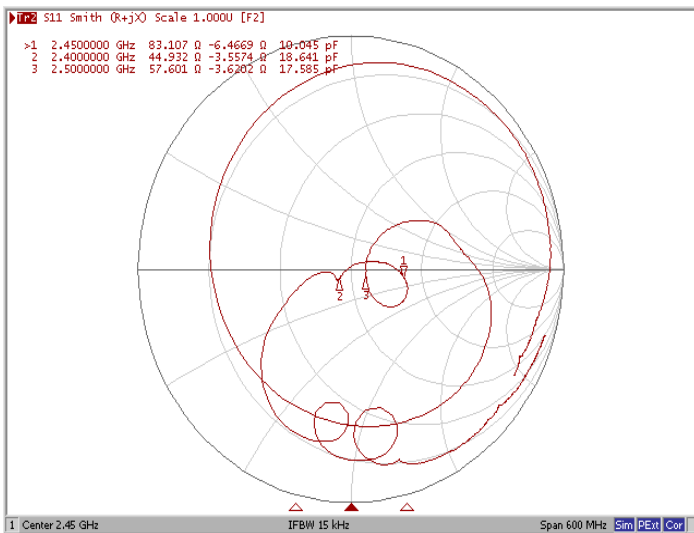

**Approval Sheet**  
**Solder Land Pattern**

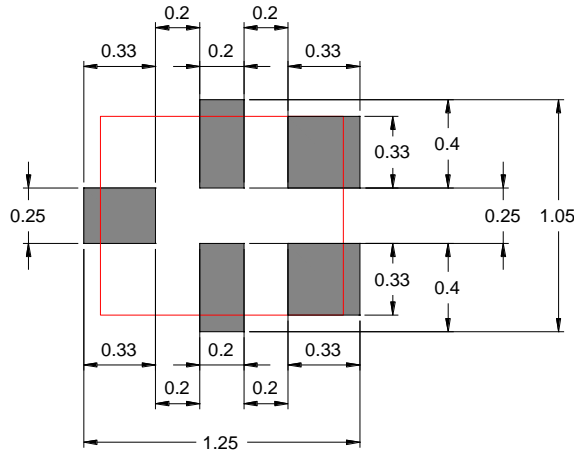

□ Package Outline

■ Land Pattern

Unit : mm

**Reliability Test**

Test	Procedure/Test method	Requirements
<b>Vibration</b>	*Frequency : 10Hz ~ 55Hz *Total amplitude : 1.5mm *Sweep period : 1.0 minute *Vibration directions : 3 mutually perpendicular *Duration : 2 hours / direct	After the test, specimen would be kept at room temperature for 2 hours.  And then the measured values shall fulfill the Electrical Specifications.
<b>Drop test</b>	*Height : 1.0 m *Test surface : Rigid surface of concrete or steel *Times : 10 times	
<b>Static humidity</b>	*Temperature : +70°C± 2°C *Relative humidity : 90% *Duration : 96 hours	
<b>Temperature cycling</b>	1. 30 minutes at -40°C, 2. 30 minutes at +85°C, *cycle time : 100 times	
<b>High temperature exposure</b>	*Exposure temperature : 85°C± 5°C *Exposure duration : 240 hours	
<b>Low temperature exposure</b>	*Exposure temperature : -40°C± 5°C *Exposure duration : 240 hours	
<b>Reflow soldering</b>	*Temperature / Duration : 275°C / 10sec *Total time : 6 minute (IR-reflow)	

**Approval Sheet**  
Soldering Condition

**260°C Suggested Solder Reflow**

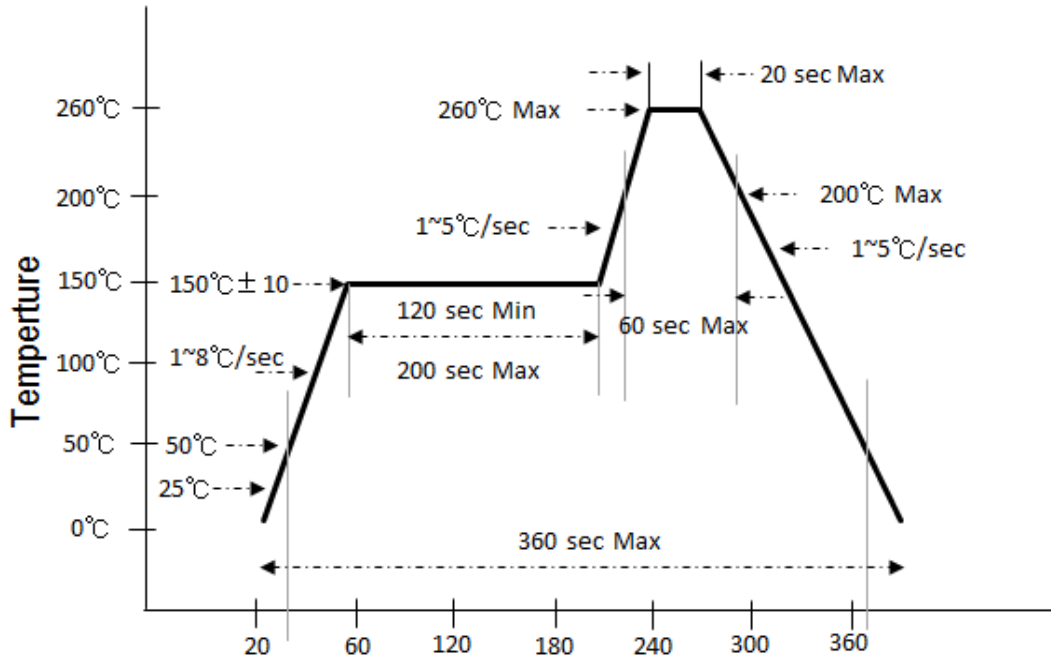

**Ordering Code**

SF	1109	2450	A	04	T
<b>Series</b> SF : SAW Filter	<b>Dimension code</b> Per2 digits of Length, Width 1109= Length 1.1mm Width 0.9mm	<b>Frequency</b> 2450 : Center Freq (2450MHz)	<b>Application</b> A : 2.4GHz (ISM Band)	<b>Serial Number</b> Design Code	<b>Packing</b> T : Reeled

**Packing**

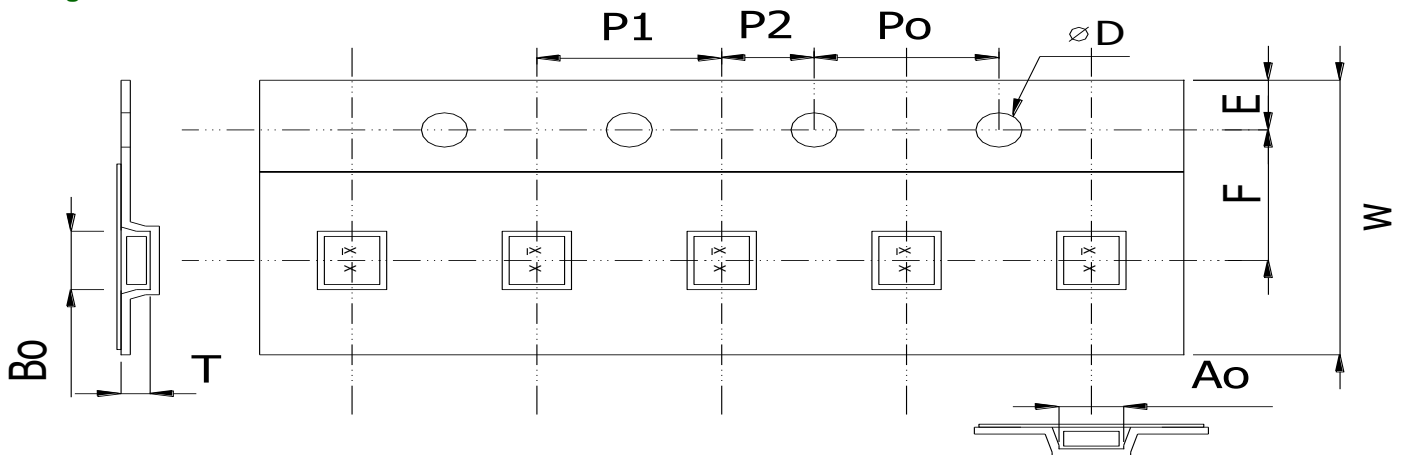

Plastic Tape specifications

Index	Ao	Bo	∅D	T	W
Dimension (mm)	1.10 ± 0.10	1.3 ± 0.10	1.55 ± 0.05	0.7 ± 0.10	8.0 ± 0.20
Index	E	F	Po	P1	P2
Dimension (mm)	1.75 ± 0.10	3.50 ± 0.05	4.00 ± 0.10	4.00 ± 0.10	2.0 ± 0.10

## Approval Sheet

### Reel Dimensions

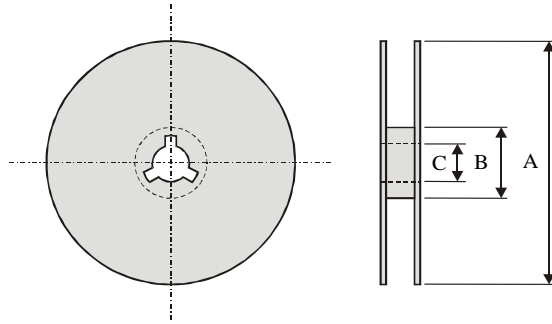

Index	A	B	C
Dimension (mm)	$\Phi 180.0 +0/-1.5$	$\Phi 66.0 \pm 0.5$	$\Phi 13.0 \pm 0.2$

Note : The product shall be packed properly not to be damaged during transportation and storage.  
Taping Quantity : 5000 pieces per 7" reel

### Caution Of Handling

#### Limitation of Applications

Please contact us before using our products for the applications listed below which require especially high reliability for the prevention of defects, which might directly cause damage to the third party's life, body or property.

- (1) Aircraft equipment
- (2) Aerospace equipment
- (3) Undersea equipment
- (4) Medical equipment
- (5) Disaster prevention / crime prevention equipment
- (6) Traffic signal equipment
- (7) Transportation equipment (vehicles, trains, ships, etc.)
- (8) Applications of similar complexity and /or reliability requirements to the applications listed in the above.

### Storage Condition

- (1) Products should be used in 6 months from the day of WALSIN outgoing inspection, which can be confirmed.
- (2) Storage environment condition.
  - Products should be storage in the warehouse on the following conditions.
  - Temperature : -10 to +40°C
  - Humidity : 30 to 70% relative humidity
  - Don't keep products in corrosive gases such as sulfur. Chlorine gas or acid or it may cause oxidization of electrode, resulting in poor solderability.
  - Products should be storage on the palette for the prevention of the influence from humidity, dust and son on.
  - Products should be storage in the warehouse without heat shock, vibration, direct sunlight and so on.
  - Products should be storage under the airtight packaged condition.

### Important Notes

- (1) This device should not be used in any type of fluid such as water, oil, organic solvent, etc.
- (2) Cleaning agent isopropyl alcohol and ethyl alcohol can be used.
- (3) As rapid temperature change for cleaning after reflow soldering might be a cause of degradation or destruction, clean this component after confirming that temperature of this component goes down to room temperature.
- (4) As ultrasonic vibration might be a cause of degradation or destruction, do not use ultrasonic cleaning.
- (5) This device follows JEDEC standards for moisture classifications.  
The following this device is classified as **Moisture Sensitive Level 3**  
This device is moisture sensitive and need to be handled within proper MSL 3 guidelines to avoid damage from moisture absorption and exposure to solder reflow temperatures that can result in yield and reliability degradation
- (6) This is an **Electrostatic Sensitive Device**.  
Please avoid static voltage during operation and storage.
- (7) Sudden change of temperature shall be avoided, deterioration of the characteristics can occur.
- (8) If any malfunction due to designing or manufacturing which is out of specification occurs within one year after the products have been delivered, the maker should exchange the defective products.



单击下面可查看定价，库存，交付和生命周期等信息

[>>Walsin Technology\(华新科技\(华科\)\)](#)

[>>点击查看相关商品](#)