

CERAMIC DISC CAPACITOR SAFETY RECOGNIZED, AC
SERIES(pitch5mm)- Small Size

POE-D22-01-E-07

Ver:07

Page:1 / 20

HF

PRODUCT SPECIFICATION

PRODUCT: CERAMIC DISC CAPACITOR SAFETY
RECOGNIZED For PITCH: 5mm

TYPE: AC SERIES (Small Size)

CUSTOMER:

DOC. NO.: POE-D22-01-E-07

符合 RoHS&HF 及其他環保要求；金屬電鍍層不含六價鉻
RoHS &HF& Requirements of Environmental; Prohibit
containing Cr+6 in the plating with metal

APPROVED BY CUSTOMER

VENDOR :

- WALSIN TECHNOLOGY CORPORATION**
566-1, KAO SHI ROAD, YANG-MEI
TAO-YUAN, TAIWAN
- PAN OVERSEAS (GUANGZHOU) ELECTRONIC CO.,LTD.**
NO.277,HONG MING ROAD,EASTERN SECTION,
HUANGPU DISTRICT ,GUANG ZHOU,CHINA
- DONGGUAN WALSIN TECHNOLOGY ELECTRONICS CO., LTD.**
NO.638, MEI JING WEST ROAD,XINIUPO,ADMINISTRATIVE ZONE,DALANGTOWN,DONGGUAN
CITY, GUANGDONG PROVINCE

MANUFACTURE SITE :

- PAN OVERSEAS (GUANGZHOU) ELECTRONIC CO.,LTD.**
NO.277,HONG MING ROAD,EASTERN SECTION,
HUANGPU DISTRICT ,GUANG ZHOU,CHINA

CERAMIC DISC CAPACITOR SAFETY RECOGNIZED, AC SERIES(pitch5mm)- Small Size	POE-D22-01-E-07	Ver:07	Page:2 / 20
---	-----------------	--------	-------------

Record of change

Date	Version	Description	page
2017/6/10	00	First edition.	All
2019/1/18	01	Revised standard NO. of VDE, SEV, SEMKO, FIMKO, NEMKO and DEMKO.	9
2019/3/12	02	Add "0AC" code for Y2:250V~ marking type.	4,8~9
2019/4/24	03	"Protrusion length": "2.0max (Or the end of lead wire may be inside the tape.)" revised to "+0.5to-1.0 (Or the end of lead wire may be inside the tape.)"	7
2019/12/11	04	1. Review the Available lead code of Lead Configuration 2. Add "8.3 Label samples"	5 14
2021/9/9	05	1. Delete Walsin & POE logo.	1
2022/4/21	06	1. Add Applied voltage in 9.3 Test condition for withstanding voltage. 2. Add 10.2 List of substances that affect the insulation strength of coating	15~16 18
2023/5/26	07	1. Revised recognized No. of SEMKO and FIMKO.	9

CERAMIC DISC CAPACITOR SAFETY RECOGNIZED, AC SERIES(pitch5mm)- Small Size	POE-D22-01-E-07	Ver:07	Page:3 / 20
--	-----------------	--------	-------------

Table of Contents

No.	Item	Page
1	Part number for SAP system	4
2	Mechanical	5
3	Part numbering/T.C/Capacitance/ Tolerance/Diameter	6
4	Taping Format	7
5	Marking	8
6	Scope	9
7	Specification and test method	10~13
8	Packing specification	14
9	Caution	15~17
10	Notice	17~18
11	Note	18
12	Soldering Recommendation	19
13	Drawing of Internal Structure and material list	20

CERAMIC DISC CAPACITOR SAFETY RECOGNIZED, AC SERIES(pitch5mm)- Small Size	POE-D22-01-E-07	Ver:07	Page:4 / 20
--	-----------------	--------	-------------

1. Part number for SAP system

(Ex.) YU 1 AC 472 M 10 0 N 3E A 5 T
 (1) (2)-1 (2)-2 (3) (4) (5) (6) (7) (8) (9) (10) (11)

(1) Temperature characteristic (identified code)

CODE	Temperature characteristic	Cap. Change
SL	SL	-1000~+350PPM/°C (+20°C~+85°C)
YP	B (Y5P)	±10%
YU	E (Y5U)	-55% to +20%

(2)-1 Rated voltage(identified by 1-figure code) : 0= X1:400V~/Y2:250V~,1=X1:440V~/Y2:300V~

(2)-2 Type(identified by 2-figure code) : AC

(3) Capacitance (identified by 3-figure code) : EX.221=220pF

(4) Capacitance tolerance (identified by code) : J:±5%,K:±10%,M:±20%

(5) Nominal body diameter dimension (Refer to “3. Part numbering/T.C/Capacitance/ Tolerance/Diameter”)

(6) Internal code: 0--Normal, other code--Special control

(7) Lead Style : Refer to “2. Mechanical”.

(8) Packing mode and lead length (identified by 2-figure code): Refer to “2. Mechanical” & “4.Taping Format”

Taping Code	Description
AN	Ammo box and product pitch : 12.7mm
AM	Ammo box and product pitch : 25.4 mm

Bulk Code	Description
03	Lead length : 3.0mm
3E	Lead length : 3.5mm
04	Lead length : 4.0mm
4E	Lead length : 4.5mm
05	Lead length : 5.0mm
20	Lead length : 20.0mm

(9) Tolerance of lead length

Code	Description	
A	±0.5 mm (only for kink lead type)	Short lead
B	±1.0 mm	Short lead
C	Min.	Long lead
D	Taping special purpose	Taping

(10) Lead space

Code	Description
5	5.0+1.0/-0.2mm

(11) Epoxy resin code

Code	Description
T	Halogen and Pb free , epoxy resin, for Cu electrode

2. Mechanical

Encapsulation : Epoxy resin, flammability UL94 V-0

Available lead code(unit: mm)

Lead type	SAP P/N (13-17)digits	Lead space (F)	Lead Length (L)	Packing	Lead Configuration
Lead style : L or B Straight lead	L03B5	5.0+1.0/-0.2	3.0 ± 1.0	Bulk	
	L3EB5		3.5 ± 1.0		
	L4EB5		4.5 ± 1.0		
	L20C5		20 min.	Tap. Ammo	
	BAND5		Refer to "4. Taping format"		
	BAMD5				
Lead style : D Vertical kink lead	D03A5	5.0+1.0/-0.2	3.0 ± 0.5	Bulk	
	D3EA5		3.5 ± 0.5		
	D05A5		5.0 ± 0.5		
	D20C5		20 min.	Tap. Ammo	
	DAND5		Refer to "4. Taping format"		
	DAMD5				
Lead style : X Outside kink lead	X03A5	5.0+1.0/-0.2	3.0 ± 0.5	Bulk	
	X3EA5		3.5 ± 0.5		
	X04A5		4.0 ± 0.5		
	X20C5		20 min.	Tap. Ammo	
	XAND5		Refer to "4. Taping format"		
	XAMD5				

* Lead diameter ϕd : 0.55 +0.1/-0.05mm

* e (Coating extension on leads): 3.0mmMax for straight lead lead style; Not exceed the kink for kink lead.

CERAMIC DISC CAPACITOR SAFETY RECOGNIZED, AC SERIES(pitch5mm)- Small Size	POE-D22-01-E-07	Ver:07	Page:6 / 20
---	-----------------	--------	-------------

3. Part numbering/T.C/Capacitance/ Tolerance/Diameter :

SAP P/N	T.C.	Capacitance	Tolerance	Dimensions (unit : mm)				
				D (max)	T (max)	F		φd
						Bulk type	Taping type	
SL*AC***J060*T	SL	10,12,15,18,20,22,24,27,30,33,36,39,47,50,51(pF)	±5%	7.0	4.5	5.0+1.0/-0.2	5.0+1.0/-0.2 (AND5)	0.55 +0.1/-0.05
SL*AC***J070*T		56,62, 68,75(pF)	±5%	8.0				
SL*AC820J080*T		82pF	±5%	9.0				
SL*AC101J090*T		100pF	±5%	10.0				
YP*AC101K050*T	Y5P	100 pF	±10%	6.0				
YP*AC151K050*T		150 pF	±10%	6.0				
YP*AC221K060*T		220 pF	±10%	7.0				
YP*AC331K050*T		330 pF	±10%	6.0				
YP*AC471K060*T		470 pF	±10%	7.0				
YP*AC561K060*T		560pF	±10%	7.0				
YP*AC681K060*T		680 pF	±10%	7.0				
YP*AC821K070*T		820 pF	±10%	8.0				
YP*AC102K070*T		1000 pF	±10%	8.0				
YU*AC102M050*T	Y5U	1000 pF	±20%	6.0				
YU*AC152M060*T		1500 pF	±20%	7.0				
YU*AC222M070*T		2200 pF	±20%	8.0				
YU*AC332M090*T		3300 pF	±20%	10.0				
YU*AC392M100*T		3900 pF	±20%	11.0				
YU*AC472M100*T		4700 pF	±20%	11.0				

4. Taping Format:

• 12.7mm pitch/lead spacing 5mm taping

Lead Code: *BAND5 & *DAND5 & *XAND5

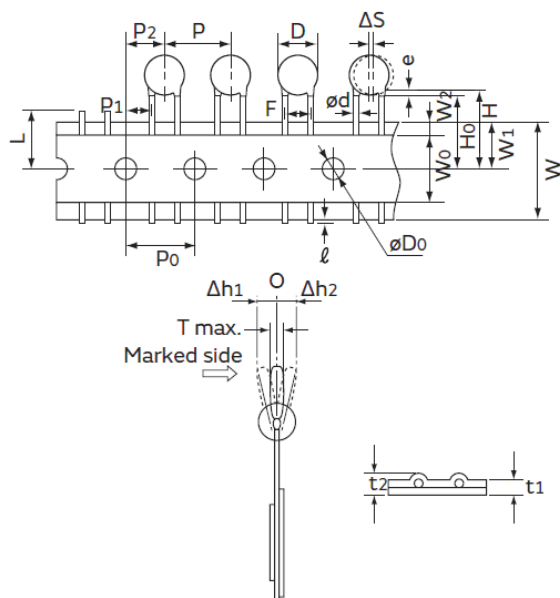

• 25.4mm pitch/lead spacing 5mm taping

Lead Code: *BAMD5 & *DAMD5 & *XAMD5

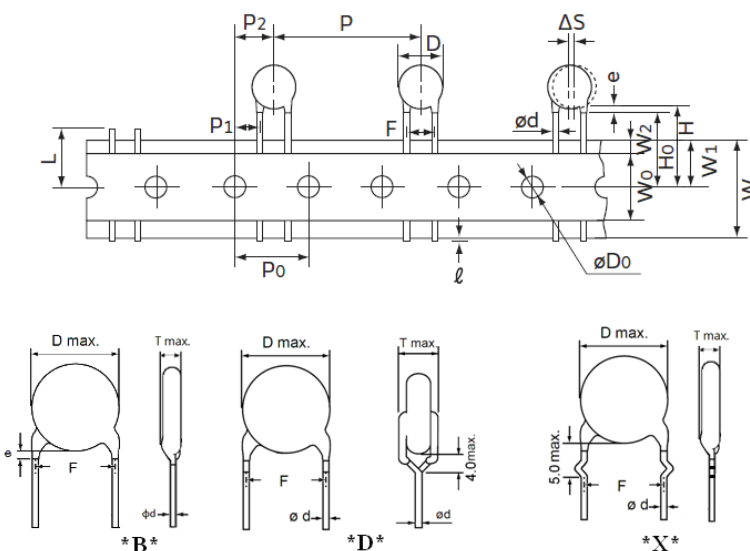

POE Part Number		*BAND5/*DAND5/*XAND5	*BAMD5/*DAMD5/*XAMD5
Item	Symbol	Dimensions (mm)	Dimensions (mm)
Pitch of component	P	12.7±1.0	25.4±2.0
Pitch of sprocket	P0	12.7±0.3	12.7±0.3
Lead spacing	F	5.0+1.0/-0.2	
Length from hole center to component center	P2	6.35±1.5	12.7 ± 1.5
Length from hole center to lead	P1	3.75±1.0	10.2±1.0
Body diameter	D	See the "3. Part numbering/T.C/Capacitance/ Tolerance/Diameter"	
Deviation along tape, left or right	△S	0±2.0	
Carrier tape width	W	18.0 +1/-0.5	
Position of sprocket hole	W1	9.0±0.5	
Lead distance between the kink and center of sprocket hole	H0	18.0+2.0/-0 For: *DAND5 / *XAND5	18.0+2.0/-0 For: *DAMD5 / *XAMD5
Lead distance between the bottom of body and the center of sprocket hole	H	20.0+1.5/-1.0 For: *BAND5	20.0+1.5/-1.0 (For: *BAMD5)
Length from the terminal of the lead wire to the edge of carrier tape	ℓ	+0.5 to -1.0 (Or the end of lead wire may be inside the hole-down tape.)	
Diameter of sprocket hole	D0	4.0±0.2	
Lead diameter	ød	0.55+0.1/-0.05	
Total tape thickness	t1	0.6±0.3	
Total thickness, tape and lead wire	t2	1.5 max.	
Deviation across tape	△h1/△h2	2.0 max.	
Portion to cut in case of defect	L	11.0 max.	
Hole-down tape width	W0	8.0 min	
Hole-down tape distortion	W2	3.0 max.	
Coating extension on leads	e	3.0 max for straight lead style; Not exceed the kink leads for kink lead.	
Body thickness	T	See the "3. Part numbering/T.C/Capacitance/ Tolerance/Diameter"	

CERAMIC DISC CAPACITOR SAFETY RECOGNIZED, AC SERIES(pitch5mm)- Small Size	POE-D22-01-E-07	Ver:07	Page:9 / 20
--	-----------------	--------	-------------

6. Scope

THIS SPECIFICATION APPLIES TO CERAMIC INSULATED CAPACITORS DISK TYPE USED IN ELECTRONIC EQUIPMENT.

- VDE /UL/CSA recognized capacitor for Antenna coupling and AC line-by-pass.X1, Y2 Capacitor based on IEC 60384-14 “UL, CSA recognized for across-the-line, line-by-pass” and antenna-isolation
- Approval Standard and Recognized No.

Safety Standard	Standard No.	Subclass	w.v.	Recognized No.
UL	ANSI/UL 60384-14:2013	X1	400VAC or 440VAC	E146544
		Y2	250VAC or 300VAC	
CSA	CAN/CSA E60384-14:2009	X1	400VAC or 440VAC	2347969
		Y2	250VAC or 300VAC	
VDE (ENEC)	EN 60384-14:2013/A1:2016 IEC 6.384-14:2013 IEC 6.384-14:2013/AMD1:2016	X1	400VAC or 440VAC	40001829
		Y2	250VAC or 300VAC	
SEV	EN 60384-14:2013 + A1:16	X1	400VAC or 440VAC	21.0555
		Y2	250VAC or 300VAC	
SEMKO	EN 60384-14:2013+A1	X1	400VAC or 440VAC	SE-S-1811994R2
		Y2	250VAC or 300VAC	
FIMKO	EN 60384-14:2013 + A1:16	X1	400VAC or 440VAC	FI/41696
		Y2	250VAC or 300VAC	
NEMKO	EN 60384-14:2013;A1	X1	400VAC or 440VAC	P18222947
		Y2	250VAC or 300VAC	
ENEC (Demko)	EN 60384-14:2013/ A1:2016, EN 60384-14:2013	X1	400VAC or 440VAC	ENEC-01962-A1
		Y2	250VAC or 300VAC	
Demko	EN 60384-14:2013/ A1:2016, EN 60384-14:2013	X1	400VAC or 440VAC	D-07617
		Y2	250VAC or 300VAC	
CQC	GB/T6346.14-2015	X1:400VAC /Y2:250VAC		CQC08001026519
	IEC60384-14:2013	X1: 440VAC /Y2:300VAC		CQC15001121984
KTL	KC60384-1(2015-09) ; KC60384-14(2015-09)	X1	400VAC	SU03065-14004A
		X1	440VAC	SU03065-14001A
		Y2	250VAC	SU03065-14002A
	IEC 60384-14(ed.3)	Y2	300VAC	SU03065-14003A

CERAMIC DISC CAPACITOR SAFETY RECOGNIZED, AC SERIES(pitch5mm)- Small Size	POE-D22-01-E-07	Ver:07	Page:10 / 20
--	-----------------	--------	--------------

7. Specification and test method:

7.1 Operating Temperature Range :

-40 to +125°C

7.2 Test condition:

Test and measurement shall be made at the standard condition. (temperature 15~35°C, relative humidity 45~75% and atmospheric pressure 860~1060hpa). Unless otherwise specified herein.

If doubt occurred on the value of measurement, and measurement was requested by customer capacitors shall be measured at the reference condition. (temperature 20±2°C or 25 ± 2°C, relative humidity 60~70% and atmospheric pressure 860~1060hpa.)

7.3 Performance:

Item		Specification	Testing Method												
1	Appearance and dimensions	No marked defect on appearance form and dimensions. Please refer to [Part number list].	The capacitor should be inspected by naked eyes for visible evidence of defect. Dimensions should be measured with slide calipers.												
2	Marking	To be easily legible.	The capacitor should be inspected by naked eyes.												
3	Dielectric Strength	Between lead wires	No failure. The capacitor should not be damaged when AC2000V(r.m.s.) <50/60Hz> is applied between the lead wires for 60 s. (Charge/Discharge current ≤50mA.)												
		Body Insulation	No failure. First the terminal of capacitor shall be connected together. Then a metal foil shall be closely wrapped around the body of the capacitor distance of about 3 to 6 mm from each terminal. Then the capacitor shall be inserted into a container filled with metal balls of about 1 mm diameter. Finally, AC2000V(rms.) is applied for 60 sec. between the capacitor lead wires and metal balls. (Charge/Discharge current ≤50mA.)												
4	Insulation Resistance(I.R.)	10000MΩ min.	The insulation resistance should be measured with DC500±50V within 60±5 s of charging. The voltage should be applied to the capacitor through a resistor of 1MΩ												
5	Capacitance	Within specified tolerance	Y5P&Y5U&Y5V: The capacitance shall be measured at 20±2°C with 1kHz±20% and 1.0Vrms. SL: The capacitance shall be measured at 25°C with 1MHz±20% and 1.0Vrms												
6	Dissipation Factor(D.F.) Q	Char.	Specifications												
		B(Y5P) E(Y5U)	2.5% max.												
		SL	Q ≥ 400+20C*(C<30pF) Q ≥ 1000 (C ≥ 30pF)												
7	Temperature Characteristic	Char.	Capacitance Change												
		B(Y5P)	Within ± 10%												
		E(Y5U)	Within +20/-55%												
		(Temp. range: -25 to +85°C)													
		Char.	Capacitance Change												
		SL	-1000~+350 ppm/°C												
		(Temp. range: +20 to +85°C)													
			The capacitance measurement shall be made at each step specified in table <table border="1"> <thead> <tr> <th>Step</th> <th>1</th> <th>2</th> <th>3</th> <th>4</th> <th>5</th> </tr> </thead> <tbody> <tr> <td>Temp.(°C)</td> <td>+20±2</td> <td>-25±2</td> <td>+20±2</td> <td>+85±2</td> <td>+20±2</td> </tr> </tbody> </table> Pr-treatment : Capacitor shall be stored at 125±2°C for 1 hour. Then placed at room condition*2 for 24±2 hours before measurement	Step	1	2	3	4	5	Temp.(°C)	+20±2	-25±2	+20±2	+85±2	+20±2
Step	1	2	3	4	5										
Temp.(°C)	+20±2	-25±2	+20±2	+85±2	+20±2										

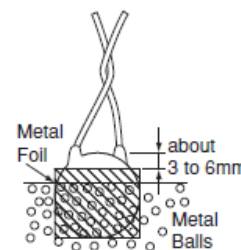

※ "C" expresses nominal capacitance value (pF).

※ "room condition" temperature : 15~35°C, humidity : 45~75%, atmospheric pressure : 86~106kPa

CERAMIC DISC CAPACITOR SAFETY RECOGNIZED, AC SERIES(pitch5mm)- Small Size

POE-D22-01-E-07

Ver:07

Page:11 / 20

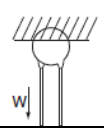
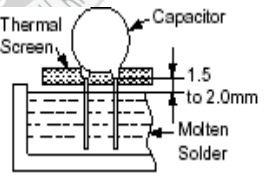
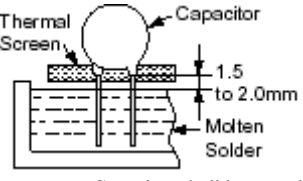
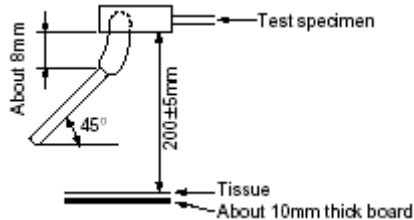
No	Item	Specification	Testing Method
8	Robustness of terminations	Tensile	Lead wire shall not cut off capacitor shall not be broken. As shown in the figure at right, fix the body of the capacitor and apply a tensile weight gradually to each lead wire in the radial direction of the capacitor up to 10N and keep it for 10±1 sec. 
		Bending	Lead wire shall not cut off capacitor shall not be broken. With the termination in its normal position, the specimen is held by its body in such a manner that the axis of the termination is vertical; a mass applying a force of 5N is then suspended from the end of the termination. The body of the specimen is then inclined, within a period of 2 to 3sec, through an angle of approximately 90° in the vertical plane and then returned to its initial position over the same period of time; this operation constitutes one bend. One bend immediately followed by a second bend in the opposite direction.
9	Soldering Effect (Non-Preheat)	Appearance	No marked defect
		I.R.	1000MΩ min.
		Dielectric Strength	Per Item 3.
		Capacitance Change	B(Y5P),E(Y5U) : Within ±10% SL : Within±2.5% or ±0.25pF, Whichever is large.
			As shown in figure, the lead wires should be immersed in solder of 350 ± 10 °C or 260 ± 5 °C up to 1.5 to 2.0mm from the root of terminal for 3.5 ± 0.5 sec (10 ± 1 sec for 260± 5 °C)  Pre-treatment: Capacitor shall be stored at 125±2°C for 1hour.then placed at *1room condition for 24±2hours before initial measurements. Post-treatment: Capacitor shall be stored for 1 to 2hours at *1room condition.
10	Soldering Effect (On-Preheat)	Appearance	No marked defect.
		I.R.	1000MΩ min.
		Dielectric Strength	Per Item 3.
		Capacitance Change	B(Y5P),E(Y5U) : Within ±10% SL : Within±2.5% or ±0.25pF, Whichever is large.
			First the capacitor should be stored at 120 + 0 / -5 °C for 60 + 0 / -5sec. Then, as in figure , the lead wires should be immersed solder of 260 + / - 5 °C up to 1.5 to 2.0 mm from the root of terminal for 7.5 +0 / -1 sec.  Pre-treatment: Capacitor shall be stored at 125±2°C for 1hour.then placed at *1room condition for 24±2hours before initial measurements. Post-treatment: Capacitor shall be stored for 1 to 2hours at *1room condition.
11	Solderability of leads	Lead wire should be soldered with uniform coating on the axial direction over 3/4 of the circumferential direction.	The lead wire of capacitor should be dipped into molten solder for 5 ± 0.5 sec. The depth of immersion is up to about 1.5 to 2.0 mm from the root of lead wires. Temp. of solder : Lead free solder (Sn97 -Cu3) 245 ± 5 °C
12	Passive Flammability	The burning time shall not be exceeded the time 30 sec. The tissue paper shall not ignite.	The capacitor under test shall be held in the flame in the position, which best promotes burning. Each specimen shall only be exposed once to the flame. Time of exposure to flame : 30 sec Length of flame : 12±1 mm Gas burner : Length 35 mm min. Inside Dia. : 0.5±0.1 mm Outside Dia. : 0.9 mm max. Gas : Butane gas Purity 95% min. 

※ "room condition" temperature : 15~35°C, humidity : 45~75%,atmospheric pressure : 86~106kPa

※ "C" expresses nominal capacitance value (pF).

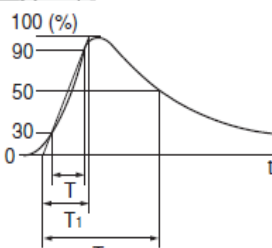
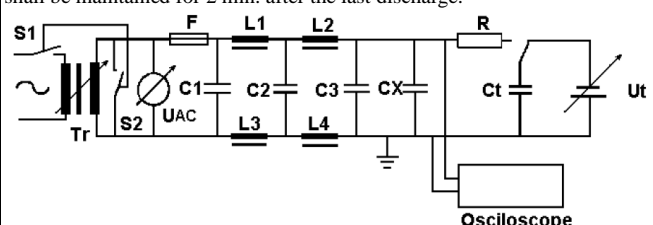
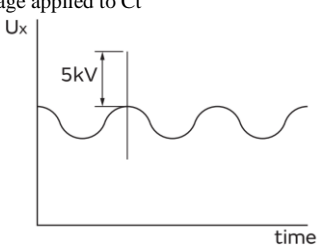
No	Item	Specification	Testing Method
13	Life	<p>Appearance: No marked defect.</p> <p>Capacitance Change: B(Y5P),E(Y5U) : Within $\pm 20\%$ SL : Within $\pm 3\%$ or $\pm 0.3\text{pF}$, Whichever is large.</p> <p>I.R.: B(Y5P),E(Y5U) : $3000\text{M}\Omega$ min. SL : $1000\text{M}\Omega$ min.</p> <p>Dielectric Strength: Per Item 3.</p>	<p>Impulse Voltage:</p> <p>Each individual capacitor shall be subjected to a 5kv impulses for three times. After the capacitors are applied to life test. The waveform will be determined by the test circuit parameters. Details of the test circuit are given in IEC 60384-14 Annex A.</p>  <p>Front time (T_1) = $1.2\mu\text{s} = 1.67T$ Time to half-value (T_2) = $50\mu\text{s}$</p> <p>The specimen capacitors are placed in a circulating air oven for a period of 1000 hrs. The air in the oven is maintained at a temperature of $125\pm 2^\circ\text{C}$. Throughout the test. The capacitors are subjected to an AC425Vrms.(for 0AC type) or AC510Vrms.(for 1AC type) alternating voltage of mains frequency. Pre-treatment: Capacitor shall be stored at $125\pm 2^\circ\text{C}$ for 1hour, then placed at [*]room condition for 24 ± 2hours before initial measurements. Post-treatment: Capacitor shall be stored for 1 to 2hours at [*]room condition.</p>
14	Active Flammability	The cheesecloth shall not be on fire.	<p>The specimens shall be individually wrapped in at least one but more than two complete layers of cheesecloth. The specimens shall be subjected to 20 discharges. The interval between successive discharges shall be 5sec. The Uac shall be maintained for 2 min. after the last discharge.</p>  <p>C1,2 : $1\mu\text{F}\pm 10\%$ C3 : $0.033\mu\text{F}\pm 5\%$ 10KV L1-4 : $1.5\text{mH}\pm 20\%$ 16A Rod core choke R : $100\Omega\pm 2\%$ Ct : $3\mu\text{F}\pm 5\%$ 10KV Uac : $U_r\pm 5\%$ U_r : Rated working voltage Cx : Capacitor F : Fuse, Rated 10A U_t : Voltage applied to Ct</p> 

※ "room condition" temperature : $15\sim 35^\circ\text{C}$, humidity : $45\sim 75\%$, atmospheric pressure : $86\sim 106\text{kPa}$
 ※ "C" expresses nominal capacitance value (pF).

No	Item	Specification	Testing Method															
15	Humidity (Under Steady State)	Appearance	No marked defect															
		Capacitance Change	B(Y5P) : Within ±10% E(Y5U) : Within ±20% SL : Within±2.5% or ±0.25pF, Whichever is large.															
		D.F. Q	<table border="1" style="width:100%; border-collapse: collapse;"> <tr> <th style="width:10%;">Char.</th> <th style="width:90%;">Specifications</th> </tr> <tr> <td>B(Y5P)</td> <td>5.0% max.</td> </tr> <tr> <td>E(Y5U)</td> <td>Q ≥ 100+10×C/3^{**2}(C<30pF)</td> </tr> <tr> <td>SL</td> <td>Q ≥ 200 (C ≥ 30pF)</td> </tr> </table>	Char.	Specifications	B(Y5P)	5.0% max.	E(Y5U)	Q ≥ 100+10×C/3 ^{**2} (C<30pF)	SL	Q ≥ 200 (C ≥ 30pF)							
		Char.	Specifications															
		B(Y5P)	5.0% max.															
E(Y5U)	Q ≥ 100+10×C/3 ^{**2} (C<30pF)																	
SL	Q ≥ 200 (C ≥ 30pF)																	
I.R.	B(Y5P),E(Y5U) : 3000MΩ min. SL : 1000MΩ min.																	
Dielectric strength	Per Item 3																	
			Set the capacitor for 500±12 hours at 40±2℃, in 90 to 95% humidity. Pre-treatment: Capacitor shall be stored at 125±2℃ for 1hour.then placed at *1room condition for 24±2hours before initial measurements. Post-treatment: Capacitor shall be stored for 1 to 2hours at *1room condition.															
16	Humidity Loading	Appearance	No marked defect															
		Capacitance Change	B(Y5P) : Within ±10% E(Y5U) : Within ±20% SL : Within±2.5% or ±0.25pF, Whichever is large.															
		D.F. Q	<table border="1" style="width:100%; border-collapse: collapse;"> <tr> <th style="width:10%;">Char.</th> <th style="width:90%;">Specifications</th> </tr> <tr> <td>B(Y5P)</td> <td>5.0% max.</td> </tr> <tr> <td>E(Y5U)</td> <td>Q ≥ 100+10×C/3^{**2}(C<30pF)</td> </tr> <tr> <td>SL</td> <td>Q ≥ 200 (C ≥ 30pF)</td> </tr> </table>	Char.	Specifications	B(Y5P)	5.0% max.	E(Y5U)	Q ≥ 100+10×C/3 ^{**2} (C<30pF)	SL	Q ≥ 200 (C ≥ 30pF)							
		Char.	Specifications															
		B(Y5P)	5.0% max.															
E(Y5U)	Q ≥ 100+10×C/3 ^{**2} (C<30pF)																	
SL	Q ≥ 200 (C ≥ 30pF)																	
I.R.	B(Y5P),E(Y5U) : 3000MΩ min. SL : 1000MΩ min.																	
Dielectric strength	Per Item 3																	
			Apply the rated voltage for 500±12 hours at 40±2℃, in 90 to 95% humidity. Pre-treatment: Capacitor shall be stored at 125±2℃ for 1hour.then placed at *1room condition for 24±2hours before initial measurements. Post-treatment: Capacitor shall be stored for 1 to 2hours at *1room condition.															
17	Temperature Cycle	Appearance	No marked defect															
		Capacitance Change	<table border="1" style="width:100%; border-collapse: collapse;"> <tr> <th style="width:10%;">Char.</th> <th style="width:90%;">Capacitance Change</th> </tr> <tr> <td>B(Y5P)</td> <td>Within ± 10%</td> </tr> <tr> <td>E(Y5U)</td> <td>Within ± 20%</td> </tr> <tr> <td>SL</td> <td>Within ± 10%</td> </tr> </table>	Char.	Capacitance Change	B(Y5P)	Within ± 10%	E(Y5U)	Within ± 20%	SL	Within ± 10%							
		Char.	Capacitance Change															
		B(Y5P)	Within ± 10%															
		E(Y5U)	Within ± 20%															
SL	Within ± 10%																	
D.F. Q	<table border="1" style="width:100%; border-collapse: collapse;"> <tr> <th style="width:10%;">Char.</th> <th style="width:90%;">Specifications</th> </tr> <tr> <td>B(Y5P)</td> <td>5.0% max.</td> </tr> <tr> <td>E(Y5U)</td> <td>7.5% max.</td> </tr> <tr> <td>SL</td> <td>Q ≥ 275+5/2C^{**2} (C<30pF) Q ≥ 350 (C ≥ 30pF)</td> </tr> </table>	Char.	Specifications	B(Y5P)	5.0% max.	E(Y5U)	7.5% max.	SL	Q ≥ 275+5/2C ^{**2} (C<30pF) Q ≥ 350 (C ≥ 30pF)									
Char.	Specifications																	
B(Y5P)	5.0% max.																	
E(Y5U)	7.5% max.																	
SL	Q ≥ 275+5/2C ^{**2} (C<30pF) Q ≥ 350 (C ≥ 30pF)																	
I.R.	3000MΩ min.																	
Dielectric strength	Per Item 3																	
			The capacitor should be subjected to 100 temperature cycles, <Temperature Cycle time: 100 cycles> <table border="1" style="width:100%; border-collapse: collapse; margin-top: 5px;"> <thead> <tr> <th style="width:10%;">Step</th> <th style="width:60%;">Temperature(℃)</th> <th style="width:30%;">Time(min)</th> </tr> </thead> <tbody> <tr> <td>1</td> <td>-40+0/-3</td> <td>30</td> </tr> <tr> <td>2</td> <td>Room temp.</td> <td>3</td> </tr> <tr> <td>3</td> <td>125+3/-0</td> <td>30</td> </tr> <tr> <td>4</td> <td>Room temp.</td> <td>3</td> </tr> </tbody> </table> Pre-treatment: Capacitor shall be stored at 125±2℃ for 1hour.then placed at *1room condition for 24±2hours. Post-treatment: Capacitor shall be stored for 1 to 2hours at *1room condition.	Step	Temperature(℃)	Time(min)	1	-40+0/-3	30	2	Room temp.	3	3	125+3/-0	30	4	Room temp.	3
Step	Temperature(℃)	Time(min)																
1	-40+0/-3	30																
2	Room temp.	3																
3	125+3/-0	30																
4	Room temp.	3																

※ "room condition" temperature : 15~35℃, humidity : 45~75%,atmospheric pressure : 86~106kPa
 ※ "C" expresses nominal capacitance value (pF).

8.Packing Baggage :

8.1 Packing size:

Type	Box	Carton
Bulk	<p>Unit:mm</p>	<p>Unit:mm</p> <p>P.O.# C/NO. PF% WV N.W.: KG KPCS G.W.: KG</p>
Ammo taping	<p>Unit:mm</p>	<p>Unit:mm</p> <p>P.O.# C/NO. PF% WV N.W.: KG KPCS G.W.: KG</p>

8.2 Packing quantity:

Packing type	The code of 14th to15th in SAP P/N	MPQ (Kpcs/Box)
Taping	AN	1
	AM	1

Packing type	Lead length	The code of 14th to15th in SAP P/N	MPQ	
			Kpcs / Bag	Kpcs / Box
Bulk	Long lead (L ≥ 20mm)	05~11	0.5	1.5
	Short lead (L < 20mm)	05~11	0.5	2

8.3 Label samples:

CUST P/N:
 NEW POE P/N: YV0AC222M060BAFD7B QTY:1000 PCS
 POE P/N: YV0AC222M060BAFD7B
 CAP:2200pF TOL: + -20%
 VOLT:X1:400VAC, Y2:250VAC T.C: Y5V
 LOT NO.: 741HB01087 DATE:2018.04.02
 PAN OVERSEAS(GUANGZHOU) ELECTRONIC CO.,LTD.
 R001

UL60384-14
IEC60384-14
40/125/21/C

CERAMIC DISC CAPACITOR SAFETY RECOGNIZED, AC SERIES(pitch5mm)- Small Size	POE-D22-01-E-07	Ver:07	Page:15 / 20
--	-----------------	--------	--------------

9. Caution:

9.1 Operating voltage

When DC-rated capacitors are to be used in AC or ripple current circuits, be sure to maintain the V_{p-p} value of the applied voltage or the V_{0-p} which contains DC bias within the rated voltage range.

When the voltage is started to apply to the circuit or it is stopped applying, the irregular voltage may be generated for a transit period because of resonance or switching. Be sure to use a capacitor within rated voltage containing these irregular voltage.

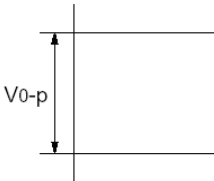
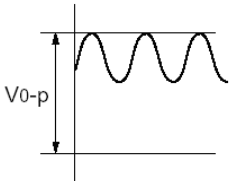
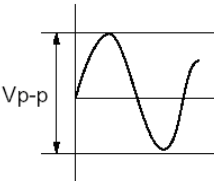
Voltage	DC Voltage	DC+AC Voltage	AC Voltage
Positional measurement			

9.2 Operating temperature and self-generated heat

Keep the surface temperature of a capacitor below the upper limit of its rated operating temperature range. Be sure to take into account the heat generated by the capacitor itself.

9.3 Test condition for withstanding voltage

(1) Test equipment

Test equipment for AC withstanding voltage should be used with the performance of the wave similar to 50/60 Hz sine wave.

If the distorted sine wave or over load exceeding the specified voltage value is applied, the defective may be caused.

(2) Voltage applied method

When the withstanding voltage is applied, capacitor's lead or terminal should be firmly connected to the out-put of the withstanding voltage test equipment, and then the voltage should be raised from near zero to the test voltage.

If the test voltage without the raise from near zero voltage would be applied directly to capacitor, test voltage should be applied with the *zero cross. At the end of the test time, the test voltage should be reduced to near zero, and then capacitor's lead or terminal should be taken off the out-put of the withstanding voltage test equipment.

If the test voltage without the raise from near zero voltage would be applied directly capacitor, the surge voltage may arise, and therefore, the defective may be caused.

*ZERO CROSS is the point where voltage sine wave pass 0V.

- See the right figure -

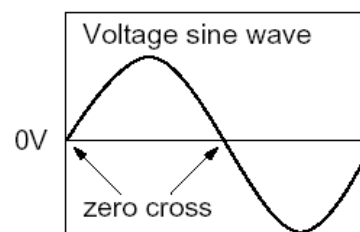

to

(3) Applied voltage

The voltages of Table shall be applied between the respective measuring points of 1 min for qualification approval and periodic testing and for a period of not less than 1 s for lot-by-lot quality conformance testing, a voltage proof test such as Test C shall be carried out only for qualification approval tests and periodic tests;

Attention is drawn to the fact that repetition of the voltage proof test by the user may damage the capacitor. If repetition of the voltage proof test is made by the user, the applied voltage should not be greater than 66 % of the test voltage specified in Table .

CERAMIC DISC CAPACITOR SAFETY RECOGNIZED, AC SERIES(pitch5mm)- Small Size	POE-D22-01-E-07	Ver:07	Page:16 / 20
--	-----------------	--------	--------------

Table –Voltage proof

Class	Range of rated voltages	Test A	Test B or Test C
X1	$\leq 1\,000\text{ V}$	$4,3\text{ UR (d.c.) c}$	$2\text{ UR} + 1\,500\text{ V (a.c.)}$ with a minimum of $2\,000\text{ V (a.c.) a}$
Y2	$\geq 150\text{ V}$ $\leq 500\text{ V}$	$\text{UR} + 1\,200\text{ V (a.c.)}$ with a minimum of $1\,500\text{ V (a.c.) b}$	$2\text{ UR} + 1\,500\text{ V (a.c.)}$ with a minimum of $2\,000\text{ V (a.c.) b}$

^a For Delta and T-connected capacitor units according to Figures 5b and 5c, the test voltage for terminals to case shall be the appropriate test voltage for the Y-capacitors.

^b For lot-by-lot tests of Class Y2 capacitors, the a.c. test voltage may be replaced by a d.c. voltage of 1,5 times the prescribed a.c. voltage.

^c The UR in this d.c. test is the rated a.c.voltage value.

Note:

Test A – Between terminations

Test B – Internal insulation

Test C – External insulation (applicable only to insulated capacitors in nonmetallic case or in insulated metal case)

Figure 5b – Delta by-pass capacitor (in metallic housing)

Figure 5c – Example of a T-connected by-pass capacitor (in non-metallic housing)

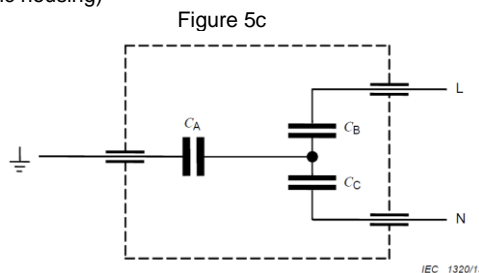
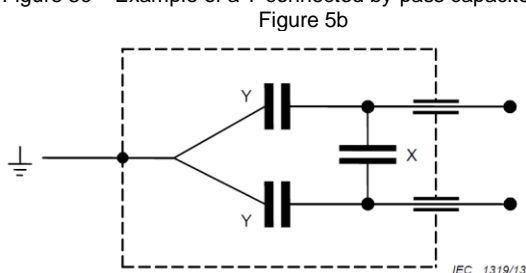

*For capacitors with non-metallic housings, the earth connection is brought out as a separate termination as is shown in Figure 5c.

9.4 Fail-Safe

When capacitor would be broken, failure may result in a short circuit. Be sure to provide an appropriate fail-safe function like a fuse on your product if failure would follow an electric shock, fire or fume.

9.5 Vibration and impact

Do not expose a capacitor or its leads to excessive shock or vibration during use.

9.6 Soldering

When soldering this product to a PCB/PWB, do not exceed the solder heat resistance specification of the capacitor. Subjecting this product to excessive heating could melt the internal junction solder and may result in thermal shocks that can crack the ceramic element.

When soldering capacitor with a soldering iron, it should be performed in following conditions.

Temperature of iron-tip : 400°C max.

Soldering iron wattage : 50W max.

Soldering time : 3.5s max.

9.7 Bonding, resin molding and coating

In case of bonding, molding or coating this product, verify that these processes do not affect the quality of capacitor by testing the performance of the bonded, molded or coated product in the intended equipment.

In case of the amount of applications, dryness / hardening conditions of adhesives and molding resins containing organic solvents (ethyl acetate, methyl ethyl ketone, toluene, etc.) are unsuitable, the outer coating resin of a capacitor is damaged by the organic solvents and it may result, worst case, in a short circuit.

The variation in thickness of adhesive, molding resin or coating may cause a outer coating resin cracking and/or ceramic element cracking of a capacitor in a temperature cycling.

9.8 Treatment after bonding, resin molding and coating

When the outer coating is hot (over 100 °C) after soldering, it becomes soft and fragile.

So please be careful not to give it mechanical stress.

Failure to follow the above cautions may result, worst case, in a short circuit and cause fuming or partial dispersion when the product is used.

9.9 Operating and storage environment

The insulating coating of capacitors does not form a perfect seal; therefore, do not use or store capacitors in a corrosive atmosphere, especially where chloride gas, sulfide gas, acid, alkali, salt or the like are present. And avoid exposure to moisture. Before cleaning, bonding, or molding this product, verify that these processes do not affect product quality by testing the performance of a cleaned, bonded or molded product in the intended equipment. Store the capacitors where the temperature and relative humidity do not exceed -10 to 40°C and 15 to 85%.

Use capacitors within 6 months after delivered. Check the solderability after 6 months or more.

9.10 Limitation of applications

Please contact us before using our products for the applications listed below which require especially high reliability for the prevention of defects which might directly cause damage to the third party's life, body or property.

1. Aircraft equipment
2. Aerospace equipment
3. Undersea equipment
4. Power plant control equipment
5. Medical equipment
6. Transportation equipment (vehicles, trains, ships, etc.)
7. Traffic signal equipment
8. Disaster prevention / crime prevention equipment
9. Data-processing equipment exerting influence on public
10. Application of similar complexity and/or reliability requirements to the applications listed in the above.

10. Notices:

10.1 Cleaning (ultrasonic cleaning):

To perform ultrasonic cleaning, observe the following conditions.

Rinse bath capacity : Output of 20 watts per liter or less.

Rinsing time : 5 min maximum.

Do not vibrate the PCB/PWB directly.

Excessive ultrasonic cleaning may lead to fatigue destruction of the lead wires.

CERAMIC DISC CAPACITOR SAFETY RECOGNIZED, AC SERIES(pitch5mm)- Small Size	POE-D22-01-E-07	Ver:07	Page:18 / 20
--	-----------------	--------	--------------

10.2 List of substances that affect the insulation strength of coating:

Epoxy resin solvent

Category	Model		
Ketone	Acetone	Butanone	Cyclohexanone
Esters	Ethyl acetate	Dibutyl phthalate	
Chlorinated hydrocarbons	Dichloromethane		

Epoxy resin thinner

Category		Model
Reactive diluent/activated thinner	Simple function group	HK-66 (Alkyl glycidyl ether)
		501 (Butyl glycidyl ether)
		690 (Phenyl Glycidyl Ether)
		AGE (C12-14Aliphatic Polyalcohol Glycidyl Ether)
		692 (Benzyl Glycidyl Ether)
	Two functional groups	D-678 (Neopentyl glycol diglycidyl ether)
		622 (1,4-Butanediol diglycidyl ether)
		669 (Ethylene glycol diglycidyl ether)
		X-632 (Polypropylene glycol diglycidyl ether)
		X-652 (1,6-Hexadiol diglycidyl ether)
Non-activated thinner	D-691Epoxypropane o-methylphenyl ether	
	Anhydrous ethanol	Toluene
	Ethyl acetate	Dimethylbenzene
	Dimethyl formamide	Butyl acetate
	Acetone	Styrene
	Polyol	Benzyl alcohol

Note: The above substances should not contact the coating of the product body, otherwise it will affect the insulation strength of the product

10.3 Capacitance change of capacitors

Class 1 capacitors

Capacitance might change a little depending on a surrounding temperature or an applied voltage.

Please contact us if you use for the strict time constant circuit.

Class 2 and 3 capacitors

Class 2 and 3 capacitors like temperature characteristic B, E and F have an aging characteristic, whereby the capacitor continually decreases its capacitance slightly if the capacitor leaves for a long time. Moreover, capacitance might change greatly depending on a surrounding temperature or an applied voltage. So, it is not likely to be able to use for the time constant circuit.

Please contact us if you need a detail information.

10.4 Performance check by equipment

Before using a capacitor, check that there is no problem in the equipment's performance and the specifications.

Generally speaking, CLASS 2 ceramic capacitors have voltage dependence characteristics and temperature dependence characteristics in capacitance. So, the capacitance value may change depending on the operating condition in a equipment. Therefore, be sure to confirm the apparatus performance of receiving influence in a capacitance value change of a capacitor, such as leakage current and noise suppression characteristic.

Moreover, check the surge-proof ability of a capacitor in the equipment, if needed, because the surge voltage may exceed specific value by the inductance of the circuit.

11. Note

11.1 Please make sure that your product has been evaluated in view of your specifications with our product being mounted to your product.

11.2 You are requested not to use our product deviating from this specification.

11.3 Do not use these products in any Automotive Power train or Safety equipment including Battery charger for Electric Vehicles and Plug-in Hybrid.

12. Soldering Recommendation:

12.1 Wave Soldering Profile:

- Temperature conditions of the flow is recommended as shown in the chart
- Must implement the pre-heat
- Maximum peak flow temperature is recommended 265°C
- Time “T” implement in the chart recommended within 20 sec. it temperature exceed 200°C
- Take care with the flow solder not to touch the capacitor body directly at mounting

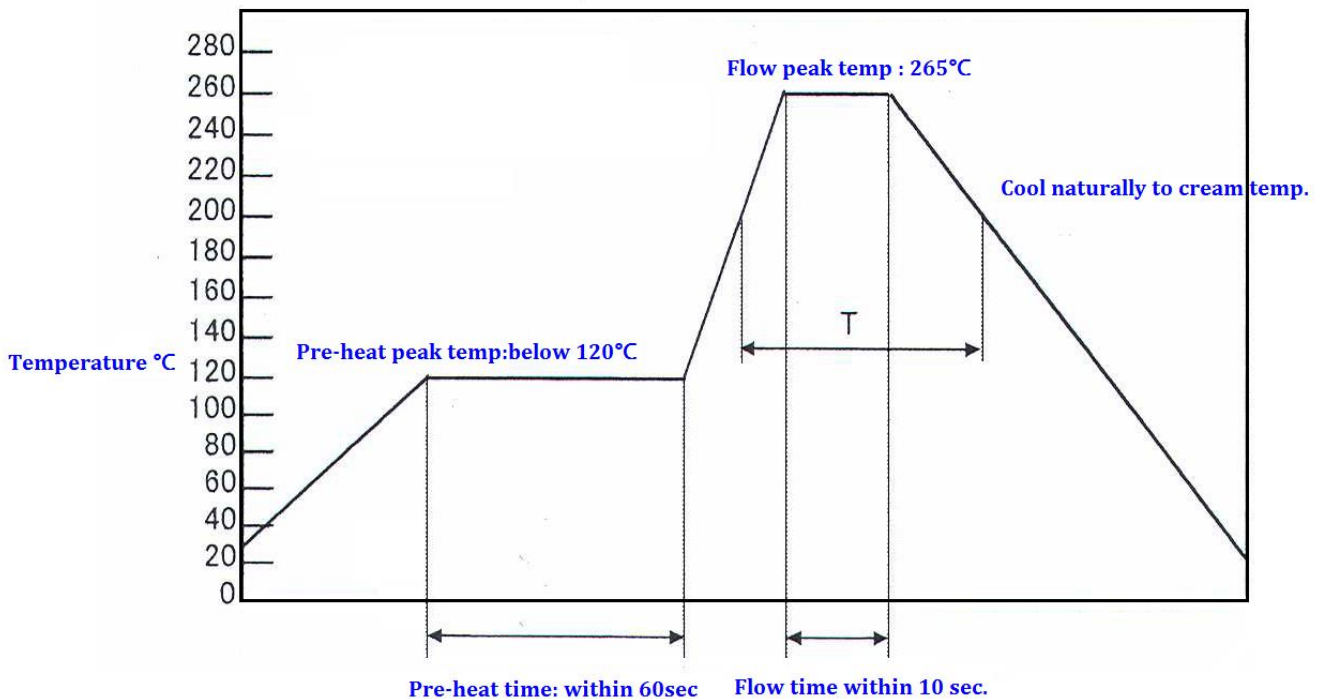

Chart to show flow recommended temp

12.2 Recommended Reworking Conditions with Soldering Iron :

- Temperature of iron-tip: 400 degrees C. max.
- Soldering iron wattage: 50W max.
- Soldering time: 3.5 sec. max.
- Distance from coating body: 2 mm (min.)

12.3 Reflow-Soldering : Lead Ceramic Cap. should not be soldered by reflow-soldering.

13. Drawing of internal structure and material list :

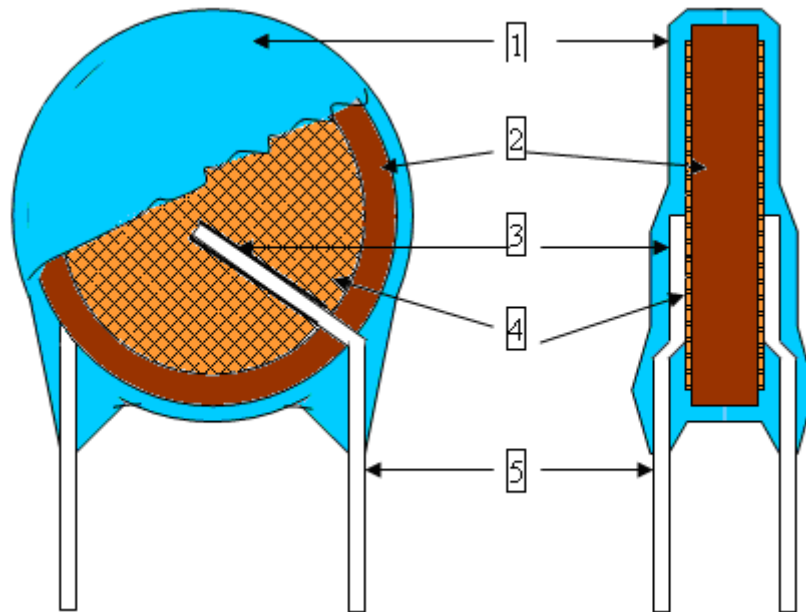

Remarks :

No.	Part name	Material	Model/Type	Component
1	Insulation Coating	Epoxy polymer	1.EF-150 2.ECP-357 3. PCE-300	Pyromellitic dianhydride15 · Silica20 · Resins (Epoxy)65 (Blue / UL 94 V-0)
2	Dielectric Element	Ceramic	SL/Y5P/Y5U	SL: SrCO ₃ /TiO ₂ /Bi ₂ O ₃ /CaCO ₃ Y5P: BaTiO ₃ /Bi ₂ O ₃ /SnO ₂ /CeO ₂ Y5U: BaTiO ₃ /ZrO ₂ / CaCO ₃
3	Solder	Tin-silver	Sn97 -Cu3	Sn97 -Cu3
4	Electrodes	Cu	Confidentiality	Confidentiality
5	Leads wire	Tinned copper clad steel wire	0.55 +0.1/-0.05mm	Sn2.5 [Surface plating: Sn 100%(3~7μm)] · Cu5 & Fe92.5 [Substrate metal]

*Constituent structure chart of lead

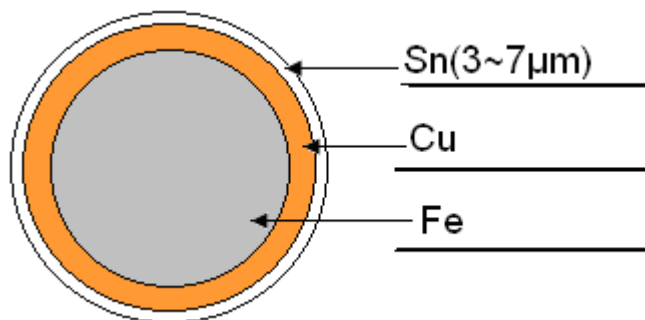

单击下面可查看定价，库存，交付和生命周期等信息

[>>Walsin Technology\(华新科技\)](#)